

## Slim Line Series **Condenser CM-2**

Field experience led to our innovative CM-2 condenser design for commercial and school bus air conditioning. Lower condensing temperatures and pressures result in enhanced cooling, longer compressor life and more efficient system operation. In this MCC unique design, air is channeled away from the vehicle undercarriage, eliminating recircu-

lation of hot air. Need high performance in new or retrofit applications, specify the MCC CM-2 condenser. The CM-2 condenser can be matched with other MCC components to provide a complete air conditioning system that meets your exact vehicle size, operating mode and environment.



### Features

- Slim Line CM-2 cabinet is constructed using rugged, powder coated, steel construction
- Zinc coated for added durability and corrosion protection.
- Integrated high pressure safety switch as standard equipment
- Unitized motor/fan package increases service access and decreases service time
- Winter protection package
- Skirt mount or component mount air inlet grill
- 12V or 24V operation
- Stackable kit available
- Plug-n-Play connectors on unit and fan motor provide for ease of installation and motor service
- Incorporated single piece receiver/dryer and system moisture indicator reduced possible leak joints

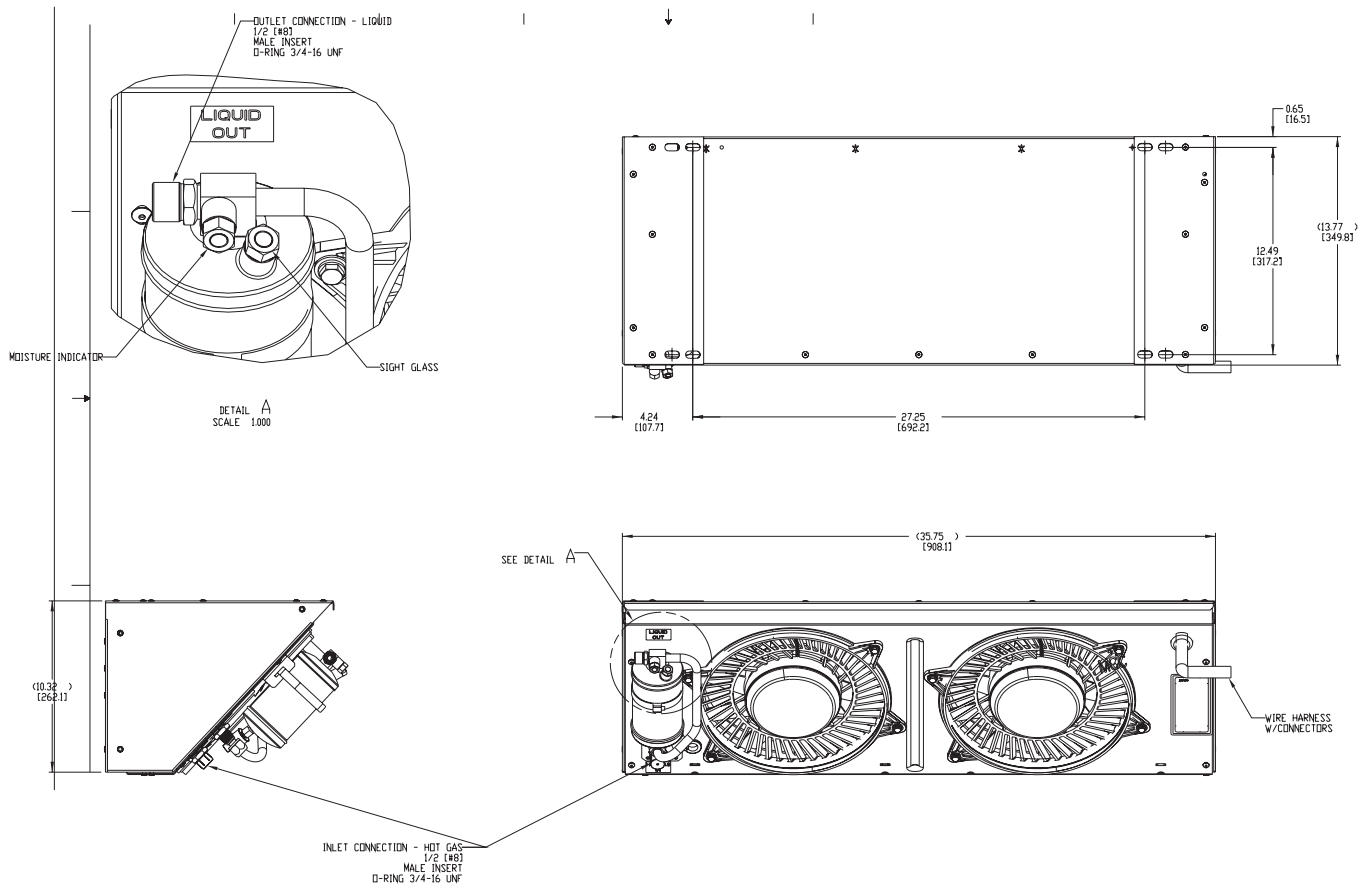

## Technical Data

Capacity	60000 Btu/hr (17.58 kW) IMACA <sup>[1]</sup>
Air flow	900 CFM (1529 m <sup>3</sup> /hr)
Condenser coil	Advanced technology Micro Channel Heat Exchanger (MCHX)
Condenser fans	Unitized, low-profile, axial-flow type propeller fans balanced for quiet, vibration-free operation with finger guard
Fan motors	Totally enclosed, pancake-style, permanent-magnet type with extended-life, permanently lubricated bearings
Max amperage requirement	14 amps @ 13.5 VDC; 7 amps @ 27.0 VDC
Safety controls	High refrigerant pressure cut-out 400 psi (28 bar); cut-in 300 psi (21 bar)
Receiver filter dryer	16 in <sup>3</sup> (262 cm <sup>3</sup> ), 1/2" [#8] Male Insert O-Ring (MIOR)
Weight	45 lbs (20.5 kg)
Available color	Midnight black

[1] IMACA conditions: 100°F (38°C) / 90°F (32°C) / 50% RH