

Roof Mount Unit **Eco 353**

Inline roof mount Air-conditioning, ventilation and heating system

The Eco 353 inline rooftop bus air-conditioning system has been enhanced to meet the demanding and varied needs of the Global market. The lightweight, high capacity heavy duty transit bus rooftop air conditioning system offers improved overall fuel consumption, enhanced reliability, reduced life cycle, service costs compared to its predecessors.

When combined with MCC's industry leading O5G compressor, the Eco 353 also offers optimum cooling capacity.

There are four versions with capacities covering all climate zones and a wide variety of options to meet customer requirements and expectations.

The system uses MCC's micro-channel heat exchanger (MCHX) coil technology, which delivers significant performance improvements through better heat transfer and thermal performance. Extended motor life is available through the use of brushless motors.



Eco 353 Narrow

Features

- Optimum performance for a wide range of cooling requirements
- Microchannel Heat Exchanger Coil technology for improved reliability, corrosion resistance and reduced refrigerant charge
- Up to 20% shorter and 16% lighter than previous models
- Fully accessible for easy installation and maintenance from inside the bus
- One basic platform with 3 major capacities

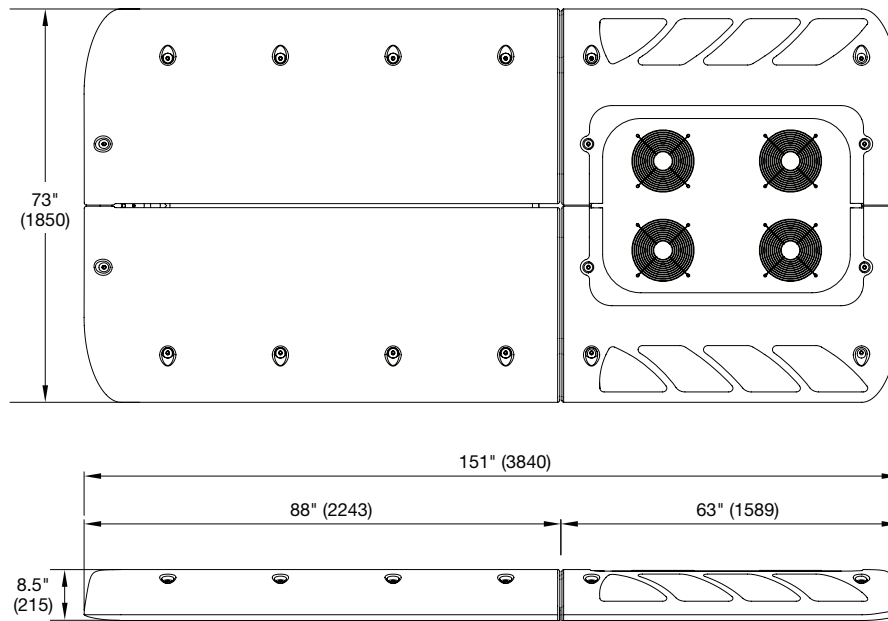

Eco 353 Standard

Technical Data

	Eco 353 - V24	Eco 353 - V28	Eco 353 - V32
Cooling capacity @ max ^[1]	109000 Btu/hr (32 kW)	130000 Btu/hr (38 kW)	143000 Btu/hr (42 kW)
Cooling capacity @ ARI ^[2]	82000 Btu/hr (24 kW)	96000 Btu/hr (28 kW)	109000 Btu/hr (32 kW)
Heating @ 7 gpm (100F Δ T)	130000 Btu/hr (38 kW)	130000 Btu/hr (38 kW)	82000 Btu/hr (24 kW)
Length	151" (3840 mm)	151" (3840 mm)	151" (3840 mm)
Width Standard	73" (1850 mm)	73" (1850 mm)	73" (1850 mm)
Width Narrow	58" (1490 mm)	58" (1490 mm)	58" (1490 mm)
Height	8.5" (215 mm)	8.5" (215 mm)	8.5" (215 mm)
Weight	385 lbs (175 kg)	420 lbs (190 kg)	450 lbs (204 kg)
Refrigerant	R134a	R134a	R134a
Airflow (Max)	3900 CFM (6600 m ³ /hr)	3900 CFM (6600 m ³ /hr)	5200 CFM (8800 m ³ /hr)
Current Draw (Max)	95 A	95 A	128 A

[1] Max conditions 95°F (35°C)/104°F (40°C)/50% RH

[2] ARI conditions: 95°F (35°C) / 80°F (27°C) / 50% RH