

PROAIR™

CLIMATE COMFORT IN MOTION

BUS AIR CONDITIONING CR-2 CONDENSER

The PROAIR CR-2 condenser is designed for roof mount applications. We have manufactured this product to offer our customers greater flexibility in condenser placement.

It's low profile design, high performance, serviceability and installation ease are the result of many years of experience in the transportation industry.

ADVANCED FEATURES

- Low Profile Aerodynamic Design
- Heavy Duty, Durable TPO Cover
- Lightweight, Rust-Proof Aluminum Powder Coated Frame
- Internally Enhanced Copper Tubing
- Unequalled Heat Rejection....
 - Lower Cooling Temperatures
 - Lower Head Pressures
- 12 Inch Diameter Fan for Increased Airflow
- Sealed Motor Design
- Sealed Electrical Connections

OPTIONS

- Optional Mounting Rails for Curved or Flat Roofs
- 12 Volt or 24 Volt Motors
- Branch Guard

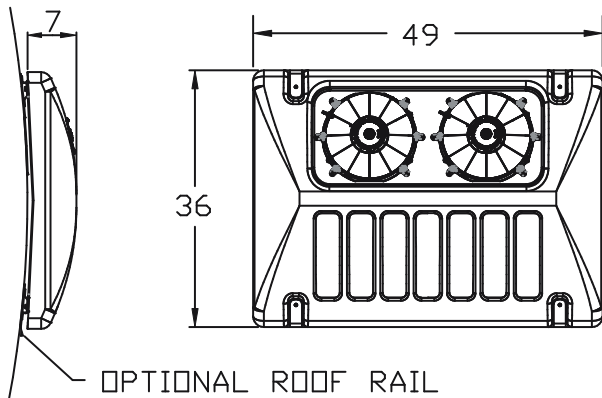

SPECIFICATIONS

RATING: Up to 70,000 Btu/Hr IMACA
(34,000 Btu/Hr ARI)

AIRFLOW: 2460 cfm

AMPERAGE DRAW: 23 Amps @ 13.5 Volts
11 Amps @ 26 Volts

CONDENSER FANS: 12 Inch Diameter Sealed Motors.

FILTER DRIER/SIGHTGLASS: 16 Cu. Inch Displacement w/ Moisture Indicator

WEIGHT: 43 lbs.

Specifications subject to change without notice.

PROAIR™

CLIMATE COMFORT IN MOTION

715 Willow Springs Lane
York, PA 17406
717 / 767-2775
Toll Free: 877 / 228-4247
Fax: 717 / 767-3658

★ 3 YEAR ★
LIMITED WARRANTY

WWW.PROAIRLLC.COM

WWW.ACTUSA.US.COM

RELY ON OUR EXPERIENCE TO PROPERLY APPLY YOUR BUS AIR CONDITIONING SYSTEM

Form#CR2 rev12/18

Copyright 2018

Printed in the USA