

PROAIR™

CLIMATE COMFORT IN MOTION

BUS AIR CONDITIONING

CR-3

ROOF MOUNTED CONDENSER

ADVANCED FEATURES

- Light Weight Rugged Aluminum Frame
- Attractive Durable TPO Cover
- Integral Filter Drier
- O-Ring Connections for Maximum Leak Protection
- Unequalled Heat Rejection Yields
 - Lower Discharge Pressure
 - Longer Compressor Life
- Three Sealed High Capacity 12" Fans
- Enhanced Copper Tube Aluminum Coils
- Single Circuit Design

OPTIONS

- 12 Volt or 24 Volt Motors
- Branch Guard



SPECIFICATIONS

RATING: Up to 95,000 Btu/Hr IMACA
(48,000 Btu/Hr ARI)

AIRFLOW: 3960 cfm

AMPERAGE DRAW: 34 Amps @ 13.5 Volts
17 Amps @ 26 Volts

CONDENSER FANS: Three 12 Inch Diameter
Sealed Motors.

WEIGHT: 68.5 lbs.

Specifications subject to change without notice.

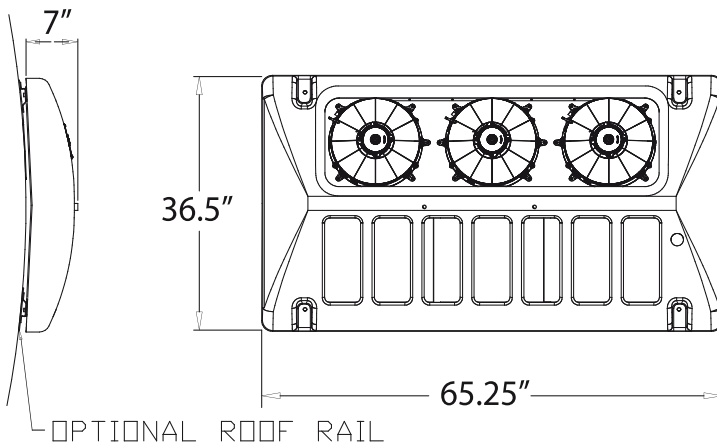

PROAIR™

CLIMATE COMFORT IN MOTION

715 Willow Springs Lane
York, PA 17406
717 / 767-2775
Toll Free: 877 / 228-4247
Fax: 717 / 767-3658

★ 3 YEAR ★
LIMITED WARRANTY

WWW.PROAIRLLC.COM

WWW.ACTUSA.US.COM

RELY ON OUR EXPERIENCE TO PROPERLY APPLY YOUR BUS AIR CONDITIONING SYSTEM

Form#CR3 rev12/18 Copyright 2018 Printed in the USA