

Bill of Materials Listing

TransArctic Canada Inc.

7/13/2021
Page 1 of 1

Product Number	Date	Description		Uof M	Weight	Yield	
Line	Qty	Component	Prod#	Rev#	Bin	Unit	
KMC65772	9/24/2013	0	Mt Kit, ISB, 6.7L, BBCV, TM-43+TM-16,'19			86.83	0
5	1	PAC23150				Pack, Carton, 23" x 15" x 10", 51 ECT	each
7	1	BEL61486				Belt, 6gr, 1486mm (58.5") (5060585)	each
10	1	BEL61511				Belt, 6gr, 1511mm (59.5") (5060595)	each
20	1	BMC67063			2	Bkt, Alt, Bar, ISB, F400, BBCV, '10	each
40	1	BMC67071			2	Bkt, Main, 6.7L, ISB, TM-55, BBCV,'10	each
50	1	BMC67072			4	Bkt, Adapt PL, ISB, TM-55/43, BBCV, '10-'13	each
70	1	BMC67105			2	Bkt, Shroud, Cover, ISB, TM-43/31, '10-'13	each
80	2	BMC67107			2	Bkt, Spacer, PI, TM-65/55/43, .06", ALUM	each
85	1	BMC67126			6	Bkt, Main, V Weldmt, TM-65/55/43/31, '13	each
86	1	BMC67131			2	BKT, MAIN, WELDM'T, 6.7L, ISB, COMP, 3	Each
87	1	BMC67188			1	Bkt, Spacer, Block, 1.2", TPK67871	each
90	1	BMZ00099			6	Bkt, Brace, Weldm't, ISB, BBCV, TM-65/55	each
100	2	CLP00040				Clamp, "P" type, #40, 3/4"w, 2 1/2", PC	each
110	1	CLP20014				Clamp, "P" type, #14, 7/8"w, 1", PC	each
112	1	FSP63810			0	Spacer, Fan, Pulley, ISB, 38.10mm(1.5")	each
113	3.50	HOA01002				Hose, Air, 1" ID	feet
114	1	PUL67006			0	Pulley, Crank, ADD-ON, Cum, ISB, 6.7, P6	each
115	2	SCD04812			0	Spacer, Col, Drl, 4.76 mm x 31.8o x 12.3i	each
120	1	TEN80001				Tenr, HD Spring, BackSide, CW (89200D)	each
125	1	TEN80005				Tenr, HD Spring, BackSide, CCW (89430)	each
130	1	KBC65772			0	Bag Kit, Fasteners, KMC65772	each

NOTES:

- 1) The "TURBO TUBE" is rotated "END TO END" when re-installing it back onto the bus.
- 2) Belt runs in the "REAR 6 grooves" of the TM-43 compressor pulley & the "FRONT 6 grooves" of the TM-16 compressor pulley.
- 3) Use blue "Loctite" when installing the (2) Alternator bolts.

Bill of Materials Listing

TransArctic Canada Inc.

7/13/2021
Page 1 of 1

Product Number	Date	Description	Uof M	Weight	Yield	
Line	Qty	Component Prod#	Rev#	Bin	Unit	
KBC65772	4/8/2011	0 Bag Kit, Fasteners, KMC65772			5.94	0
20	2	BTC08030			each	
25	4	BTC08100			each	
30	4	BTC10025			each	
35	1	BTC10030			each	
40	1	BTC10035			each	
43	1	BTC10040			each	
46	1	BTC10045			each	
50	6	BTC10070			each	
55	2	BTC10090			each	
57	6	BTC10130			each	
60	2	BTC10140			each	
70	4	BTC12030			each	
80	1	BTC12040			each	
85	1	BTC12045			each	
86	1	BTP05100			each	
87	1	BTP04100			each	
90	2	CSF08031			each	
100	4	CSF12031			each	
105	6	CSS12090			each	
115	1	NTA10000			each	
117	1	NTA12000			each	
118	1	NTL05003			each	
119	1	NTL04001			each	
120	6	WFA08000			each	
130	16	WFA10000			each	
140	6	WFA12000			each	
145	1	WFA12002			each	
147	1	WFP04000			each	
150	6	WLA08000			each	
160	17	WLA10000			each	
170	6	WLA12000			each	

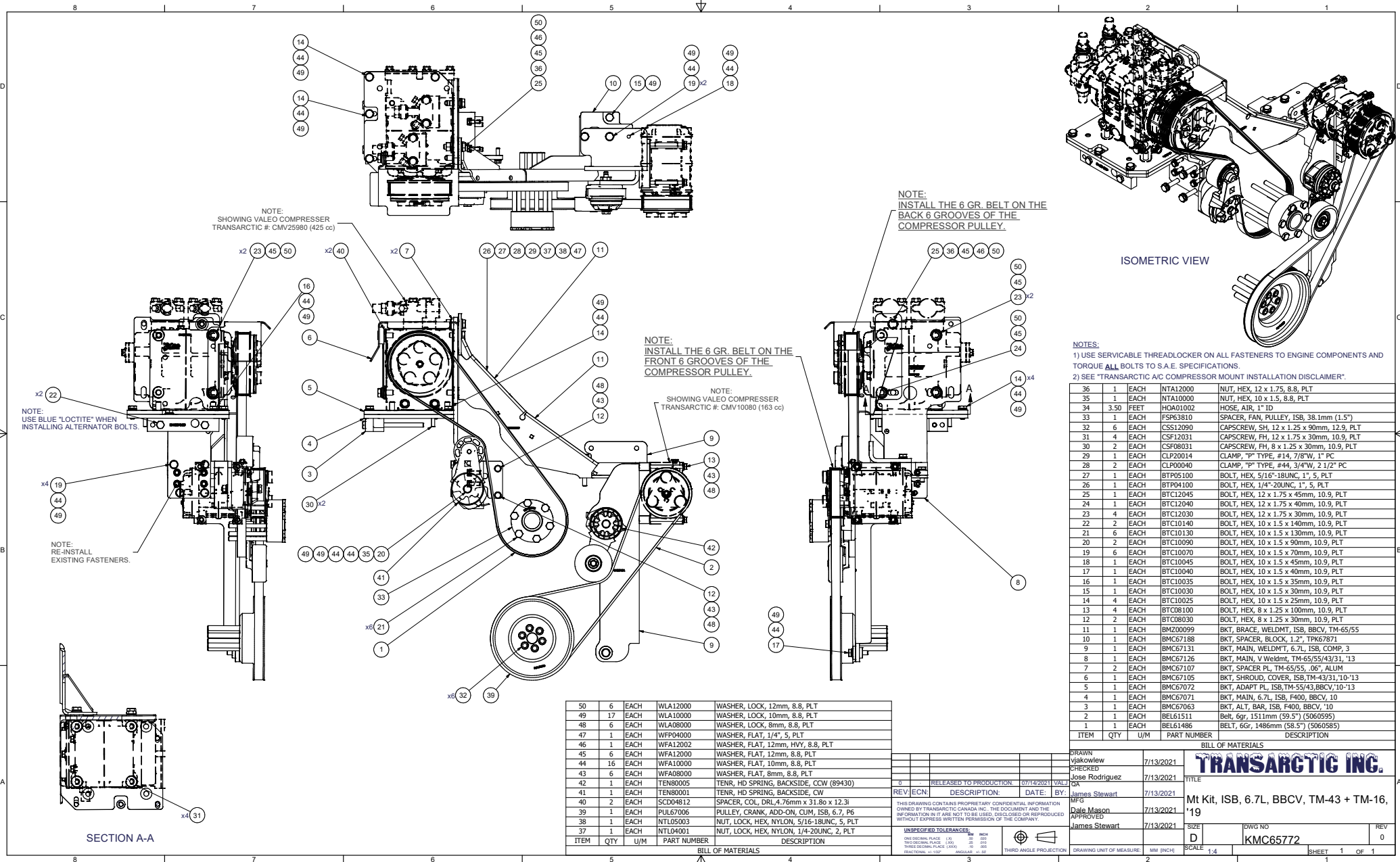

NOTE:
SHOWING VALEO COMPRESSOR
TRANSARC TIC #. CMV25980 (425 cc)

NOTE:
INSTALL THE 6 GR. BELT ON THE
BACK 6 GROOVES OF THE
COMPRESSOR PULLEY.

NOTE:
INSTALL THE 6 GR. BELT ON THE
FRONT 6 GROOVES OF THE
COMPRESSOR PULLEY.

NOTE:
SHOWING VALEO COMPRESSOR
TRANSARC TIC #. CMV10080 (163 cc)

NOTE:
USE BLUE "LOCTITE" WHEN
INSTALLING ALTERNATOR BOLTS.

NOTE:
RE-INSTALL
EXISTING FASTENERS.

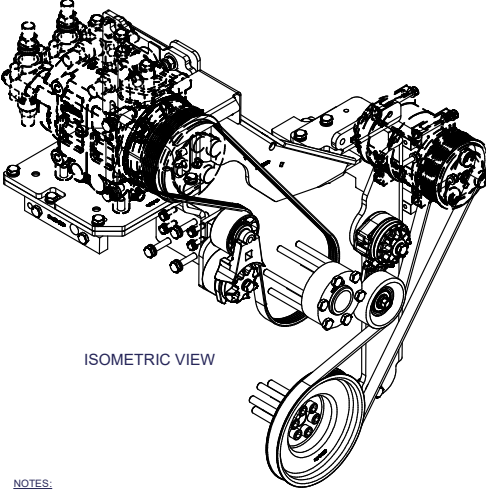

ISOMETRIC VIEW

NOTES:
1) USE SERVICABLE THREADLOCKER ON ALL FASTENERS TO ENGINE COMPONENTS AND TORQUE ALL BOLTS TO S.A.E. SPECIFICATIONS.
2) SEE TRANSARC TIC A/C COMPRESSOR MOUNT INSTALLATION DISCLAIMER:

ITEM	QTY	U/M	PART NUMBER	DESCRIPTION
36	1	EACH	NTA12000	NUT, HEX, 12 x 1.75, 8.8, PLT
35	1	EACH	NTA10000	NUT, HEX, 10 x 1.5, 8.8, PLT
34	3.50	FEET	HOA01002	HOSE, AIR, 1" ID
33	1	EACH	FSP6810	SPACER, FAN, PULLEY, ISB, 38.1mm (1.5")
32	6	EACH	CS12090	CAPSCREW, SH, 12 x 1.25 x 90mm, 12.9, PLT
31	4	EACH	CSF12031	CAPSCREW, FH, 12 x 1.75 x 30mm, 10.9, PLT
30	2	EACH	CSF08031	CAPSCREW, FH, 8 x 1.25 x 30mm, 10.9, PLT
29	1	EACH	CLP20014	CLAMP, "P" TYPE, #14, 7/8"W, 1" PC
28	2	EACH	CLP00040	CLAMP, "P" TYPE, #44, 3/4"W, 2 1/2" PC
27	1	EACH	BTFS100	BOLT, HEX, 5/16"-18UNC, 1", 5, PLT
26	1	EACH	BTFO100	BOLT, HEX, 1/4"-20UNC, 1", 5, PLT
25	1	EACH	BTC12045	BOLT, HEX, 12 x 1.75 x 45mm, 10.9, PLT
24	1	EACH	BTC12040	BOLT, HEX, 12 x 1.75 x 40mm, 10.9, PLT
23	4	EACH	BTC12030	BOLT, HEX, 12 x 1.75 x 30mm, 10.9, PLT
22	2	EACH	BTC10140	BOLT, HEX, 10 x 1.5 x 140mm, 10.9, PLT
21	6	EACH	BTC10130	BOLT, HEX, 10 x 1.5 x 130mm, 10.9, PLT
20	2	EACH	BTC10090	BOLT, HEX, 10 x 1.5 x 90mm, 10.9, PLT
19	6	EACH	BTC10070	BOLT, HEX, 10 x 1.5 x 70mm, 10.9, PLT
18	1	EACH	BTC10045	BOLT, HEX, 10 x 1.5 x 45mm, 10.9, PLT
17	1	EACH	BTC10040	BOLT, HEX, 10 x 1.5 x 40mm, 10.9, PLT
16	1	EACH	BTC10035	BOLT, HEX, 10 x 1.5 x 35mm, 10.9, PLT
15	1	EACH	BTC10030	BOLT, HEX, 10 x 1.5 x 30mm, 10.9, PLT
14	4	EACH	BTC10025	BOLT, HEX, 10 x 1.5 x 25mm, 10.9, PLT
13	4	EACH	BTC08100	BOLT, HEX, 8 x 1.25 x 100mm, 10.9, PLT
12	2	EACH	BTC08030	BOLT, HEX, 8 x 1.25 x 30mm, 10.9, PLT
11	1	EACH	BM200099	BKT, BRACE, WELDMT, ISB, BBCV, TM-65/55
10	1	EACH	BMC67188	BKT, SPACER, BLOCK, 1.2", TPK67871
9	1	EACH	BMC67131	BKT, MAIN, WELDMT, 6.7L, ISB, COMP, 3
8	1	EACH	BMC67126	BKT, MAIN, V WELDMT, TM-65/55/43/31, 13
7	2	EACH	BMC67107	BKT, SPACER, PL, TM-65/55, 06", ALUM
6	1	EACH	BMC67105	BKT, SHROUD, COVER, ISB, TM-43/31, 10"-13
5	1	EACH	BMC67072	BKT, ADAPT, PL, ISB, TM-55/43, BBCV, 10"-13
4	1	EACH	BMC67071	BKT, MAIN, 6.7L, ISB, F400, BBCV, 10
3	1	EACH	BMC67063	BKT, ALT, BAR, ISB, F400, BBCV, 10
2	1	EACH	BEL61511	Belt, 6gr, 1511mm (59.5") (5060595)
1	1	EACH	BEL61486	BELT, 6Gr, 1486mm (58.5") (5060585)

ITEM	QTY	U/M	PART NUMBER	DESCRIPTION
50	6	EACH	WLA12000	WASHER, LOCK, 12mm, 8.8, PLT
49	17	EACH	WLA10000	WASHER, LOCK, 10mm, 8.8, PLT
48	6	EACH	WLA08000	WASHER, LOCK, 8mm, 8.8, PLT
47	1	EACH	WFP04000	WASHER, FLAT, 1/4", 5, PLT
46	1	EACH	WFA12002	WASHER, FLAT, 12mm, HVY, 8.8, PLT
45	6	EACH	WFA12000	WASHER, FLAT, 12mm, 8.8, PLT
44	16	EACH	WFA10000	WASHER, FLAT, 10mm, 8.8, PLT
43	6	EACH	WFA08000	WASHER, FLAT, 8mm, 8.8, PLT
42	1	EACH	TEN80005	TENR, HD SPRING, BACKSIDE, CCW (89430)
41	1	EACH	TEN80001	TENR, HD SPRING, BACKSIDE, CW
40	2	EACH	SCD04812	SPACER, COL, DRL, 4.76mm x 31.80 x 12.31
39	1	EACH	PUL67006	PULLEY, CRANK, ADD-ON, CUM, ISB, 6.7, P6
38	1	EACH	NTL05003	NUT, LOCK, HEX, NYLON, 5/16-18UNC, 5, PLT
37	1	EACH	NTL04001	NUT, LOCK, HEX, NYLON, 1/4-20UNC, 2, PLT

ITEM	QTY	U/M	PART NUMBER	DESCRIPTION
36	1	EACH	NTA12000	NUT, HEX, 12 x 1.75, 8.8, PLT
35	1	EACH	NTA10000	NUT, HEX, 10 x 1.5, 8.8, PLT
34	3.50	FEET	HOA01002	HOSE, AIR, 1" ID
33	1	EACH	FSP6810	SPACER, FAN, PULLEY, ISB, 38.1mm (1.5")
32	6	EACH	CS12090	CAPSCREW, SH, 12 x 1.25 x 90mm, 12.9, PLT
31	4	EACH	CSF12031	CAPSCREW, FH, 12 x 1.75 x 30mm, 10.9, PLT
30	2	EACH	CSF08031	CAPSCREW, FH, 8 x 1.25 x 30mm, 10.9, PLT
29	1	EACH	CLP20014	CLAMP, "P" TYPE, #14, 7/8"W, 1" PC
28	2	EACH	CLP00040	CLAMP, "P" TYPE, #44, 3/4"W, 2 1/2" PC
27	1	EACH	BTFS100	BOLT, HEX, 5/16"-18UNC, 1", 5, PLT
26	1	EACH	BTFO100	BOLT, HEX, 1/4"-20UNC, 1", 5, PLT
25	1	EACH	BTC12045	BOLT, HEX, 12 x 1.75 x 45mm, 10.9, PLT
24	1	EACH	BTC12040	BOLT, HEX, 12 x 1.75 x 40mm, 10.9, PLT
23	4	EACH	BTC12030	BOLT, HEX, 12 x 1.75 x 30mm, 10.9, PLT
22	2	EACH	BTC10140	BOLT, HEX, 10 x 1.5 x 140mm, 10.9, PLT
21	6	EACH	BTC10130	BOLT, HEX, 10 x 1.5 x 130mm, 10.9, PLT
20	2	EACH	BTC10090	BOLT, HEX, 10 x 1.5 x 90mm, 10.9, PLT
19	6	EACH	BTC10070	BOLT, HEX, 10 x 1.5 x 70mm, 10.9, PLT
18	1	EACH	BTC10045	BOLT, HEX, 10 x 1.5 x 45mm, 10.9, PLT
17	1	EACH	BTC10040	BOLT, HEX, 10 x 1.5 x 40mm, 10.9, PLT
16	1	EACH	BTC10035	BOLT, HEX, 10 x 1.5 x 35mm, 10.9, PLT
15	1	EACH	BTC10030	BOLT, HEX, 10 x 1.5 x 30mm, 10.9, PLT
14	4	EACH	BTC10025	BOLT, HEX, 10 x 1.5 x 25mm, 10.9, PLT
13	4	EACH	BTC08100	BOLT, HEX, 8 x 1.25 x 100mm, 10.9, PLT
12	2	EACH	BTC08030	BOLT, HEX, 8 x 1.25 x 30mm, 10.9, PLT
11	1	EACH	BM200099	BKT, BRACE, WELDMT, ISB, BBCV, TM-65/55
10	1	EACH	BMC67188	BKT, SPACER, BLOCK, 1.2", TPK67871
9	1	EACH	BMC67131	BKT, MAIN, WELDMT, 6.7L, ISB, COMP, 3
8	1	EACH	BMC67126	BKT, MAIN, V WELDMT, TM-65/55/43/31, 13
7	2	EACH	BMC67107	BKT, SPACER, PL, TM-65/55, 06", ALUM
6	1	EACH	BMC67105	BKT, SHROUD, COVER, ISB, TM-43/31, 10"-13
5	1	EACH	BMC67072	BKT, ADAPT, PL, ISB, TM-55/43, BBCV, 10"-13
4	1	EACH	BMC67071	BKT, MAIN, 6.7L, ISB, F400, BBCV, 10
3	1	EACH	BMC67063	BKT, ALT, BAR, ISB, F400, BBCV, 10
2	1	EACH	BEL61511	Belt, 6gr, 1511mm (59.5") (5060595)
1	1	EACH	BEL61486	BELT, 6Gr, 1486mm (58.5") (5060585)

REV: 0	RELEASED TO PRODUCTION: 07/14/2021	VAL: CR
REV: ECN	DESCRIPTION:	DATE: BY:
		James Stewart 7/13/2021
		DATE: BY: 7/13/2021
		James Stewart 7/13/2021

DRAWN: vjakowlew 7/13/2021
 CHECKED: Jose Rodriguez 7/13/2021
 APPROVED: Dale Mason 7/13/2021
 APPROVED: James Stewart 7/13/2021

TRANSARC TIC INC.
 TITLE: Mt Kit, ISB, 6.7L, BBCV, TM-43 + TM-16, '19
 DWG NO: KMC65772
 SCALE: 1:4
 SHEET 1 OF 1

SECTION A-A

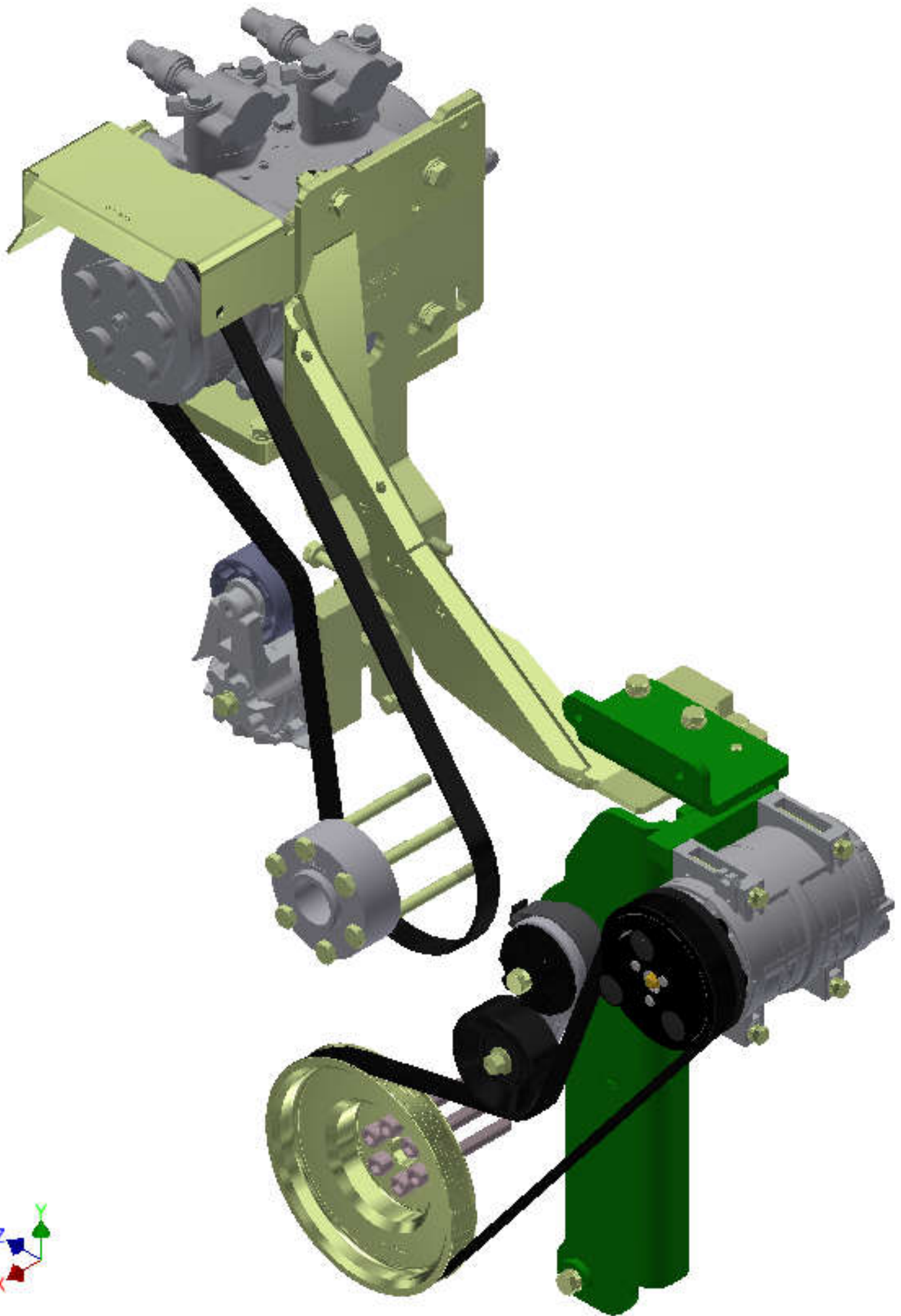

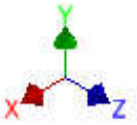
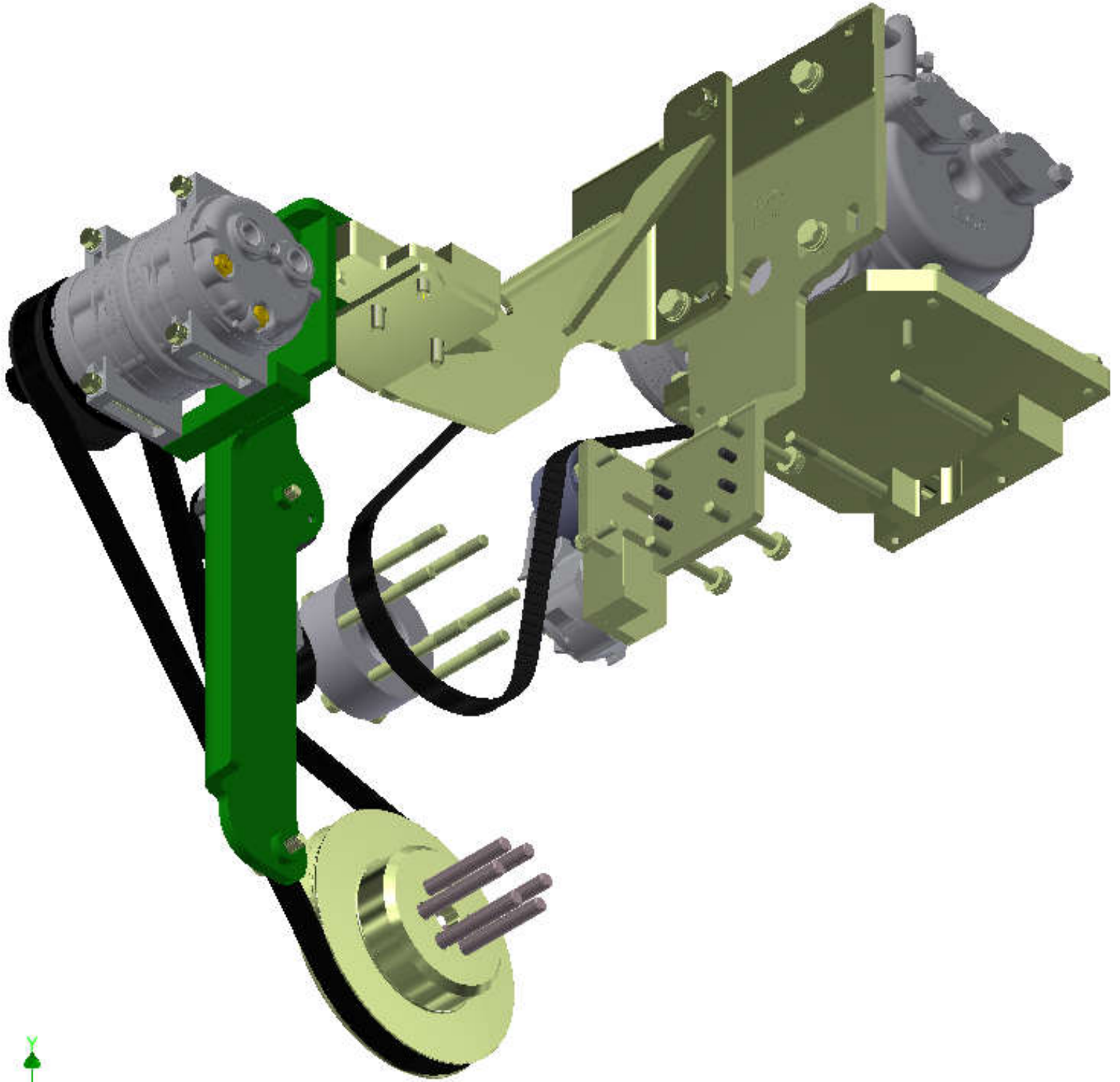

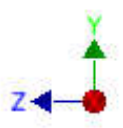
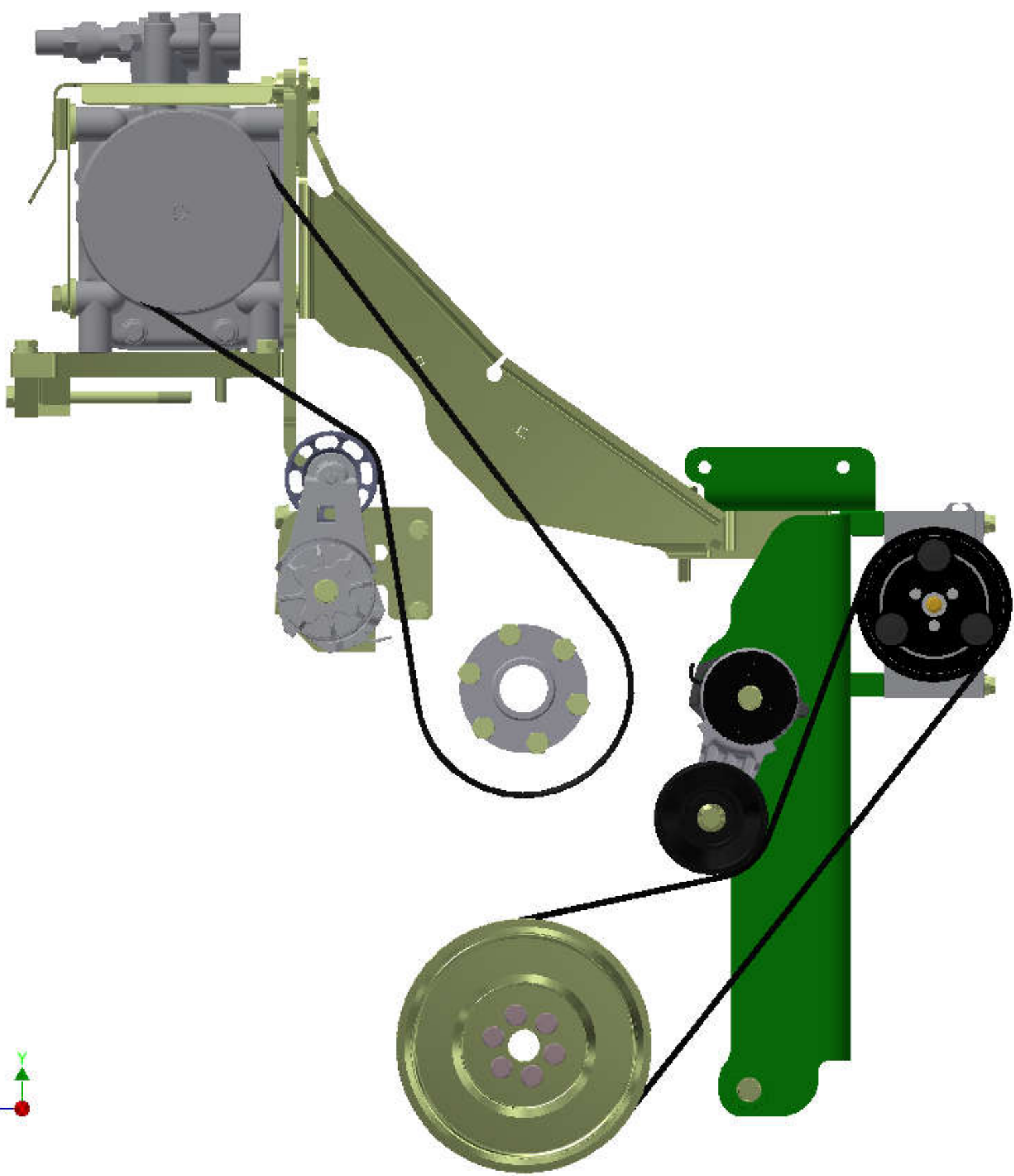

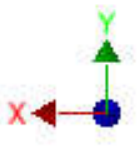
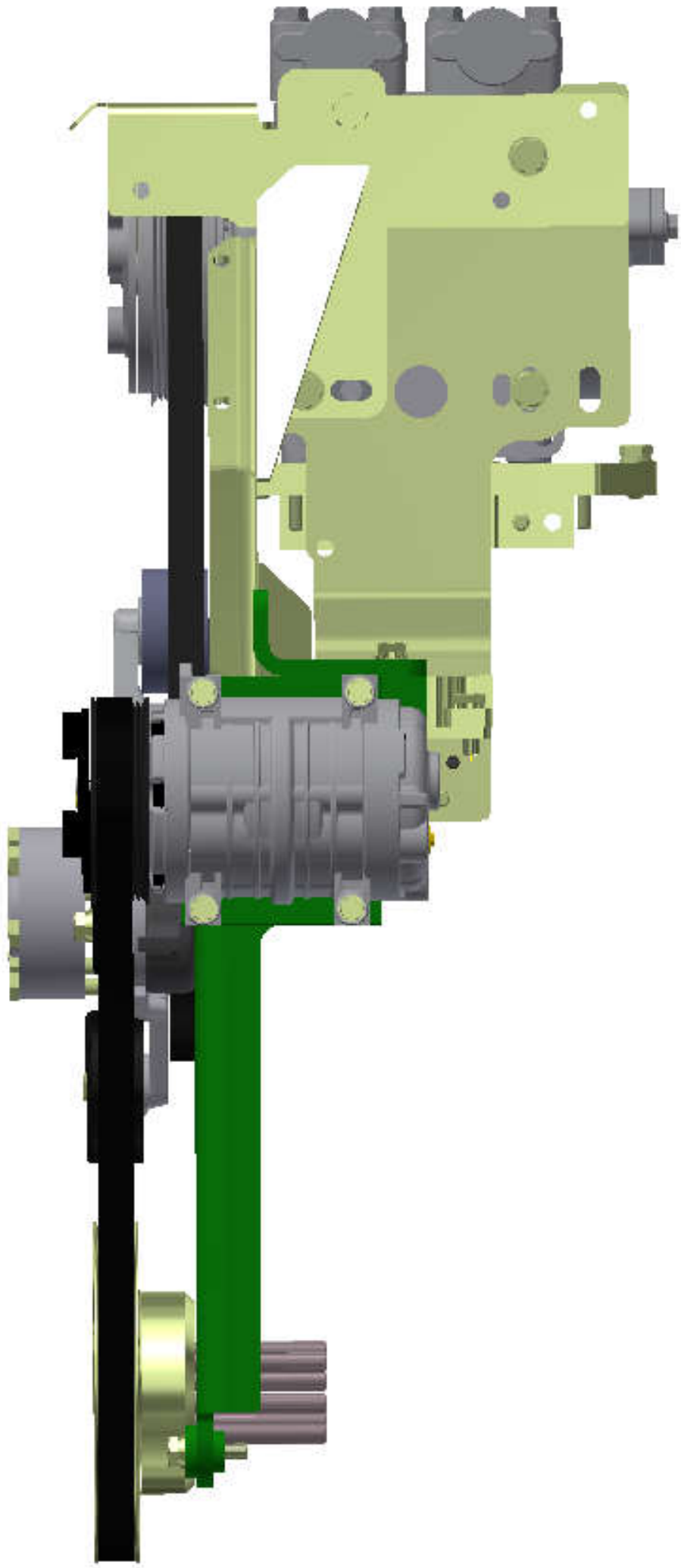

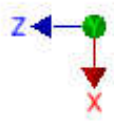
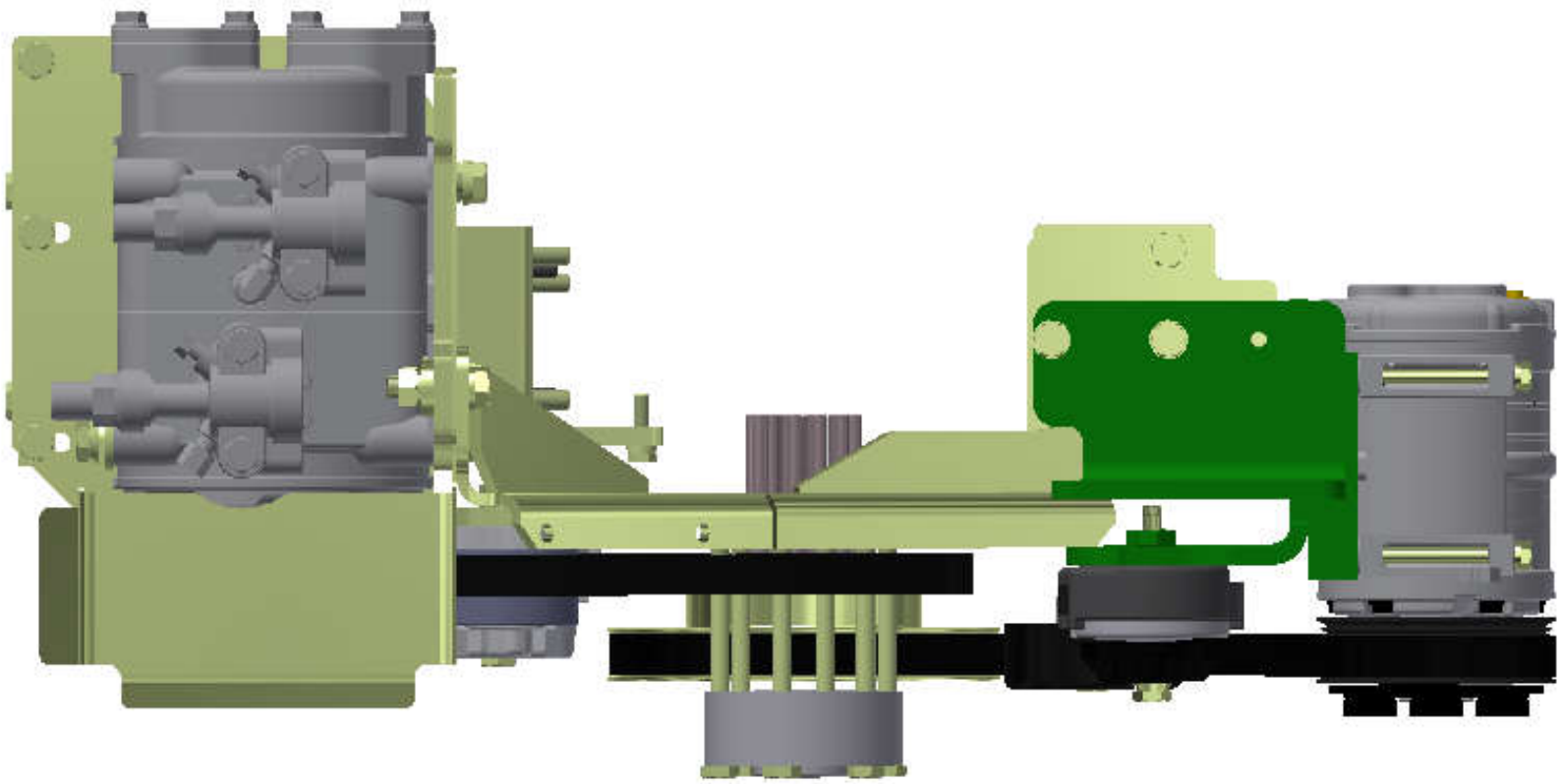

TransArctic A/C Compressor Mount Installation Disclaimer

All compressor mounts should be installed by qualified and trained personnel using proper tools and equipment in safe working conditions following industry standard guidelines for motor vehicle service and repair.

The installer of any compressor mount purchased from TransArctic must undertake all responsibility of issues arising from that compressor bracket being installed on any vehicle. As well as insure that a **proper and sufficient ground** is established between the compressors' clutches and the vehicle's engine. Mount functionality, operation and durability can all be compromised by an incompetent installation.

Due to the many different situations, parameters and application criteria, which are beyond the compressor mount manufacturer's control, TransArctic does not warrant design, durability, or operational functionality of any compressor mount improperly installed by another party.

With no implied guarantees it is the mount installer's strict responsibility to determine safety and functionality, of the compressor mount, at the time of installation.

Please contact TransArctic with any issue arising from installation so we may better improve the product. If you have any reservations about the compressor mount integrity contact TransArctic immediately at 1-877-COLD-AIR.

Mark OEM tensioner location

Install Kit

Check for Interferences

Check to ensure that the proper OEM tensioner orientation is maintained

Run engine with A/C system engaged for at least 10 minutes to run in belt

Check OEM tensioner orientation and adjust as required

Responsabilidad limitada de TransArctic en la instalación del soporte del compresor

Todos los soportes de los compresores deben ser instalados por personas calificadas y entrenadas, usando para ello los equipos y herramientas necesarios para esta labor en buenas condiciones y según las normas y guías para el servicio y/o reparación de motores de vehículos.

El instalador de los soportes comprados en TransArctic asume toda la responsabilidad de cualquier problema que surga en el soporte del compresor al vehículo; de igual manera es responsable que el cable a tierra sea conectado entre el embrague del compresor y el motor del vehículo.

Se advierte que el buen funcionamiento y la durabilidad del soporte pueden ser comprometidos por defectos en su instalación.

Debido a las diversas situaciones que se puedan presentar fuera del control del fabricante, TransArctic no garantiza el diseño, la durabilidad o el correcto funcionamiento de cualquier equipo inapropiadamente instalado por terceros.

Esta sobreentendido que el Instalador del montaje del compresor es estrictamente responsable de la seguridad y funcionamiento del equipo en el momento de la instalación.

Si tuviera algún problema o duda acerca de la instalación del soporte del compresor pongase en contacto inmediatamente con TransArctic al teléfono 1-877-COLD-AIR de modo que podamos mejorar nuestro producto.

Note la ubicación del medidor de tensión OEM

Instale el equipo

Controlar si hay interferencias.

Asegurese que el medidor de tensión mantenga la orientación justa.

Encienda el motor por lo menos 10 minutos con el sistema A/C enganchado para que la correa corra

Controle la orientación justa del medidor de tensión y ajuste a las condiciones requeridas del fabricante