

# Bill of Materials Listing

TransArctic Canada Inc.

7/5/2017  
Page 1 of 1

Product Number	Description	Date	Weight	Uof M	Yield
Line    Component    Prod#	Description	Bin                    Unit	Qty		
<b>KMC83994</b>	<b>Mt Kit, ISL-D, HDX, 4xFC, '13-'16</b>		<b>9/6/2013</b>	<b>145.31</b>	<b>0</b>
10	BEL32389		Belt, Banded B gr, 2388mm (94")	each	1
20	BMC83123		Bkt, Main, Idler, Weldm't, ISL, HDX, '13	each	1
30	BMC83125		Bkt, Weldm't, Adapter Pl, ISL, HDX, '13	each	1
40	BMC83129		Bkt, Weldm't, Main Base, ISL, HDX, '13	each	1
50	KCB83994		Kit, Compressor, PS, 4xFC, '13	each	1
60	KPC89022		Kit, Pulley, ISL, 8.9L, 2B/X,'13	each	1
70	PUA05012		Pulley, Assy, Idler,B/BX gr,5", STL,Plt	each	1
80	PUL80074		Pulley, Idler, B/S, Wide, 76d (89102)	each	1
90	SCD21912		Spacer, Col, Drl,21.9mm x 25.4o x 12.3i	each	1
95	SCD25412		Spacer, Col, Drl,25.4mm x 25.4o x 12.3i	each	1
100	SLV17012		Sleeve, Pulley, 16.9o x 22.23mm x 12.32i	each	2
110	KBC84094		Bag Kit,Fasteners,KMC840/39/4194-9/62494	each	1

# Bill of Materials Listing

TransArctic Canada Inc.

4/25/2017  
Page 1 of 1

Product Number		Description	Bin	Date	Weight	Uof M	Yield
Line	Component Prod#	Description		Unit	Qty		
<b>KBC84094</b>		<b>Bag Kit, Fasteners, KMC840/39/4194-9/62494</b>		<b>9/11/2013</b>	<b>2.32</b>		<b>0</b>
10	BTC10045	Bolt, Hex, 10 x 1.5 x 45mm, 10.9, Plt, FT		each	3		
30	BTC12080	Bolt, Hex, 12 x 1.75 x 80mm, 10.9, Plt, FT		each	2		
40	BTQ06175	Bolt, Hex, 3/8-16unc, 1.75", 8, Plt		each	5		
50	BTQ08125	Bolt, Hex, 1/2-13unc, 1.25", 8, Plt		each	2		
60	BTQ08151	Bolt, Hex, 1/2-20unf, 1.5", 8, Plt		each	2		
70	CSF08101	Capscrew, FH, 1/2-20unf x 1.0", Alloy, Plt		each	4		
80	NTA10000	Nut, Hex, 10 x 1.5, 8.8, Plt		each	3		
90	NTA12000	Nut, Hex, 12 x 1.75, 8.8, Plt		each	2		
100	NTQ06000	Nut, Hex, 3/8-16unc, 8, Plt		each	5		
110	WFA10002	Washer, Flat, 10mm, Hvy, 8.8, Plt		each	6		
120	WFA12000	Washer, Flat, 12mm, 8.8, Plt		each	1		
125	WFA12002	Washer, Flat, 12mm, Hvy, 8.8, Plt		each	1		
130	WFS06002	Washer, Flat, 3/8", L9, Plt		each	10		
140	WFQ08000	Washer, Flat, 1/2", 8, Plt		each	4		
150	WLA10000	Washer, Lock, 10mm, 8.8, Plt		each	3		
160	WLA12000	Washer, Lock, 12mm, 8.8, Plt		each	2		
170	WLQ06000	Washer, Lock, 3/8", 8, Plt		each	5		
180	WLQ08000	Washer, Lock, 1/2", 8, Plt		each	4		

# Bill of Materials Listing

TransArctic Canada Inc.

3/4/2015  
Page 1 of 1

Product Number	Description	Date	Weight	Uof M	Yield
Line    Component    Prod#	Description	Bin                    Unit	Qty		
<b>KCB83994</b>	<b>Kit, Comp, 12V, ISL, HDX, FK40/ 4xFC,'13</b>	<b>11/14/13</b>	<b>54.71</b>		<b>0</b>
10 BMN80008	Vibration Isolator, Bar,16.50 x 2 x 1.50	each	2		
20 BMN80025	Bkt, Back, PL, Slide, IC, RE300	each	1		
30 BMZ00043	Bkt, Main, Base Pl, '13	each	1		
40 KBT83990	Kit, Platform, 4xFCY, '12	each	1		
50 KBZ83994	Bag Kit, Fasteners, KCB83994	each	1		

# Bill of Materials Listing

TransArctic Canada Inc.

3/4/2015  
Page 1 of 1

Product Number	Description	Date	Weight	Uof M	Yield
Line    Component    Prod#	Description	Bin            Unit	Qty		
<b>KBZ83994</b>	<b>Bag Kit, Fasteners, KCB83994</b>	<b>11/14/13</b>	<b>1.06</b>		<b>0</b>
10 BTP08653	Bolt, Hex, 1/2-13unc, 6.5", 5, Plt, FT	each	1		
20 BTQ08101	Bolt, Hex, 1/2-20unf, 1.00", 8, Plt	each	4		
30 CSF08076	Capscrew, FH, 1/2-20unf x .75", Alloy, Plt	each	2		
40 WFQ08000	Washer, Flat, 1/2", 8, Plt	each	4		
50 WLQ08000	Washer, Lock, 1/2", 8, Plt	each	5		

# Bill of Materials Listing

TransArctic Canada Inc.

3/4/2015  
Page 1 of 1

Product Number	Description		Date	Weight	Uof M	Yield
Line    Component    Prod#	Description	Bin	Unit	Qty		
<b>KBT83990</b>	<b>Kit, Platform, 4xFCY, '12</b>		<b>02/17/09</b>	<b>15.25</b>		<b>0</b>
10 BMN80031	Bkt, Main, Slide, Assy, 05K, IC, RE300		each	1		
20 BMZ00036	Bkt, Adaptor, Weld't, 4xFCY		each	1		
30 KBZ00010	Bag Kit, Fasteners, KBT84094/83990		each	1		

# Bill of Materials Listing

TransArctic Canada Inc.

3/4/2015  
Page 1 of 1

Product Number	Description	Date	Weight	Uof M	Yield
Line    Component    Prod#	Description	Bin            Unit	Qty		
<b>KBZ00010</b>	<b>Bag Kit, Fasteners, KBT84094/83990</b>	<b>11/06/13</b>	<b>1.23</b>		<b>0</b>
10	BTC12040				
	Bolt, Hex, 12 x 1.75 x 40mm, 10.9,Plt,FT	each	4		
15	BTC12060				
	Bolt, Hex, 12 x 1.75 x 60mm, 10.9,Plt,FT	each	4		
20	NTP07000				
	Nut, Hex, 7/16-14unc, 5, Plt	each	4		
30	WFA12000				
	Washer, Flat, 12mm, 8.8, Plt	each	8		
40	WFN07000				
	Washer, Flat, 7/16", 2, Plt	each	4		
50	WLA12000				
	Washer, Lock, 12mm, 8.8, Plt	each	4		
60	WLP07000				
	Washer, Lock, 7/16", 5, Plt	each	4		

# Bill of Materials Listing

TransArctic Canada Inc.

3/4/2015  
Page 1 of 1

Product Number	Description	Date	Weight	Uof M	Yield
Line    Component    Prod#	Description	Bin                    Unit	Qty		
<b>KPC89022</b>	<b>Kit, Pulley, ISL, 8.9L, 2B/X,'13</b>		<b>10/15/13</b>	<b>11.51</b>	<b>0</b>
10	PUL89022		Pulley, Crank, ISL, 8.9L, 2B/X, 8", '13	each	1
20	BTC10050		Bolt, Hex, 10 x 1.5 x 50mm, 10.9, Plt	each	5
30	WFA10000		Washer, Flat, 10mm, 8.8, Plt	each	5

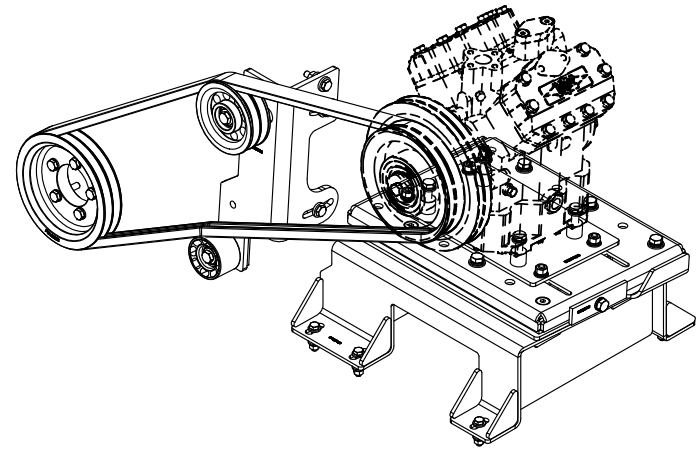
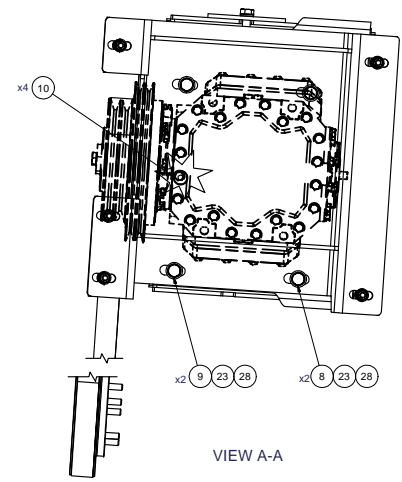
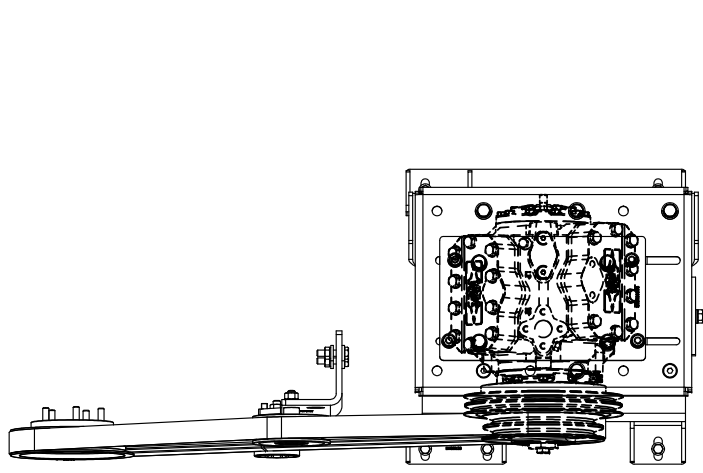

ISOMETRIC VIEW

VIEW A-A

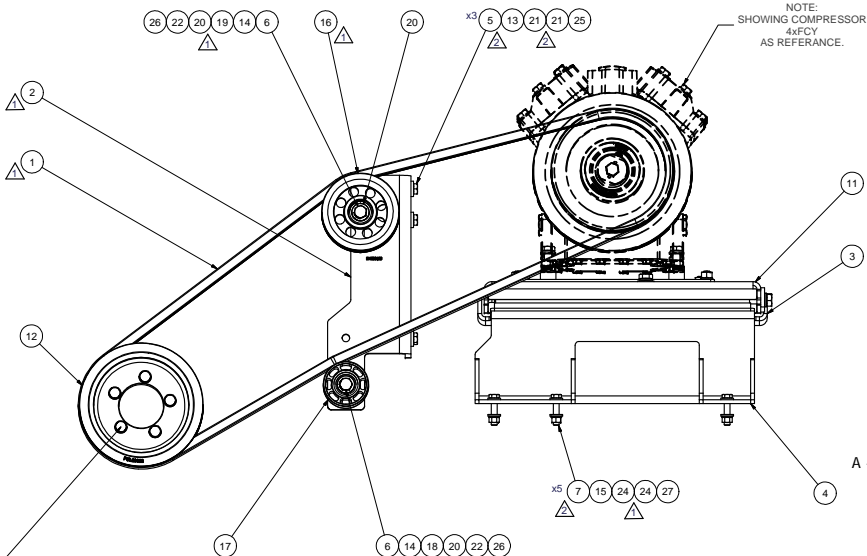

NOTE:  
SHOWING COMPRESSOR  
4xFCY  
AS REFERENCE.

NOTE:  
TORQUE TO: 48 FT-LB PLAIN & LUBRICATED W/ CLEAN ENGINE OIL (15W-40)  
(HEX BOLT CAPSCREW M10 x 1.5 x 50mm)  
TIGHTEN IN TWO STEPS IN A CRIS-CROSS TIGHTENING SEQUENCE PATTERN.

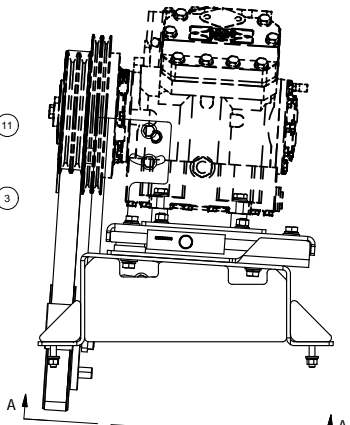

NOTES:

- 1) USE SERVICABLE THREADLOCKER ON ALL FASTENERS TO ENGINE COMPONENTS AND TORQUE ALL BOLTS TO S.A.E. SPECIFICATIONS.
- 2) SEE "TRANSARGTIC A/C COMPRESSOR MOUNT INSTALLATION DISCLAIMER".

ITEM	QTY	U/M	PART NUMBER	DESCRIPTION
26	4	EACH	WL008000	WASHER, LOCK, 1/2", 8, PLT
27	5	EACH	WL006000	WASHER, LOCK, 3/8", 8, PLT
26	2	EACH	WL120000	WASHER, LOCK, 12mm, 8.8, PLT
25	3	EACH	WL100000	WASHER, LOCK, 10mm, 8.8, PLT
24	10	EACH	WFS06002	WASHER, FLAT, 3/8", L9, PLT
23	4	EACH	WFO08000	WASHER, FLAT, 1/2", 8, PLT
22	2	EACH	WFA12000	WASHER, FLAT, 12mm, 8.8, PLT
21	6	EACH	WFA10002	WASHER, FLAT, 10mm, HWY, 8.8, PLT
20	2	EACH	SLV17012	SLEEVE, PULLEY, 16.90 x 22.23 mm x12.19l
19	1	EACH	SCD25412	SPACER, COL, DRL, 25.4mm x 25.40 x 12.3l
18	1	EACH	SCD21912	SPACER, COL, DRL, 21.9mm x 31.80 x12.3l
17	1	EACH	PUL80074	PULLEY, IDLER, BACKSIDE, P8, 74D, 46.27W
16	1	EACH	PIA05012	PULLEY, ASSY, IDLER, B/BX gr, 5" STL, PLT
15	5	EACH	NT006000	NUT, HEX, 3/8-16UNC, 8, PLT
14	2	EACH	NTA12000	NUT, HEX, 12 x 1.75, 8.8, PLT
13	3	EACH	NTA10000	NUT, HEX, 10 x 1.5, 8.8, PLT
12	1	EACH	KPC89022	KIT, PULLEY, ISL, 8.9L, 2B/X, '13
11	1	EACH	KCB83994	KIT, COMPRESSOR, PS, 4xFC, '13
10	4	EACH	CSF08101	CAPSCREW, FH, 1/2-20UNF x 1", ALLOY, PLT
9	2	EACH	BTQ08151	BOLT, HEX, 1/2-20UNF x 1.50, 8, PLT
8	2	EACH	BTQ08125	BOLT, HEX, 1/2-13UNC x 1.25, 8, PLT
7	5	EACH	BTQ06175	BOLT, HEX, 3/8-16UNC, 1.75", 8, PLT
6	2	EACH	BTC12080	BOLT, HEX, 12 x 1.75 x 80mm, 10.9, PLT
5	3	EACH	BTC10045	BOLT, HEX, 10 x 1.5 x 45mm, 10.9, PLT
4	1	EACH	BMC83129	BKT, WELDMT, MAIN BASE, ISL, HDX, '13
3	1	EACH	BMC83125	BKT, WELDMT, ADAPTER PL, ISL, HDX, '13
2	1	EACH	BMC83123	BKT, MAIN, IDLER, WELDMT, ISL, HDX, '13
1	1	EACH	BEL32388	BELT, BANDED B gr, 2388mm (9'4")

BILL OF MATERIALS

2	REVISED FASTENER/CRANK/ROCK	4/20/2017	JRR
1	GENERAL REVISION	7/22/2016	JRR
0	RELEASED TO PRODUCTION	3/2/2013	JRR
REV/ECN	DESCRIPTION	DATE	BY
			Jaymes Stewart
			Ron Ingram
			Dale Mason

**TRANSARGTIC INC.**

MT KIT, ISL-D, HDX, 4xFC, '13-'16

UNSPECIFIED TOLERANCES:	ALL DIMS	THIRD ANGLE PROJECTION
ONE DECIMAL PLACE (X.0)	FRAC	
TWO DECIMAL PLACES (X.00)	FRAC	
THREE DECIMAL PLACES (X.000)	FRAC	
FRACTIONAL (1/16")	ANGULAR	

DRAWN	JRodriguez	3/2/2015	CHECKED	
DATE			DATE	
SCALE	1:4	DWG NO	KMC83994	REV
				2
				SHEET 1 OF 1



**TOP VIEW**

PARTS REMOVED FOR CLARITY.

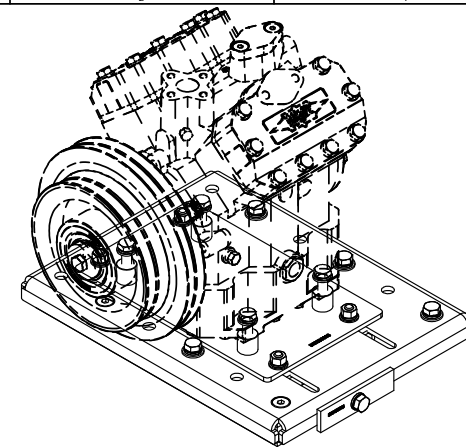
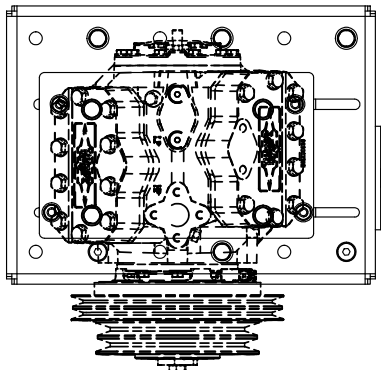
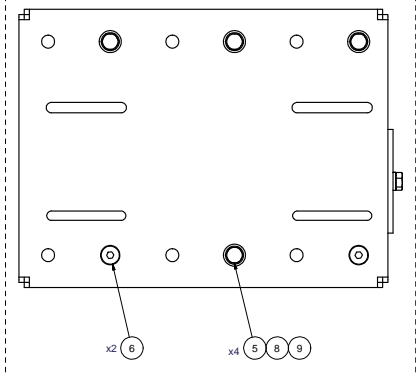

**ISOMETRIC VIEW**

NOTE:  
SHOWING COMPRESSOR  
4xFCY  
AS REFERENCE.

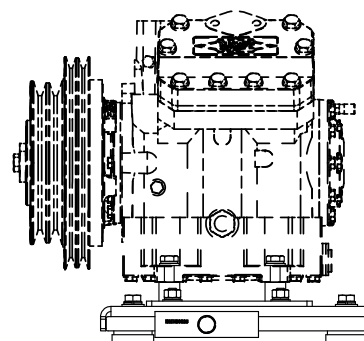
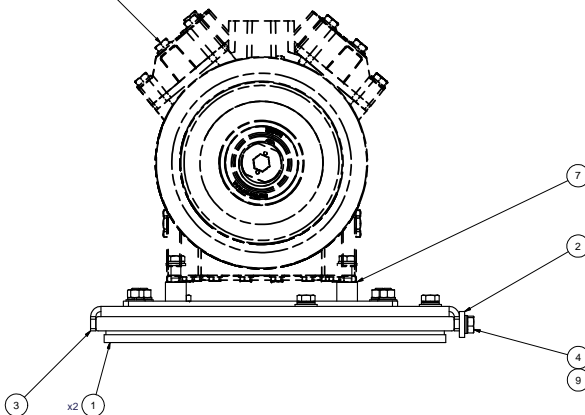

- NOTES:**
- 1) USE SERVICABLE THREADLOCKER ON ALL FASTENERS TO ENGINE COMPONENTS AND TORQUE ALL BOLTS TO S.A.E. SPECIFICATIONS.
  - 2) SEE "TRANSARCTIC A/C COMPRESSOR MOUNT INSTALLATION DISCLAIMER".
  - 3) WEIGHT: 50.93 LBS.

ITEM	QTY	U/M	PART NUMBER	DESCRIPTION
9	5	EACH	WLO08000	WASHER, LOCK, 1/2", 8, PLT
8	4	EACH	WFO08000	WASHER, FLAT, 1/2", 8, PLT
7	1	EACH	KBT83990	MT KIT, TRANSIT, 4xFCY, '12
6	2	EACH	CSF08076	CAPSCREW, FH, 1/2-20UNF x .75", ALLOY, PLT
5	4	EACH	BTQ08101	BOLT, HEX, 1/2-20UNF x 1.00, 5, PLT
4	1	EACH	BTP08653	BOLT, HEX, 1/2-13UNC x 6.50, 5, PLT, FT
3	1	EACH	BMZ00043	BKT, MAIN, BASE PL, '13
2	1	EACH	BMN80025	BKT, BACK, PL, SLIDE, IC, RE300
1	2	EACH	BMN80008	VIBRATION ISOLATOR, BAR, 1x.50 x 2 x 1.50

**BILL OF MATERIALS**

DRAWN	JRodriguez	3/3/2015		
CHECKED	Jose Rodriguez	3/3/2015		
REV	ECN	DESCRIPTION	DATE	BY
0		RELEASED TO PRODUCTION	3/3/15	JRR
1		UPDATED NOTE/TITLE	3/26/17	JRR
2		APPROVED	3/3/2015	James Stewart
3		APPROVED	3/3/2015	Dale Mason

**TRANSARCTIC INC.**

**KIT, COMPRESSOR, PS, 4xFC, '13**

UNSPECIFIED TOLERANCES:		ALL DIMS
ONE DECIMAL PLACE	(X)	.005
TWO DECIMAL PLACES	(X)	.002
THREE DECIMAL PLACES	(X)	.001
FRACTIONAL (1/16")	(X)	.001
ANGULAR	(X)	.01



DWG NO	KCB83994	REV	1
SIZE	D	SHEET	1 OF 1
DRAWING UNIT OF MEASURE	MM (INCH)	SCALE	1:3

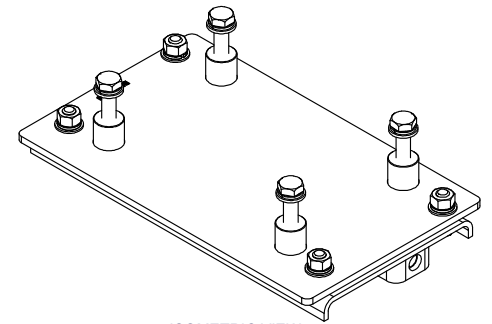
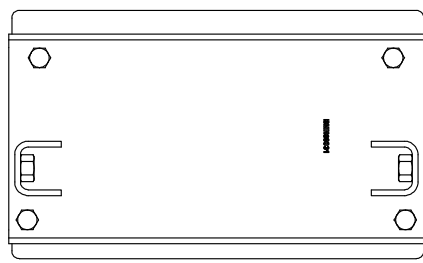
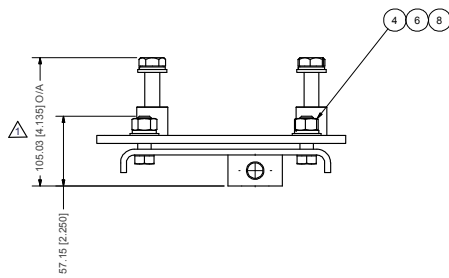
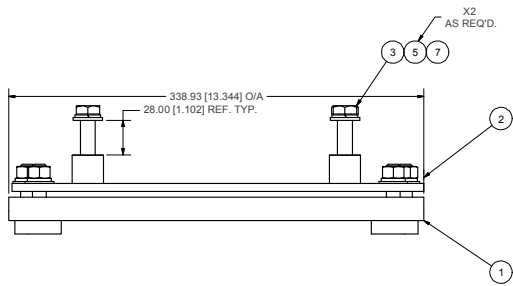
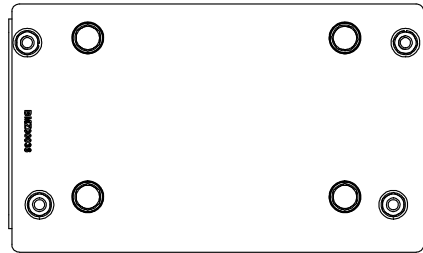

ISOMETRIC VIEW

- NOTES:**
- 1) USE SERVICABLE THREADLOCKER ON ALL FASTENERS TO ENGINE COMPONENTS AND TORQUE **ALL** BOLTS TO S.A.E. SPECIFICATIONS.
  - 2) SEE "TRANSARTIC A/C COMPRESSOR MOUNT INSTALLATION DISCLAIMER".
  - 3) WEIGHT: 15.17 LBS.

ITEM	QTY	U/M	PART NUMBER	DESCRIPTION
8	4	EACH	WLP07000	WASHER, LOCK, 7/16", 5, PLT
7	4	EACH	WLA12000	WASHER, LOCK, 12mm, 8.8, PLT
6	4	EACH	WFN07000	WASHER, FLAT, 7/16", 2, PLT
5	8	EACH	WFA12000	WASHER, FLAT, 12mm, 8.8, PLT
4	4	EACH	NTP07000	NUT, HEX, 7/16-14UNC, 5, PLT
3	4	EACH	BTC12060	BOLT, HEX, 1/2 x 1.75 x 60mm, 10.9, PLT
2	1	EACH	BM200036	BKT, ADAPTER, WELD'T, 4xFCY
1	1	EACH	BMN80031	BKT, MAIN, SLIDE, ASSY, 05K, IC, RE300

**TRANSARTIC INC.**

0	O/A WAS 96.0mm, BOM UPDATED	4/24/2013	JHP	
0	RELEASED TO PRODUCTION	3/14/2012	VAL	
REV	ECN	DESCRIPTION	DATE	BY
				James Stewart
				Ron Ingram
				Dale Mason

THIS DRAWING CONTAINS PROPRIETARY CONFIDENTIAL INFORMATION OWNED BY TRANSARTIC CANADA INC. THE DOCUMENT AND THE INFORMATION IN IT ARE NOT TO BE USED, DISCLOSED OR REPRODUCED WITHOUT EXPRESS WRITTEN PERMISSION OF THE COMPANY.

**UNSPECIFIED TOLERANCES:** (ALL DIM)  
 ONE DECIMAL PLACE (10) .10  
 TWO DECIMAL PLACE (20) .02  
 FRACTIONAL (1/32) .03125

DRAWN		3/13/2012	TITLE	
CHECKED			MT KIT, TRANSIT, 4xFCY, '12	
DATE		3/13/2012	SIZE	DWG NO
APPROVED			D	KBT83990
DATE		3/13/2012	SCALE	1:2
DRAWING UNIT OF MEASURE		MM (INCH)	SHEET	1 OF 1



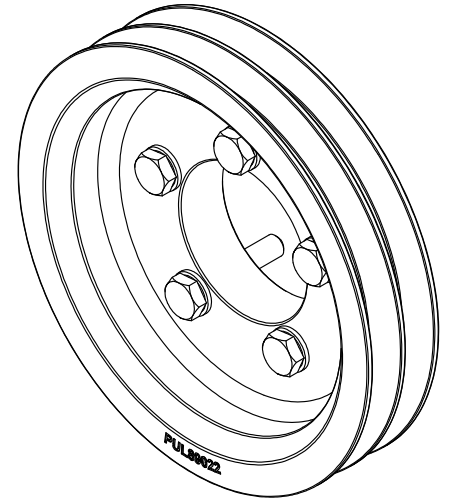
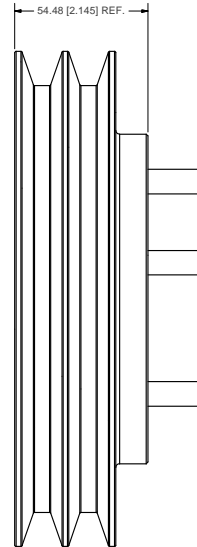
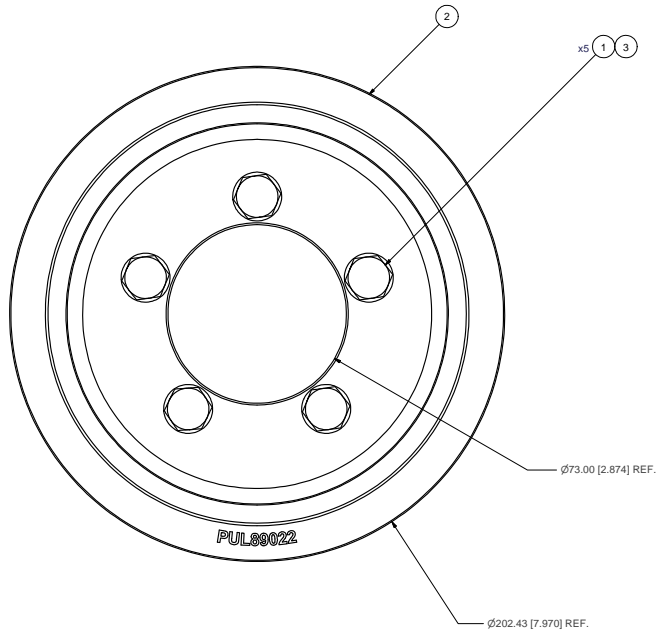
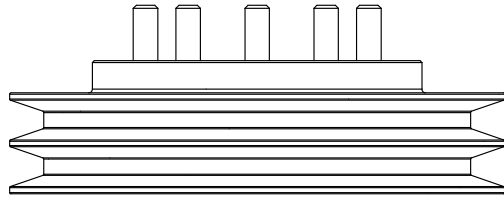

ISOMETRIC VIEW

- NOTES:**
- 1) USE SERVICABLE THREADLOCKER ON ALL FASTENERS TO ENGINE COMPONENTS AND TORQUE ALL BOLTS TO S.A.E. SPECIFICATIONS.
  - 2) SEE "TRANSARCTIC A/C COMPRESSOR MOUNT INSTALLATION DISCLAIMER".
  - 3) WT:≈ 11.56 LBS

ITEM	QTY	U/M	PART NUMBER	DESCRIPTION
3	5	EACH	WFA10000	WASHER, FLAT, 10mm, 8.8, PLT
2	1	EACH	PUL89022	PULLEY, CRANK, ISL, 8.9L, 2B/X, 8", '13
1	5	EACH	BTCT0050	BOLT, HEX, 10 x 1.5 x 50mm, 10.9, PLT

**BILL OF MATERIALS**

RELEASED TO PRODUCTION	10/15/2013	JRB	
REVISION	DESCRIPTION	DATE	BY
			James Stewart
			Ron Ingram
			Dale Mason

DRAWN	10/15/2013	<b>TRANSARCTIC INC.</b>
CHECKED	10/15/2013	
TITLE		
KIT, PULLEY, ISL, 8.9L, 2B/X, '13		
SIZE	DWG NO	REV
D	KPC89022	0
SCALE	1:1	SHEET 1 OF 1

THIS DRAWING CONTAINS PROPRIETARY CONFIDENTIAL INFORMATION OWNED BY TRANSARCTIC CANADA INC. THE DOCUMENT AND THE INFORMATION IN IT ARE NOT TO BE USED, DISCLOSED OR REPRODUCED WITHOUT EXPRESS WRITTEN PERMISSION OF THE COMPANY.

UNSPECIFIED TOLERANCES: ALL DIMS IN MM  
 ONE DECIMAL PLACE (X.0) ± 0.10 (± 0.004)  
 TWO DECIMAL PLACE (X.00) ± 0.02 (± 0.0008)  
 THREE DECIMAL PLACE (X.000) ± 0.002 (± 0.00008)  
 FRACTIONAL (X/16) ANGULAR ± 30'

THIRD ANGLE PROJECTION

DRAWING UNIT OF MEASURE: MM (INCH)

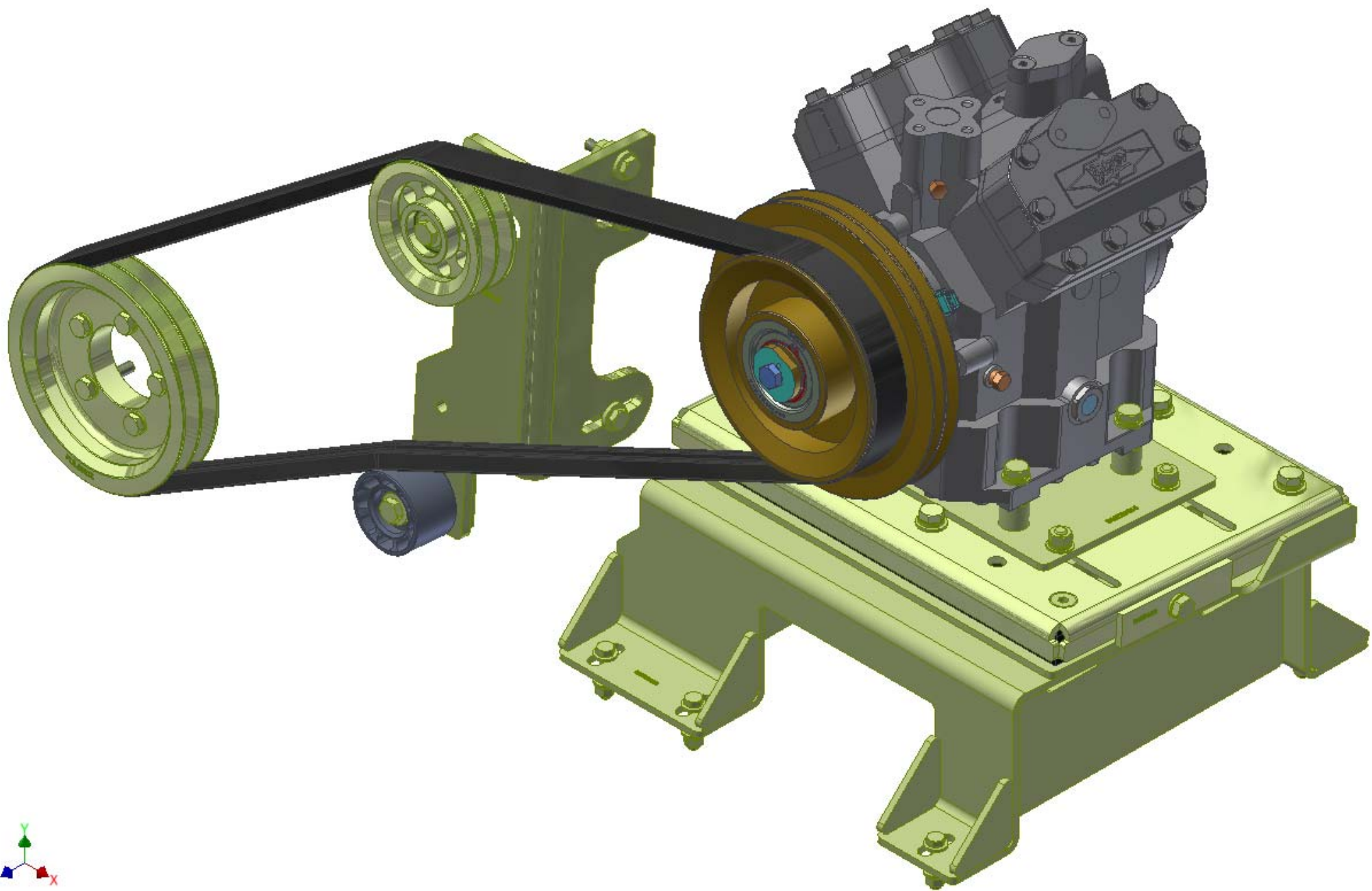

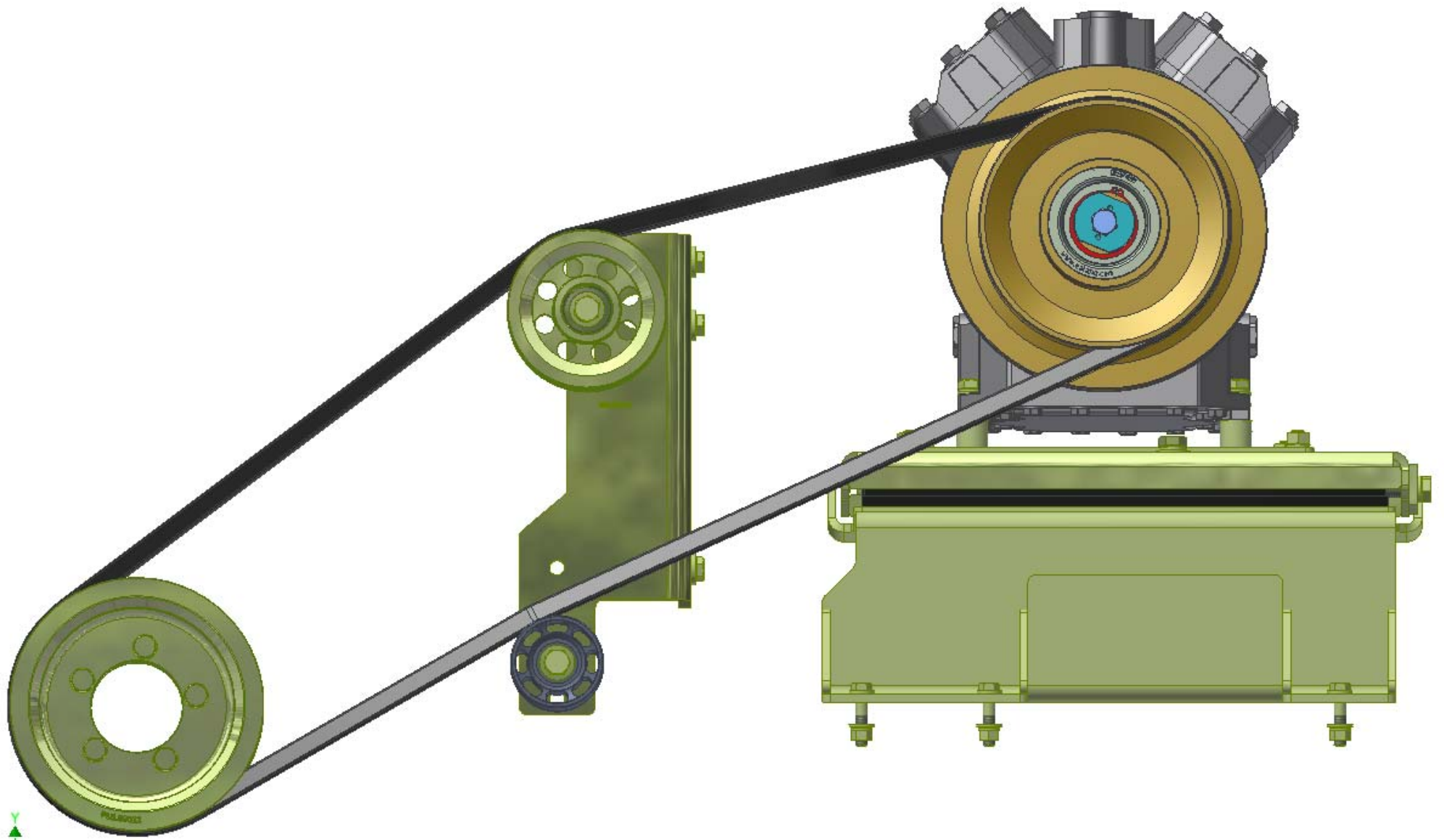

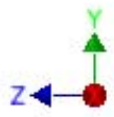
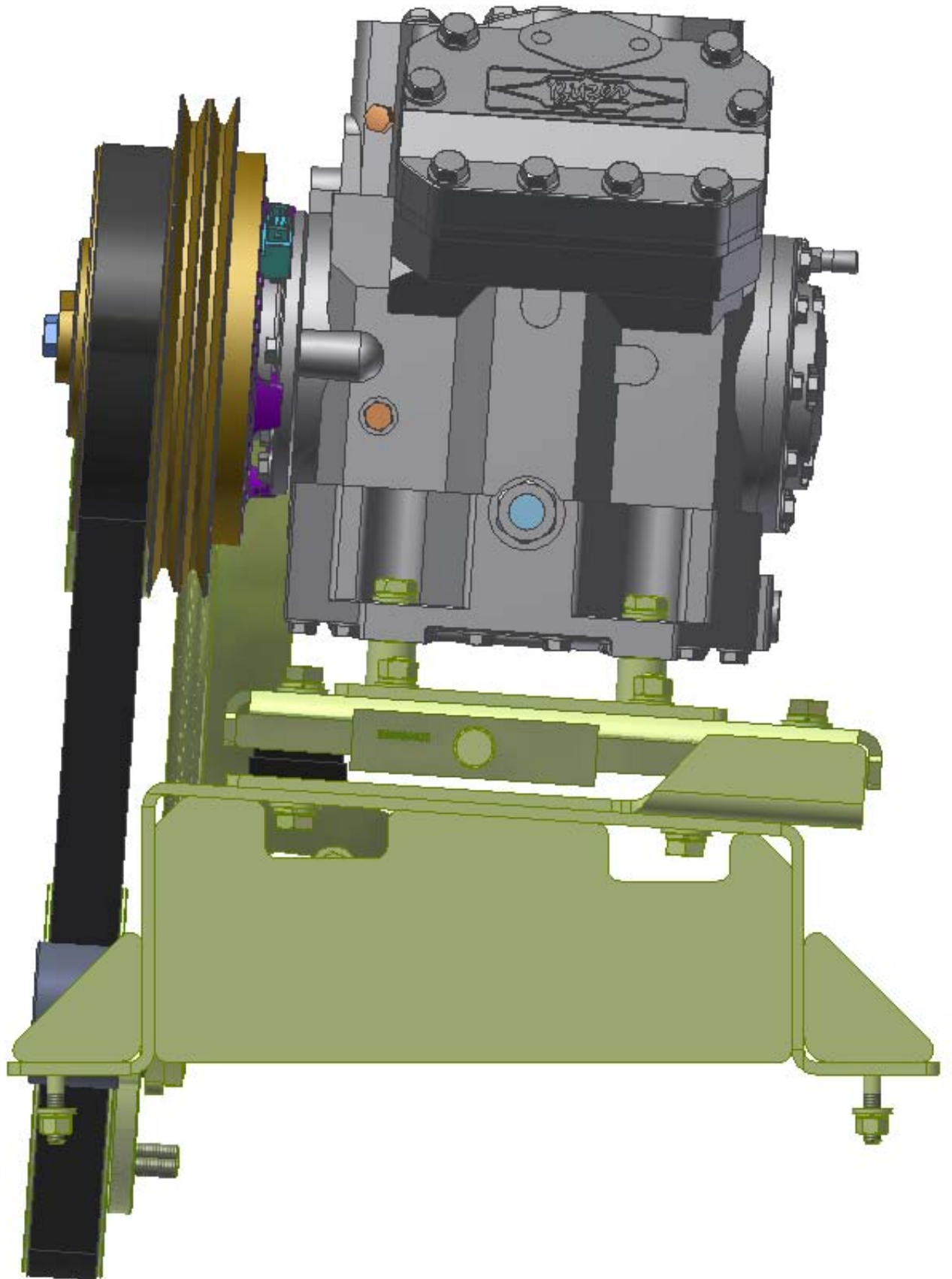

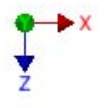
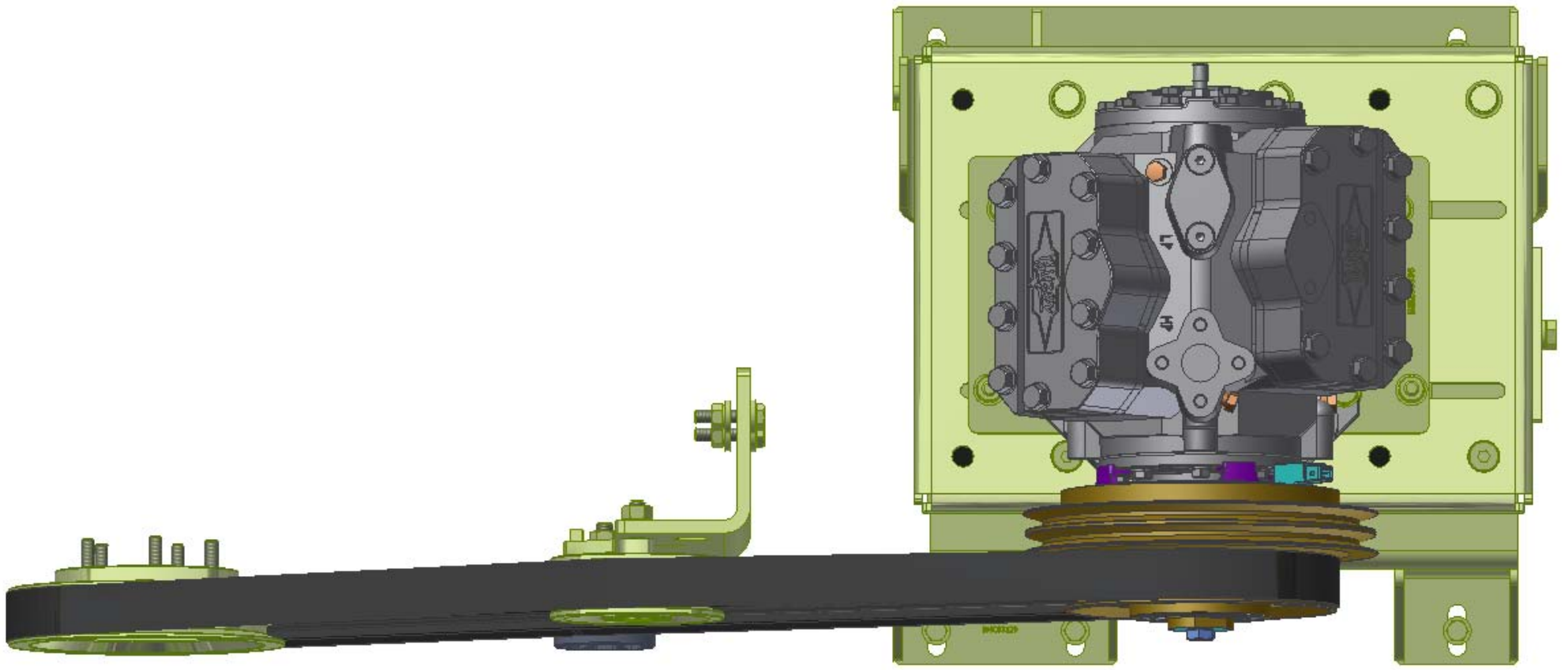

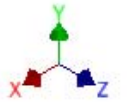
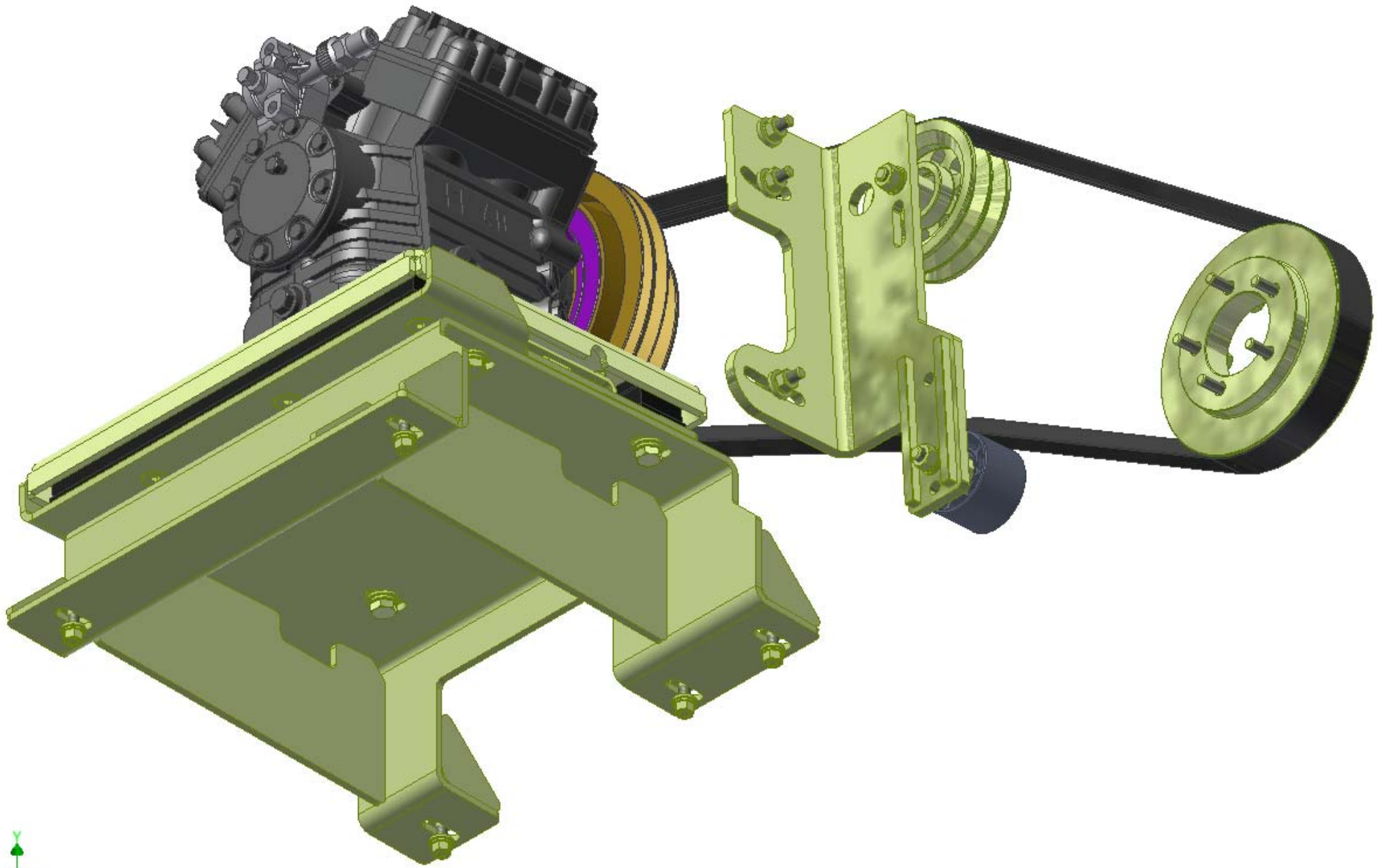



## **TransArctic A/C Compressor Mount Installation Disclaimer**

All compressor mounts should be installed by qualified and trained personnel using proper tools and equipment in safe working conditions following industry standard guidelines for motor vehicle service and repair.

The installer of any compressor mount purchased from TransArctic must undertake all responsibility of issues arising from that compressor bracket being installed on any vehicle. As well as insure that a **proper and sufficient ground** is established between the compressors' clutches and the vehicle's engine. Mount functionality, operation and durability can all be compromised by an incompetent installation.

Due to the many different situations, parameters and application criteria, which are beyond the compressor mount manufacturer's control, TransArctic does not warrant design, durability, or operational functionality of any compressor mount improperly installed by another party.

**With no implied guarantees it is the mount installer's strict responsibility to determine safety and functionality, of the compressor mount, at the time of installation.**

Please contact TransArctic with any issue arising from installation so we may better improve the product. If you have any reservations about the compressor mount integrity contact TransArctic immediately at 1-877-COLD-AIR.

**Mark OEM tensioner location**

**Install Kit**

**Check for Interferences**

**Check to ensure that the proper OEM tensioner orientation is maintained**

**Run engine with A/C system engaged for at least 10 minutes to run in belt**

**Check OEM tensioner orientation and adjust as required**

### **Responsabilidad limitada de TransArctic en la instalación del soporte del compresor**

Todos los soportes de los compresores deben ser instalados por personas calificadas y entrenadas, usando para ello los equipos y herramientas necesarios para esta labor en buenas condiciones y según las normas y guías para el servicio y/o reparación de motores de vehículos.

El instalador de los soportes comprados en TransArctic asume toda la responsabilidad de cualquier problema que surga en el soporte del compresor al vehículo; de igual manera es responsable que el cable a tierra sea conectado entre el embrague del compresor y el motor del vehículo.

Se advierte que el buen funcionamiento y la durabilidad del soporte pueden ser comprometidos por defectos en su instalación.

Debido a las diversas situaciones que se puedan presentar fuera del control del fabricante, TransArctic no garantiza el diseño, la durabilidad o el correcto funcionamiento de cualquier equipo inapropiadamente instalado por terceros.

**Esta sobreentendido que el Instalador del montaje del compresor es estrictamente responsable de la seguridad y funcionamiento del equipo en el momento de la instalación.**

Si tuviera algún problema o duda acerca de la instalación del soporte del compresor pongase en contacto inmediatamente con TransArctic al teléfono 1-877-COLD-AIR de modo que podamos mejorar nuestro producto.

**Note la ubicación del medidor de tensión OEM**

**Instale el equipo**

**Controlar si hay interferencias.**

**Asegurese que el medidor de tensión mantenga la orientación justa.**

**Encienda el motor por lo menos 10 minutos con el sistema A/C enganchado para que la correa corra**

**Controle la orientación justa del medidor de tensión y ajuste a las condiciones requeridas del fabricante**