



PARTS AND SERVICE MANUAL

For KPP15055

DIESEL POWER PACK

INDEPENDENT TRANSIT COMPRESSOR SYSTEM

TABLE OF CONTENTS

	Summary.....	ii
1.0	Transarctic KPP15055 Drawings and Bill of Material	
1.1	KPP15055- Power Pack, Main Assembly.....	4
1.2	KPP01510- Engine Assembly Kit.....	5
1.2a	ENG30015- Engine Modified.....	6
1.3	KPP01520- Radiator Assembly Kit.....	7
1.4	KPP01530- Electrical Assembly Kit.....	8
1.5	KPP01540- Power Pack Install Kit.....	9
1.6	KPP01560- Fuel Assembly Kit.....	10
2.0	VDO TACHOMETER	
2.1	Installation.....	11
2.2	Technical Service Bulletin (TB-333 001).....	13
3.0	LOFA MC704 Engine Controller Panel	
3.1	Overview.....	14
3.2	Wiring Schematic.....	16
3.3	Operation And Troubleshooting.....	20
4.0	Leece Neville 24V/ 150A (8SC3200V) Alternator	
4.1	Overview.....	36
4.2	Technical Service Bulletin (TSB-1031).....	40
4.3	Technical Service Bulletin (TSB-1105).....	41
5.0	Valeo Compressor (Z0015838A)	
5.1	Schematic Drawing.....	51
5.2	Service Manual.....	55
6.0	CAT 1.5L Diesel Engine	
6.1	Parts Manual.....	111
6.2	Operation Manual.....	306

Summary

Transarctic KPP15055 Diesel Power Pack

Caterpillar C1.5 EPA Tier 4 Final

- Producing 40.2 bhp (30 bkW) and 83 lb/ft (112Nm) of torque at 1800 rpm
- Meets existing Tier 3/Stage IIIA emission standards for North America and Europe

FEATURES

- Operation Independent of Vehicle - Only Needs Fuel from Fuel Tank
- Caterpillar – Reliability, Service and Warranty
- Dash Mounted Electronic Drivers Control with Hour Meter and Fail-Safe
- Remote Operation from Drivers Seat
- Improved Service Accessibility
- Service Hatch for Routine Maintenance
- Removable from bus for Specialized Maintenance
- Low Profile Design (25" High)

COMPONENTS

- VDO Tachometer
- LOFA MC704 Engine Controller Panel
- Leece Neville 24V/ 150A (8SC3200V) Alternator
- Valeo Compressor (Z0015838A)
- CAT 1.5L Diesel Engine

NOT AVAILABLE

AT THIS TIME

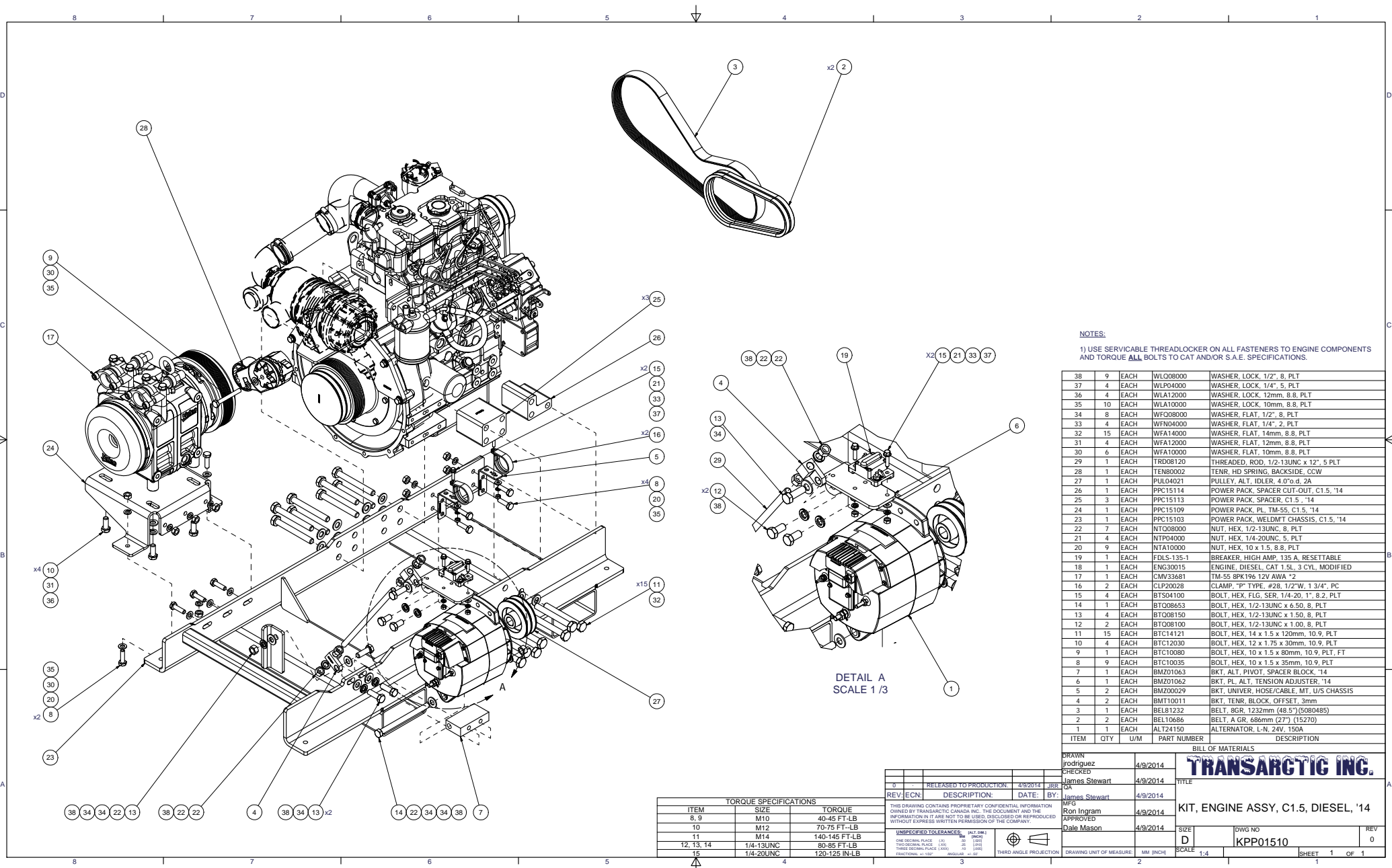

NOTES:
 1) USE SERVICABLE THREADLOCKER ON ALL FASTENERS TO ENGINE COMPONENTS AND TORQUE ALL BOLTS TO CAT AND/OR S.A.E. SPECIFICATIONS.

38	9	EACH	WLO80800	WASHER, LOCK, 1/2", 8, PLT
37	4	EACH	WLP04000	WASHER, LOCK, 1/4", 5, PLT
36	4	EACH	WLA12000	WASHER, LOCK, 12mm, 8.8, PLT
35	10	EACH	WLA10000	WASHER, LOCK, 10mm, 8.8, PLT
34	8	EACH	WFO80800	WASHER, FLAT, 1/2", 8, PLT
33	4	EACH	WFO4000	WASHER, FLAT, 1/4", 2, PLT
32	15	EACH	WFA14000	WASHER, FLAT, 14mm, 8.8, PLT
31	4	EACH	WFA12000	WASHER, FLAT, 12mm, 8.8, PLT
30	6	EACH	WFA10000	WASHER, FLAT, 10mm, 8.8, PLT
29	1	EACH	TRO08130	THREADED, ROD, 1/2-13UNC x 12", 5 PLT
28	1	EACH	TEN00002	TENR, HD SPRING, BACKSIDE, CCW
27	1	EACH	PUL04021	PULLEY, ALT, IDLER, 4.0"o.d, 28
26	1	EACH	PPC15114	POWER PACK, SPACER CUT-OUT, C1.5, '14
25	3	EACH	PPC15113	POWER PACK, SPACER, C1.5, '14
24	1	EACH	PPC15109	POWER PACK, PL, TM-55, C1.5, '14
23	1	EACH	PPC15103	POWER PACK, WELDMT CHASSIS, C1.5, '14
22	7	EACH	NT08000	NUT, HEX, 1/2-13UNC, 8, PLT
21	4	EACH	NT04000	NUT, HEX, 1/4-20UNC, 5, PLT
20	9	EACH	NTA10000	NUT, HEX, 10 x 1.5, 8.8, PLT
19	1	EACH	FDS-135-1	BREAKER, HIGH AMP, 135 A, RESETTABLE
18	1	EACH	ENG30015	ENGINE, DIESEL, CAT 1.5L, 3 CYL, MODIFIED
17	1	EACH	CMV33681	TM-55 8PK196 12V AWA *2
16	2	EACH	CLP20028	CLAMP, "P" TYPE, #28, 1/2"W, 1 3/4", PC
15	4	EACH	BTS04100	BOLT, HEX, FLG, SER, 1/4-20, 1", 8.2, PLT
14	1	EACH	BTO08653	BOLT, HEX, 1/2-13UNC x 6.50, 8, PLT
13	4	EACH	BTO08150	BOLT, HEX, 1/2-13UNC x 1.50, 8, PLT
12	2	EACH	BTO08100	BOLT, HEX, 1/2-13UNC x 1.00, 8, PLT
11	15	EACH	BTC14121	BOLT, HEX, 14 x 1.5 x 120mm, 10.9, PLT
10	4	EACH	BTC12030	BOLT, HEX, 12 x 1.75 x 30mm, 10.9, PLT
9	1	EACH	BTC10080	BOLT, HEX, 10 x 1.5 x 80mm, 10.9, PLT, FT
8	9	EACH	BTC10035	BOLT, HEX, 10 x 1.5 x 35mm, 10.9, PLT
7	1	EACH	BMZ01063	BKT, ALT, PIVOT, SPACER BLOCK, '14
6	1	EACH	BMZ01062	BKT, PL, ALT, TENSION ADJUSTER, '14
5	2	EACH	BMZ00029	BKT, UNIVER, HOSE/CABLE, MT, U/S CHASSIS
4	2	EACH	BMT10011	BKT, TENR, BLOCK, OFFSET, 3mm
3	1	EACH	BEL1232	BELT, 8GR, 1232mm (48.5") (5080485)
2	2	EACH	BEL10686	BELT, A CR, 686mm (27") (15270)
1	1	EACH	ALT24150	ALTERNATOR, L-N, 24V, 150A

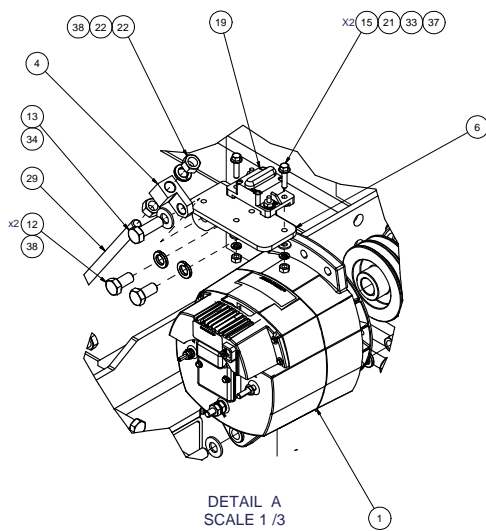

ITEM	SIZE	TORQUE
8, 9	M10	40-45 FT-LB
10	M12	70-75 FT-LB
11	M14	140-145 FT-LB
12, 13, 14	1/4-13UNC	80-85 FT-LB
15	1/4-20UNC	120-125 IN-LB

UNSPECIFIED TOLERANCES: ANGULAR ±.01°
 ONE DECIMAL PLACE (X.0) ±.005
 TWO DECIMAL PLACE (X.00) ±.002
 THREE DECIMAL PLACE (X.000) ±.001

THIRD ANGLE PROJECTION

TRANSARGTIG INC.

TITLE: KIT, ENGINE ASSY, C1.5, DIESEL, '14

DATE: 4/9/2014

BY: James Stewart

APPROVED: Ron Ingram

SCALE: 1:4

DWG NO: KPP01510

REV: 0

SHEET 1 OF 1

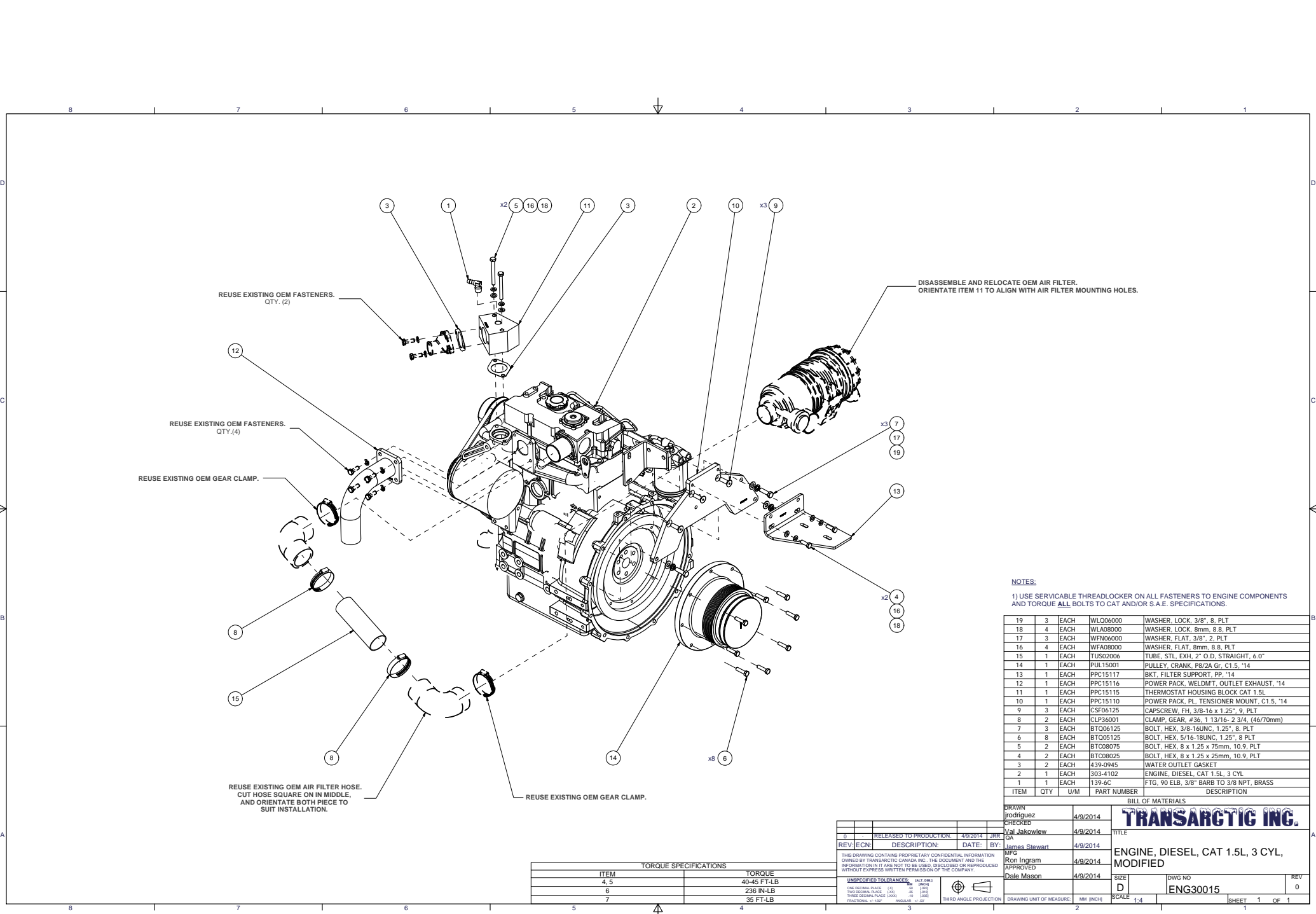

NOTES:
 1) USE SERVICABLE THREADLOCKER ON ALL FASTENERS TO ENGINE COMPONENTS AND TORQUE **ALL** BOLTS TO CAT AND/OR S.A.E. SPECIFICATIONS.

ITEM	QTY	U/M	PART NUMBER	DESCRIPTION
19	3	EACH	WL006000	WASHER, LOCK, 3/8", 8, PLT
18	4	EACH	WL080000	WASHER, LOCK, 8mm, 8, 8, PLT
17	3	EACH	WFO06000	WASHER, FLAT, 3/8", 2, PLT
16	4	EACH	WFA08000	WASHER, FLAT, 8mm, 8, 8, PLT
15	1	EACH	TUS02006	TUBE, STL, EXH, 2" O.D, STRAIGHT, 6.0"
14	1	EACH	PUL15001	PULLEY, CRANK, P8/2A Gr, C1.5, '14
13	1	EACH	PPC15117	BKT, FILTER SUPPORT, PP, '14
12	1	EACH	PPC15116	POWER PACK, WELDMT, OUTLET EXHAUST, '14
11	1	EACH	PPC15115	THERMOSTAT HOUSING BLOCK CAT 1.5L
10	1	EACH	PPC15110	POWER PACK, PL, TENSIONER MOUNT, C1.5, '14
9	3	EACH	CSF06125	CAPSCREW, FH, 3/8-16 x 1.25", 9, PLT
8	2	EACH	CLP36001	CLAMP, GEAR, #36, 1 13/16- 2 3/4, (46/70mm)
7	3	EACH	BTQ06125	BOLT, HEX, 3/8-16UNC, 1.25", 8, PLT
6	8	EACH	BTQ05125	BOLT, HEX, 5/16-18UNC, 1.25", 8, PLT
5	2	EACH	BTC08075	BOLT, HEX, 8 x 1.25 x 75mm, 10.9, PLT
4	2	EACH	BTC08025	BOLT, HEX, 8 x 1.25 x 25mm, 10.9, PLT
3	2	EACH	439-0945	WATER OUTLET GASKET
2	1	EACH	303-1102	ENGINE, DIESEL, CAT 1.5L, 3 CYL
1	1	EACH	139-4C	FTG, 90 LB, 3/8" BARB TO 3/8 NPT, BRASS

BILL OF MATERIALS

BROWN	4/9/2014
Jrodriquez	
CHECKED	
Vaj Jakowlew	4/9/2014
DATE	
Jungus Stewart	4/9/2014
BY	
Ron Ingram	4/9/2014
APPROVED	
Date Mason	4/9/2014

TRANSARGTIG INC.

TITLE: ENGINE, DIESEL, CAT 1.5L, 3 CYL, MODIFIED

SIZE: D DWG NO: ENG30015 REV: 0

SCALE: 1:4 SHEET 1 OF 1

TORQUE SPECIFICATIONS	
ITEM	TORQUE
4, 5	40-45 FT-LB
6	236 IN-LB
7	35 FT-LB

UNSPECIFIED TOLERANCES: ALL DIM. PER ASME Y14.5-2009

ONE DECIMAL PLACE (X.0) 10 (10:1)

TWO DECIMAL PLACE (X.00) 20 (20:1)

THREE DECIMAL PLACE (X.000) 30 (30:1)

FRACTIONAL (X.125) 16 (16:1)

ANGULAR (X.5) 10 (10:1)

THIRD ANGLE PROJECTION

DRAWING UNIT OF MEASURE: MM [INCH]

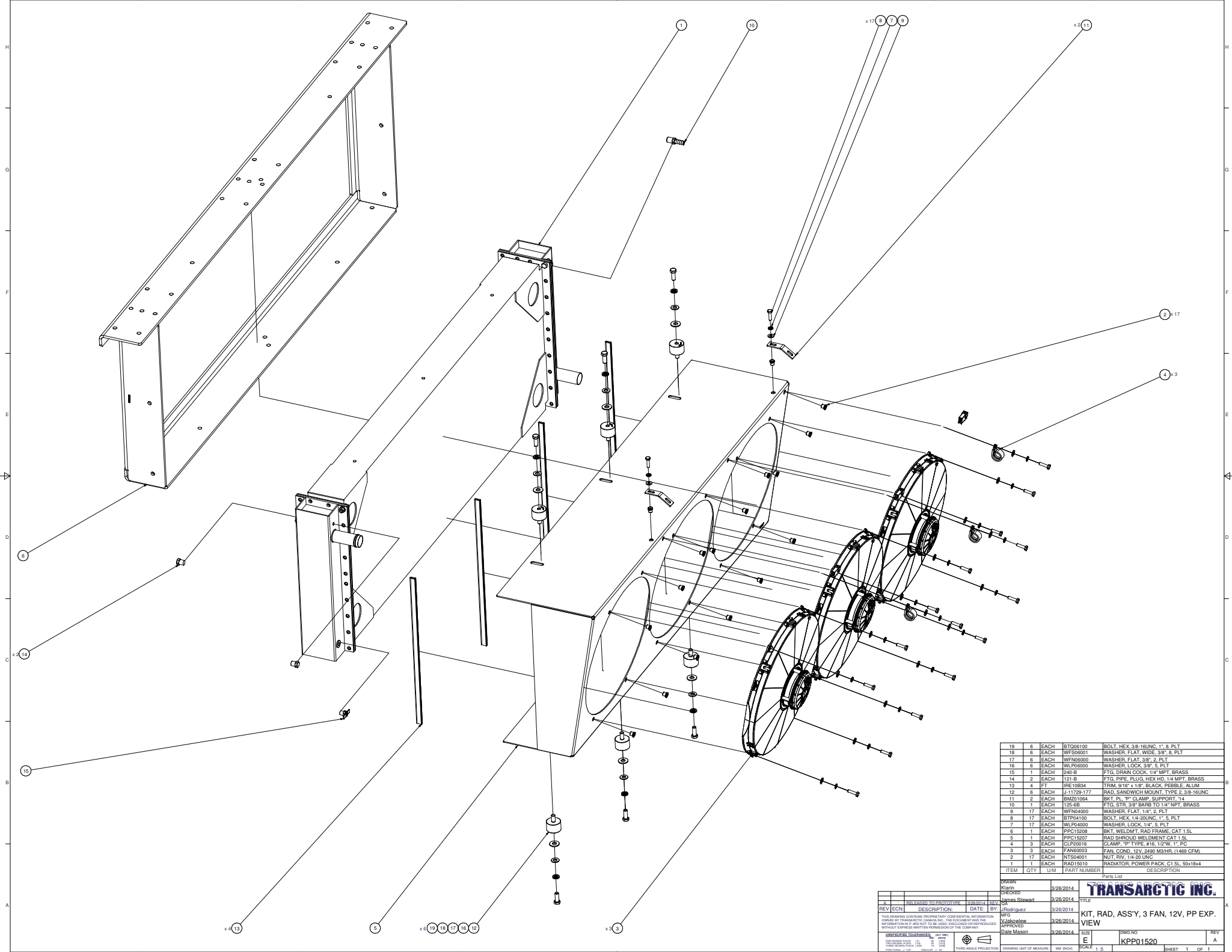

ITEM	QTY.	UOM.	PART NUMBER	DESCRIPTION
19	6	EACH	BT006100	BOLT, HEX, 3/8-16UNC, 1" & PLT
18	6	EACH	WFS06001	WASHER, FLAT, WIDE, 3/8", 8, PLT
17	6	EACH	WFM06000	WASHER, FLAT, WIDE, 3/8", 8, PLT
16	6	EACH	WLP04000	WASHER, LOCK, 3/8", 5, PLT
15	1	EACH	240-B	FTG. DRAIN COCK, 1/4" MPT, BRASS
14	2	EACH	121-B	FTG. PIPE, PLUG, HEX HD, 1/4 MPT, BRASS
13	4	FT	IRE 10834	TRIM, 9/16" x 7/8", BLACK, PEBBLE, ALUM
12	6	EACH	111229-177	RAD. SANDWICH MOUNT, TYPE 2, 3/8-16UNC
11	2	EACH	BM201064	BKT. PL. "P" CLAMP, SUPPORT, 1/4
10	1	EACH	125-68	FTG. STR. 3/8" BARB TO 1/4" NPT, BRASS
9	17	EACH	WFM04000	WASHER, FLAT, 1/4", 5, PLT
8	17	EACH	BT041000	BOLT, HEX, 1/4-20UNC, 1", 5, PLT
7	17	EACH	WLP04000	WASHER, LOCK, 1/4", 5, PLT
6	1	EACH	PPC15208	BKT. WELDMT, RAD FRAME, CAT 1.5L
5	1	EACH	PPC15207	RAD SHROULD WELDMENT CAT 1.5L
4	3	EACH	CLP20016	CLAMP, "P" TYPE, #16, 1/2"W, 1", PC
3	3	EACH	FAN03003	FAN, COND, 12V, 3400 RPM/HR, (1.469 CFM)
2	17	EACH	NTS04001	NUT, RIV, 1/4-20 UNC
1	1	EACH	RAD15010	RADIATOR, POWER PACK, G1.5L, 50x18x4

DRAWN: Kiarra
 CHECKED: Jeynes Stewart
 DATE: 3/26/2014
 BY: Jeynes Stewart
 DATE: 3/26/2014
 APPROVED: MFO
 DATE: 3/26/2014
 DATE: Mason
 DATE: 3/26/2014

TRANSARCTIC INC.
 KIT, RAD, ASS'Y, 3 FAN, 12V, PP EXP. VIEW
 DWG NO: KPP01520
 SCALE: 1:5
 SHEET: 1 OF 1

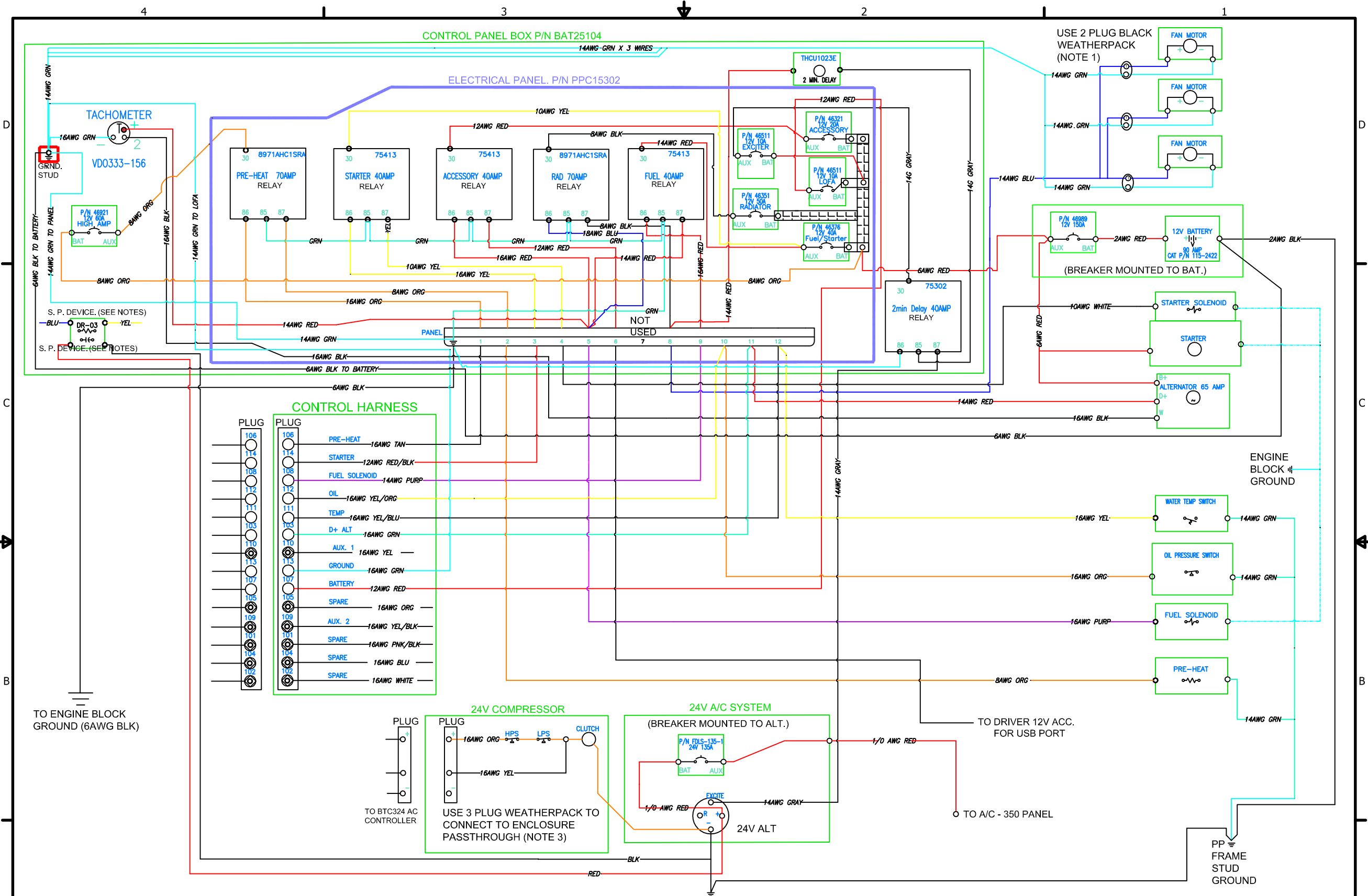

NOTES:
 1) COMPRESSOR WEATHER PACK. ON OTHER END USE 3/8" TERMINAL RING TO CONNECT TO JUNCTION STUD PASS-THROUGH ON ENCLOSURE PLATE.
 2) SURGE PROTECTION DEVICE TA. P/N SPD24003 LOCATED IN CONTROL PANEL BOX BLU & YEL WIRES NOT USED.

0	RELEASED TO PRODUCTION	5/13/2014	KEV
REV:ECN:	DESCRIPTION:	DATE:	BY:
THIS DRAWING CONTAINS PROPRIETARY CONFIDENTIAL INFORMATION OWNED BY TRANSARCTIC CANADA INC. THE DOCUMENT AND THE INFORMATION IN IT ARE NOT TO BE USED, DISCLOSED OR REPRODUCED WITHOUT EXPRESS WRITTEN PERMISSION OF THE COMPANY.			
UNSPECIFIED TOLERANCES:		[ALT. DIM.]	
ONE DECIMAL PLACE (X)	.50	[MM]	[INCH]
TWO DECIMAL PLACE (XX)	.25	[MM]	[INCH]
THREE DECIMAL PLACE (XXX)	.10	[MM]	[INCH]
FRACTIONAL (+/- 1/32")	ANGULAR	±.50	

DRAWN KLarin	3/06/2014
CHECKED JAMES STEWART	5/13/2014
QA James Stewart	5/13/2014
MFG JAMES STEWART	5/13/2014
APPROVED DALE MASON	3/06/2014
DRAWING UNIT OF MEASURE: MM [INCH]	

TRANSARCTIC INC.

TITLE
KPP15055 POWER PACK ELECTRICAL DIAGRAM

SIZE **C** DWG NO **KEL01530** REV **0**

SCALE SHEET **1** OF **1**

NOT AVAILABLE

AT THIS TIME

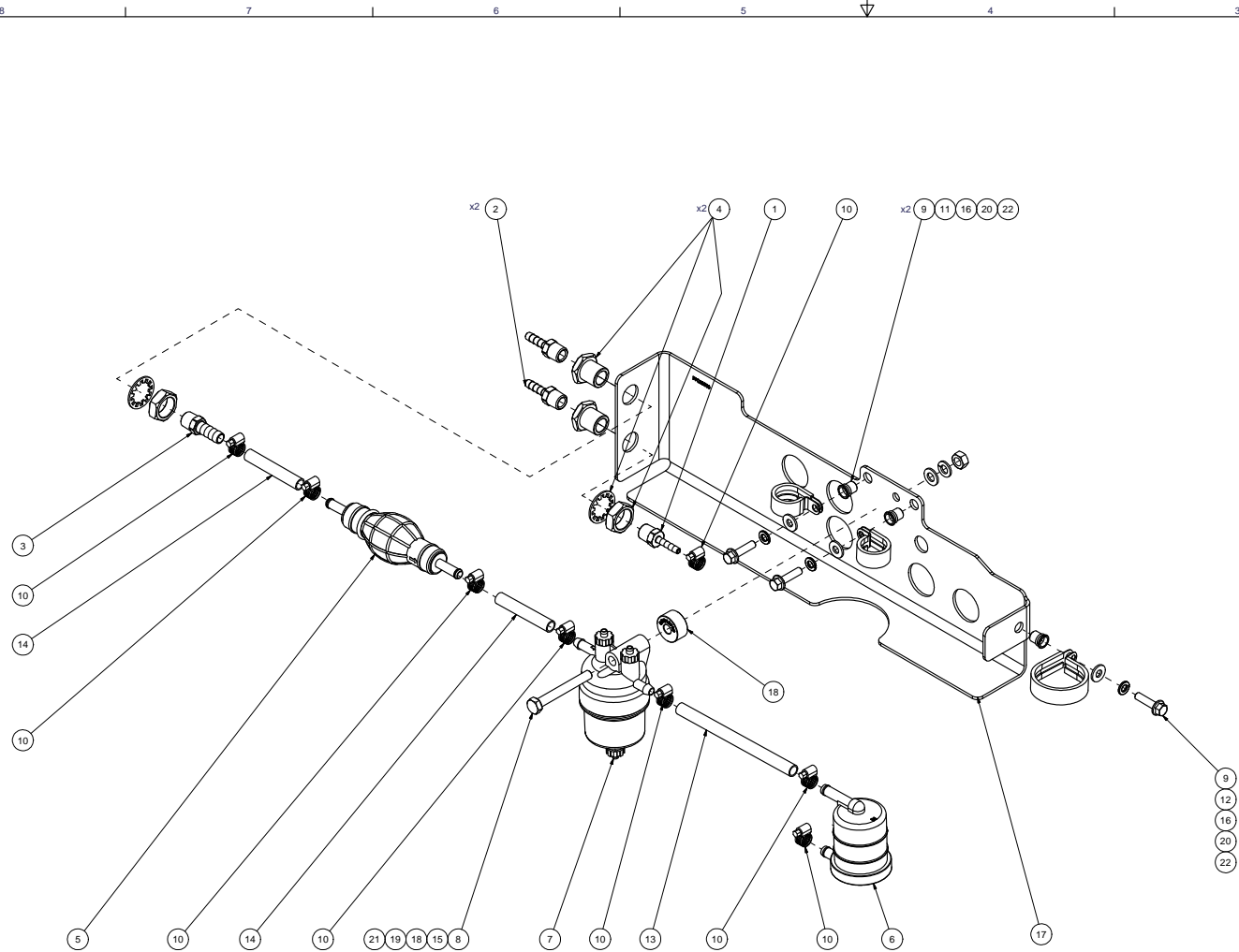

NOTES:

1) USE SERVICABLE THREADLOCKER ON ALL FASTENERS TO ENGINE COMPONENTS AND TORQUE ALL BOLTS TO CAT AND/OR S.A.E. SPECIFICATIONS.

ITEM	QTY	UM	PART NUMBER	DESCRIPTION
22	3	EACH	WLP04000	WASHER, LOCK, 1/4", 5, PLT
21	1	EACH	WLA08000	WASHER, LOCK, 8mm, 8.8, PLT
20	3	EACH	WFO04000	WASHER, FLAT, 1/4", 2, PLT
19	1	EACH	WFA08000	WASHER, FLAT, 8mm, 8.8, PLT
18	1	EACH	SCD12708	SPACER, COL. DRIL, 12.7mm x 25.40 x 8.331
17	1	EACH	PPC15600	BKT. FUEL SYSTEM KPP15055
16	3	EACH	NTS04001	NUT, RIV, 1/4-20 UNC
15	1	EACH	NTA08000	NUT, HEX, 8 x 1.25, 8.8 PLT
14	2	EACH	HOF03100	HOSE, FUEL, 5/16", DAYCO x 2.25"L
13	1	EACH	HOF03100	HOSE, FUEL, 5/16", DAYCO x 6.00"L
12	1	EACH	CLP20028	CLAMP, "P" TYPE, #28, 1/2"W, 1 3/4", PC
11	2	EACH	CLP20016	CLAMP, "P" TYPE, #16, 1/2"W, 1", PC
10	8	EACH	CLP06001	CLAMP, GEAR, #6, 3/8-3/4 (10-20mm), S
9	3	EACH	BTS04100	BOLT, HEX, FLG, SER, 1/4-20, 1", 8.2, PLT
8	1	EACH	BTC08065	BOLT, HEX, 8 x 1.25 x 65mm, 10.9, PLT
7	1	EACH	276-1804	CAT, C1.1, FILTER, WATER SEPARATOR
6	1	EACH	243-6411	COARSE OIL FILTER
5	1	EACH	197-8540	CAT, C1.1, PRIME BULB
4	2	EACH	1495-SB	FTG, TERMINAL BOLT, 1/4" FPT ENDS, BRASS
3	1	EACH	125-SB	FTG, STR, 3/16" BARB TO 1/4" MPT, BRASS
2	2	EACH	125-AB	FTG, STR, 1/4" BARB TO 1/4" MPT, BRASS
1	1	EACH	125-3B	FTG, STR, 3/16" BARB TO 1/4" MPT, BRASS

BILL OF MATERIALS

ITEM	QTY	UM	PART NUMBER	DESCRIPTION
22	3	EACH	WLP04000	WASHER, LOCK, 1/4", 5, PLT
21	1	EACH	WLA08000	WASHER, LOCK, 8mm, 8.8, PLT
20	3	EACH	WFO04000	WASHER, FLAT, 1/4", 2, PLT
19	1	EACH	WFA08000	WASHER, FLAT, 8mm, 8.8, PLT
18	1	EACH	SCD12708	SPACER, COL. DRIL, 12.7mm x 25.40 x 8.331
17	1	EACH	PPC15600	BKT. FUEL SYSTEM KPP15055
16	3	EACH	NTS04001	NUT, RIV, 1/4-20 UNC
15	1	EACH	NTA08000	NUT, HEX, 8 x 1.25, 8.8 PLT
14	2	EACH	HOF03100	HOSE, FUEL, 5/16", DAYCO x 2.25"L
13	1	EACH	HOF03100	HOSE, FUEL, 5/16", DAYCO x 6.00"L
12	1	EACH	CLP20028	CLAMP, "P" TYPE, #28, 1/2"W, 1 3/4", PC
11	2	EACH	CLP20016	CLAMP, "P" TYPE, #16, 1/2"W, 1", PC
10	8	EACH	CLP06001	CLAMP, GEAR, #6, 3/8-3/4 (10-20mm), S
9	3	EACH	BTS04100	BOLT, HEX, FLG, SER, 1/4-20, 1", 8.2, PLT
8	1	EACH	BTC08065	BOLT, HEX, 8 x 1.25 x 65mm, 10.9, PLT
7	1	EACH	276-1804	CAT, C1.1, FILTER, WATER SEPARATOR
6	1	EACH	243-6411	COARSE OIL FILTER
5	1	EACH	197-8540	CAT, C1.1, PRIME BULB
4	2	EACH	1495-SB	FTG, TERMINAL BOLT, 1/4" FPT ENDS, BRASS
3	1	EACH	125-SB	FTG, STR, 3/16" BARB TO 1/4" MPT, BRASS
2	2	EACH	125-AB	FTG, STR, 1/4" BARB TO 1/4" MPT, BRASS
1	1	EACH	125-3B	FTG, STR, 3/16" BARB TO 1/4" MPT, BRASS

DRAWN	Klarin	3/24/2014
CHECKED	James Stewart	3/24/2014
RELEASED TO PRODUCTION	JRR	3/24/2014
REVISION	DESCRIPTION	DATE
	Urodriguez	3/24/2014
	MFG	3/24/2014
	V.Jakowlew	3/24/2014
	APPROVED	
	Dale Mason	3/24/2014

UNSPECIFIED TOLERANCES:		ALL DIM.	±.005
ONE DECIMAL PLACE	(X)	±.010	
TWO DECIMAL PLACE	(XX)	±.002	
THREE DECIMAL PLACE	(XXX)	±.001	
FRACTIONAL	(1/16")	±.001	
ANGULAR		±.05	



DRAWING UNIT OF MEASURE:	MM [INCH]
SCALE:	1:2
DWG NO:	KPP01560
REV:	0
SHEET:	1 OF 1



BKT. FUEL SYSTEM, KPP15055, EXPLODED VIEW

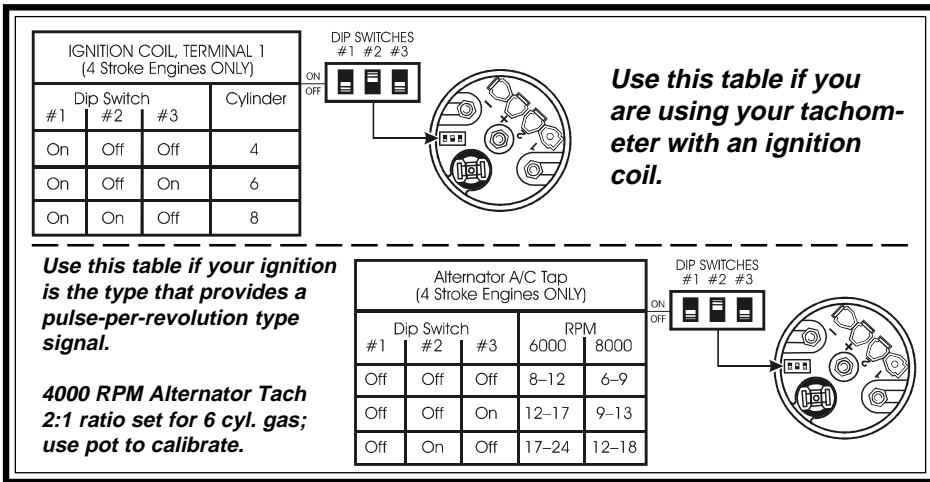

Diagram D

Tachometer configuration for use with ignition coil (top); alternator (bottom)

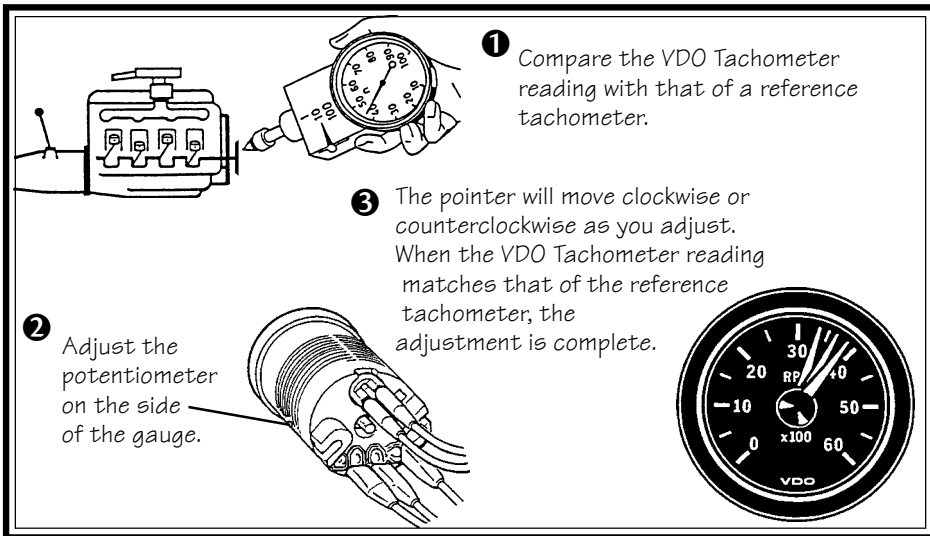

Diagram E

Fine tachometer adjustment needed when using a pulse-per-revolution signal

Merchandise warranted against defects in factory workmanship and materials for a period of 24 months after purchase. This warranty applies to the first retail purchaser and covers only those products exposed to normal use or service. Provisions of this warranty shall not apply to a VDO product used for a purpose for which it is not designed, or which has been altered in any way that would be detrimental to the performance or life of the product, or misapplication, misuse, negligence or accident. On any VDO part or VDO product found to be defective after examination by manufacturer, manufacturer will only repair or replace the merchandise through the original selling dealer. Manufacturer assumes no responsibility for diagnosis, removal and/or installation labor, loss of vehicle use, loss of time, inconvenience or any other consequential expenses. The warranties herein are in lieu of any other expressed or implied warranties, including any implied warranty of merchantability of fitness, and any other obligation on the part of manufacturer, or selling dealer.

(NOTE: This is a "Limited Warranty" as defined by the Magnuson-Moss Warranty Act of 1975.)

1 BEGIN HERE

CAUTION: Read these instructions thoroughly before making installation. Do not deviate from assembly or wiring instructions. Always disconnect battery ground before making any electrical connections. If in doubt, please contact your dealer or VDO Instruments at (800) 265-1818.

Tachometer Installation:

1. Select the location where you will mount the gauge, and cut a 2 1/16" hole as shown in Diagram A.
2. Slip the VDO Spin-Lok™ Mounting

CAUTION!!!

The bezel diameter is only a few millimeters larger than the gauge itself. With that in mind, measure and precisely mark the gauge location before cutting any holes!

Tools and Materials Needed For Installation:

- 16 Gauge stranded, insulated wire
- Non-insulated 1/4" spade connectors
- 2 1/16" hole saw
- Drill and drill bit set
- Half-round file
- Tape measure or ruler
- Small tools: wrench or nut driver, utility knife, pliers, etc.

Clamp over the back of the instrument. It's direction depends on the thickness of the panel (Diagram B). Tighten the clamp until the gauge can no longer be rotated by hand.

DO NOT OVERTIGHTEN.

Tachometer Wiring:

1. Run wires from the tachometer location to:
 - a) A +12 volt power terminal. (This positive power source **MUST BE SWITCHED**, and should be protected with a fuse);
 - b) the light switch (also after the fuse in the fuse box);
 - c) a good ground location;

[text continues at #2] ➔

Parts List		
Item	Description	Quantity
1.	Tachometer (2 1/16" [52 mm] diameter)	1
2.	Lamp Socket (Push in, wedge-type)	1
3.	Light Bulb (12-volt / G.E. #158 or equivalent)	1
4.	VDO Spin-Lok™ Clamp	1
5.	Installation Instructions	1



Tachometer Installation Instructions

Instruction Sheet #0 515 012 044
Rev. 10/09

INSTRUCTIONS FOR THE INSTALLATION OF THE TACHOMETER ARE CONTAINED HEREIN. USE IS RESTRICTED TO 12-VOLT NEGATIVE GROUND ELECTRICAL SYSTEMS. LIGHT BULB, IF SUPPLIED, IS 12 VOLT.

To Begin, go to #1

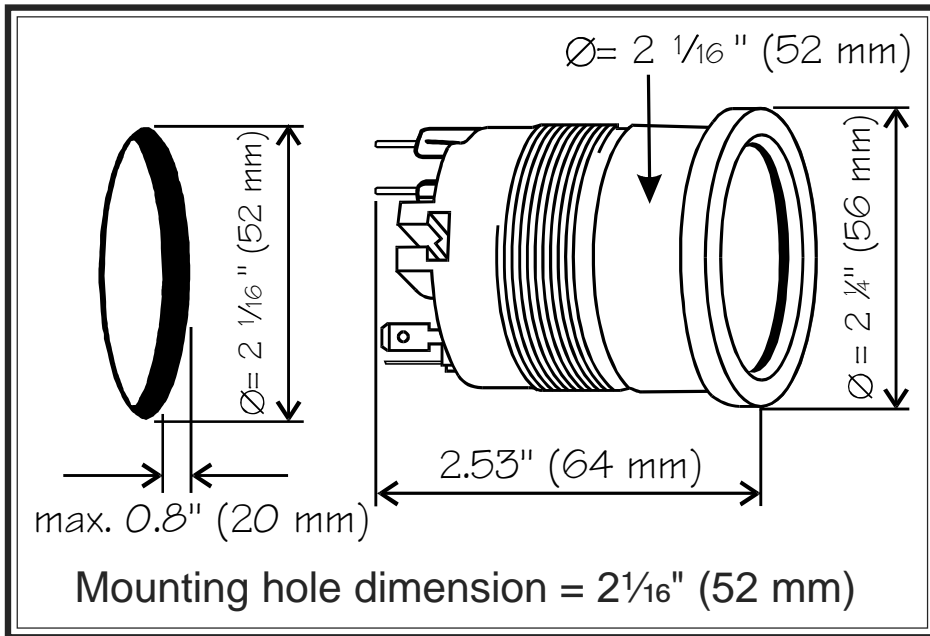

Diagram A
Gauge dimensions

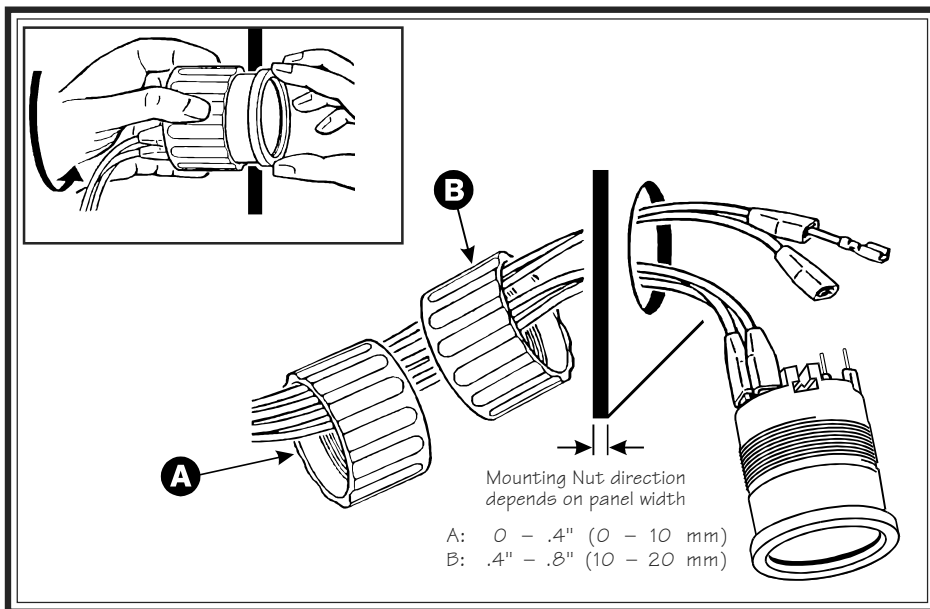

Diagram B
Proper mounting using VDO's Spin-Lok™ Mounting Clamp

2 CONTINUE HERE

d) the location of the signal source (alternator, coil or other ignition signal source).

2. Connect the wiring to the appropriate tachometer terminals as shown in Diagram C.

Configuring the Tachometer:

Before your VDO Tachometer will function properly with your engine, you will need to configure it as shown in Diagram D.

The table at the top of Diagram D shows how to set the DIP switches for use with an ignition coil; the table at the bottom shows how to set the DIP switches when using the tachometer with an alternator.

When using the VDO Tachometer with

another type of ignition system, determine the number of pulses per revolution the ignition signal provides, and set the DIP switches as shown in the bottom table.

Adjusting the Tachometer Pointer:

Use of the VDO Tachometer with an alternator or other type of ignition that provides a signal in pulses per revolution may require calibration of the pointer.

This can be done as show in Diagram E. Please note that this calibration is designed to adjust the reading between 30% and 100% of the RPM range.

At this point, the installation and wiring of your new VDO Tachometer is complete. Turn on the ignition and the lights in the car and check to see that the instrument and light work properly. If they don't, re-check your wiring, referring to the wiring description in Diagram C.

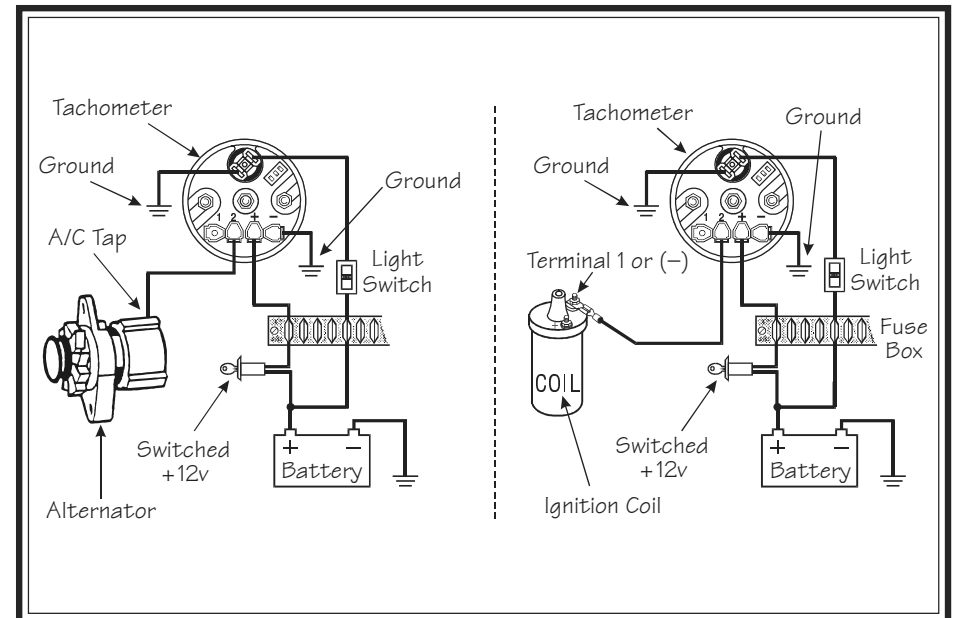

Diagram C
Tachometer wiring with Alternator AC Tap (left); and with Ignition Coil (right)

Product: Tachometer	Description ERRATIC OPERATION	Date Aug 03
Type: Electrical		Issue 1

To Reduce or Eliminate Erratic Operation in Tachometers

1. Purchase diode #1N4005 from your local electronics store.
2. Cut both ends of the diode so each is approx. 3/ 4" long.
3. Crimp a 1/ 4" female spade connector on the end of the diode with the silver band.
4. Crimp a butt-splice connector on the other end of the diode.
5. Crimp the opposite end of the butt-splice connector to the wire connected to ignition signal source.
6. Connect 1/ 4" female spade connector used in step # 3 above to terminal # 4 on the back of the tachometer.
7. Connect a ground (-) wire to terminal # 3.
8. Connect a switched 12-volt power wire to terminal # 2.
9. Set switches for the appropriate number of cylinders.

MC704 SERIES MICRO CONTROL PANEL

FOR MECHANICALLY GOVERNED ENGINES

The LOFA MC704 Series is a compact micro panel that controls, monitors and protects mechanically governed diesel engines.

MC704 FEATURES

- Rugged powder-coated aluminum housing
- Automatic shutdown bypass during starting
- Hour meter (on MC704HP)
- Microprocessor-based control designed with high power semiconductors
- First-Fault Diagnostic (FFD) LED pinpoints initial failure
 - OK/Preheat
 - Alternator charge failure
 - Low oil pressure
 - High coolant temperature
 - AUX switch
- Thru-panel or threaded inserts mounting
- Reverse polarity protection
- Heavy-duty IP64 key switch with booted key
- Key switch features mechanical lock-out to prevent re-start attempts when engine is running
- 12" connection pigtail terminating at a Delphi GT connector



MC704 HP Micro Panel With Hour Meter



MC704 LCP Micro Panel Without Hour Meter

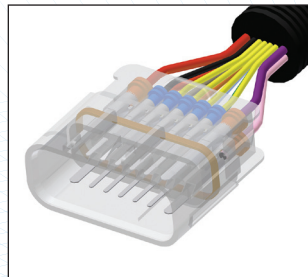
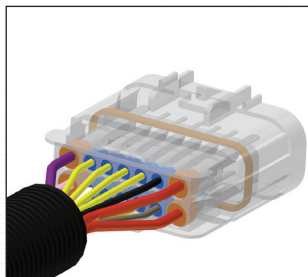

Delphi GT weather-proof connector on standard 12" wiring harness.
Other electrical connections available on request.

LOFA™

INDUSTRIES INC.

250 Hembree Park Drive, Suite 122

Roswell GA 30076

Phone: 770 569 9828

Fax: 770 569 9829

www.LOFA.net

Advanced Engine Control Technology

MC704 OPTIONS

- Plug-and-play harnesses
- Flip-down key switch cover
- Alarm or preheat control output (active high)

MC704 WARRANTY

- 2 Year Limited Warranty

MC704 DIMENSIONS

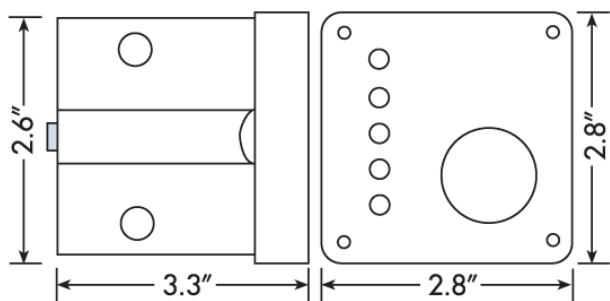

MC704 SPECIFICATIONS

Voltage - System Nominal	10-28 VDC
Operating Temperature	-20F to 185F (-30C to 85C)
Reverse Polarity Protection	Yes
Starter Relay	Suggested
Solid State I/O:	
Fuel Solenoid	20A
Switched Battery	15A
Starter	50A@1sec; 12A
Alarm Output	3.5A



Advanced Engine Control Technology

MC-704 SERIES SCHEMATIC WITHOUT PREHEAT

MC 704 - LC / H

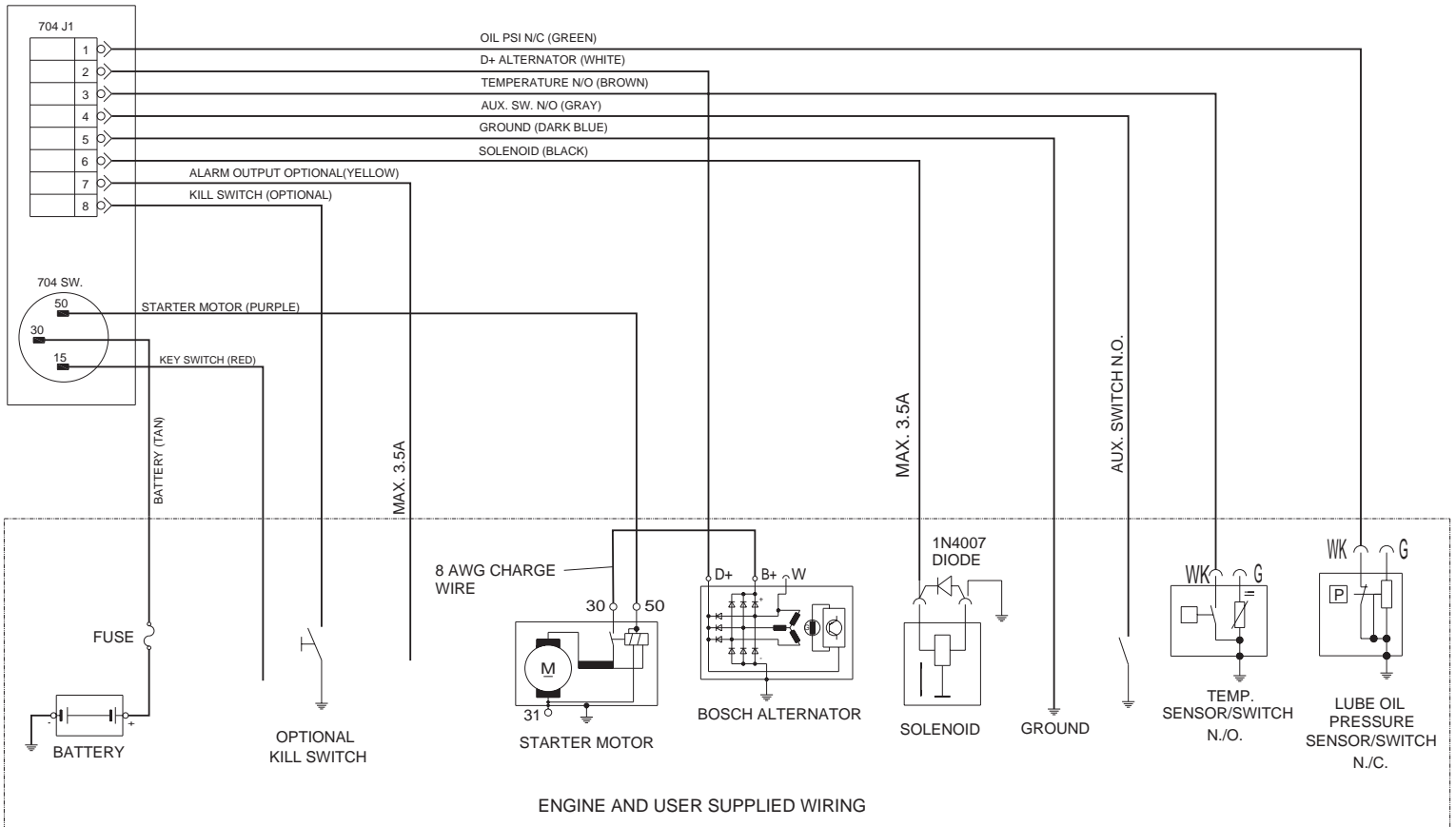

REDUCING VOLTAGE SPIKES

High Voltage spikes up to 1000V or more can occur momentarily when a relay or solenoid is switched off. Relay contacts, electronics, etc. can be damaged or malfunctions can occur if these spikes reach the electrical network without suppression. A **1N4007** diode should be used when using any of LOFA's products. Please install this diode as close as possible to the solenoid. Please note installing the diode incorrectly or reversing the polarity of the battery will damage the diode.

BLACK 16 AWG TO 704 #6

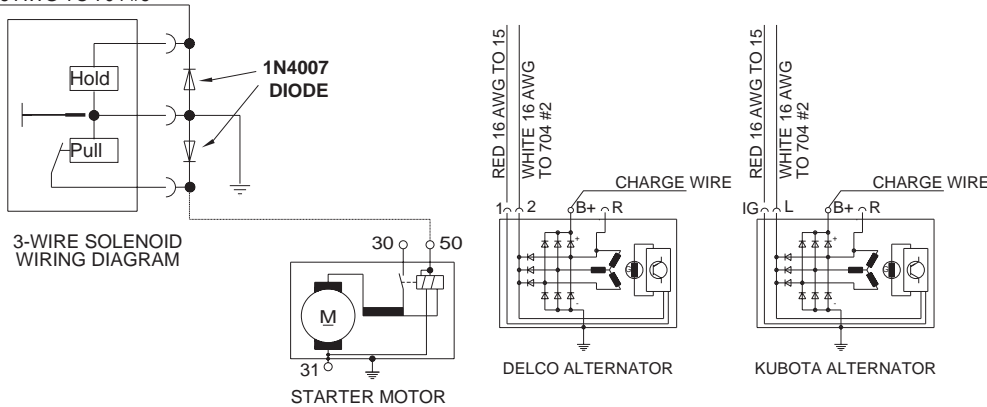

POS.	0	I	II	CURRENT
30 - 83	█			2 A
30 - 75		█		20 A
30 - 15		█	█	25 A
30 - 50		█	█	50 A 12 A



PHONE 770 569 9828 FAX 770 569 9829 www.LOFA.net

©2002 LOFA Industries, Inc. LOFA Industries, Inc. is constantly striving to improve its products and must therefore reserve the right to change designs, materials, specifications and prices without notice. Printed in the USA. 9/03

250 Hembree Park Drive Suite 122 Roswell GA 30076

MC-704 SERIES SCHEMATIC WITH PREHEAT

MC 704 - LC / H

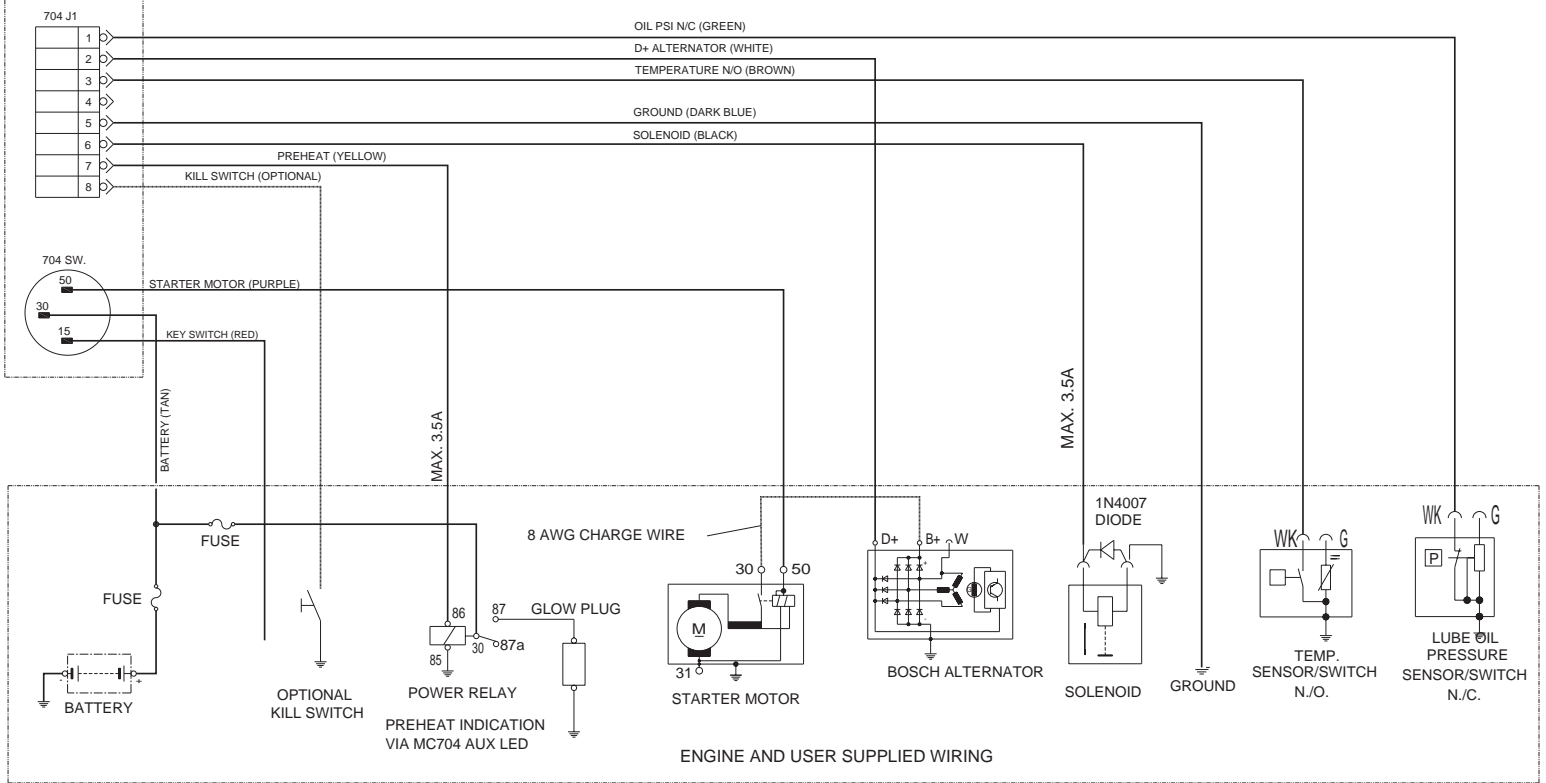

REDUCING VOLTAGE SPIKES

High Voltage spikes up to 1000V or more can occur momentarily when a relay or solenoid is switched off. Relay contacts, electronics, etc. can be damaged or malfunctions can occur if these spikes reach the electrical network without suppression. A **1N4007** diode should be used when using any of LOFA's products. Please install this diode as close as possible to the solenoid. Please note installing the diode incorrectly or reversing the polarity of the battery will damage the diode.

BLACK 16 AWG TO 704 #6

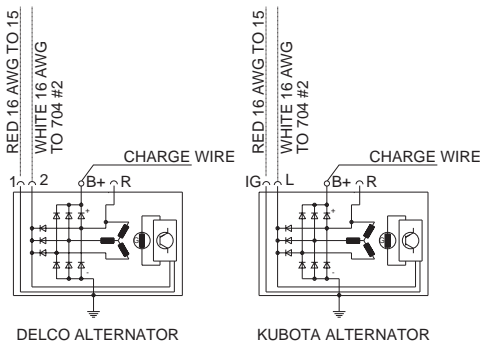
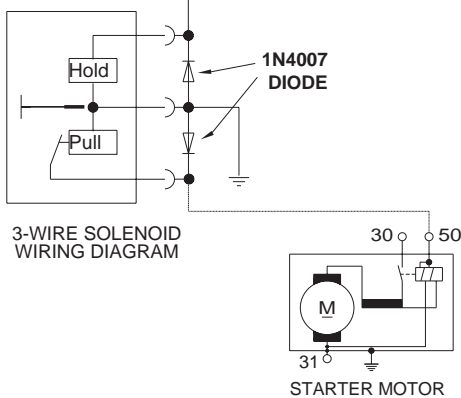

KEY SWITCH ELECTRICAL DIAGRAM

POS.	0	I	II	CURRENT
30 - 83	█			2 A
30 - 75		█		20 A
30 - 15		█	█	25 A
30 - 50		█	█	50 A 12 A



PHONE 770 569 9828 FAX 770 569 9829 www.LOFA.net

©2002 LOFA Industries, Inc. LOFA Industries, Inc. is constantly striving to improve its products and must therefore reserve the right to change designs, materials, specifications and prices without notice. Printed in the USA. 9/03

250 Hembree Park Drive Suite 122 Roswell GA 30076

MC-704 SERIES SCHEMATIC WITH PREHEAT AND AUXILIARY SHUTDOWN

MC 704 - LC / H

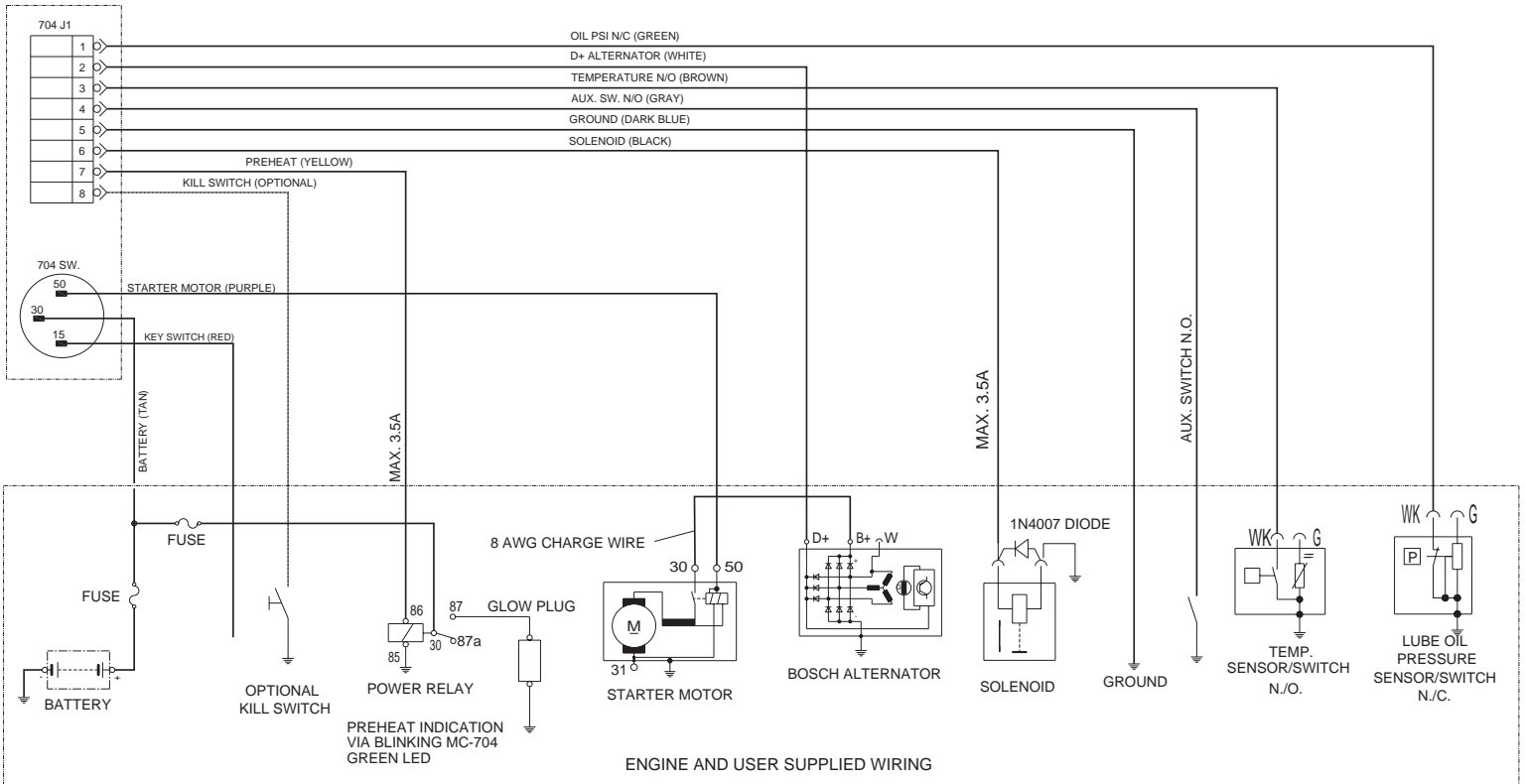

REDUCING VOLTAGE SPIKES

High Voltage spikes up to 1000V or more can occur momentarily when a relay or solenoid is switched off. Relay contacts, electronics, etc. can be damaged or malfunctions can occur if these spikes reach the electrical network without suppression. A **1N4007** diode should be used when using any of LOFA's products. Please install this diode as close as possible to the solenoid. Please note installing the diode incorrectly or reversing the polarity of the battery will damage the diode.

BLACK 16 AWG TO 704 #6

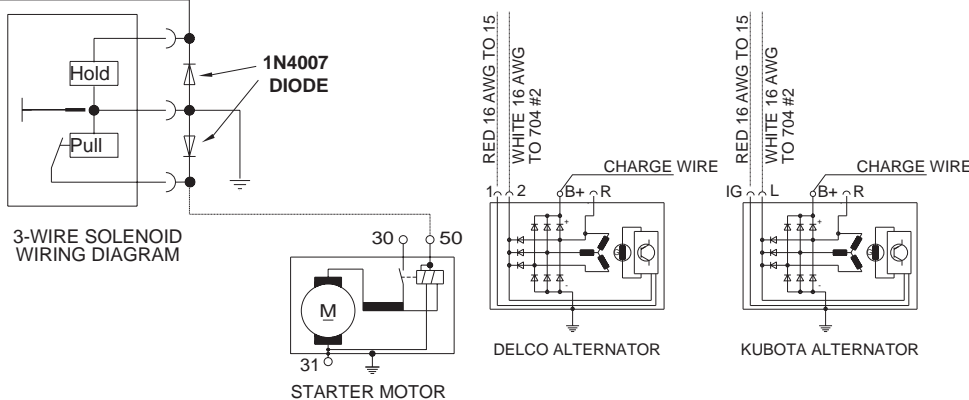

KEY SWITCH ELECTRICAL DIAGRAM				
POS.	0	I	II	CURRENT
30 - 83	█			2 A
30 - 75		█		20 A
30 - 15		←█		25 A
30 - 50		←█	█	50 A 12 A



PHONE 770 569 9828 FAX 770 569 9829 www.LOFA.net

©2002 LOFA Industries, Inc. LOFA Industries, Inc. is constantly striving to improve its products and must therefore reserve the right to change designs, materials, specifications and prices without notice. Printed in the USA. 9/03

250 Hembree Park Drive Suite 122 Roswell GA 30076

MC-704 SERIES SCHEMATIC WITH PREHEAT AND OVER-SPEED

MC 704 - LC / H

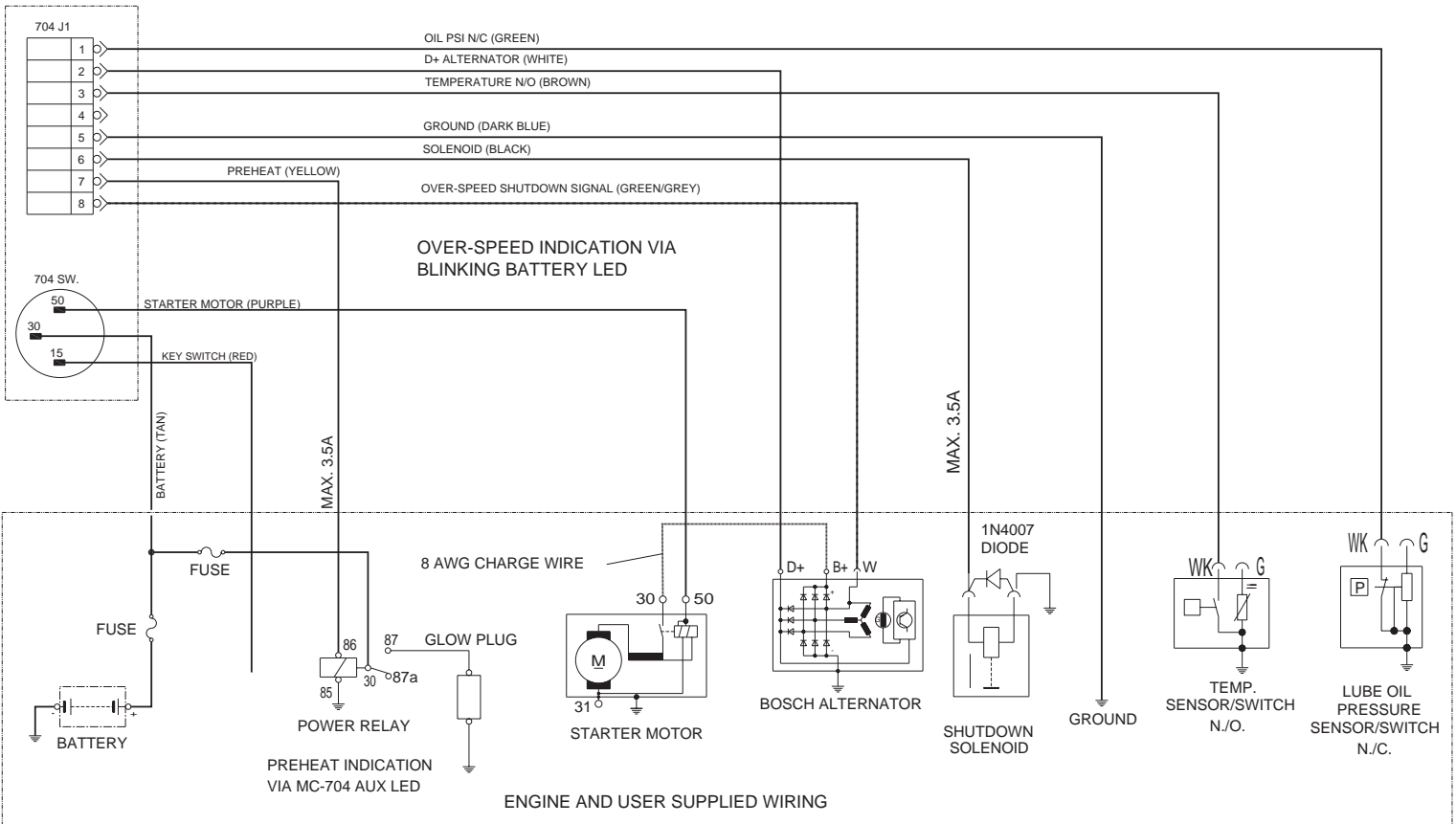

REDUCING VOLTAGE SPIKES

High Voltage spikes up to 1000V or more can occur momentarily when a relay or solenoid is switched off. Relay contacts, electronics, etc. can be damaged or malfunctions can occur if these spikes reach the electrical network without suppression. A **1N4007** diode should be used when using any of LOFA's products. Please install this diode as close as possible to the solenoid. Please note installing the diode incorrectly or reversing the polarity of the battery will damage the diode.

BLACK 16 AWG TO 704 #6

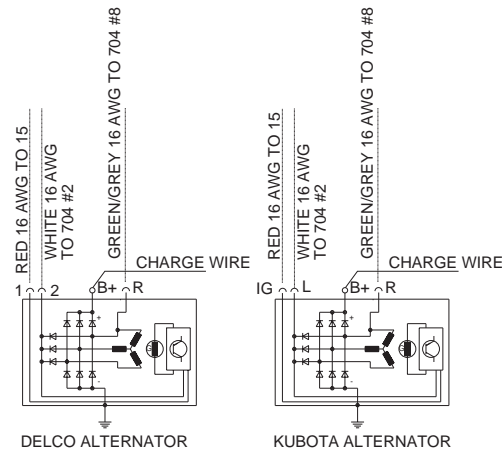
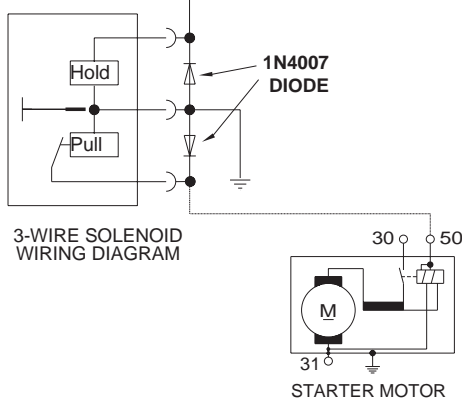

KEY SWITCH ELECTRICAL DIAGRAM

POS.	0	I	II	CURRENT
30 - 83	█			2 A
30 - 75		█		20 A
30 - 15		█	←	25 A
30 - 50			←	50 A 12 A



PHONE 770 569 9828 FAX 770 569 9829 www.LOFA.net

LOFA MC704 and MC704 G4 Operation and Troubleshooting

Introduction

This document provides general information on LOFA Industries MC704 control systems operation and troubleshooting. MC704 control systems are a very flexible platform for diesel engine control, monitoring, and protection, featuring LOFA's powerful First Fault Diagnostics (FFD). After pinpointing the initial failure, FFD stores it in memory and alerts the end user via a single bright LED. FFD monitors battery charge, low oil pressure, high temperature and one additional contact closure input. The microprocessor-based solid-state design uses high-power semiconductors instead of outdated electromechanical relays to ensure reliable high-current switching.

The MC704 panels are offered in two versions. The MC704HP has a built-in tamperproof LED hourmeter while the reduced cost MC704LCP eliminates the hourmeter. The G4 variant includes up to four 2 inch gauges. All panel versions can be factory configured with specific preheat & afterglow requirements. If preheat is not required, this output can function as an alarm.

All standard panels include feature a 12 inch wiring harness terminating into a sealed weather proof plug. This robust universal wiring connection performs well in harsh environments and allows interchanging a number of different panels and harnesses. This design allows for simplified installation as well as a flexible means to incorporate custom plug-and-play engine wiring harnesses and standard harness extension

Note

The engine harness is not included with the panel.

A number of standard engine harnesses are available or LOFA can develop a custom harness for you exact needs.

Generic harnesses in various lengths are available for field customization.

Warning

When replacement parts are required, LOFA Industries recommends using replacement parts supplied by LOFA or parts with equivalent specifications.

Failure to heed this warning can lead to premature failure, product damage, personal injury or death.

Important Safety Information

The warnings in this publication are not all inclusive.

LOFA Industries cannot anticipate every potential hazard.

Appropriate safety rules and precautions should be followed with any tool, work method or operating procedure.

Improper procedures, tools and materials may cause damage or make the equipment unsafe to operate.

Only persons with appropriate training, skills and tools should perform these functions.

Improper operation, maintenance or repair of this product can be dangerous and may result in injury or death.

Do not operate or perform any maintenance or repair on this product until all operation, maintenance and repair information is read and understood.

The information, specifications, and illustrations in this publication are based on information available at the time of publication.

All items are subject to change at any time without notice.

Operation

Turning the control system key to the run position starts a self-test which causes all LEDs to flash three times, activates the alarm output (if preheat is not used) for one second and enables the fuel run/stop solenoid output. After self-test, the LEDs indicate the state of the inputs they monitor. The normal indications are battery charge and oil pressure on most applications. If these LEDs are not illuminated at this time it may indicate the inputs are not properly connected.

The Preheat/OK LED begins to blink when the key switch is turned to the run position if automatic preheat is configured (See Preheat Options). Preheat time varies from application to application. After waiting for the Preheat/OK LED to become solid, the engine is cranked by turning and holding the key switch in the start position until the engine starts. The key switch is spring loaded to return automatically to the run position when released.

Note

The key switch is equipped with a mechanical start locking device. An attempt to re-crank the engine can only be made by turning the key switch to the off position to reset the start locking mechanism.

If the engine is not started within 30 seconds of turning on the system, the fuel run/stop solenoid output is turned off to prevent battery discharge when the key switch is left in the run position. The fuel run/stop solenoid output is turned off after 30 seconds even if preheating. As soon as the key switch is turned to the start position the solenoid output is enabled. The afterglow cycle begins when the key switch returns to the run position.

Note

If conditions do not warrant preheat, the engine may be started by turning the key to the start position without waiting for the preheat time to expire.

Control system instrument power, including the hourmeter and voltmeter, is provided by the fuel run/stop solenoid output. If the instruments do not power up when the key is turned to the run position, this indicates a problem with the solenoid circuit (see Troubleshooting).

After the engine starts, the control system electronics ignore all shutdown conditions for the first 10 seconds. This delay eliminates the requirement to hold a by-pass override button during starting and allows the system conditions such as oil pressure to normalize. The 10 second timer starts when the key switch returns to the run position.

Note

Starter input is required for correct system operation. If the starter motor input is not activated (connected to battery positive) and the engine is started through another means (i.e. air starter) the engine will shutdown 30 seconds after the key switch is turned to the run position.

To prevent unintentional engine shutdowns caused by intermittent conditions (i.e., pressure spikes, coolant movement) the control system requires a constant 1/3 second fault input to cause engine shutdown.

Warning

When used in combination with mechanical float type switches engine vibrations may prevent constant contact closure.

Preheat Options

Preheat Output

Preheat is a 3A positive output for control of an external power relay with predetermined preheat and afterglow times. A relay should be selected with appropriate amperage capacity for the installed cold starting aid (glowplug, intake air heater, etc.). Applications using multiple cold starting aids may require multiple relays.

Note

Consult engine documentation when selecting cold starting aid, power relay and heating specifications.

Indicators



Battery LED (Red)

A solidly illuminated Battery LED indicates a battery charge failure. A battery charge failure may be caused by a faulty alternator, broken drive belt or the alternator not excited. A battery voltage reading of approximately 14 volts on a 12 volt system (28 volts on a 24 volt system) while the engine is running indicates the battery is charging properly. Irregular blinking of the Battery LED may indicate a failing charge circuit. The system can be configured for battery charge failure to indicate only.



Oil Pressure LED (Red)

A solidly illuminated Oil Pressure LED indicates low oil pressure failure. The control system typically senses low oil pressure from a ground contact switch on the engine. When a sender/switch combination is used on the engine, the marking **WK** generally indicates the switch terminal. This input typically expects a normally closed switch (ground contact when oil pressure is low). A defective switch or shorting the shutdown input to ground can cause low pressure fault indication. Additionally, when using sender/switch combinations, swapping the **WK** and **G** terminal can cause unintended shutdowns. The system can be configured for oil pressure failure to indicate only.

Warning

Low oil pressure is not an indication of low oil level.

For best possible protection LOFA recommends using our solid-state oil level shutdown switch.

Note

Most shutdown switches are grounded through the switch body.
Do not use insulating sealant (i.e. Teflon tape) when installing switches.



Temperature LED (Red)

A solidly illuminated Temperature LED indicates high engine temperature failure. The control system typically senses high temperature from a ground contact switch on the engine. When a sender/switch combination is used on the engine, the marking **WK** or **W** generally indicates the switch terminal. This input typically expects a normally open switch (ground contact when engine temperature is too high). A defective switch or shorting the shutdown input to ground can cause over temperature fault indication. Additionally, when using

sender/switch combinations, swapping the **WK** or **W** and **G** terminal can cause unintended shutdowns. The system can be configured for temperature failure to indicate only.

Warning

If the temperature switch is not in contact with coolant due to coolant loss the engine is not protected from overheating.

For best possible protection, LOFA recommends using our solid-state coolant level shutdown switch.

Note

Most shutdown switches are grounded through the switch body. Do not use insulating sealant (i.e. Teflon tape) when installing switches.

Some thermostat housings are composites and do not provide ground for the switch.



AUX LED (Red)

A solidly illuminated AUX LED indicates an auxiliary failure (i.e., coolant level, oil level, belt breakage, hydraulic pressure, etc.). The control system typically senses failure using a ground contact switch. Auxiliary inputs are equipment specific and determined by the equipment manufacturer. A defective switch or shorting the shutdown input to ground can cause fault indications. The system can be configured for auxiliary failure to indicate only.

Preheat/OK LED (Green)

A blinking green Preheat/OK LED is the system preheat indication. When the LED changes to solid the preheat period is complete and the engine may be cranked. The LED changes to solid illumination when the engine starts. There is no indication of afterglow.

Harness

Sealed Connectors

The provided sealed weather proof plug includes a grey locking device which must be released to separate the connectors. Press the tab on the connector housing to release the connectors.

Warning

LOFA does not recommend using dielectric grease or sealant with sealed connectors.
These chemicals may cause seal damage and allow water entry.

Use LOFA provided cavity plugs to seal the connector if wires are removed.

Unsealed Connectors

For unsealed connectors exposed to the elements, LOFA recommends using dielectric grease to protect contacts.

Warning

LOFA does not recommend using sealant with unsealed connectors.
Sealant traps moisture in the connector and encourages corrosion.

Harness Routing

The minimum routing of radius of the wiring harnesses should be at least two times the diameter of the wiring harness. Bends should be avoided within 1 inch (25 mm) of any connector in order to avoid seal distortion allowing moisture to enter the connector.

Note

For harness length in excess of 10 ft a relay must be added to the start solenoid circuit.

LOFA offers starter relay kits for mounting near the engine.

Battery Circuit Requirements

Battery Positive Connection

The electronic control system operates on either a 12 VDC or 24 VDC electrical systems. The unswitched battery positive connection to the control system is made at the weather proof connector. The control system provides switched positive battery

Protection for the unswitched battery positive circuit is dependent on specific equipment configuration. The overload protection should not exceed 125% of the sum of all output currents plus 5 Amps for the control system. Powering the control system through dedicated circuits with appropriate overload protection reduces the possibility of system damage.

Circuit breakers are preferred over in-line fuses for circuit protection. Over current protection devices should ideally be located in a central location. If automatic reset circuit breakers are used, consideration of the environment of the breaker is critical and may affect the trip point. The trip point of some circuit breakers can be significantly reduced below the rated trip point if the circuit breaker is exposed to high temperatures.

Warning

Disconnecting the battery while the engine is running may damage electrical components.

When using a battery disconnect switch, LOFA recommends using a 2 pole switch to disconnect both the battery and alternator output.

Battery Negative Connection (Grounding)

Warning

Improper grounding can cause electrical noise, unreliable operation and may damage the control system or other components. All ground connections must be free from foreign materials, including paint, which may interfere with proper grounding.

A reliable ground must be provided for the control system.
LOFA recommends the ground connection be made directly to the battery negative.
Grounding through frame members is not recommended.

All ground paths must be capable of carrying any likely fault currents.

Do not reverse the battery polarity. Attempting to crank the engine when the polarity of the battery connections is reversed may damage the control system.

Note

A maximum of three ring terminals should be connected to a ground stud in order to ensure integrity of the ground connection. The use of more than three terminals can cause the connection to become loose.

Voltage Drop

If control system voltage drops below 6 volts for more than one tenth of a second, the control system may reset causing the self test to reactivate and the engine to shutdown after 30 seconds. Resetting the control

system is equivalent to quickly turning the key switch to off and back to run without starting the engine. Since the control system did not sense a start signal, the fuel run/stop solenoid deactivates after 30 seconds. Voltage drops can be caused by transients from external equipment, improper wire sizes, faulty wiring or nearby lightning strikes. In the absence of a *LOFA Power Box*, relays may be needed for long wire runs.

Suppression of Voltage Transients (Spikes)

Warning

The installation of voltage transient suppression at the transient source is required.

LOFA follows SAE recommended electrical environment practices.

Inductive devices such as relays, solenoids and motors generate voltage transients and noise in electrical circuits. Unsuppressed voltage transients can exceed SAE specifications and damage electronic controls.

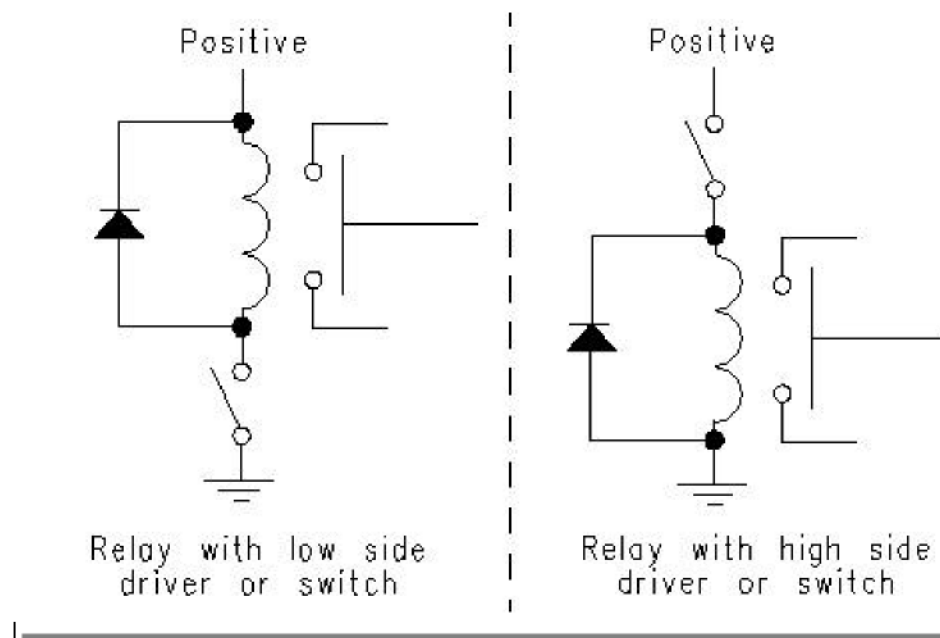

Relays and solenoids with built-in voltage transient suppression diodes are recommended whenever possible. Refer to the illustration for proper installation of diodes when built-in voltage transient suppression is not available.

Locate inductive devices as far as possible from the components of the electronic control system. When using electric motors it may also be necessary to add isolation relays to eliminate voltage transients, noise and prevent back feed.

Note

LOFA harness assemblies typically include all required engine control suppression devices. Added equipment will require additional protection.

Welding on Equipment with Electronic Controls

Proper welding procedures are required to avoid damage to electronic controls, sensors, and associated components. The component should be removed for welding if possible.

The following procedure must be followed if the component must be welded while installed on equipment with electronic controls. This procedure will minimize the risk of component damage.

Warning

Do not ground the welder to electrical components such as the control ground or sensors.
Improper grounding can cause damage to electrical components

Clamp the ground cable from the welder to the component being welded. Place the clamp
as close as possible to the weld to reduce the possibility of damage.

1. Stop the engine. Turn the key switch to the OFF position.
2. Disconnect the negative battery cable from the battery.
3. Open any installed battery disconnect switch.
4. Unplug the control system if possible.
5. Connect the welding ground cable as close as possible to the area to be welded.
6. Protect the wiring harness from welding debris and spatter.
7. Use standard welding methods to weld the materials.

General Troubleshooting

For additional information, refer to engine manufacturer troubleshooting guide.

No response from starter motor

Possible Cause	Possible Remedy
No battery voltage to starter	Verify wiring and battery connection (power and ground)
Battery discharged	Charge or replace battery, verify alternator charging
Tripped overcurrent protection	Correct fault, replace or reset overcurrent protection
No signal from control system	No power to control system (see Control System Troubleshooting below)
Defective starter solenoid	Replace starter solenoid
Defective starter motor	Replace starter motor

Engine will crank but not start

Possible Cause	Possible Remedy
Engine not getting fuel	Check fuel level, filter, fuel pump, verify no air in fuel lines
Fuel run/stop solenoid not engaged	See Fuel Solenoid Run/Stop Troubleshooting (below)
Tripped overcurrent protection	Correct fault, replace or reset overcurrent protection
No preheat (cold condition)	See Preheat Troubleshooting

Engine runs for 10 seconds and shuts down

Possible Cause	Possible Remedy
Shutdown switch input active	Verify shutdown source exists, correct condition or correct faulty circuit
Battery not charging	Verify alternator charging (see Alternator not charging battery below)
Control board did not sense start signal	Engine started through alternate method (i.e., manual air start, push start, etc.)
Defective control system	See Control Panel Troubleshooting (below)

Engine runs longer than 10 seconds and shuts down

Possible Cause	Possible Remedy
Shutdown switch input active	Correct engine fault, verify shutdown switch wiring
Circuit overload protection tripped	Correct overload, keep control system from overheating (over 185° F/85° C)
Voltage transients (spikes)	Add suppressor diodes, protect from nearby lightning strikes, shield induced spikes from other equipment, add electric motor control relay
Defective control system	See Control System Troubleshooting (below)

Alternator not charging battery

Possible Cause	Possible Remedy
Broken or slipping alternator drive belt	Adjust or replace alternator drive belt
Alternator not excited	Verify excitation circuit connected, replace faulty regulator, add additional excitation resistor
Alternator output not connected	Install charge wire
Alternator not grounded	Clean or add ground connection
Alternator faulty	Replace faulty alternator

Fuel Run/Stop Solenoid Troubleshooting**Engine does not stop immediately**

Possible Cause	Possible Remedy
Back feed from motor (i.e., cooling fan)	Add relay or blocking diode
Sticking solenoid linkage	Repair or replace solenoid linkage
Fuel valve without check valve	Install or repair check valve

Fuel run/stop solenoid does not engage

Possible Cause	Possible Remedy
No power to solenoid	Locate reason for lack of power and correct (Circuit overloaded? Failed suppressor diode? Faulty wiring?)
No power to solenoid pull coil	Correct faulty wiring, check pull control circuit (see Power Box Troubleshooting below)
Incorrect linkage adjustment	Adjust solenoid linkage
Faulty solenoid	Replace solenoid
Failed suppressor diode	Correct wiring (diode reversed?), replace suppressor diode
Optional e-stop engaged	Disengage e-stop

Engine not getting fuel

Possible Cause	Possible Remedy
Empty fuel tank	Fuel engine
Clogged filter	Replace filter
Air in fuel lines	Bleed fuel lines
Low fuel pressure	Replace faulty fuel pump and/or clogged filter
Faulty fuel pump	Replace fuel pump, correct wiring fault (electric fuel pump)

Preheat Troubleshooting**Engine is hard to start in cold conditions**

Possible Cause	Possible Remedy
Start attempt before preheat complete	Wait for preheat time to elapse, crank as soon as time elapses
Incorrect preheat specification	Correct control system configuration, install correct control system
Heater faulty	Replace heater
Heater relay faulty	Replace relay
Preheat control not functioning	Correct wiring, correct control system configuration
Faulty control system	See Control System Troubleshooting (below)

Engine produces excessive white smoke after starting

Possible Cause	Possible Remedy
Afterglow not enabled	Reconfigure control system
Heater faulty	Replace heater
Heater relay faulty	Replace relay
Preheat control not functioning	Correct wiring, correct control system configuration
Faulty control system	See Control System Troubleshooting (below)

Control System Troubleshooting

Control system does not perform self test

Possible Cause	Possible Remedy
Tripped overcurrent protection	Correct fault, replace or reset overcurrent protection
Faulty connection to battery	Correct battery connections (see Battery Circuit Requirements above)

Control system performs normal self test, engine cranks, runs and shuts down

Possible Cause	Possible Remedy
Only Battery LED illuminated	Correct battery charge failure (see Battery not charging above)
Only Oil Pressure LED Illuminated	Correct low oil pressure condition or faulty switch, correct wiring fault
Only Temperature LED Illuminated	Correct overheating condition or faulty switch, correct wiring fault
Only Aux LED Illuminated	Correct fault condition (i.e. v-belt, coolant level) or faulty switch, correct wiring fault
All normally closed shutdowns illuminate for one second (control system reset)	Add suppressor diodes, protect from nearby lightening strikes, shield induced spikes from other equipment, add electric motor control relay

Testing Shutdown Inputs

Shutdown switches signal a fault by ground contact in most systems. Shutdown operation can be verified by grounding the shutdown inputs individually. It may be necessary to remove the wire from the shutdown switch to perform this test.

Note

Most shutdown switches are grounded through the switch body.
Do not use insulating sealant (i.e. Teflon tape) when installing switches.

Some thermostat housings are composites and do not provide ground for the switch.

" Power Box Option

The Power Box is a solid state, high current control system for mechanically governed, industrial diesel engines. In addition to allowing extended harnesses, the Power Box provides 3-wire fuel run/stop solenoid control to protect the pull coil from overheating. Power Box technology typically controls the starter solenoid, fuel run/stop solenoid and cold starting aid. All outputs are overload protected and the system is fused to avoid damage in the event of excess current demand. An additional fuse protects the control circuitry.

Warning

The Power Box is reverse polarity protected but may be damaged by attempting to start the engine with battery polarity reversed.

When the fuel solenoid input is enabled, the fuel run/stop solenoid pull coil is enabled for the first second. In normal operation, all other Power Box outputs are active as long as their corresponding inputs are active.

Power Box Troubleshooting

One output never activates

Possible Cause	Possible Remedy
Input not active	See Control System Troubleshooting (above)
Output shorted	Correct fault
Failed Power Box	Replace Power Box/harness assembly

All outputs never activate

Possible Cause	Possible Remedy
Blown fuse(s)	Correct fault, replace fuse(s)
Faulty connection to battery	Correct battery connections (see Battery Circuit Requirements above)
Failed Power Box	Replace Power Box/harness assembly

Fuel run/stop solenoid pull output remains active

Possible Cause	Possible Remedy
Faulty wiring	Correct wiring
Faulty connection to battery	Correct battery connections (see Battery Circuit Requirements above)
Failed Power Box	Replace Power Box/harness assembly

Revision History

Initial Release.

Rev A – 22-May-2006. Corrected typographical errors.

Rev B – 26-Oct-2006. Add symbols to *Indicators*, corrected typographical errors.

Rev C – 8-Jan-2007. Updated schematics

Rev C.1 – 28-Feb-2007. Added part numbers.

Typical Schematics

The following pages show typical schematics.

Details vary from installation to installation.

See the specific schematics for installation for details.

Need MC704 GT Panel Drawing

LOFA MC704 and MC704 G4 Operation and Troubleshooting

THE INFORMATION CONTAINED IN THIS DRAWING IS CONFIDENTIAL AND THE SOLE PROPERTY OF LOFA INDUSTRIES INC. Reproduction or dissemination in whole or in part in any form or medium without express prior/written permission of LOFA INDUSTRIES INC is prohibited.

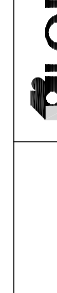
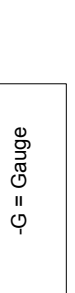
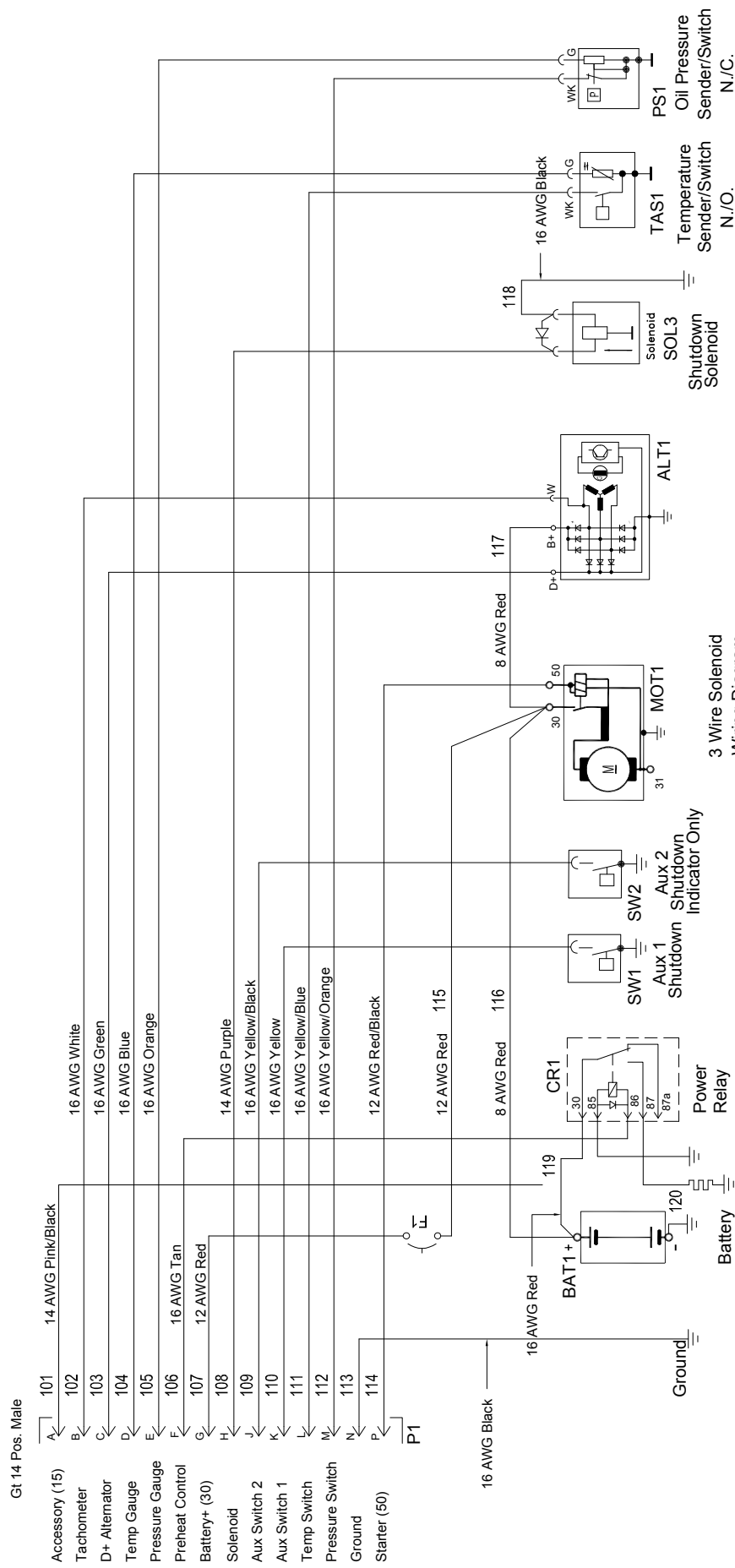

Note: -WK = Switch
-G = Gauge



Description: MC-538 Engine Generac Diagram With GT Male		Tolerances: X .XX .XXX ANG ^o	
Part Number:		+/- .1 .02 .005 2 ^o	
Rev	Drawn By: MThiam	Date:	Sheet 1 of 1
250 Hembree Park Dr, Ste 122 Roswell, GA 30076		phone: 770-569-9828	www.LOFA.net
Fax: 770-569-9829			

Leece-Neville Alternator

12 Volt, 185 Amps

24 Volt, 100, 150 & 175 Amps

The 8SC series is ideally suited for applications with extra heavy electrical loads and high charge at idle. These alternators have integral charging systems for heavy belt loads and extremely high electrical loads on large diesel or gasoline engines.

Features & Benefits

- Simplified wiring - insulated three wire system
- Built-in "Load Dump" protected regulator with solid state circuitry and external adjustment
- Varnished stator
- 7/8" heavy-duty shaft
- SAE double lug mount with adjustable steel bushing and steel insert
- Heavy-duty 5/16" output stud for superior electrical connections
- Special AC terminal for connection of tachometers and other instruments. Also "R" terminal for indicator lamp hook-up
- Long life copper graphite brushes enclosed in a dirt resistant chamber to extend brush life.
- The dynamically balanced rotor and shaft assembly utilizes a 25 mm ball bearing at the drive end and a 20 mm roller bearing. Both have grease reservoirs and protective seals to provide long life and smooth operations.
- Internal and external capacitors to suppress radio frequency interference
- 12 volt units have a trash screen for protection against foreign particles

8SC Series

24 Volt, 100, 150 & 175 Amps



8SC Series

12 Volt, 185 Amps with trash screen



Applications

- Off-Highway
- Agriculture
- Emergency Vehicles
- Heavy Duty Trucks
- Transit Buses

Dimensions

(dimensions in inches)

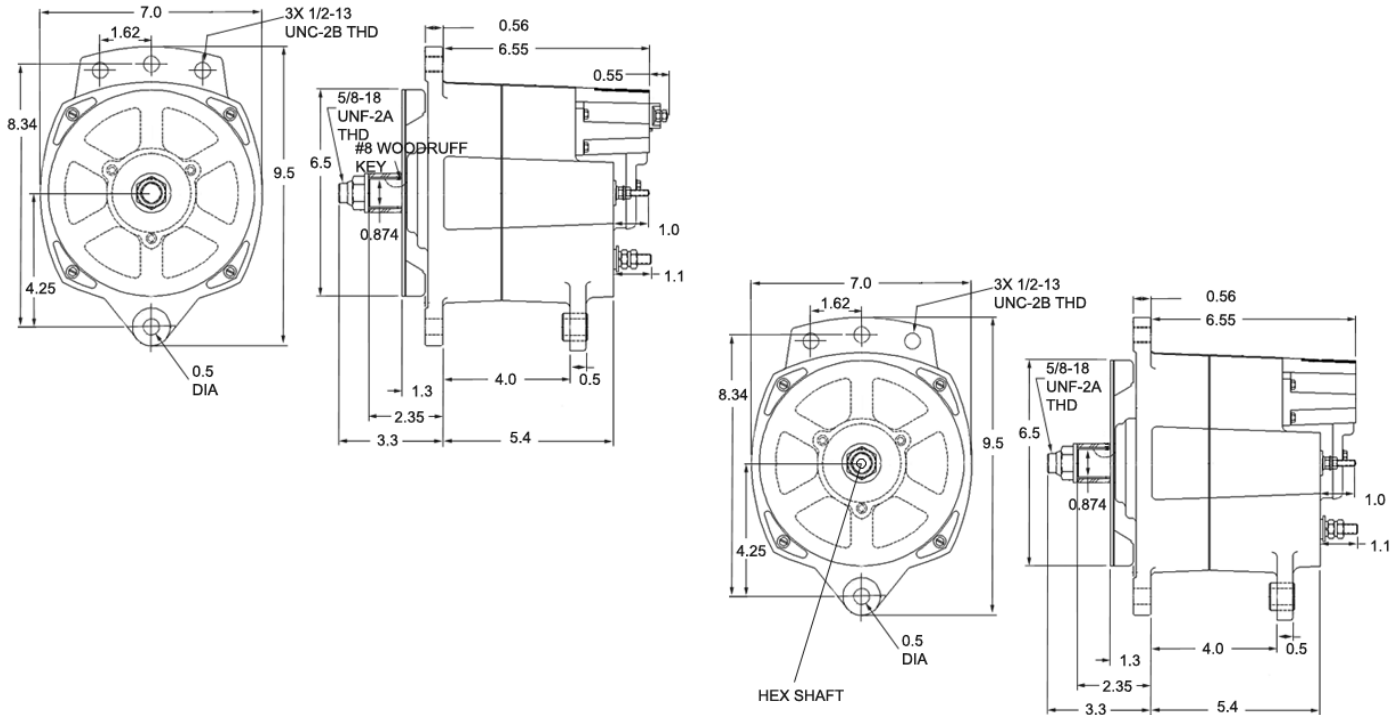

Specifications

		12 VOLT		24 VOLT		
Dual Foot	Model No.	8SC2020Z	8SC2023Z	8SC3014U	8SC3015U	8SC3019U
J-180 Mount	Sales No.	110-563	110-565	110-298	110-302	110-316
Output, Stabilized:						
5000 RPM		185	185	100	100	100
2500 RPM		153	153	78	84	84
Temperature Range		-40 C to 93 C	-40 C to 93 C	-40 C to 93 C	-40 C to 93 C	-40 C to 93 C
Rotation Direction		Bi- Directional	Bi- Directional	Bi- Directional	Bi- Directional	Bi- Directional
Max. Speed RPM		8000	8000	8000	8000	8000
Excitation Type		Self	Self	Ignition	Ignition	Ignition
Lamp Circuit		-	.25 Amps	-	-	-
Ground		Isolated	Isolated	Isolated	Isolated	Isolated
Regulator Set Point Voltage		14.2	14.0	28.0	28.0	28.0
Voltage Adjustment		-	-	+/-1.0v	+/-1.0v	+/-1.0v
Regulator Part #		8RL2104	8RL2105	8RL3022	8RL3021	8RL3021
Weight (lbs/Kg)		27.75/12.6	27.75/12.6	27.75/12.6	27.75/12.6	27.75/12.6
Terminal Size: B+		5/16"-24	5/16"-24	M8-1.25	5/16"-24	5/16"-24
B-		1/4"-28	1/4"-28	M6-1.25	1/4"-28	1/4"-28
AC		10-24	10-24	10-24	10-24	10-24
"l" Lamp		-	10-24	-	-	-
Ignition		-	-	M5-.8	10-24	10-24
Notes:			Lamp Driver			

Wire Diagrams

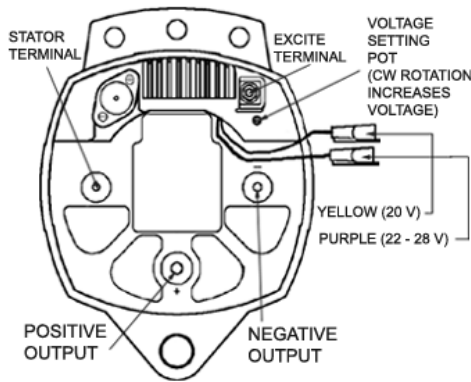

8SC3017VA,
8SC3018VA &
8SC3110V

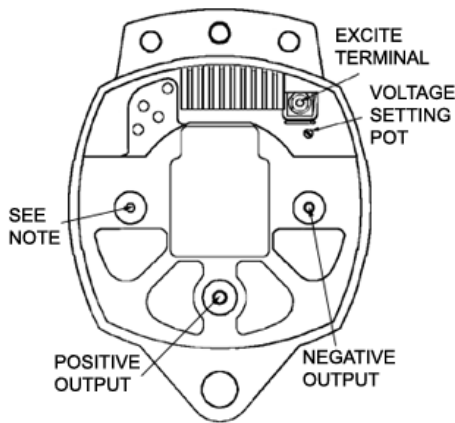

8SC2020Z, 8SC2023Z,
8SC3014U, 8SC3009ZA,
8SC3068V & 8SC3029Z

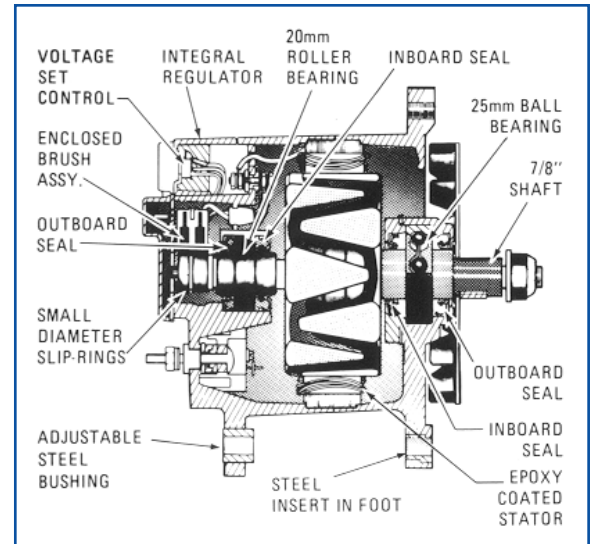

Note:

8SC2020Z & 8SC2023Z = Stator Terminal

8SC3029Z, 8SC3068V &
8SC3009ZA = Indicator Light Terminal

8SC3014U = D+ Terminal

8SC3029ZA = Has Stator Lead

Specifications

		24 VOLT					
Dual Foot	Model No.	8SC3017VA	8SC3018VA	8SC3068V	8SC3110V	8SC3009ZA	8SC3029Z
J-180 Mount	Sales No.	110-575	110-579	110-431	110-568	110-258	110-569
Output, Stabilized:							
5000 RPM		150	150	150	150	175	175
2500 RPM		98	98	97	120	54	80
Temperature Range		-40 C to 93 C	-40 C to 93 C	-40 C to 93 C	-40 C to 93 C	-40 C to 93 C	-40 C to 93 C
Rotation Direction		Bi- Directional	Bi- Directional	Bi- Directional	Bi- Directional	Bi- Directional	Bi- Directional
Max. Speed RPM		8000	8000	8000	8000	8000	8000
Excitation Type		Ignition	Ignition	Ignition	Ignition	Ignition	Ignition
Lamp Circuit		-	-	-	-	-	-
Ground		Isolated	Isolated	Isolated	Isolated	Isolated	Isolated
Regulator Set Point Voltage		28.0	28.0	28.0	28.0	28.0	28.0
Voltage Adjustment		+1.0v	+1.0v	+1.0v	+1.0v	+1.0v	+1.0v
Regulator Part #		8RL3013	8RL3013	8RL3021	8RL3013	8RL3021	8RL3021
Weight (lbs/Kg)		27.75/12.6	27.75/12.6	27.75/12.6	27.75/12.6	27.75/12.6	27.75/12.6
Terminal Size:	B+	5/16"-24	5/16"-24	5/16"-24	5/16"-24	5/16"-24	5/16"-24
	B-	1/4"-28	1/4"-28	1/4"-28	1/4"-28	1/4"-28	1/4"-28
	AC	10-24	10-24	10-24	10-24	10-24	10-24
	"I" Lamp	-	-	-	-	-	-
	Ignition	10-24	10-24	10-24	10-24	10-24	10-24
Notes:		Remote Sense Batteryless	Remote Sense Batteryless		Remote Sense Batteryless		

Product Performance Stabilized Performance @ 25°

24 Volt, 150 Amps 8SC3017VA & 8SC3018VA

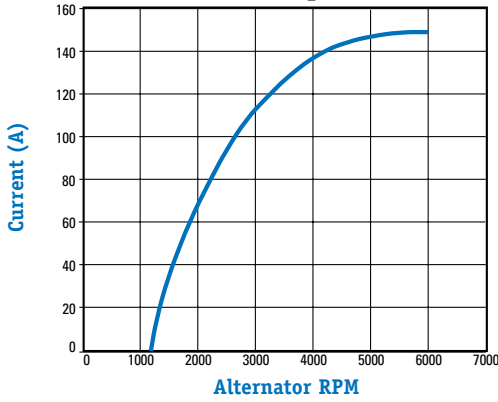

12 Volt, 185 Amps 8SC2020Z & 8SC2023Z

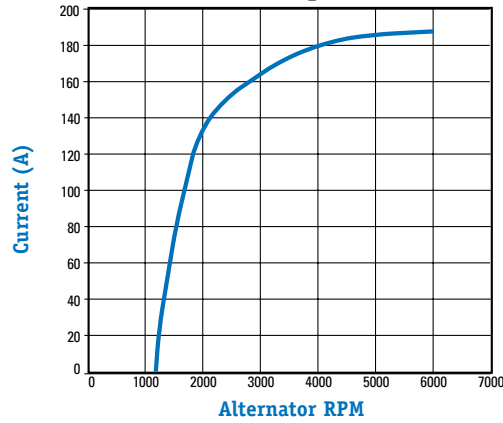

24 Volt, 150 Amps 8SC3068V

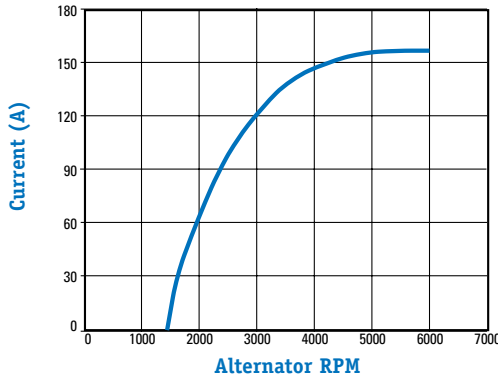

24 Volt, 100 Amps 8SC3014U

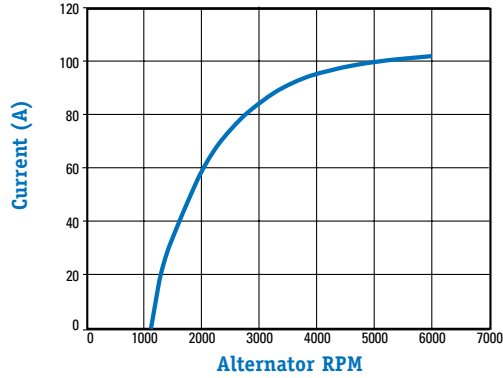

24 Volt, 150 Amps 8SC3110V

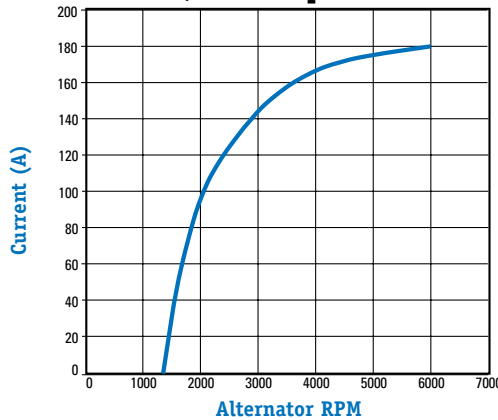

24 Volt, 175 Amps 8SC3009Z

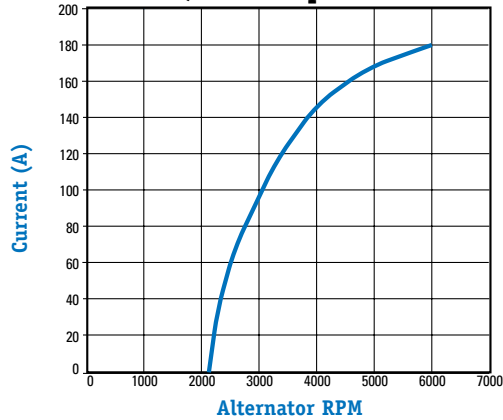

Source: Leece-Neville Heavy Duty Systems Division - Arcade, NY USA
 Date: March 25, 2008
 Bulletin No: TSB-1031
 Models: 8SC Series Batteryless Alternators
 Subject: Batteryless Alternator System

One of the Batteryless alternator's uses is to power a bus air conditioning system. The alternator gets its field current from the vehicle primary electrical system. No batteries are needed in this circuit. It is recommended to operate it at 3500 RPM minimum.

Because this alternator was designed for the batteryless system, Leece-Neville technical services recommends **NOT** connecting it to a battery. Connecting two alternators together is **NOT** recommended, due to the difficulty of the two alternators to share the load.

For further information regarding this system, or for information on other recommendations, please contact the technical service representative in your area or call our technical service call center at the number listed below. Other technical bulletins, as well as a technical region map, are available on our website at www.prestolite.com.

GENERIC WIRING DIAGRAM FOR BATTERYLESS SYSTEMS

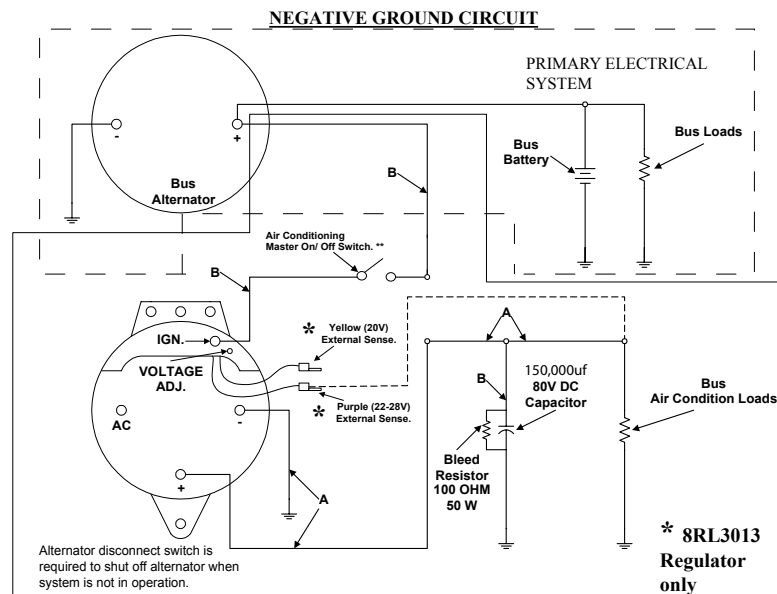

** Switch must be open when AC unit is turned off and closed when AC unit is turned on.

RECOMMENDED MIN. WIRE SIZES

SYSTEM RATING	TOTAL LENGTH OF CHARGING CIRCUIT	A	B
65 A	12 FEET OR LESS	#8	#16
	12-20 FEET	#6	#14
85A	15 FEET OR LESS	#6	#16
	15-20 FEET	#4	#14
105A	12 FEET OR LESS	#6	#16
	12-20 FEET	#4	#14
130A	15 FEET OR LESS	#4	#16
	15-25 FEET	#2	#14

Important: The information contained in this bulletin is intended for use by trained, professional technicians who have the proper tools, equipment, and training to perform the required maintenance described above. This information is NOT intended for 'do-it-yourselfers', and you should not assume that this information applies to your equipment. If you have any questions regarding this information please visit our website at www.prestolite.com, or contact our technical service department at:

Source: Leece-Neville Heavy Duty Systems Division - Arcade, NY USA
Date: July 18, 2008
Bulletin No: TSB-1105
Models: All 8SC/ SCJ
Subject: K183103997S Overhaul Kit Procedure.

This procedure will show you how to install items supplied with K183103997S overhaul kit. Use procedure TSB-1068 to properly disassemble and assemble the alternator.

Front bearing change:

Step 1: Remove steel washer and felt seal from shaft. (Fig 1)

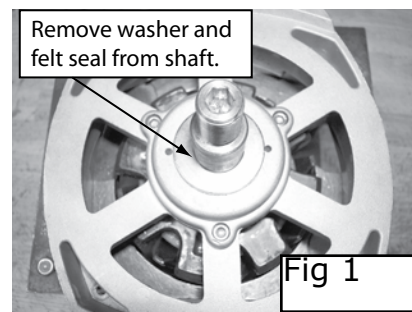

Step 2: Press rotor from front housing. (Fig 2)

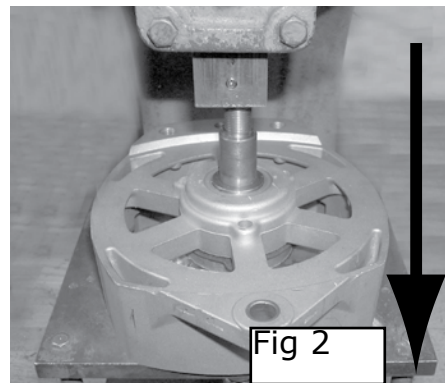

Step 3: Remove spacer and three front bearing retaining screws. (Fig 3)

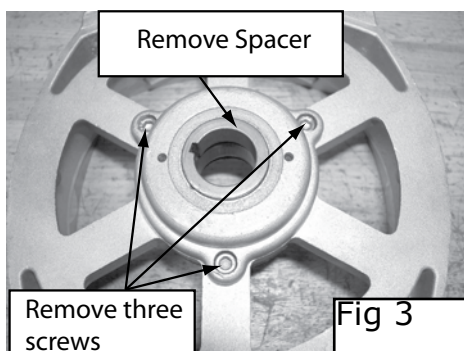

Step 4: Press front bearing and seals from front housing. (Fig 4)

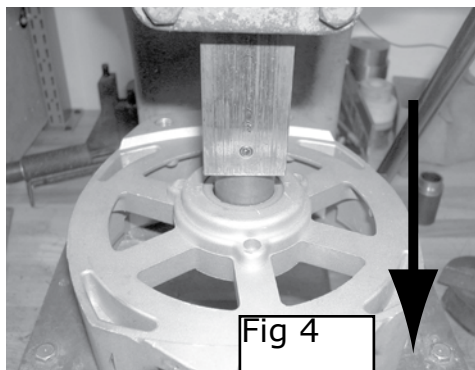

Important: The information contained in this bulletin is intended for use by trained, professional technicians who have the proper tools, equipment, and training to perform the required maintenance described above. This information is NOT intended for 'do-it-yourselfers', and you should not assume that this information applies to your equipment. If you have any questions regarding this information please visit our website at www.prestolite.com, or contact our technical service department at:

Date: July 18, 2008

Bulletin No: TSB-1105

Step 5: Remove seal from front housing.
(Fig 5)

Step 6: Remove seal from front bearing
retainer. (Fig 6)

Note: On opposite sides of the front housing
and bearing retainer are two holes. Insert a
punch into these holes and tap with a ham-
mer to remove the seals.

Step 7: Insert front housing seal. (Fig 7)

Step 8: Insert front bearing retainer seal.
(Fig 8)

Note: When installing seals, press on the
outer diameter. Failure to do this can cause
damage to the seals.

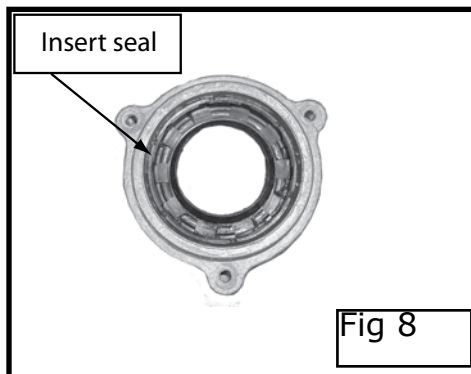
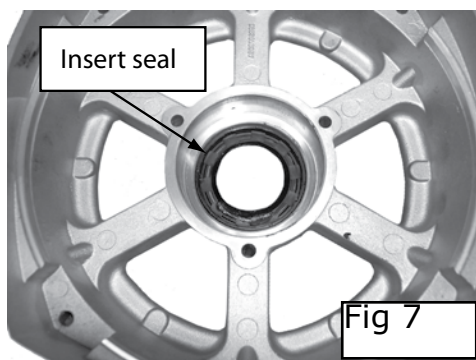
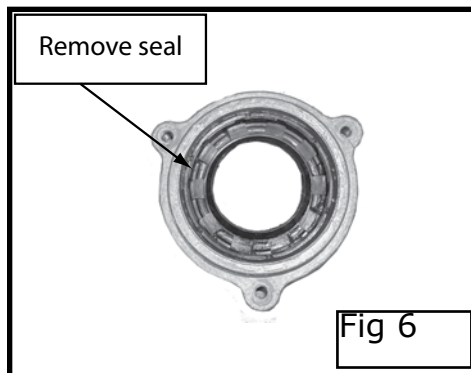
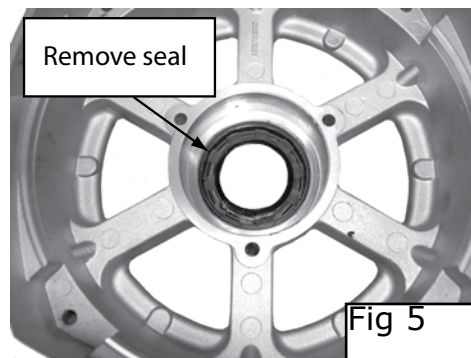

Important: The information contained in this bulletin is intended for use by trained, professional technicians who have the proper tools, equipment, and training to perform the required maintenance described above. This information is NOT intended for 'do-it-yourselfers', and you should not assume that this information applies to your equipment. If you have any questions regarding this information please visit our website at www.prestolite.com, or contact our technical service department at:

Date: July 18, 2008
Bulletin No: TSB-1105

Step 9: Press bearing into front housing. (Fig 9)

Note: When installing bearings, press on the outer diameter. Failure to do this can cause damage to the bearing.

Step 10: Install front bearing retainer. (Fig 10)

Step 11: While holding front bearing retainer in place, turn over housing. Apply blue locktite to three mounting screws and install into front housing. (Fig 11)

Step 12: With a grease needle, inject grease between the seal and the bearing.

Note: Grease needle can be purchased at any auto parts store.

Recommended grease:

High temperature synthetic bearing grease.

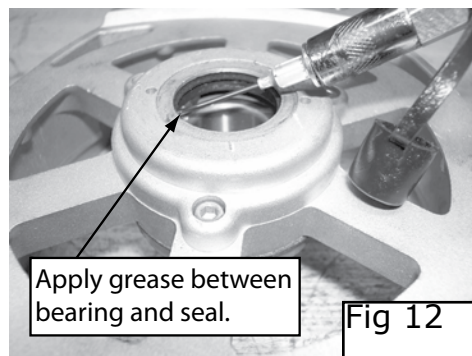
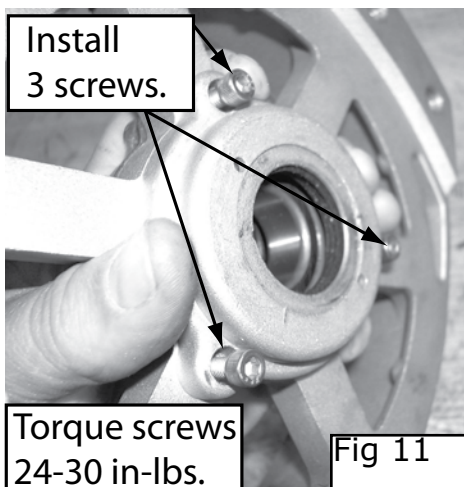
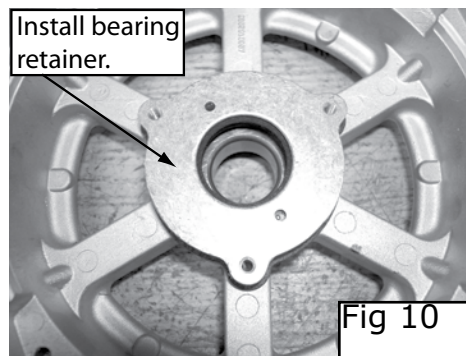
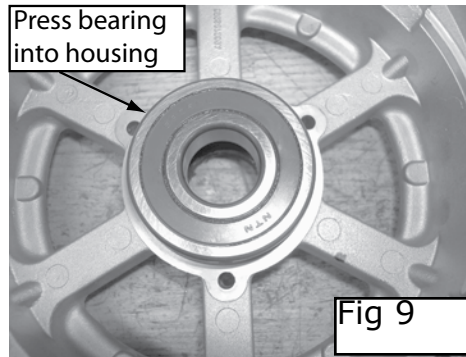

Important: The information contained in this bulletin is intended for use by trained, professional technicians who have the proper tools, equipment, and training to perform the required maintenance described above. This information is NOT intended for 'do-it-yourselfers', and you should not assume that this information applies to your equipment. If you have any questions regarding this information please visit our website at www.prestolite.com, or contact our technical service department at:

Date: July 18, 2008
Bulletin No: TSB-1105

Step 13: Turn housing over and with the grease needle inject grease between the seal and the bearing. (Fig 13)

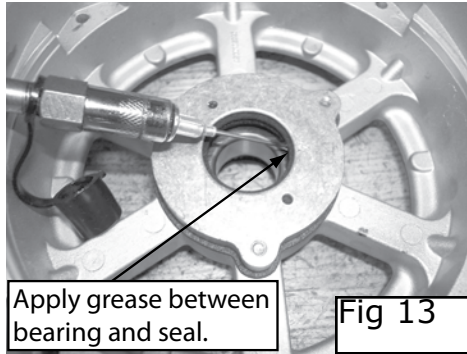

Step 14: Figure 14 and 15 shows the proper amount of grease that needs to be applied.

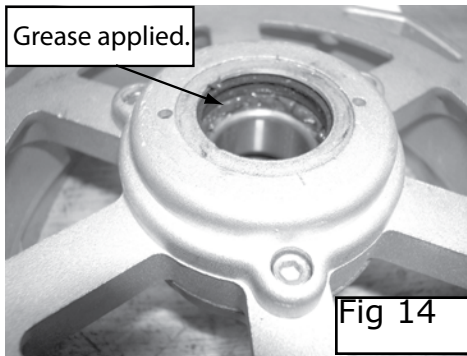

Note: The grease added between the bearing and the seals adds an additional protective measure in preventing dust from penetrating the bearing. This grease provides no lubricating properties to the front bearing.

Figure 16 shows you the proper arrangements of components in the front housing.

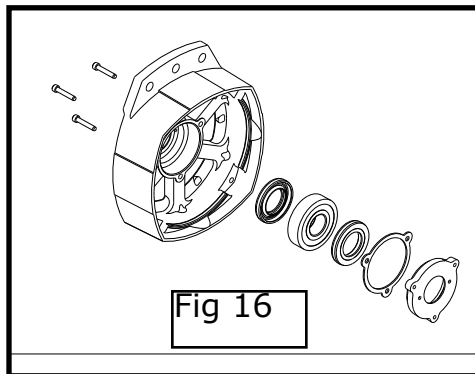
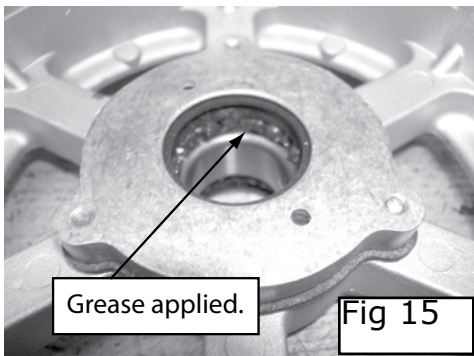

Important: The information contained in this bulletin is intended for use by trained, professional technicians who have the proper tools, equipment, and training to perform the required maintenance described above. This information is NOT intended for 'do-it-yourselfers', and you should not assume that this information applies to your equipment. If you have any questions regarding this information please visit our website at www.prestolite.com, or contact our technical service department at:

Date: July 18, 2008

Bulletin No: TSB-1105

Slip ring/ rear bearing inner race change:

Inspect rotor and measure key items in Fig 17.

If Dim A or B is out of tolerance a new rotor will need to be purchased. Refer to SP-1017 to determine correct replacement part number.

If Dim C or D is out of tolerance or excessive wear is present then proceed with this procedure.

Note: Use caution not to damage field wires during the following procedures.

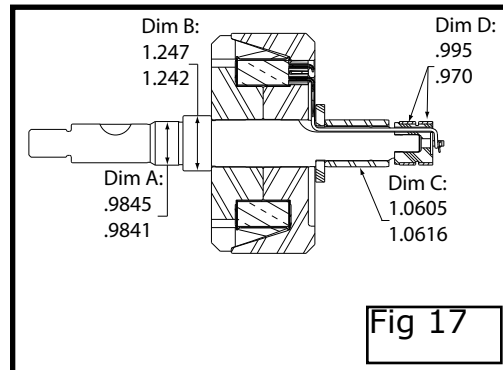

Step 15: Unsolder field wires from slip ring.
(Fig 18)

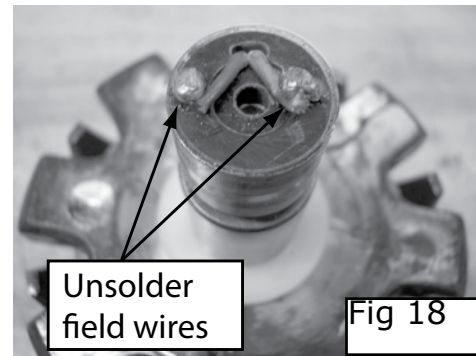

Step 16: Remove slip ring from shaft. (Fig 19)
Note: Use caution not to damage end of shaft during slip ring removal.

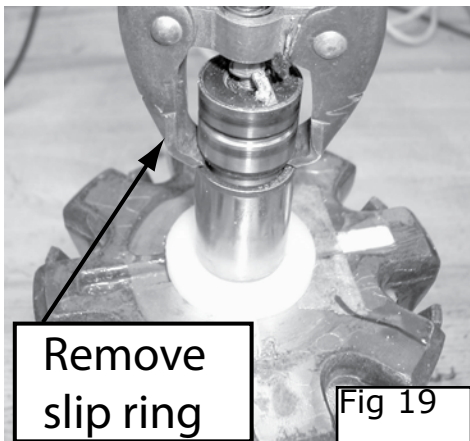

Step 17: Cut nylon spacer off shaft and discard.
(Fig 20)

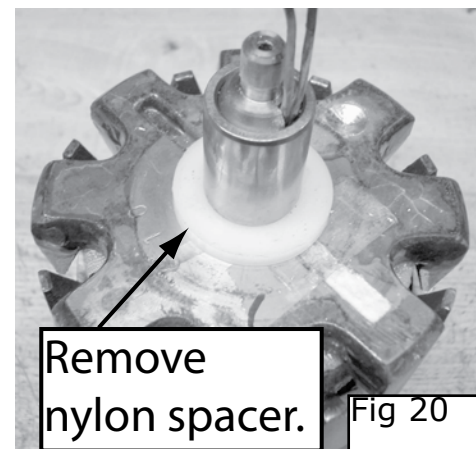

Important: The information contained in this bulletin is intended for use by trained, professional technicians who have the proper tools, equipment, and training to perform the required maintenance described above. This information is NOT intended for 'do-it-yourselfers', and you should not assume that this information applies to your equipment. If you have any questions regarding this information please visit our website at www.prestolite.com, or contact our technical service department at:

Date: July 18, 2008

Bulletin No: TSB-1105

Step 18: Clamp on bearing separator and press bearing inner race off shaft. (Fig 21)

Note: Use caution not to damage shaft or field wires.

Step 19: Apply high temperature silicone sealant on rotor. (Fig 22)

Step 20: Place new nylon spacer on shaft. (Fig 23)

Step 21: Press bearing inner race onto shaft. (Fig 24)

Note: Use caution not to damage field wires during installation.

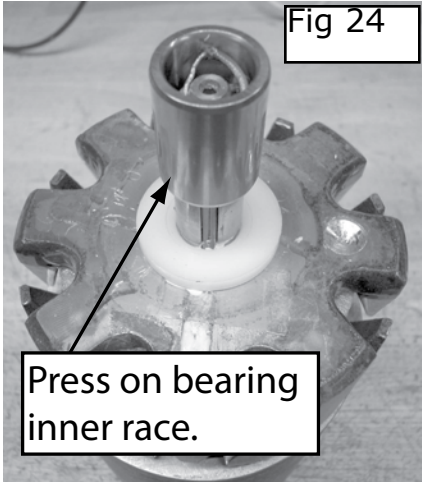
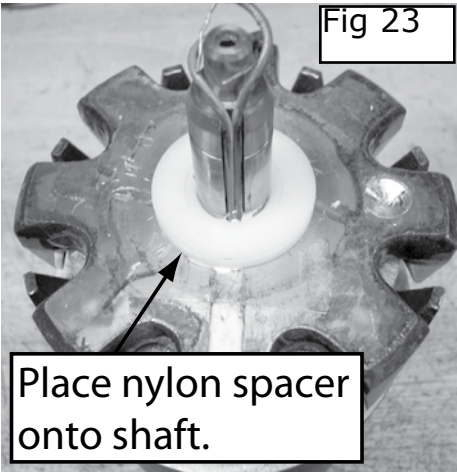
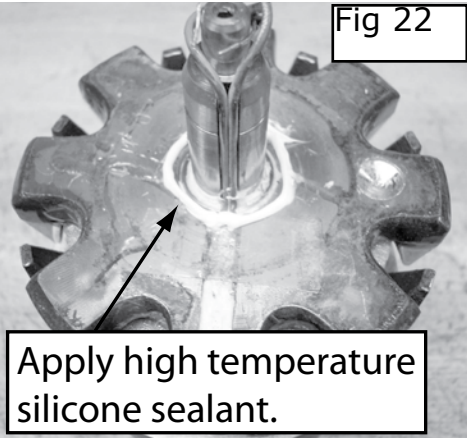
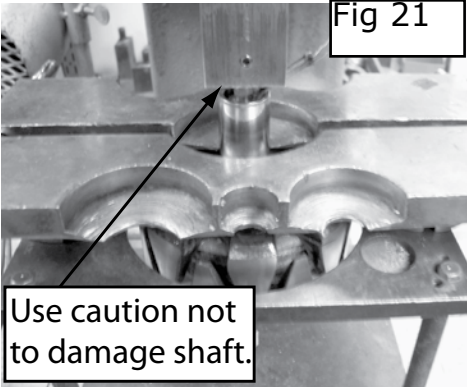

Important: The information contained in this bulletin is intended for use by trained, professional technicians who have the proper tools, equipment, and training to perform the required maintenance described above. This information is NOT intended for 'do-it-yourselfers', and you should not assume that this information applies to your equipment. If you have any questions regarding this information please visit our website at www.prestolite.com, or contact our technical service department at:

Date: July 18, 2008

Bulletin No: TSB-1105

Step 22: Insert field wires through slip ring.
(Fig 25)

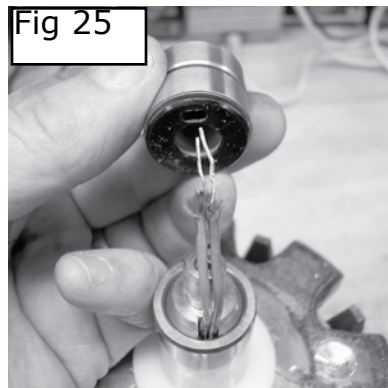

Step 23: Press slip ring onto shaft. (Fig 26)

Note: Use caution not to damage field wires while performing Step 23 and press on slip ring outer diameter to prevent damage.

Step 24: Wrap field wires around slip ring posts and solder.

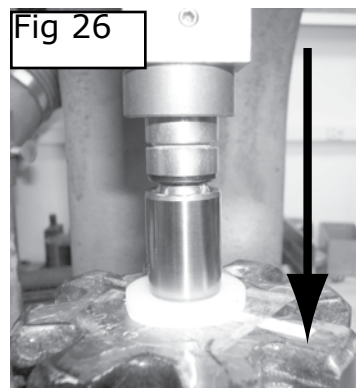

Recommended solder: SN15PB85

Figure 28 shows you the proper arrangements of components in the rotor.

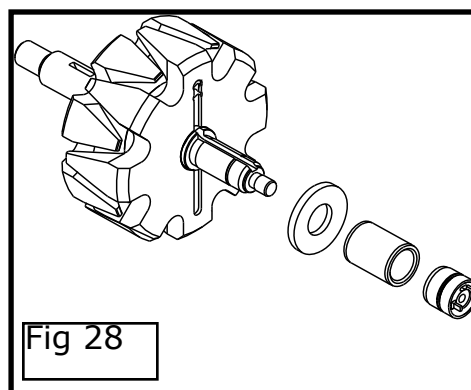
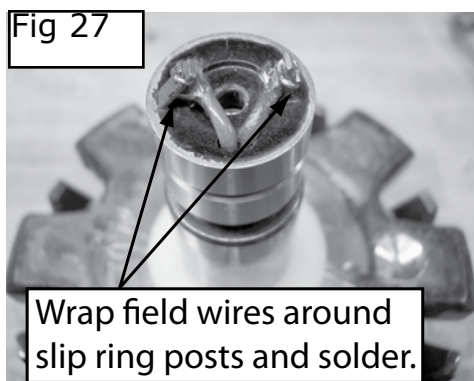

Important: The information contained in this bulletin is intended for use by trained, professional technicians who have the proper tools, equipment, and training to perform the required maintenance described above. This information is NOT intended for 'do-it-yourselfers', and you should not assume that this information applies to your equipment. If you have any questions regarding this information please visit our website at www.prestolite.com, or contact our technical service department at:

Date: July 18, 2008
Bulletin No: TSB-1105

Rear bearing change:

Step 25: Remove snap ring from rear housing.
(Fig 29)

Step 26: Press old seals and bearing from rear housing. (Fig 30)

Step 27: Pack new bearing and seal cavities with grease. (Fig 31)

Recommended grease:

High temperature synthetic bearing grease.

Step 28: Press seal into rear housing. (Fig 32)

Note: When installing seals, press on the outer diameter. Failure to do this can cause damage to the seals.

Use caution not to contaminate grease.

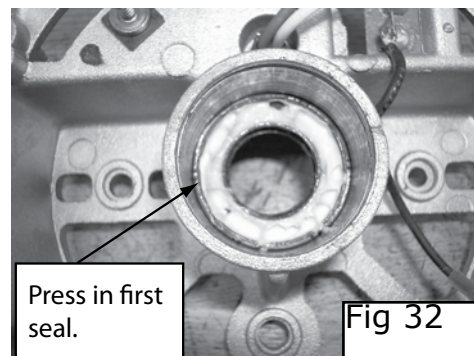
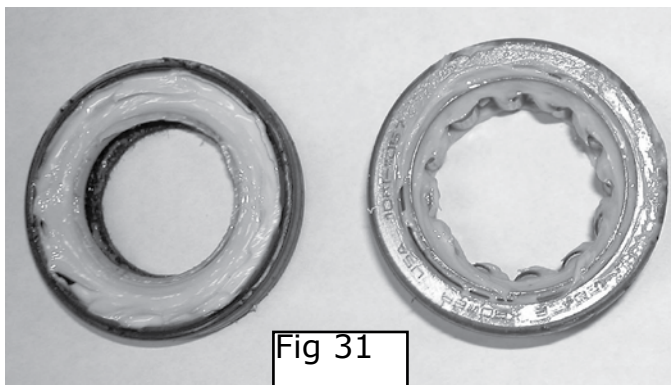
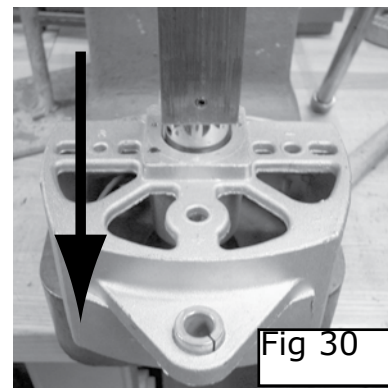
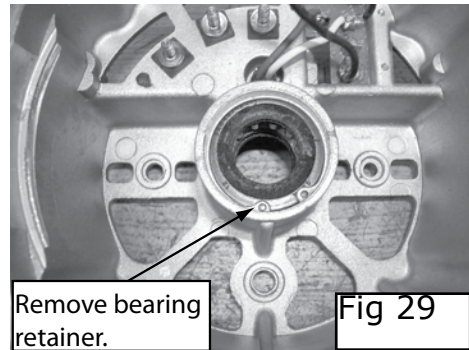

Important: The information contained in this bulletin is intended for use by trained, professional technicians who have the proper tools, equipment, and training to perform the required maintenance described above. This information is NOT intended for 'do-it-yourselfers', and you should not assume that this information applies to your equipment. If you have any questions regarding this information please visit our website at www.prestolite.com, or contact our technical service department at:

Date: July 18, 2008

Bulletin No: TSB-1105

Step 29: Press bearing into rear housing.
(Fig 33)

Note: When installing bearings, press on the outer diameter. Failure to do this can cause damage to the bearing.

Step 30: Press seal into rear housing. (Fig 34)

Step 31: Install snap ring into rear housing.
(Fig 35)

Figure 36 shows you the proper arrangements of components in the rear housing.

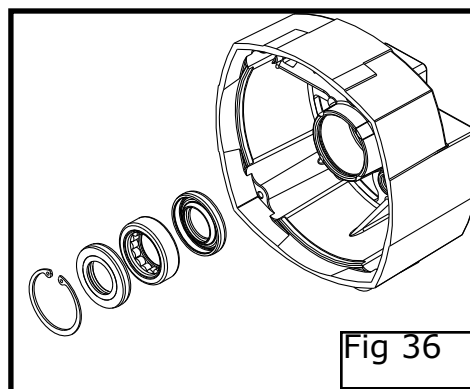
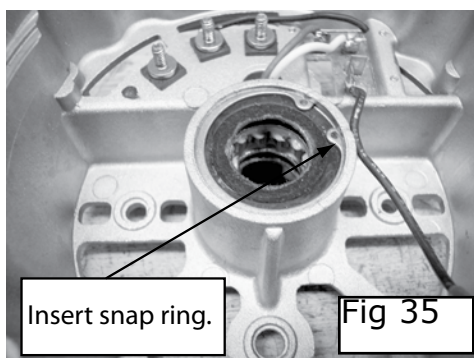
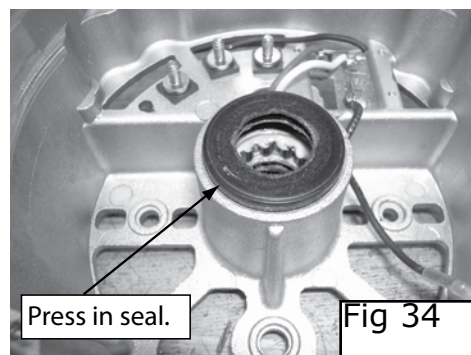
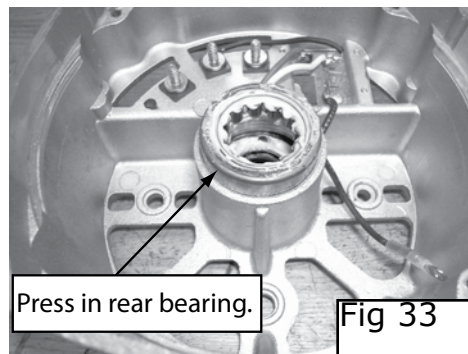

Important: The information contained in this bulletin is intended for use by trained, professional technicians who have the proper tools, equipment, and training to perform the required maintenance described above. This information is NOT intended for 'do-it-yourselfers', and you should not assume that this information applies to your equipment. If you have any questions regarding this information please visit our website at www.prestolite.com, or contact our technical service department at:

Date: July 18, 2008

Bulletin No: TSB-1105

Installing rotor into front housing:

Step 32: Press rotor into front housing. (Fig 37)

Note: When pressing rotor support front housing as close to the bearing as possible to prevent damage to the front housing.

Use caution not to damage slip ring when pressing rotor into front housing.

Step 33: Slide spacer onto shaft. (Fig 38)

Step 34: Slide felt and steel washer on shaft. (Fig 39)

To assemble the alternator please refer to TSB-1068.

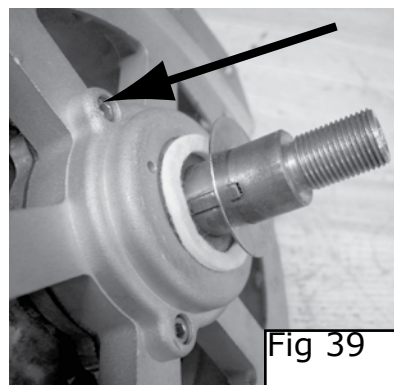
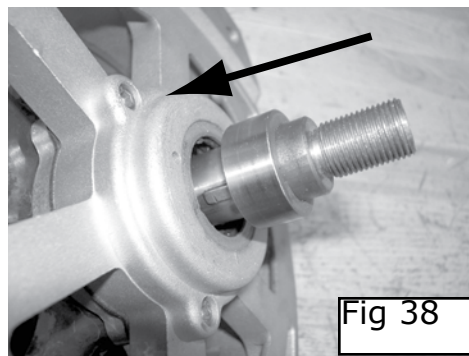
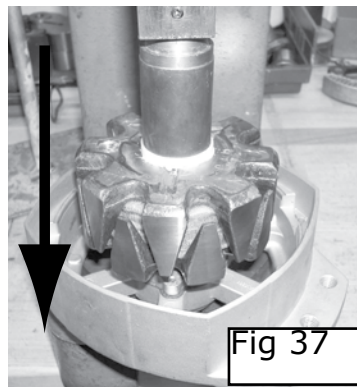

Important: The information contained in this bulletin is intended for use by trained, professional technicians who have the proper tools, equipment, and training to perform the required maintenance described above. This information is NOT intended for 'do-it-yourselfers', and you should not assume that this information applies to your equipment. If you have any questions regarding this information please visit our website at www.prestolite.com, or contact our technical service department at:

Technical specifications: TM55 / TM65



Benefits for Bus and Coach Operators

- Best efficiency
- Reliability & durability
- High cooling capacity

Benefits for Bus Makers

- Lightweight and compact
- Balanced 14 cylinders design
- Excellent performance-cost ratio

Benefits for A/C System Makers

- Perfect compatibility
- Premium quality product
- Valeo warranty and competitive pricing



Model	TM55	TM65
Technology	Heavy Duty Swash Plate	Heavy Duty Swash Plate
Displacement	550 cm ³ / rev	635 cm ³ / rev
Number of cylinders	14 (7 double-headed pistons)	14 (7 double-headed pistons)
Revolution range	600 – 4000 rpm	600 – 4000 rpm
Direction of rotation	Clockwise (viewed from clutch)	Clockwise (viewed from clutch)
Refrigerant	HFC-134a	HFC-134a
Bore	38.5 mm	38.5 mm
Stroke	33.7 mm	38.9 mm
Lubrication system	Gear pump	Gear pump
Shaft seal	Lip seal type	Lip seal type
Oil	ZXL100PG PAG OIL (1500 cm ³) or POE option	ZXL100PG PAG OIL (1500 cm ³) or POE option
Weight	18.1 kg (w/o clutch)	18.1 kg (w/o clutch)
Dimensions	354 – 194 – 294 mm (w/ clutch)	354 – 194 – 294 mm (w/ clutch)
Mounting	Direct (side or base)	Direct (side or base)

TECHNICAL DRAWINGS

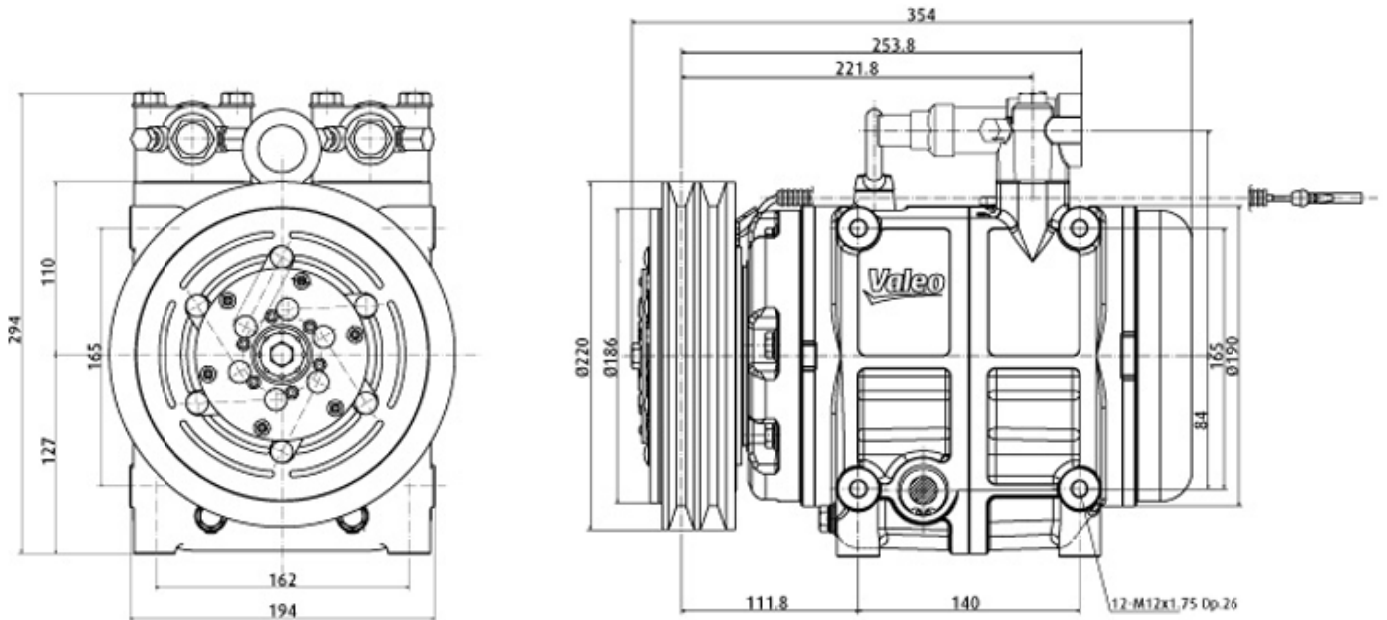

PERFORMANCE CURVES

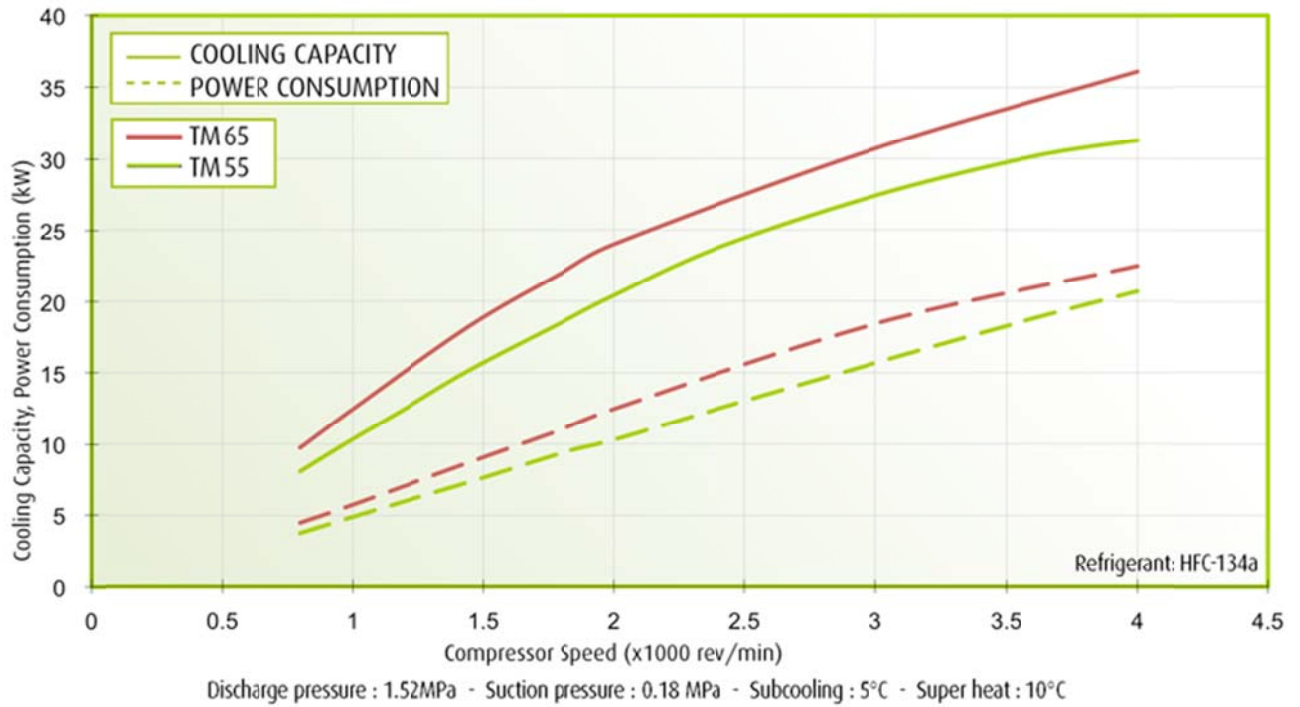

OPERATION MAP

Valeo TM55 / TM65 Application limits (R134a)

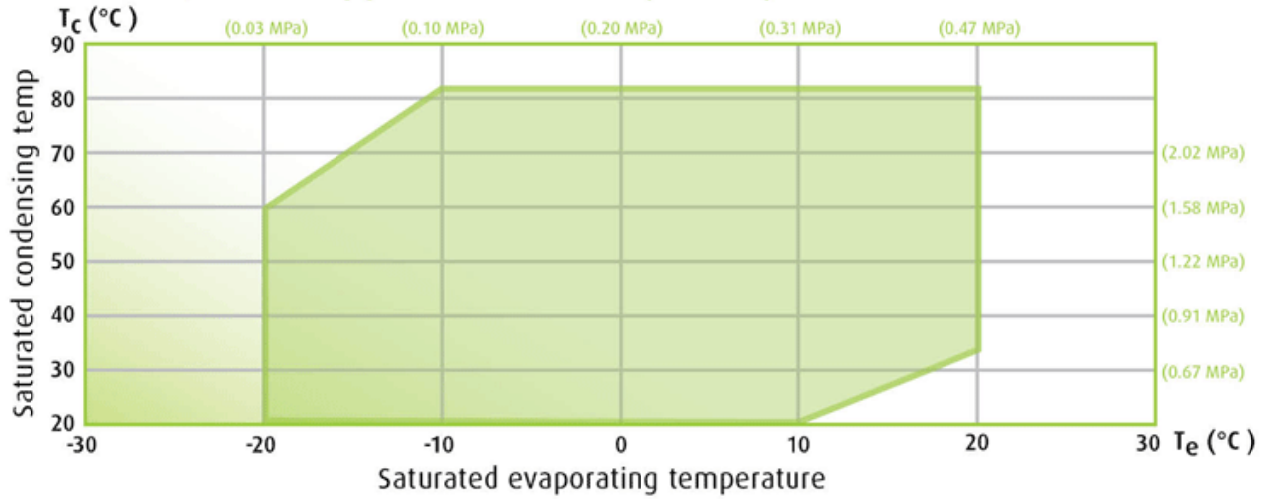

T_c : Saturated condensing temperature (°C)
 T_e : Saturated evaporating temperature (°C)

MAGNETIC CLUTCH VARIATIONS

BW220 AW260

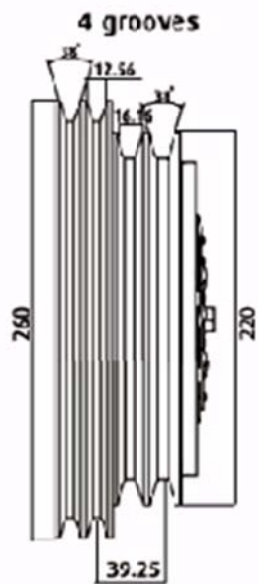

BW220 AW250

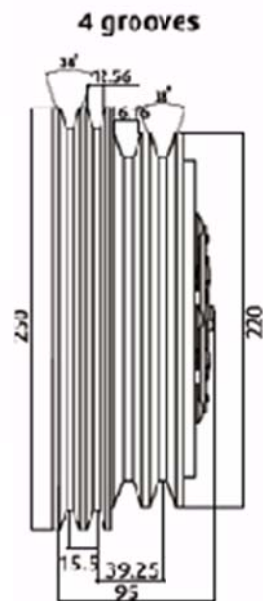

BW220

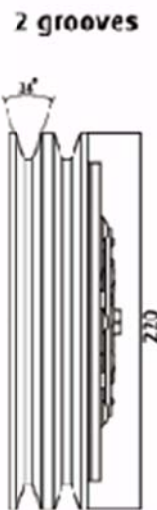

PK196



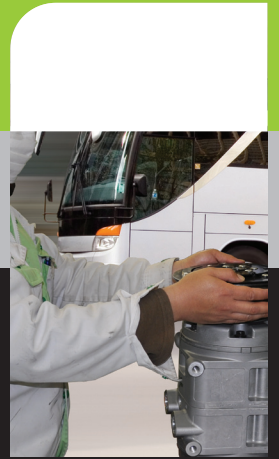

SERVICE MANUAL

Valeo TM55 & TM65 Compressors



valeo added 

Copyright © 2013 Valeo Japan Co, LTD. All rights reserved.

Valeo
Automotive technology, naturally

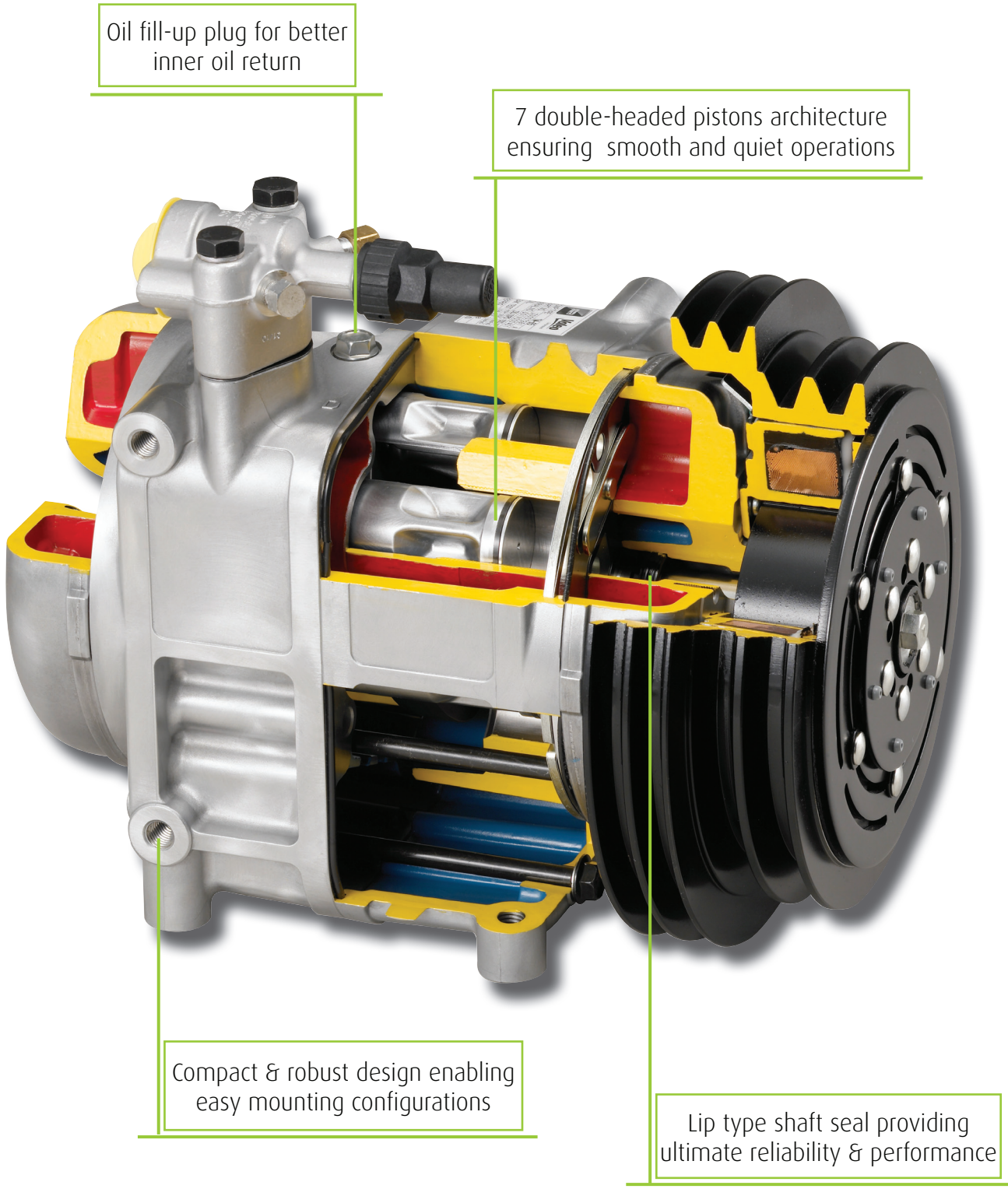

Oil fill-up plug for better inner oil return

7 double-headed pistons architecture ensuring smooth and quiet operations

Compact & robust design enabling easy mounting configurations

Lip type shaft seal providing ultimate reliability & performance

Light & Compact, Ultimate Reliability, Highest Performance

valeo added ■■■■■■

Foreword

This service manual has been elaborated to help service personnel to provide efficient and correct service and maintenance on the Valeo **TM55** and **TM65** compressors for bus air conditioning.

This manual includes the operation specifications, procedures for disassembly, reassembly, and inspection of the compressor.

The contents of the manual, including illustrations, drawings and specifications were the latest available at the time of printing.

The right is reserved to make changes in specifications and procedures at any time without notice.

VALEO JAPAN CO., LTD.

WARNINGS

The following warning signs are used in this service manual. These are extremely important to ensure safe operation and to prevent body injuries and property damage. They must be fully understood before starting the air conditioner maintenance.

WARNING! Maintenance must be properly done to avoid serious injury risks.

CAUTION! Improper maintenance can result in injury or proper damage.

MEANING OF MARKS

The following marks are used in this service manual to facilitate correct air conditioner maintenance.

Advice Procedures necessary to ensure the best air conditioner maintenance.

Note Information to optimize the air conditioning maintenance.

Contents

1- Product description.....	3
Compressor speed (rpm)	7
Conversion factors	7
2- Operation precautions	15
3- Handling instructions.....	16
Maintenance precautions	16
Work area.....	16
Refrigerant handling	16
Compressor handling.....	17
Compressor removal.....	17
Oil return operation	18
Oil handling.....	18
Oil level at inclination conditions.....	19
Front Lifting.....	19
Lateral Inclination	19
Oil contamination	20
Oil check.....	20
Replacement of components	21
Running-in operation.....	22
Compressor running-in.....	22
Magnetic clutch running-in.....	22
Leak test.....	23
Storing a repaired compressor	23
4- Troubleshooting	24
Compressor troubleshooting.....	24
Compressor troubleshooting tree.....	24
A/C cycle diagnosis by gauge pressure	27
5- Tightening torques.....	29
6- Service procedures - Magnetic clutch.....	30
7- Service procedures - Shaft seal assembly.....	36
8- Service procedures - Cylinder heads.....	39
9- Service tools.....	43
10- Service parts	53

1- Product description - Compressor

Compressor

MODEL	TM55	TM65
TECHNOLOGY	Heavy Duty Swash Plate	
DISPLACEMENT	550 cc / 33.56 in ³ per rev.	635cc / 38.75 in ³ per rev.
NUMBER OF CYLINDERS	14 (7 double-headed pistons)	
REVOLUTION RANGE	600-4000 rpm	
DIRECTION OF ROTATION	Clockwise viewed from clutch	
BORE	38.5 mm (1.52 in)	
STROKE	33.7 mm (1.30 in)	38.9 mm (1.53 in)
SHAFT SEAL	Lip seal type	
LUBRICATION SYSTEM	Lubrication by gear pump	
REFRIGERANT	HFC-134a	
OIL (QUANTITY)	ZXL 100PG PAG OIL (1500 cc/0.40 gal) or POE option	
CONNECTIONS Internal Hose Diameter	Suction: 35 mm (1-3/8 in) Discharge: 28 mm (1-1/8 in)	Suction: 35 mm (1-3/8 in) Discharge: 35 mm (1-3/8 in)
WEIGHT	18.1kg / 39.9 lbs (w/o Clutch)	
DIMENSIONS Length - Width - Height	341 - 194 - 294 (mm) 13.4 - 7.64 - 9.33 (in)	
MOUNTING	Direct (side or base)	

Valeo **TM55 & TM65** Application limits

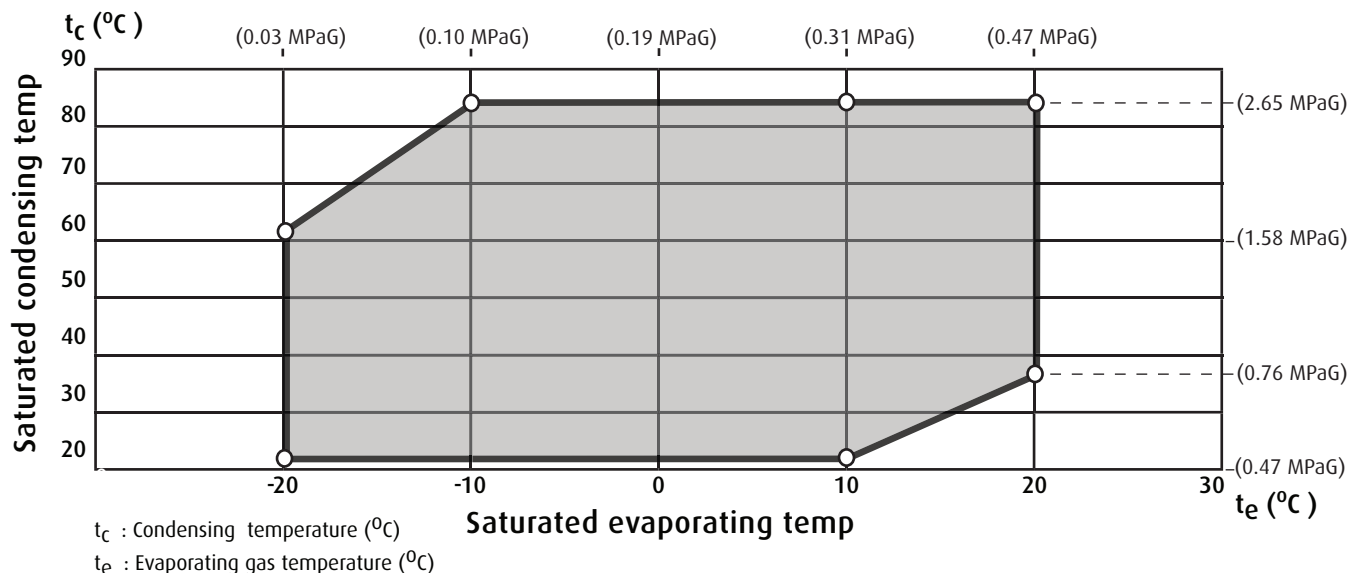

1- Product description - Compressor

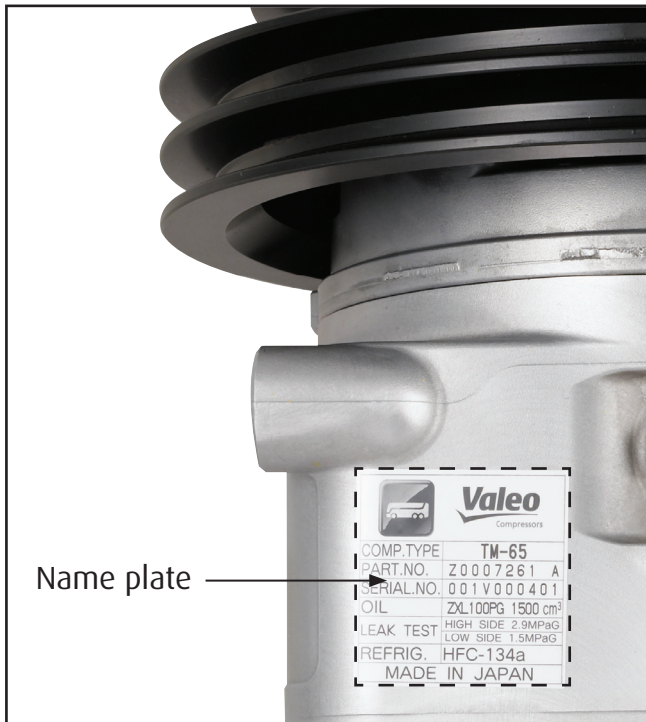

Name plate

To ensure that the compressor operates smoothly, be careful to respect the indications written on the name plate located on top of the compressor body.

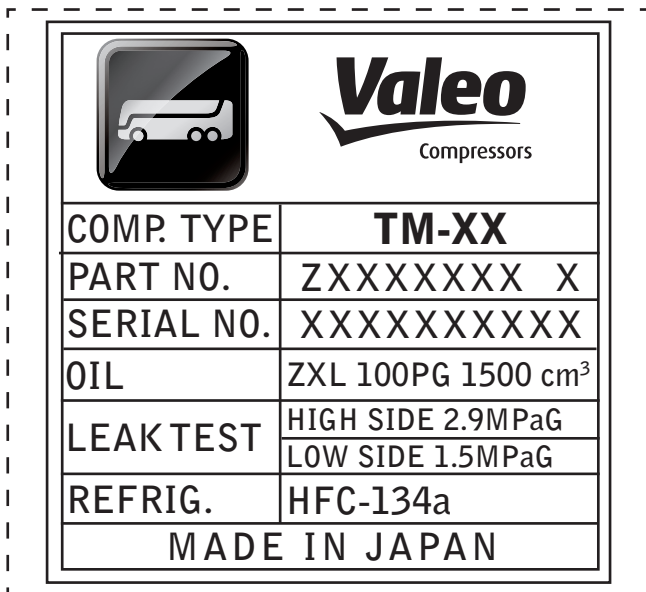

Tip

As **TM55 & TM65** compressors have the same dimensions, the best way to differentiate them quickly is by referring to the name plate.

1- Product description - Magnetic clutch

Magnetic clutch

VALEO **TM55 & TM65** are available either as a compressor and magnetic clutch assembly or as a compressor body that customers can fit with compatible magnetic clutches. The magnetic clutch design Valeo has been promoting for more than 20 years is now gradually adopted by major market actors.

Our compressors and magnetic clutches have successfully passed the thousand hours of long validation tests in Valeo Compressors research center laboratory. Operational excellence was demonstrated during hot season testing on field under challenging climates in the most stressful conditions.

Being able to rely on our robust magnetic clutch provides the best way to reduce fuel consumption without using additional unloading devices that decrease significantly the efficiency and durability of the compressor. The range of Valeo magnetic clutches ensures an unmatched reliability and the longest durability that perfectly matches the Valeo **TM55 & TM65** compressor qualities.

Specifications*

TECHNOLOGY	Electromagnetic single-plate dry clutch
RATED VOLTAGE	24V DC or 12V DC
CURRENT CONSUMPTION	50 W maximum
STATIC TORQUE	250 N·m {25.5 kgf·m, 184 lbf·ft}
DIRECTION OF ROTATION	Clockwise viewed from clutch
WEIGHT	Approx 10~12 kg {22-27 lbs}
V-BELT TYPE	V-groove (A or B) or V-ribbed (PK)

*The specifications may vary with the compressor.

Please also note that the maintenance procedures introduced in this service manual apply only to magnetic clutches provided by Valeo.

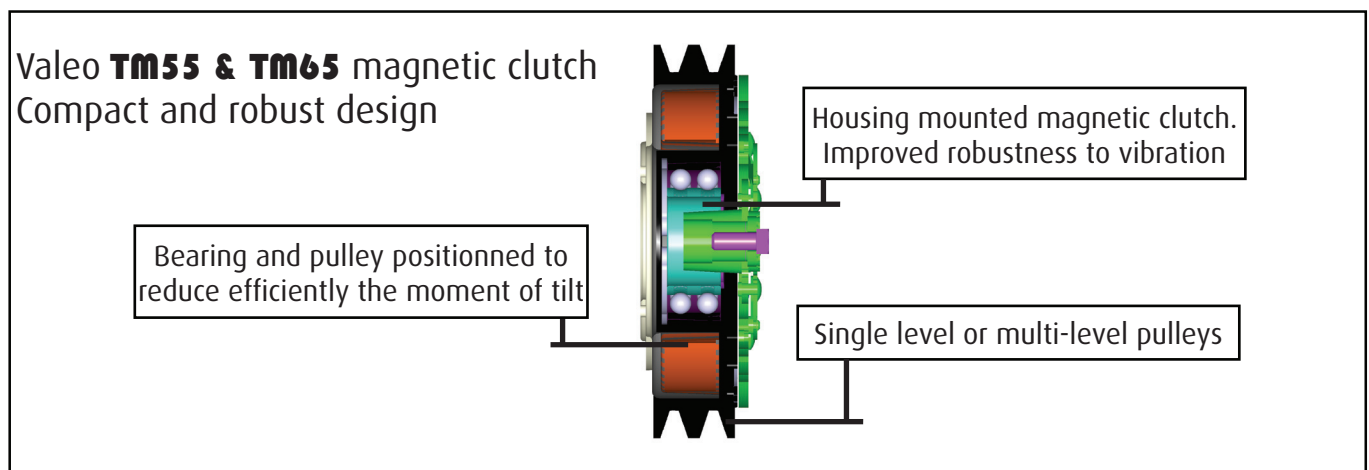

1- Product description - Connectors

Connectors

1. Fully open the shut-off valve when operating the compressor

- Unscrew the cap.
- Loosen the valve spindle seal by $\frac{1}{4}$ turn.
- Turn the spindle in the counterclockwise direction until it stops.

The shut-off valve is now fully opened and the service port connector is closed.

- When finished, tighten the valve spindle seal carefully and screw the cap.

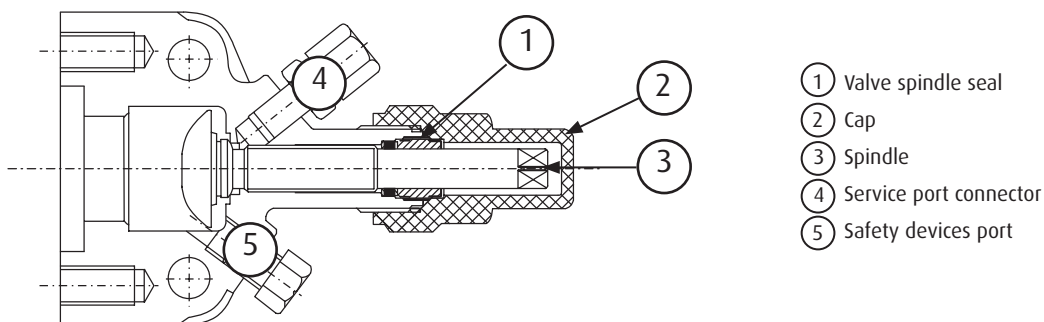

2. Open the service port connector when using a gauge manifold

- Turn the spindle in the clockwise direction by $\frac{1}{2}$ turn to 1 turn.

The shut-off valve and the service port connector are now opened.

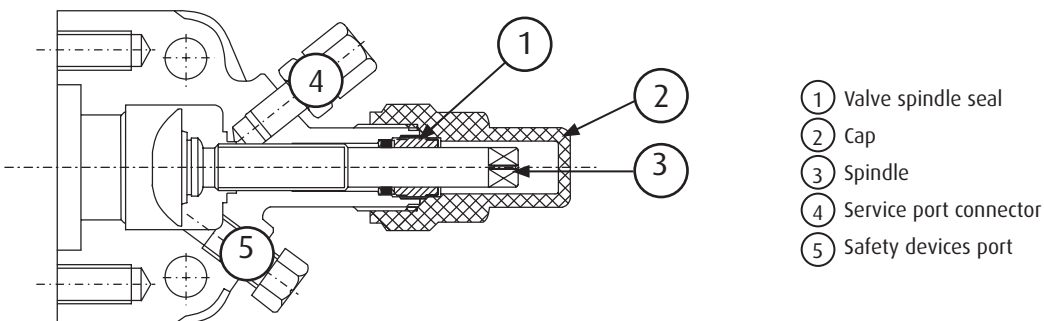

3. Fully close the shut-off valve when removing the compressor

- Turn the spindle in the clockwise direction until it stops.

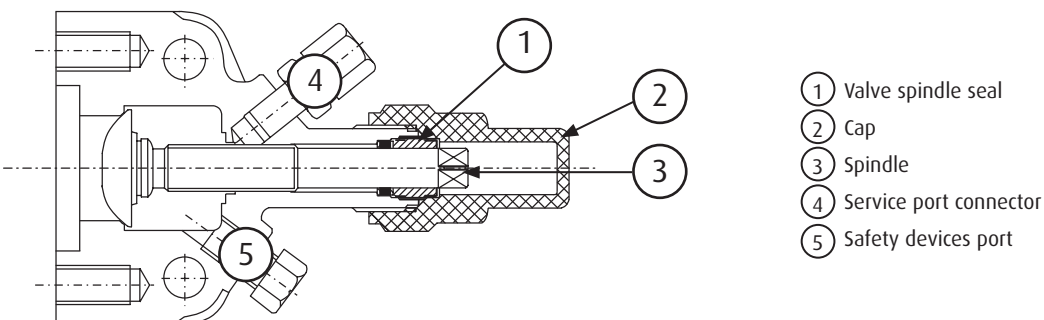

1- Product description - Performance

The performance data below were measured under the following conditions:

- Compressor speed: 1450 rpm
- Suction gas temperature: 20°C

Valeo **TM-55** performance data (R134a)

Conditions			Cooling Capacity Q and Power Consumption P					
Cond. temp (°C)	Pd (MPaG)	Evap temp (°C)	-10	-5	0	5	10	12.5
		Ps (MPaG)	0.10	0.15	0.19	0.24	0.32	0.35
40	0.91	Q (kW)	14.73	19.68	23.88	29.30	37.23	40.31
		P (kW)	5.31	5.96	6.39	6.77	7.21	7.36
50	1.21	Q (kW)	12.75	17.52	21.06	25.58	32.97	35.54
		P (kW)	5.80	6.59	7.09	7.63	8.32	8.48
60	1.58	Q (kW)	10.53	14.42	17.60	21.39	28.16	30.65
		P (kW)	6.28	7.21	7.84	8.52	9.38	9.63

Valeo **TM-65** performance data (R134a)

Conditions			Cooling Capacity Q and Power Consumption P					
Cond. temp (°C)	Pd (MPaG)	Evap temp (°C)	-10	-5	0	5	10	12.5
		Ps (MPaG)	0.10	0.15	0.19	0.24	0.32	0.35
40	0.91	Q (kW)	17.29	22.96	28.21	33.92	42.18	45.71
		P (kW)	6.30	7.02	7.53	8.10	8.68	8.90
50	1.21	Q (kW)	15.16	20.21	24.24	29.31	37.58	40.37
		P (kW)	6.83	7.76	8.39	9.06	9.90	10.11
60	1.58	Q (kW)	12.66	17.30	20.80	25.28	32.10	34.56
		P (kW)	7.35	8.43	9.17	9.95	11.02	11.35

Valeo **TM55 & TM65** conversion factors

The performance data at different rotation speed can be approximated with the conversion factors below.

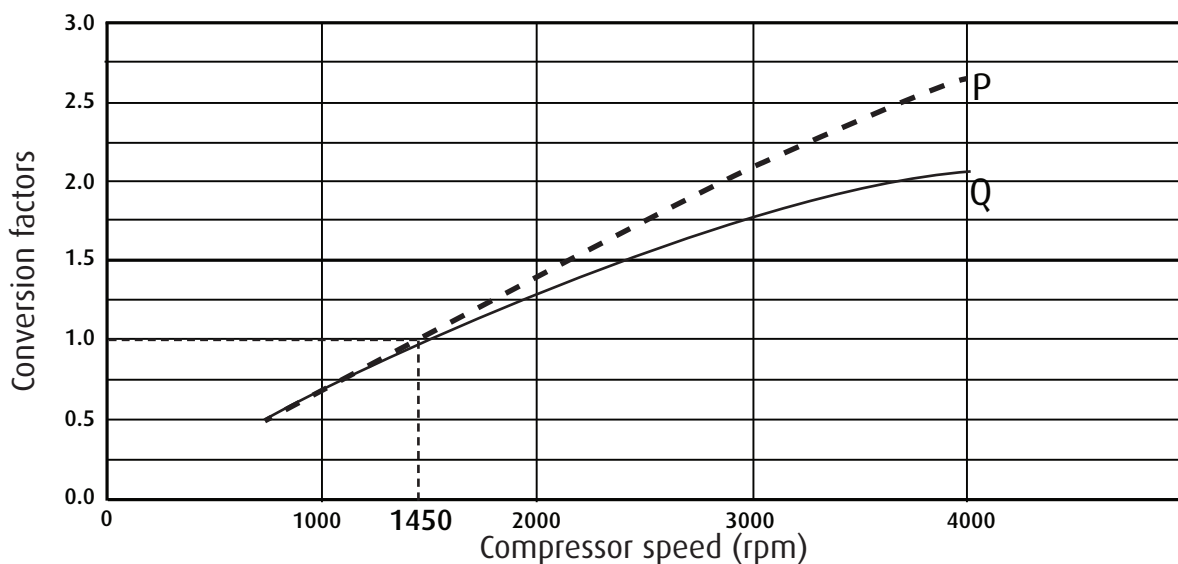

1- Product description - Dimensions

TM55 & TM65 compressors with magnetic clutch

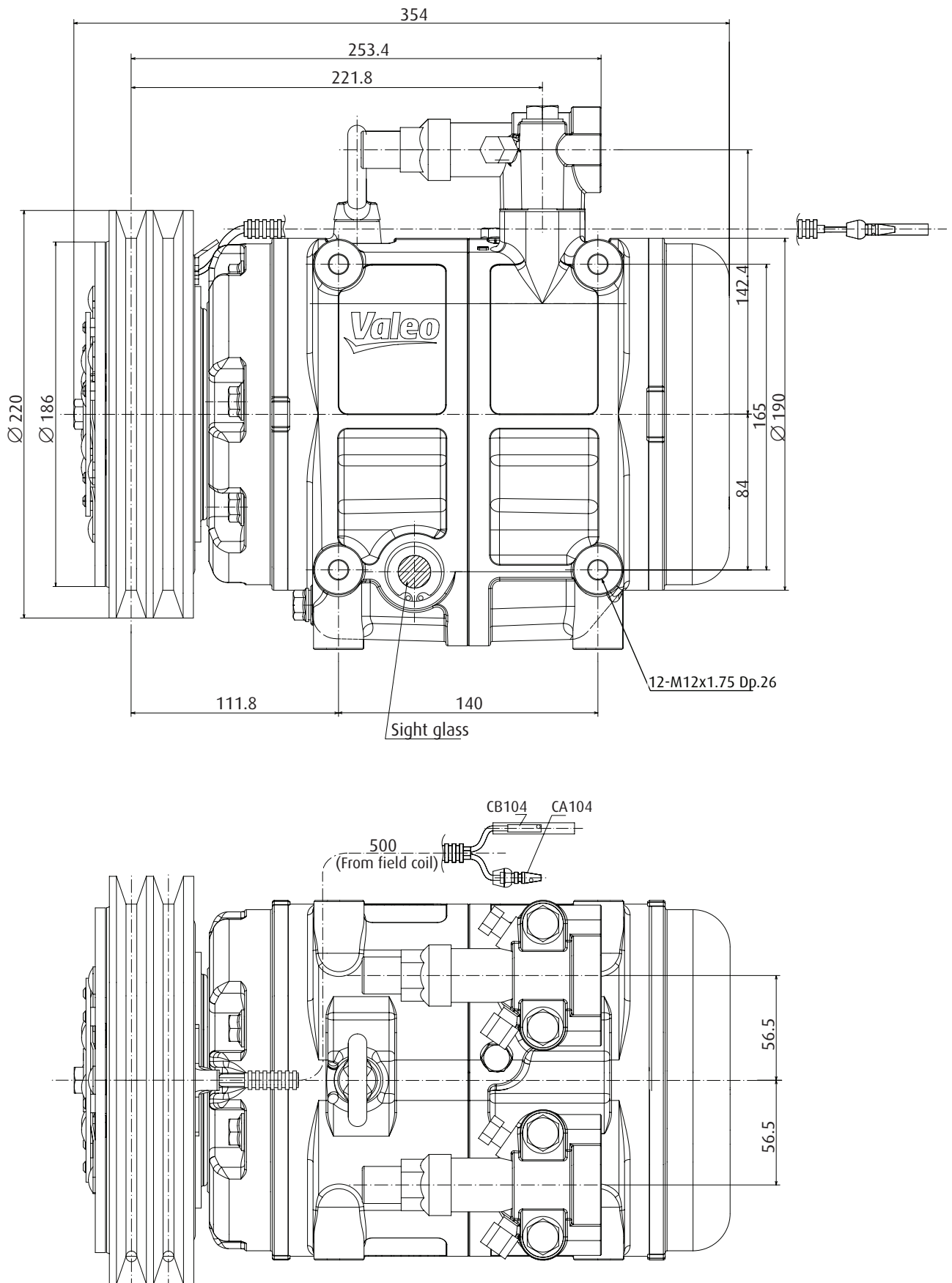

1-Product description - Dimensions

TM55 & TM65 compressors without magnetic clutch

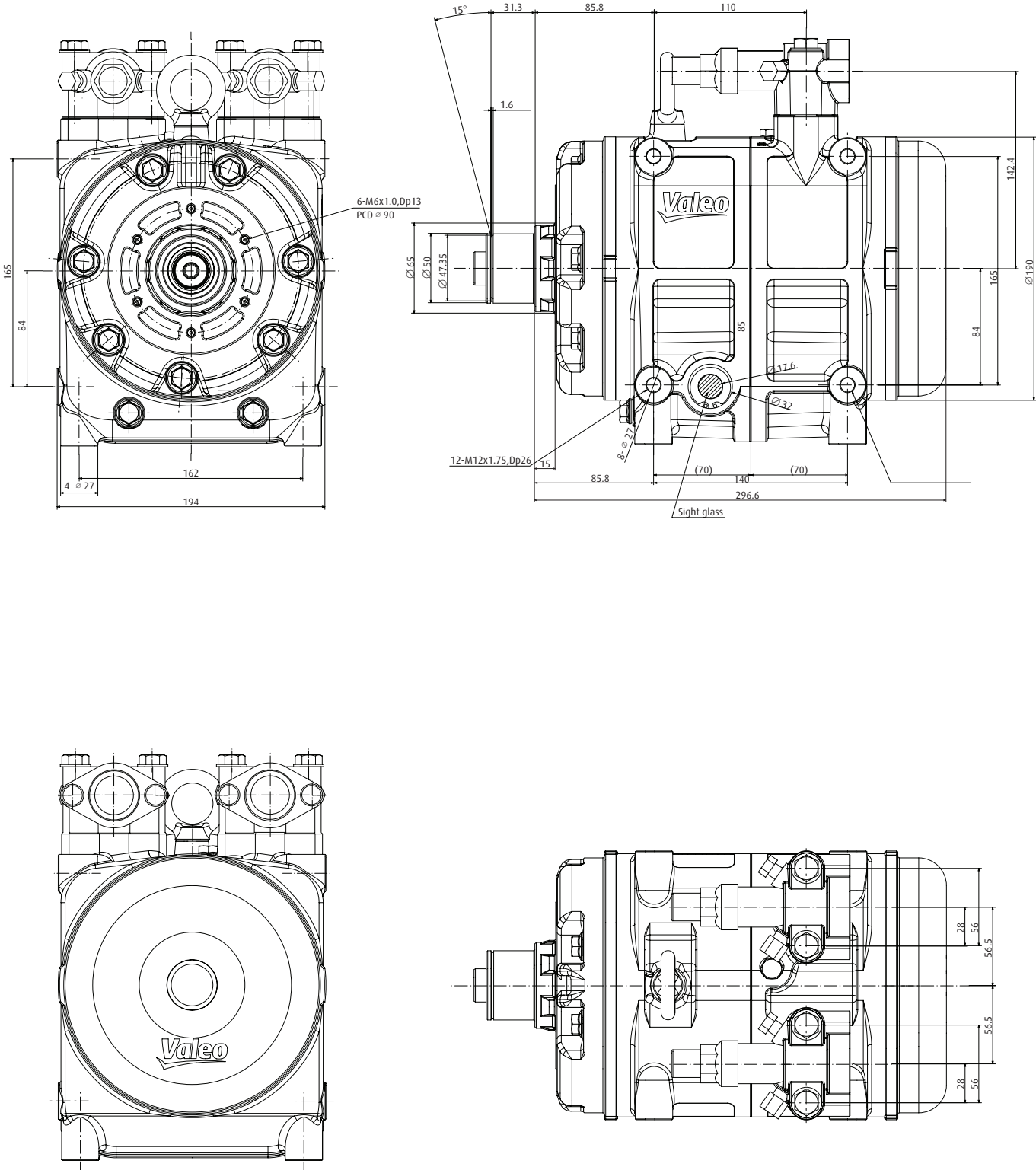

1- Product description - Exploded view

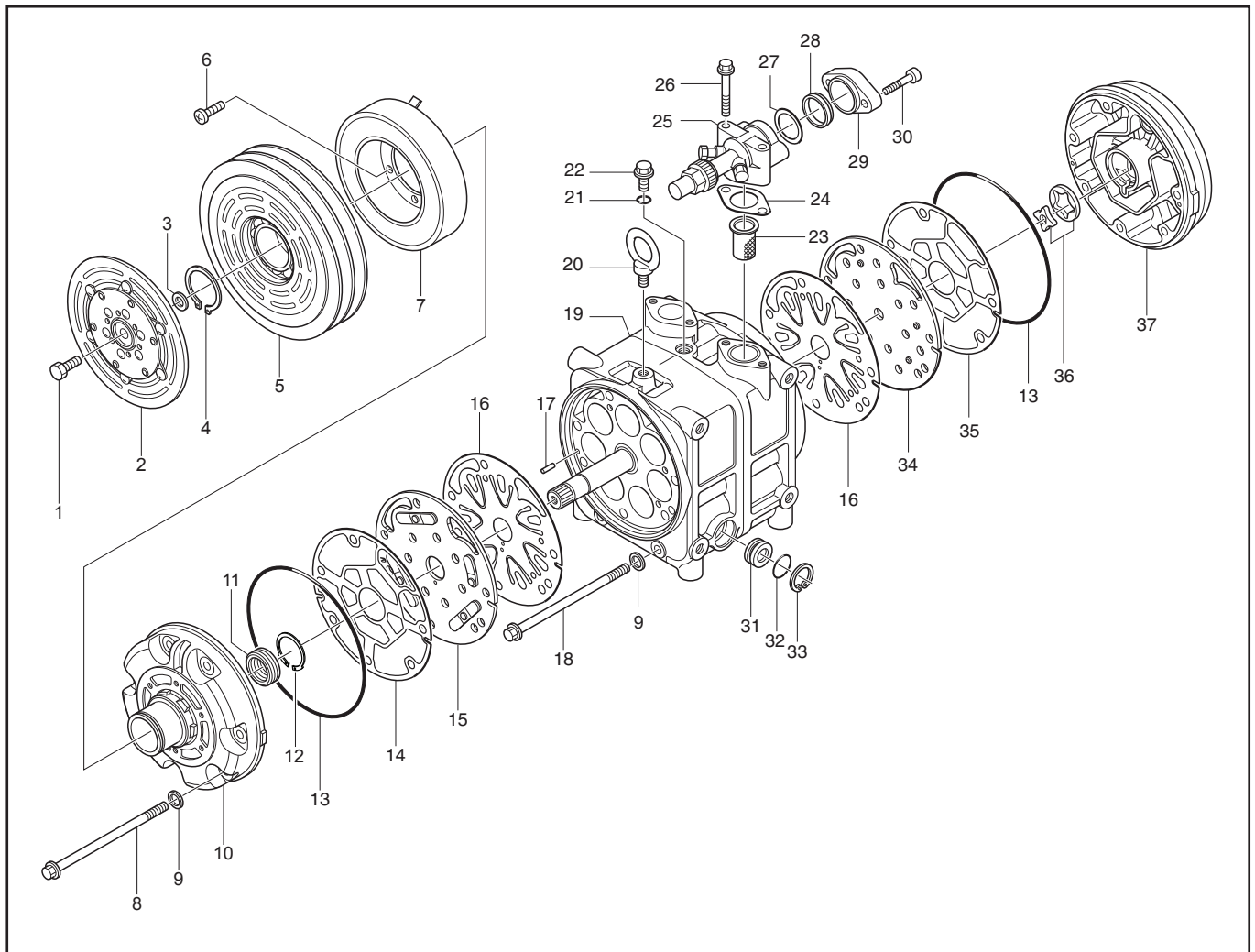

1. Center bolt
2. Armature assembly
3. Adjusting shim
4. Snap ring
5. Pulley assembly
6. Screw
7. Field coil
8. Bolt
9. Gasket
10. Front cylinder head
11. Shaft seal assembly
12. Snap ring
13. O-Ring
14. Gasket
15. Valve plate assembly
16. Suction valve
17. Pin
18. Bolt
19. Cylinder shaft assembly

20. Eye bolt
21. O-Ring
22. Oil filler plug
23. Strainer
24. Gasket
25. Connector
26. Bolt
27. Gasket
28. Plate
29. Plate
30. Bolt
31. Sight glass
32. O-ring
33. Snap ring
34. Valve plate assembly
35. Gasket
36. Gear pump
37. Rear cylinder head

1- Product description - Swash plate system

Valeo **TM55 & TM65** are 14 cylinder swash plate type compressors. With this type of compressor, the cylinders and pistons are arranged axially along the drive shaft.

The pistons operate within the cylinders and are driven by a swash plate to perform suction, compression and discharge.

Swash plate system

The drive shaft, which is driven by the engine through the magnetic clutch, is equipped with a swash plate.

The drive shaft is supported by two radial bearings and two thrust bearings.

The swash plate is rotated by the drive shaft, and moves the pistons back and forth.

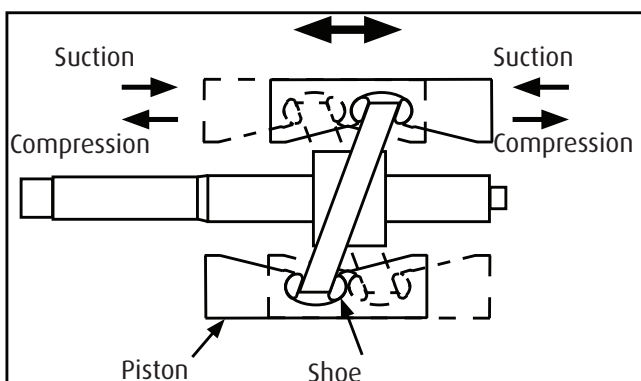
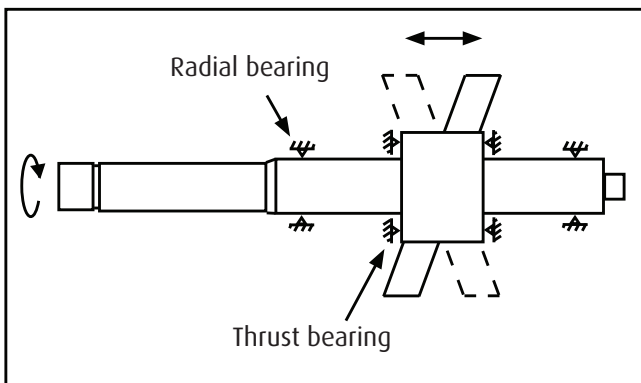
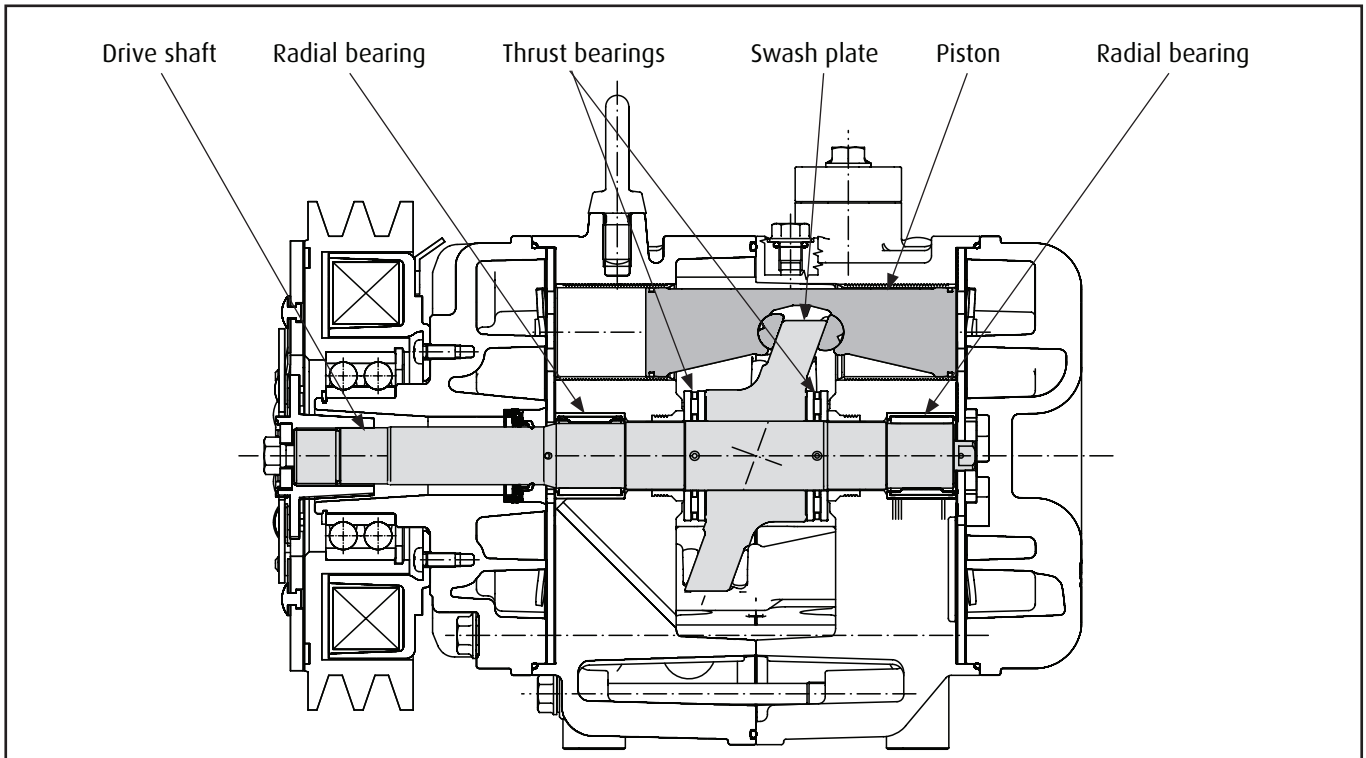

Piston Drive System

The pistons in the cylinders are mounted on the swash plate through hemispherical shoes.

Each piston has a compression head at each end. Swash plate rotation results in a reciprocating piston movement horizontal to the drive shaft.

The cylinders, which are arranged at 51.4° intervals around the drive shaft, are each divided into 2 chambers, providing 7 front and 7 rear bores.

As each piston performs suction and compression at either end, the compressor operates as a 14 cylinder compressor.

1- Product description - Lubrication

The gear pump situated at the end of the drive shaft draws oil from the oil reservoir and lubricates the parts of the compressor.

Oil flow

When the compressors start operating, the gear pump draws oil from the reservoir and pumps it through an oil passage in the shaft.

The oil then flows through ports in the shaft to lubricate the bearings and the shaft seal.

The area between the swash plate and the shoes is lubricated by the splashing action of the oil flowing through the thrust bearings.

The compressor remains constantly lubricated thanks to the oil circulating together with the refrigerant. Valeo compressor innovative internal design ensures that almost no oil remains mixed with the refrigerant that is flushed into the air conditioning system.

Refrigerant itself plays a lubricant role to prevent the compressor to be damaged in case of oil shortage.

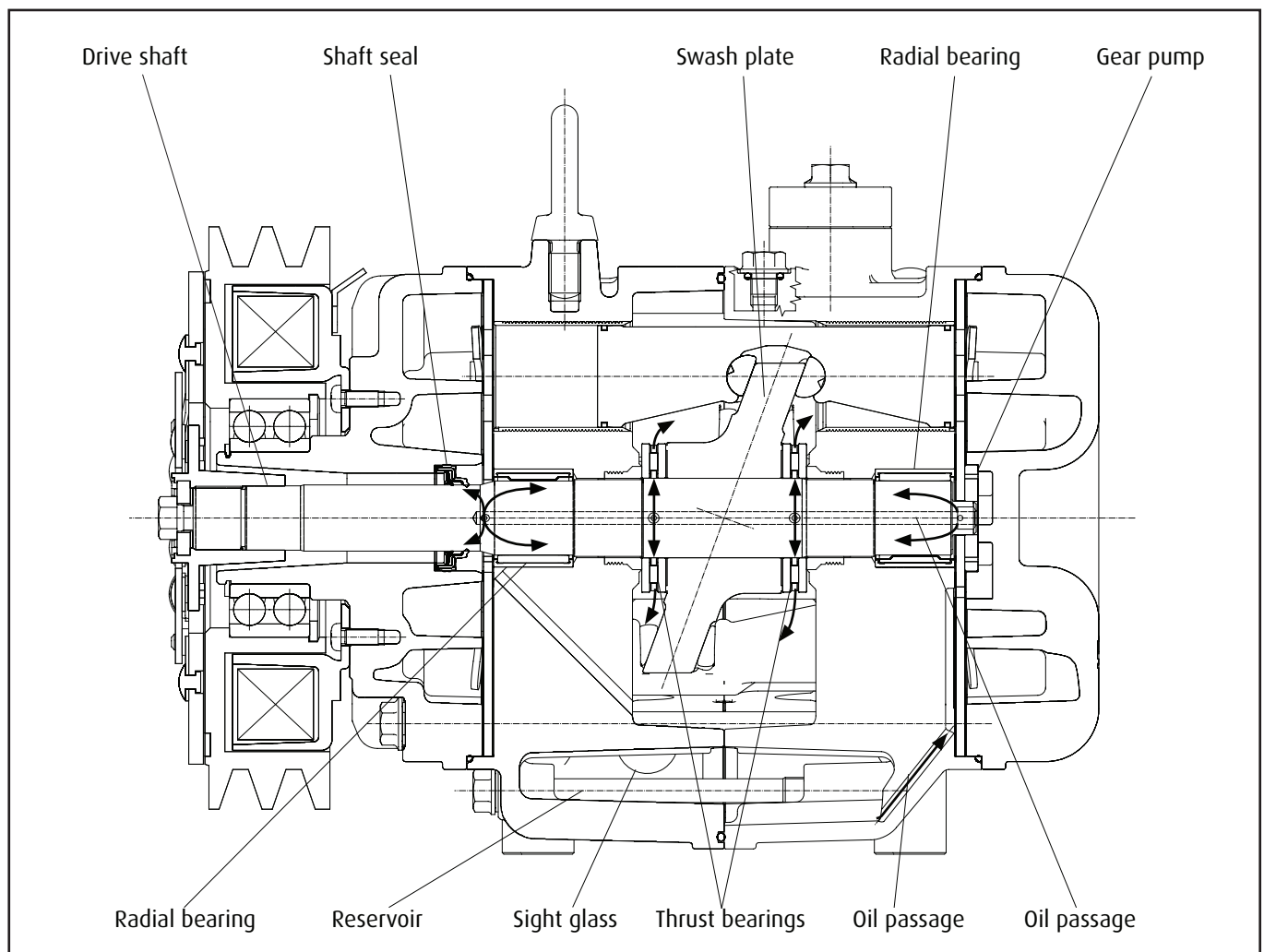

1- Product description

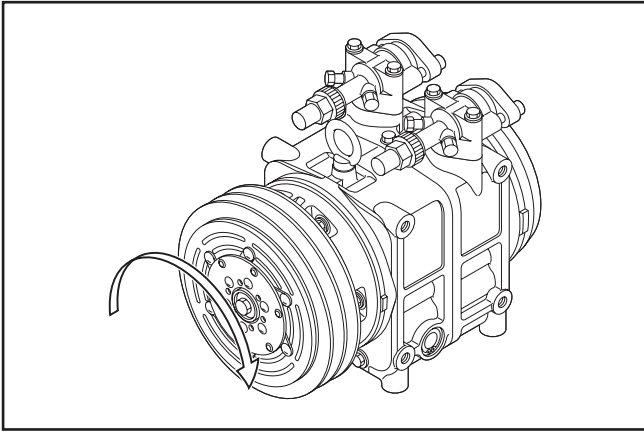

Compressor

1. The direction of rotation is clockwise as viewed from the clutch side.
2. The standard compressor oil charge is specified for bus air conditioners. The oil quantity may differ depending on the type and use of compressor. Please refer to the label on the compressor.

Operation condition table

Item	Condition
Surrounding temperature	Under 120°C (248°F)
Speed	Minimum: 600 r/min Maximum: 4500 r/min Continuous: 4000 r/min
Pressure	Maximum: 2.65 MPaG {28kgf/cm ² , 385 psig}

3. The compressor must be operated under the conditions shown in the operation condition table shown at left.

CAUTION!

The A/C cycle components must be designed so that the pressure in the cycle does not exceed 2.65 MPaG {28 kgf/cm², 385 psig}

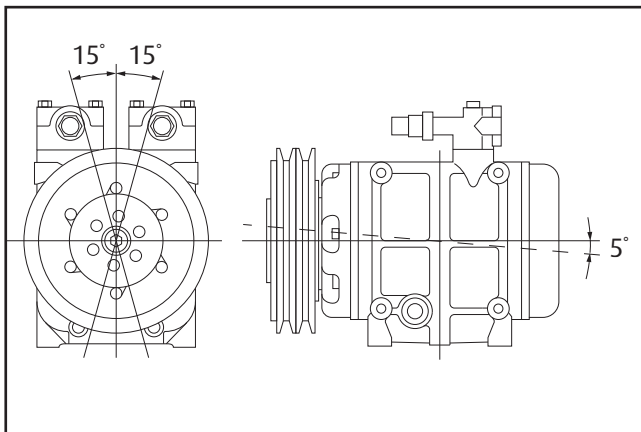

4. Inclination limit at installation
The compressor must be installed on the vehicle within the range shown at left.
Front head forward leaning is prohibited.

Compressor mounting points

The compressor's mounting points should be tightened to the specified torque:

Specified torque: 45 - 50 N·m
{4.6 - 5.1 kgf·m, 33.2 - 36.9 lbf·ft}

Compressor bracket

1. Install the bracket securely on the chassis frame or engine body. As the engine vibrations may be severe, the bracket and mounting bolts must be installed securely.
2. Vibration resistance
There must not be any resonance under 250 HZ.

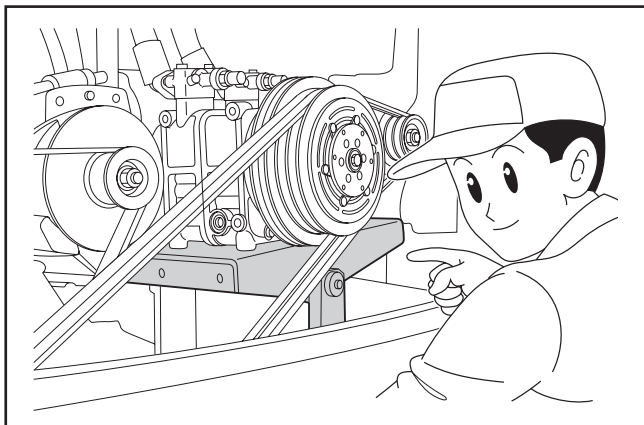

1- Product description

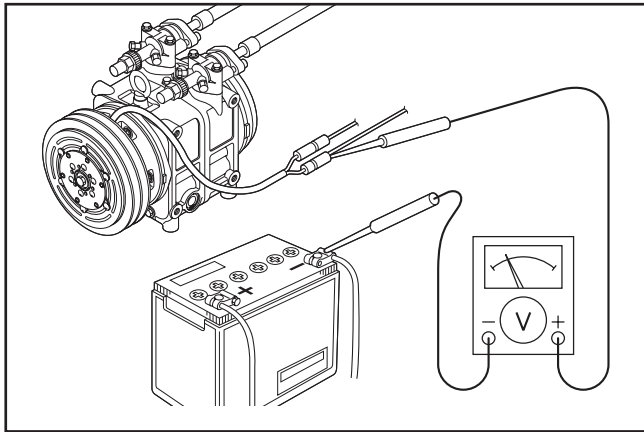

Magnetic clutch

1. Voltage

DC 24 V

The terminal voltage of the magnetic clutch must exceed 21 V.

DC 12 V

The terminal voltage of the magnetic clutch must exceed 10.5 V.

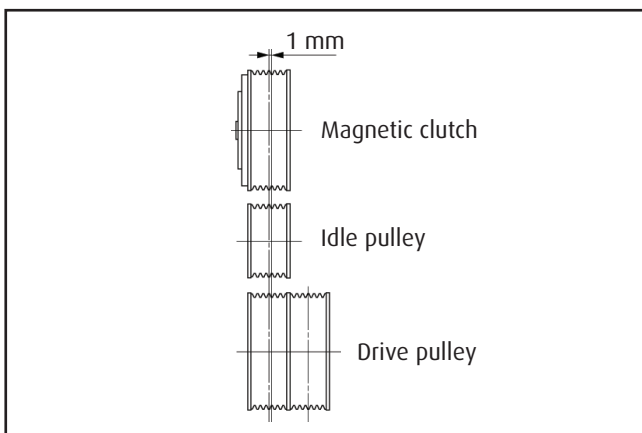

2. Ratio of magnetic Clutch to drive pulley

- When the compressor is driven from the pulley drive of the vehicle, the magnetic clutch to drive pulley ratio should avoid the range 1: 0.92~1.08 to limit vibration and resonance.
- Compressor speed must not exceed the specified speed.

CAUTION!

Pulley ratio is the ratio of the magnetic clutch diameter to the drive pulley diameter.

3. Pulley alignment tolerance is less than 1mm (0.04 in).
4. Pulley groove: V-groove or V-ribbed.
5. The V-belt tension must be adjusted to the tension specified by the belt maker.

2- Operation precautions

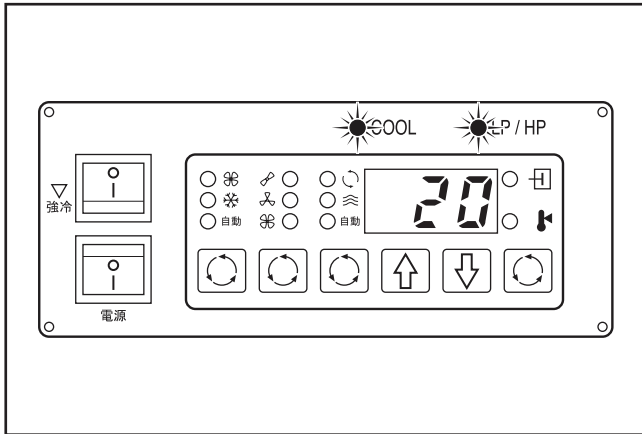

1. In the off season of air conditioner, operate the compressor for a few minutes from time to time.
2. Do not drive through water. Water may damage the magnetic clutch, thus preventing normal operation.
3. Always charge the A/C system with the specified quantity of refrigerant.

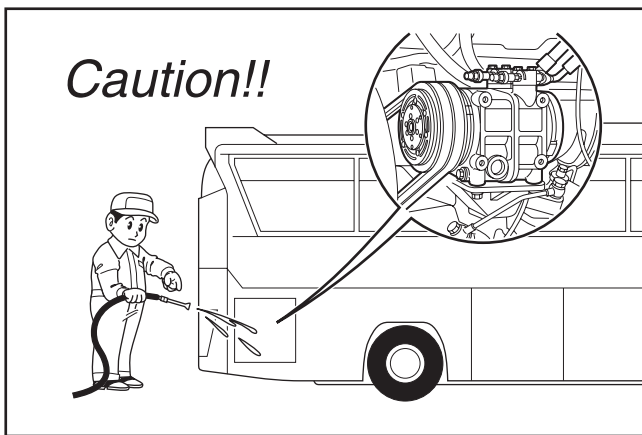

4. Keep the compressor clear of water projection while cleaning the vehicle.

3- Handling instructions

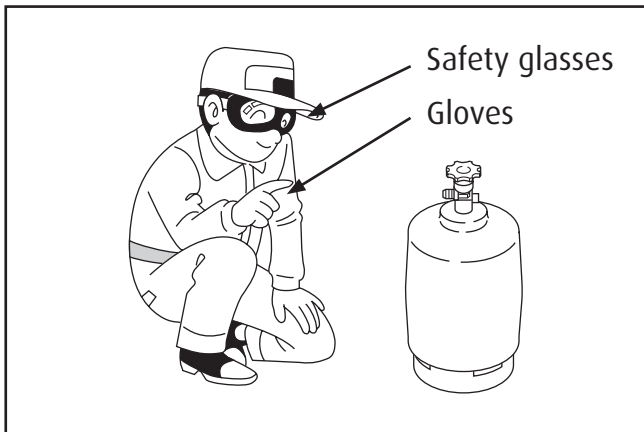
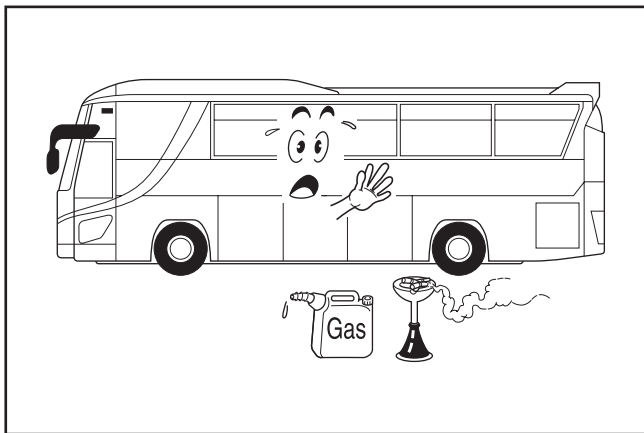
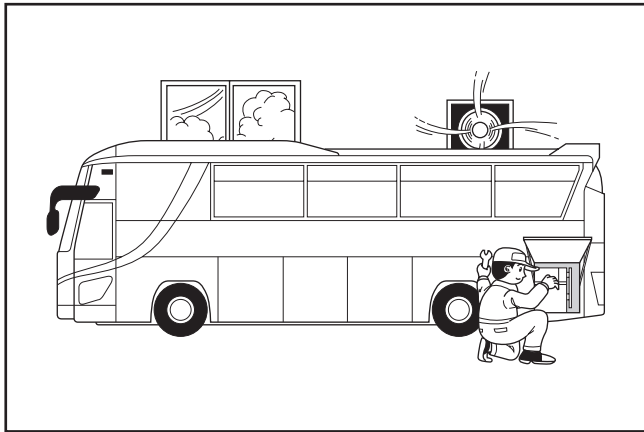

Maintenance precautions

Work area

Because the components of air conditioners are especially sensitive to moisture, dirt and rust, always observe the following:

- Work indoors whenever possible
- Select a flat ground work area
- Keep the work area clean
- Select a work area with adequate ventilation.

CAUTION!

Refrigerant itself is not harmful, but excessive accumulation in a closed area can cause oxygen deficiency.

- Keep naked flame and inflammable away from the vehicle in which the air conditioner is being installed.
(Fire is especially dangerous during the gas leak inspection following installation)

WARNING!

Contact with flame and high temperatures can generate toxic gases.

Refrigerant handling

WARNING!

Direct contact with refrigerant can cause frostbite or blindness.

Always wear safety glasses and protective gloves.

Do not work with refrigerant close to your face.

1. Do not mistake refrigerants

If an HFC-134a air conditioning system is mistakenly charged with another refrigerant, serious problems such as compressor seizing may occur. Therefore, confirm before charging with refrigerant that the type of air conditioning system is an HFC-134a system.

3- Handling instructions

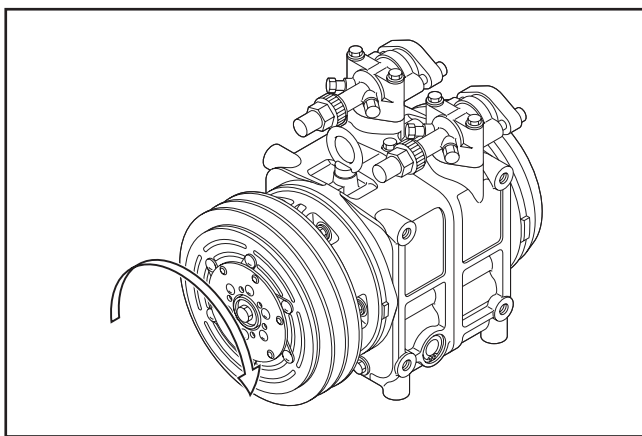
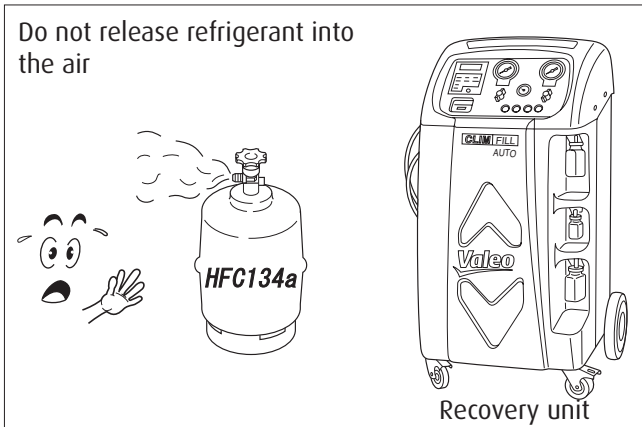

2. Do not release refrigerant into the air

Although HFC-134a is not subject to CFC regulations, it can have effect on global warming and so should not be released into the air. When removing refrigerant from the air conditioner system, always use a refrigerant recovery unit made especially for HFC-134a.

Compressor handling

Do not strike or unnecessarily turn the compressor upside down. If the compressor is knocked over or turned upside down during handling or installation, rotate the armature plate 5 or 6 times by hand to circulate the oil.

Otherwise, oil in the cylinder during compressor start-up will cause valve damage and reduce durability.

Compressor removal

When the compressor is operational

1. Perform the oil return operation (see p.18).
2. Recover the refrigerant from the system using a refrigerant recovery unit.
3. Remove the compressor.
4. Drain the oil from the compressor and close all open connections immediately.
5. Check the oil quantity and the degree of contamination (see p.19).

When the compressor is inoperable

1. Recover the refrigerant from the system using a refrigerant recovery unit if the shut-off valves are removed with the compressor.
2. Remove the compressor.
3. Drain the oil from the compressor and close all open connections immediately.
4. Check the oil quantity and the degree of contamination (see p.19).

3- Handling instructions

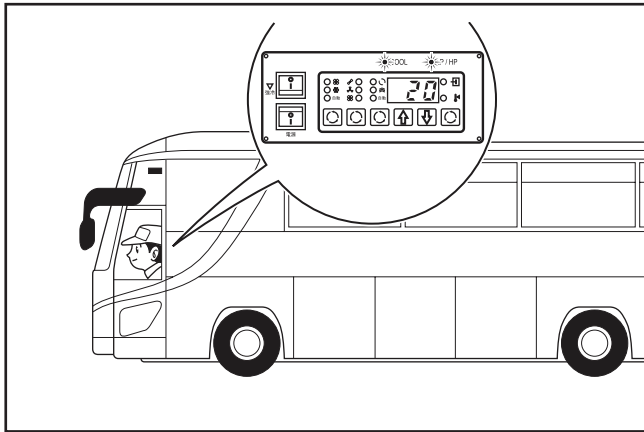

Oil return operation

Compressor oil mixed with refrigerant is circulating in the air conditioning system.

Perform the oil return operation to return this oil to the compressor before removing components from the system.

1. Open the doors and windows and operate the blower motor at maximum speed.
2. Operate the vehicle engine at idling during at least 20 minutes.

Note: The maximum amount of oil cannot be recovered at higher speeds. This operation also requires a warm ambient temperature.

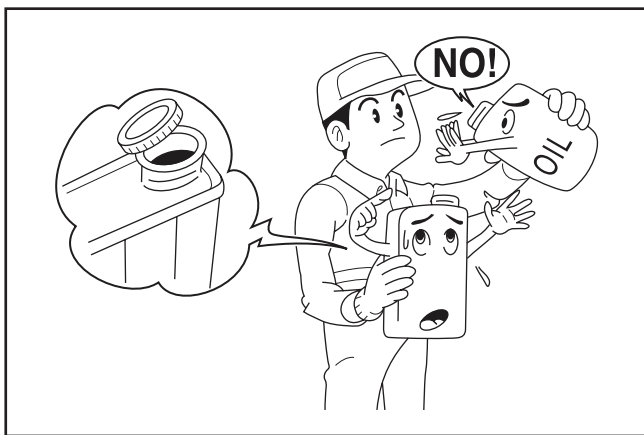

Oil handling

Oil specification

Use only ZXL 100PG (DH-PS) or POE oil.

Handling precautions

1. The oil must be free from dust, metal filings, etc.
2. Do not mix oils.
3. The moisture content must not exceed 1,000 ppm. (PAG oil only)
4. The oil easily absorbs moisture when the container is open. Therefore always seal the container immediately after use.

Oil quantity inspection

There is no particular need for frequent inspection or replacement, although it is recommended to check operating refrigerant pressures and oil levels at the start of the season.

Please replace the refrigerant and restore the system oil and refrigerant charge to factory specifications if:

- the AC system is opened for repair or replacement of any component (e.g.: evaporator, condenser or receiver drier)
- any loss of charge - refrigerant or oil - is detected.

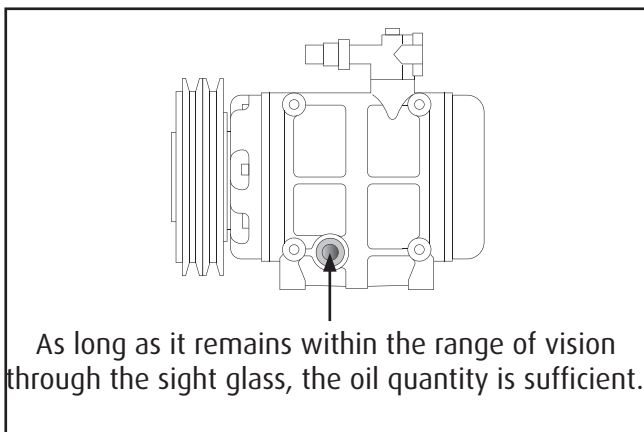

Oil level can be read through the sight glass of the compressor (see on the left).

3- Handling instructions

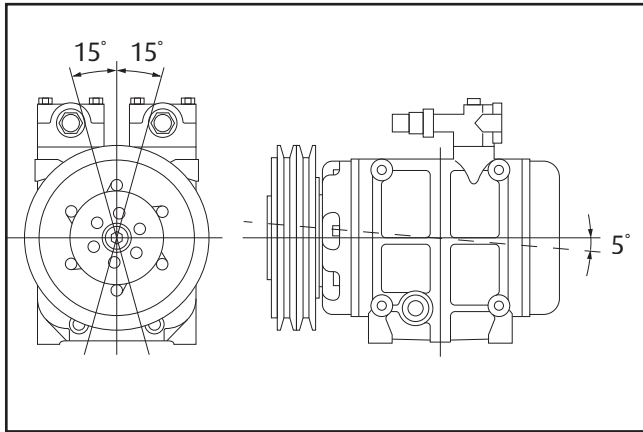

Oil level at inclination conditions

Compressor lateral inclination and front lifting at the same time are allowed so consider this factor during sight glass inspection (distorted indication).

Oil level inspection should be conducted at low compressor speed or compressor stopped. Sight glass cannot be used at high compressor speed because oil surface is not visible and a mixture of refrigerant and oil is formed.

A Flashlight can be helpful to expose oil surface: light up one of the sight glasses to read oil level at the opposite one.

CAUTION!

Be careful on rotating parts and high temperature parts.

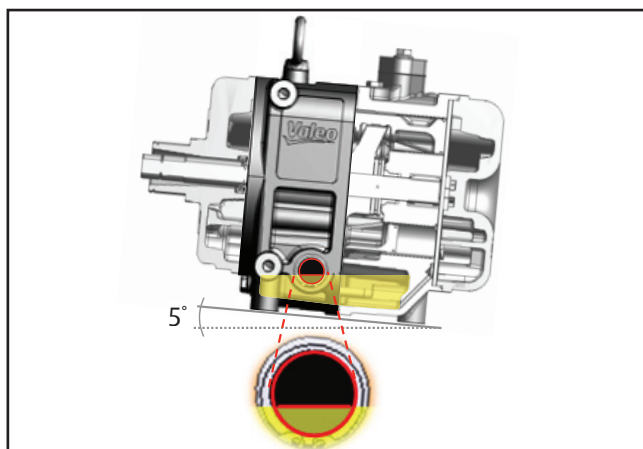

Front Lifting

In most of bus rear application, the front end of the compressor is lifted to fit the inclination of the engine.

1. Oil level at sight glass: oil level is distorted.
2. Oil amount: quantity appears lower than recommended but the level is actually correct, you do not need to add more oil.

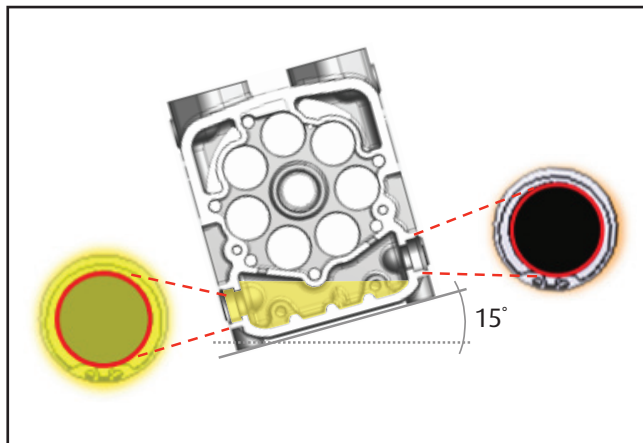

Lateral Inclination

1. Oil level at sight glass: one sight glass will look completely covered with oil while the other will look inferior to recommendation or even empty.
2. Oil amount: in this case, some of the oil is below oil passage level, therefore you should consider adding some oil to fill in the dead volume that appears in the illustration on the left.

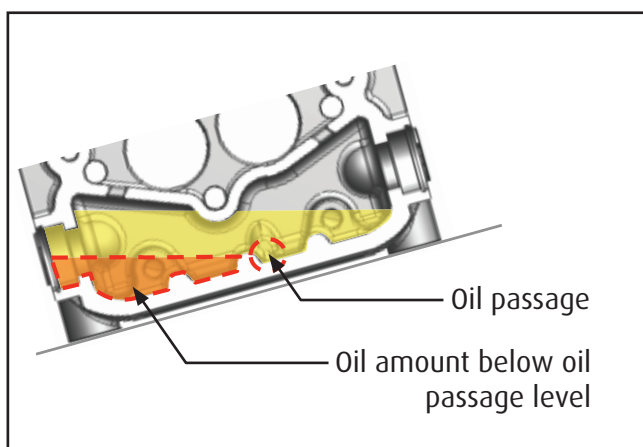

3- Handling instructions

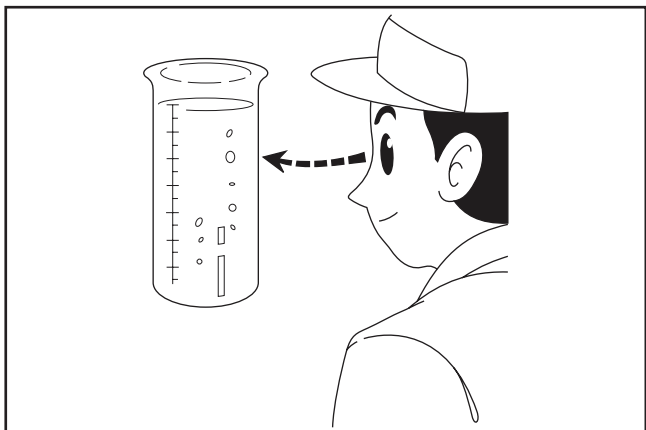

Oil contamination

Unlike engine oil, no cleaning agent is added to the compressor oil. Even if the compressor is run for a long time, the oil never becomes turbid as long as there is nothing wrong with the compressor or its method of use. Inspect the extracted oil for any of the following.

- Increased opacity of the oil.
- Color change to red
- Presence of foreign matter, metal filings, etc.

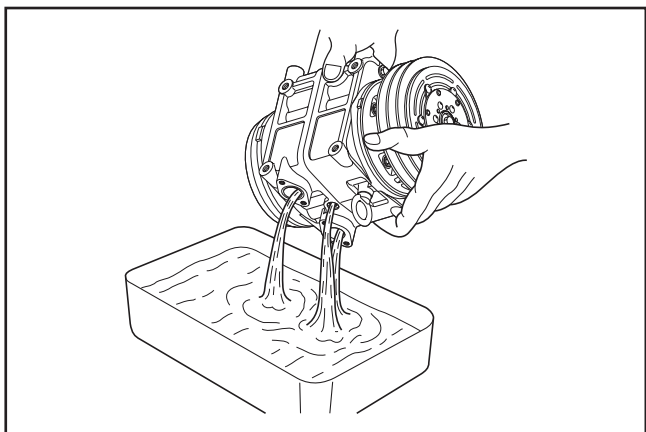

Oil check

The compressor oil must be checked as follows when being charged into a used system.

1. Perform the oil return operation (p.18).
2. Remove the compressor from the vehicle.
3. Remove the oil filler plug and drain the oil through the oil filler plug and the high and low pressure connectors.
4. Check the oil for contamination.
5. Fill the compressor with the specified amount of oil (p.20)

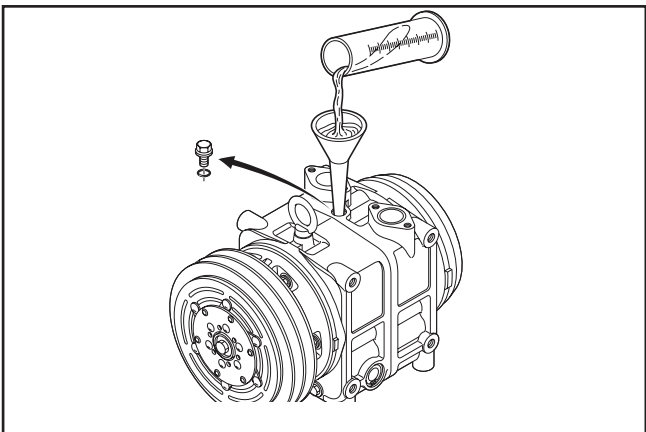

3- Handling instructions

unit: cm³ & cc

		Current Compressor is kept	Compressor is replaced
Factory oil charge	Amount recovered	Charging amount	Amount to remove from new compressor
1500	1000 or more	Same as recovered	1500 - (amount recovered)
	Under 1000	1000	500

unit: cu in

		Current Compressor is kept	Compressor is replaced
Factory oil charge	Amount recovered	Charging amount	Amount to remove from new compressor
91.5	61 or more	Same as recovered	61 - (amount recovered)
	Under 61	61	30.5

CAUTION!

The specified oil quantity differs, depending on the type of air conditioner system. A label describing the specified quantity is attached to the compressor. Additionally, all of the oil cannot be removed when draining the compressor as some remains as an oil film on the inside of the compressor and the system components. Therefore, refer to the table at left when recharging the compressor with oil. Excess oil adversely affects the cooling capacity and the compressor.

6. Install the oil filler plug and tighten it to the specified torque.

Specified torque: 15 - 18 N·m
{1.5 - 1.8 kgf·m, 11 - 13 lbf·ft}

CAUTION!

The oil filler plug O-ring must be replaced with a new one.

Replacement of components

When replacing the component parts of the system, supply the following amount of oil to the compressor.

Component mounted	Amount of oil
Evaporator	300 cm ³ (18.3 cu in)
Condenser	200 cm ³ (12.2 cu in)
Receiver drier	100 cm ³ (6.1 cu in)
Pipe or hose	100 cm ³ (6.1 cu in)

After installing these component parts, check the compressor oil. Refer to page 18.

3- Handling instructions

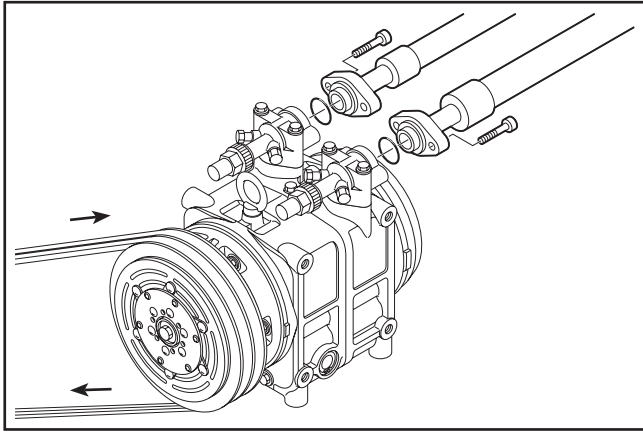

Running-in operation

Whenever moving parts have been replaced, it is necessary to run-in both the compressor and the magnetic clutch.

Compressor running-in

Reassembled compressors must be run-in after the leak test (see next page).

1. Check that the compressor contains the specific amount of oil.
2. Install the compressor on the test bench.
3. Install the high pressure connector and the low pressure connector to the ports and tighten the bolts to the specified torque.

**Specified torque: 25 - 32 N·m
{2.5 - 3.3 kgf·m, 18 - 24 lbf·ft}**

4. Connect the two connector ports using a flexible hose.
5. Run the compressor at 1,000 rpm for at least 30 minutes.
6. Replace the oil.
7. Repeat the leak test.

CAUTION!

While the compressor is being run-in in step 5 above, check the outside temperature of the front head. If the temperature exceeds 80°C (176°F), stop the running-in operation. Resume the operation when the head has cooled.

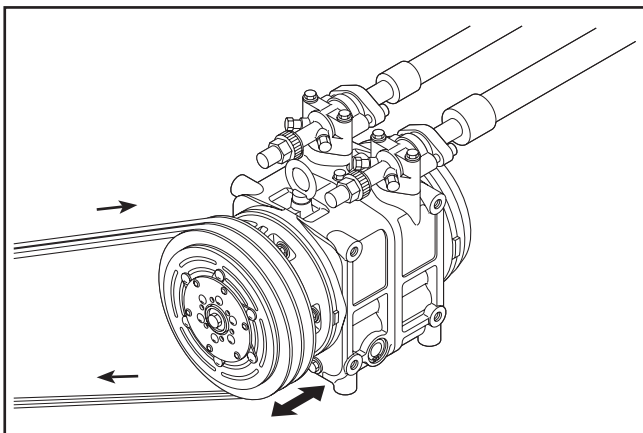

Magnetic clutch running-in

1. Install the clutch on the compressor.
2. Install the compressor on the test bench, and operate the compressor by running the system.
3. Maintain the compressor speed at 700 rpm. Operate the A/C switch through the ON/OFF cycle at least 50 times ("ON" for 10 seconds and "OFF" for 10 seconds).

3- Handling instructions

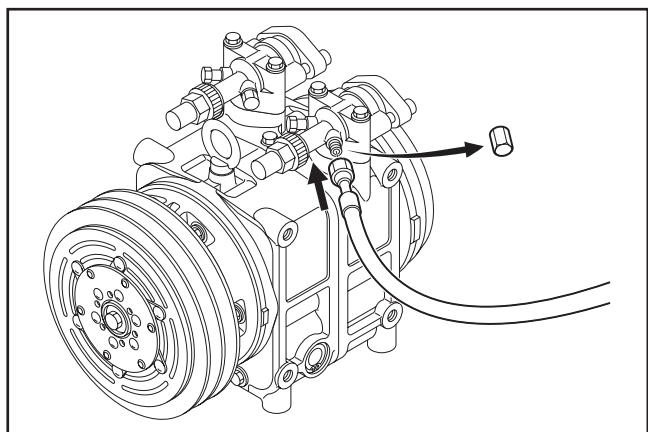

Leak test

The compressor must be checked for refrigerant leaks after it is repaired. The procedure is as follows.

1. Fit the connectors to the suction and discharge connections, and tighten it to the specified torque.

**Specified torque: 25 - 32 N·m
{2.5 - 3.3 kgf·m, 18 - 24 lbf·ft}**

2. Fill the compressor with refrigerant through the suction side, raising the refrigerant pressure to at least 0.39 MPaG {5 kgf/cm², 56.3 psig}.
3. Check the compressor for leaks using a leak detector.

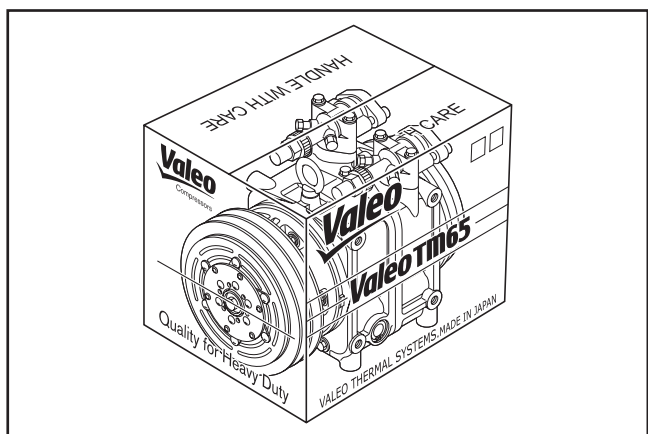
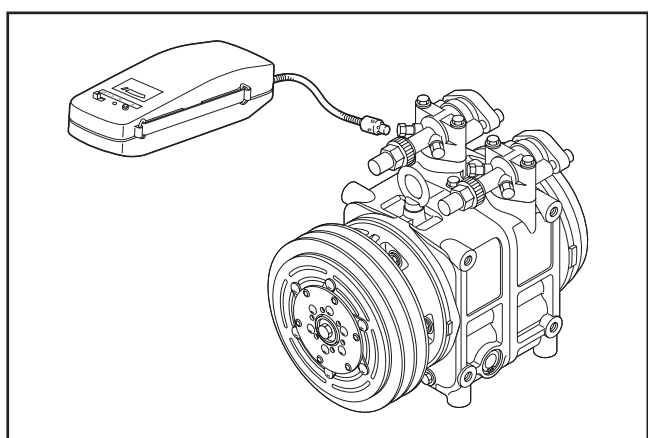

Storing a repaired compressor

If it is necessary to store a repaired compressor for some time before installation, evacuate the compressor and fill it with dry nitrogen gas through the suction fitting to raise the pressure to 30 ~ 100 kPa {0.3 - 1.0 kgf/cm², 4.4 - 14.5 psi}.

4- Troubleshooting

Compressor troubleshooting

When a trouble occurs during the compressor operation, it is often difficult to pinpoint exactly the cause of the malfunction.

As long as the compressor maintenance is done correctly, there should not be any problem throughout the whole vehicle life, but in case it ever happens, we hope this troubleshooting can help you solve the issue efficiently.

Below are listed most of the troubles you may encounter while the A/C is ON.

Please refer to the compressor troubleshooting tree to localize the malfunction symptom, then look at the table (p.24 - 25) for the appropriate measure.

Most of the malfunction symptoms can be classified in the following categories:

1. Insufficient cooling capacity
2. Abnormal noise
3. Smoke

In case of insufficient cooling capacity, we recommend that you prepare a gauge manifold to measure the pressure of both discharge and suction sides (for a detailed diagnosis by gauge pressure, see p.26 - 27).

Compressor troubleshooting tree

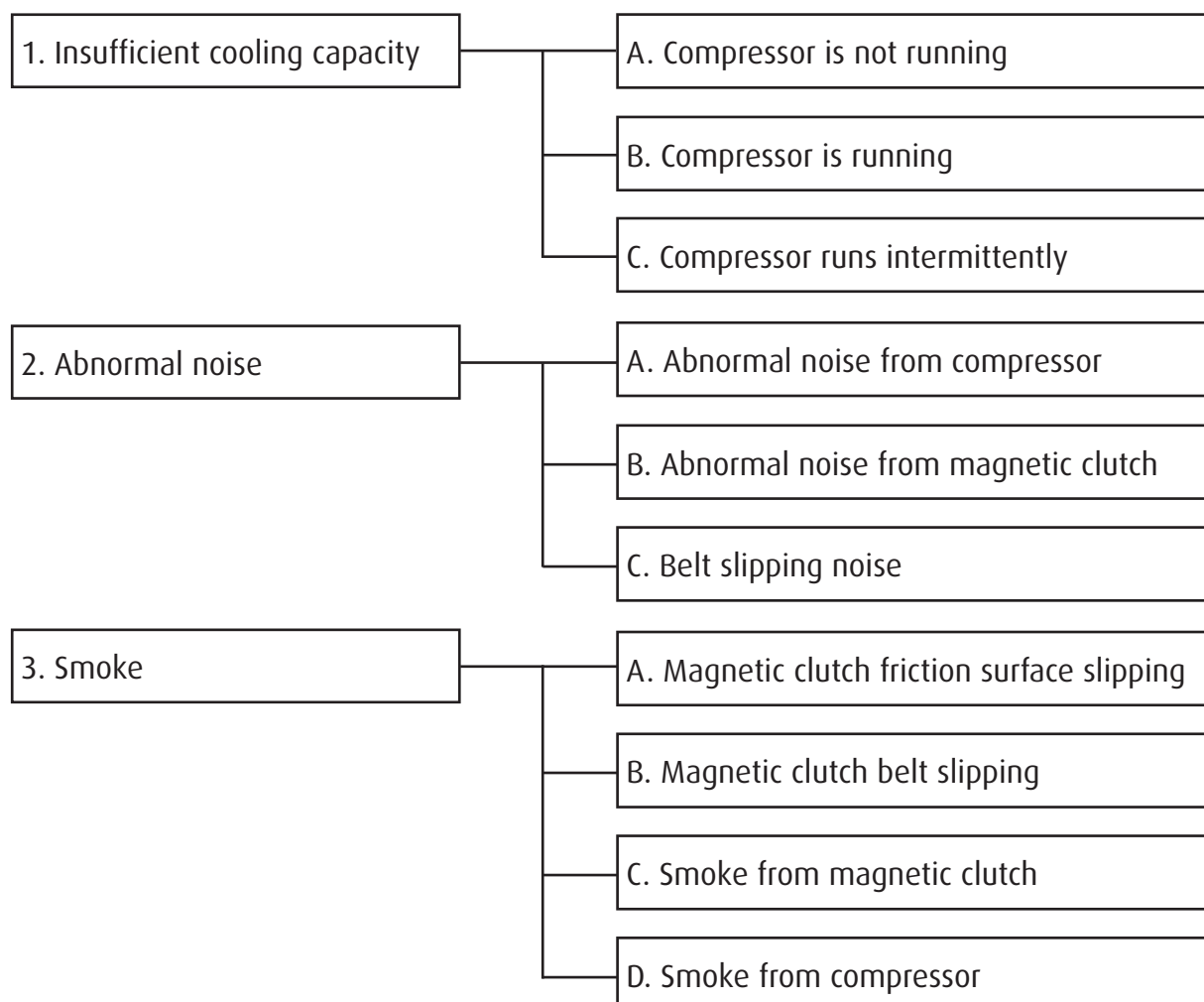

4- Troubleshooting

1. Insufficient cooling capacity

	Trouble	Symptom	Possible cause	Measure
A	Compressor is not running (No cool blow coming out)	Magnetic clutch slips when turning on the A/C switch	Compressor internal part damage	Replace the compressor
		Low pressure cut switch operate (see p.26 - 27)	Refrigerant shortage	Fix the refrigerant leakage then fill with refrigerant until having the right amount
		The magnetic clutch slips or does not engage when the compressor runs	Lead wire short circuit or wiring connector not seated properly	Replace the lead wire if it is defective
			Magnetic clutch damage	Repair or replace the magnetic clutch
			Magnetic clutch air gap too wide	Adjust air gap or replace magnetic clutch
			Low magnetic clutch voltage	Charge battery
		The magnetic clutch engages but the armature does not rotate	Belt slipping	Replace the compressor if it is locked
		Belt run off the pulley	Compressor internal part damage or magnetic clutch damage	Replace the compressor or the magnetic clutch
Center bolt is loose / Center bolt is missing	Bolt drop off/ Armature drop off	Replace magnetic clutch		
B	Compressor is running (No cool blow coming out)	Compressor is running normally	Poor compression	Replace the compressor
		No difference of temperature between discharge side and suction side (see p.26 - 27)	Refrigerant shortage	Fix the refrigerant leakage then fill with refrigerant until having the right amount
		The magnetic clutch slips or does not engage when the compressor is running	Magnetic clutch friction surface slipping	Charge the battery or replace the magnetic clutch
			Loose connection of the magnetic clutch electrical circuit	Replace the magnetic clutch after making sure it is defective
		Belt slipping	Magnetic clutch belt slipping	Belt tension readjustment
		The magnetic clutch does not engage	Defective sensor	Replace the sensor after making sure it is defective
C	Compressor runs intermittently (Cool blow comes out only from time to time)	Both discharge and suction pressures are high	Excess of refrigerant	Reduce the refrigerant charge until reaching the right amount
			Condenser fan failure	Replace the condenser after making sure it is defective
		The magnetic clutch slips or does not engage when the compressor is running	Loose connection of the magnetic clutch electrical circuit	Replace the magnetic clutch after making sure it is defective
		The magnetic clutch does not engage	Defective sensor	Replace the sensor after making sure it is defective

4- Troubleshooting

2. Abnormal noise

	Trouble	Symptom	Possible cause	Measure
A	Abnormal noise from the compressor	Abnormal vibration after turning on the A/C switch	Compressor installation bolt is loose	Increase tightening torque of the loose bolts
			Wide gap at the attaching portion between the compressor and the bracket	Improve the compressor attaching portion
		Abnormal noise from the compressor body	Compressor body internal component damage	Replace the compressor
B	Abnormal noise from the magnetic clutch	The magnetic clutch has a backlash and slips	Magnetic clutch damage	Replace the magnetic clutch
		Strange noise when the magnetic clutch engages	Air gap too wide	Adjust air gap or replace magnetic clutch
		Armature slips / does not engage when the compressor is running	Magnetic clutch friction surface slipping	Charge battery or replace magnetic clutch
C	Abnormal noise from the magnetic clutch	Armature does not rotate when magnetic clutch engages	Belt slipping	Replace the compressor if locked. Readjust the belt tension if the belt is loose

3. Smoke

	Trouble	Symptom	Possible cause	Measure
A	Magnetic clutch friction surface slipping	The magnetic clutch slips / does not engage when the compressor is running	Magnetic clutch air gap too wide	Adjust air gap or replace magnetic clutch
			Low magnetic clutch voltage	Charge battery
			Magnetic clutch friction surface is greasy	Clean friction surface or replace magnetic clutch
B	Magnetic clutch belt slipping	The magnetic clutch slips / does not engage when the compressor is running	Belt alignment is not correct	Adjust the compressor installation position
			Magnetic clutch belt is greasy	Clean or replace the belt
			Magnetic clutch belt tension is loose	Adjust belt tension
C	Smoke from the magnetic clutch	The magnetic clutch does not engage	Coil open or shorted	Replace the magnetic clutch
D	Smoke from the compressor	Refrigerant / oil is billowing out	Refrigerant leaking, uncoupled piping or piping burst	Fix the refrigerant leakage then fill with refrigerant until having the right amount

4- Troubleshooting

A/C cycle diagnosis by gauge pressure

Following is a diagnosis procedure to connect gauge manifold to A/C cycle, measure suction and discharge pressures and analyze the defects of the cycle.

Operation conditions of the A/C cycle for pressure measuring:

1. Ambient temperature: 30 - 35 °C
2. Engine speed: 1.500 rpm
3. A/C switch: ON
4. Blower speed: high
5. Temperature control: full cold

Gauge pressure indication	Cause	Confirmation method	Action to take
Pressure is normal	A/C cycle operates normally. If there is any defect (poor cooling performance), there shall be another cause <div style="border: 1px solid black; padding: 5px; margin: 10px 0;"> Discharge pressure: around 0.9 - 1.6 MPaG (10 - 17 kgf/cm²) Suction pressure: around 0.03 - 0.10 MPaG (1.3 - 2.0 kgf/cm²) </div>		
Both discharge and suction pressures are low <div style="border: 1px solid black; padding: 5px; margin: 10px 0;"> Suction pressure becomes vacuum </div>	Refrigerant shortage	Connect gauge manifold to cycle	Recover refrigerant, then refill with the right amount of refrigerant
	Receiver dryer is clogged	Temperature difference between inlet and outlet pipes happens. Dryer is covered with frost	Replace parts
	Expansion valve is clogged	Expansion valve was covered with frost	Clean or replace part
	Enclosure leakage from TXV temperature sensing tube. (TXV operates to close the valve opening)	Outlet side of TXV is not cooling. (Low side of gauge indicates vacuum)	Replace part
	Temperature sensing device at outlet air is defective	Evaporator becomes frozen up	Adjust or replace the part
	Refrigerant piping is clogged or crashed	If any part between the dryer and the compressor is clogged or crashed, the low side pressure becomes vacuum	Adjust or replace the part

4- Troubleshooting

Gauge pressure indication	Cause	Confirmation method	Action to take
Both discharge and suction pressures are high	Excess of refrigerant	Connect gauge manifold to cycle	Recover refrigerant, then refill with the right amount of refrigerant
	Condenser cooling malfunction	Condenser becomes muddy and fins are clogged and collapsed. Defect of cooling fan rotation. Malfunction of fan motor for condenser.	Clean up, hand repair of fin and replacement
	Misaligned TXV or thermal sensing tube of TXV is not fit on regularly. (Excess opening of TXV)	Defective refrigerant flow control, the thermal sensing tube is not closely in contact with the evaporator pipe	Adjustment or replacement
	Air mixed in refrigeration cycle	Just after compressor stops, discharge pressure will come down immediately to 0.19 - 0.29 MPaG (3 - 4 kgf/cm ²)	Evacuate air from cycle, the charge with the adequate amount of refrigerant.
Discharge pressure is high and suction pressure is low	Refrigerant cycle is clogged between compressor and condenser	Appreciable temperature difference at the clogged location	Clean up inside the cycle or replace the part
Discharge pressure is low and suction pressure is high	Defect of the compressor valve or gasket	Discharge and suction pressures balance immediately after the compressor stops. (Defective compression of compressor)	Replace the compressor

5- Tightening torques

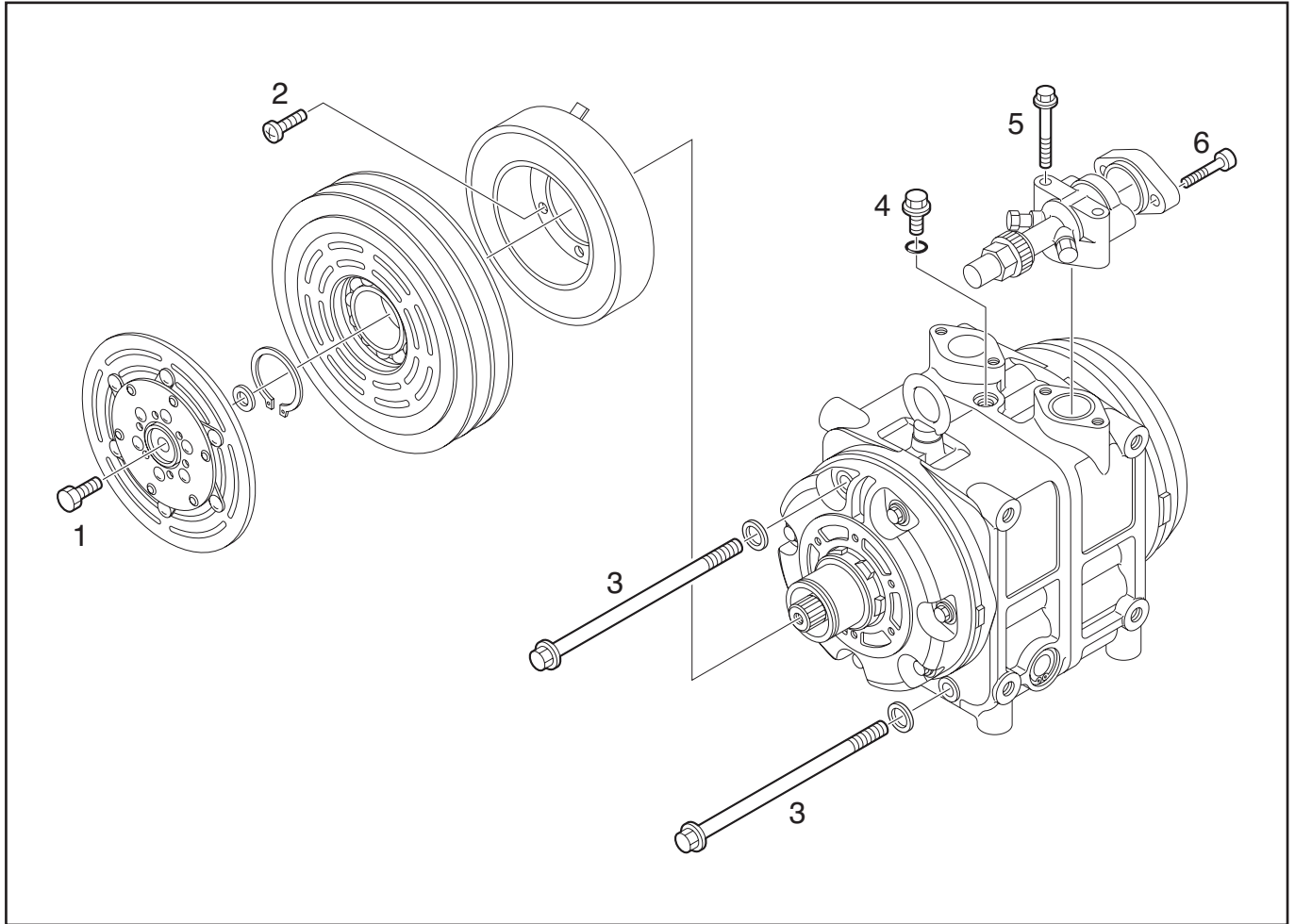

Unit: N·m {kgf·m, lbf·ft}

Part	Thread size	Tightening torque
1. Center bolt	M10 x 1.25	25 - 30 {2.5 - 3.1, 18 - 22}
2. Field coil screw	M6 x 1.0	4.2 - 7.2 {0.4 - 0.7, 3.1 - 5.3}
3. Bolt	M10 x 1.5	25 - 32 {2.5 - 3.3, 18 - 24}
4. Oil filler plug	M10 x 1.5	15 - 18 {1.5 - 1.8, 11 - 13}
5. Connector bolt	M10 x 1.5	25 - 32 {2.5 - 3.3, 18 - 24}

6- Service procedures - Magnetic clutch

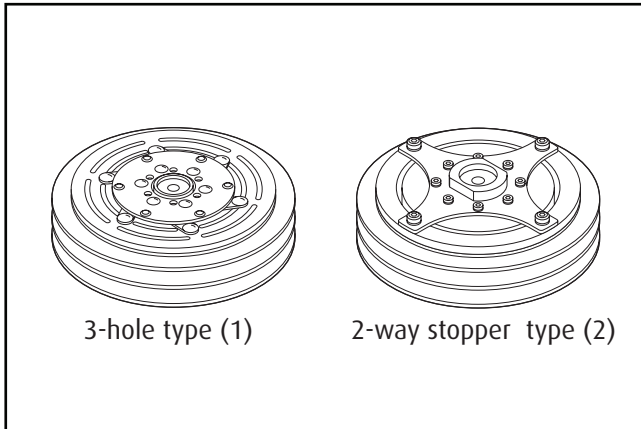

Magnetic clutch

Removal

1. Check your armature type (see at left):
 - 3-hole type (1)
 - 2-way stopper type (2)

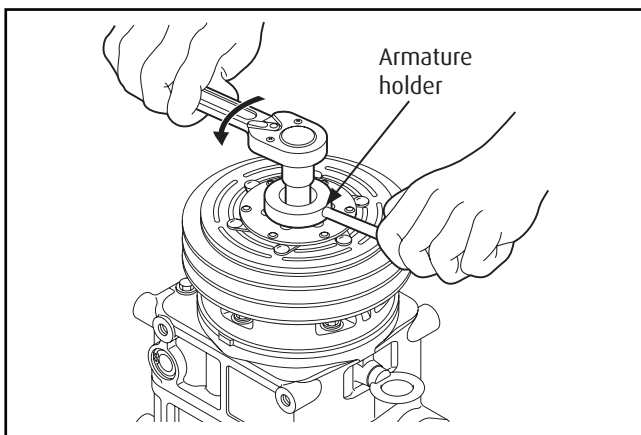

2. Remove the armature.

CAUTION!

The armature removal process differs according to the armature type

- If it is a 3-hole type armature (1)
 - a. Remove the center bolt using an armature holder to prevent armature assembly rotation.

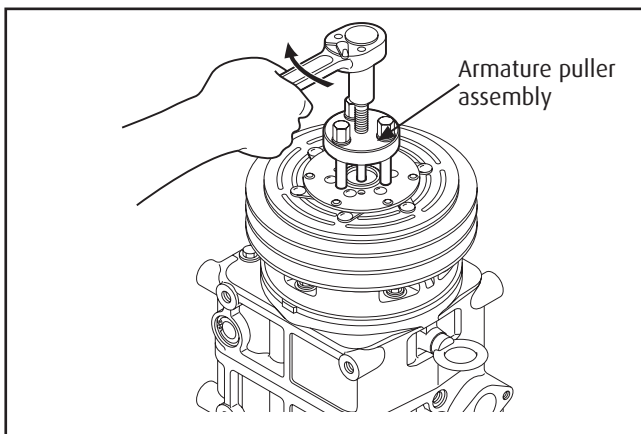

- b. Remove the armature assembly using an armature puller assembly. Remove the shims from the compressor driveshaft or armature assembly.

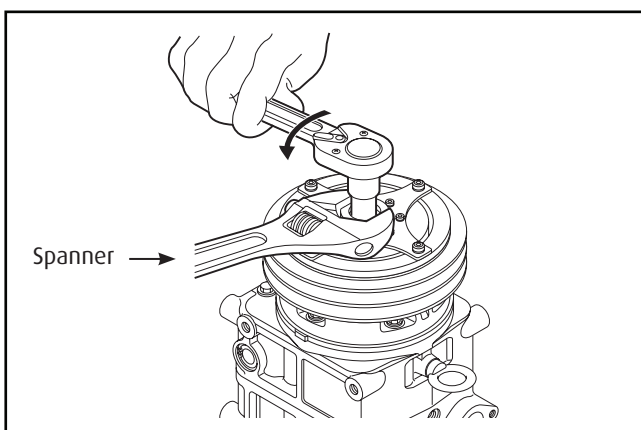

- If it is a 2-way stopper type armature (2)
 - a. Remove the center bolt using a spanner to prevent armature assembly rotation.

6- Service procedures - Magnetic clutch

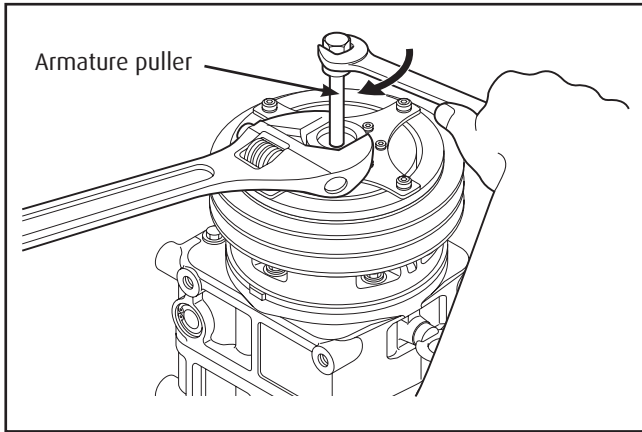

- b. Remove the armature assembly using an armature puller. Remove the shims from the compressor driveshaft or armature assembly.

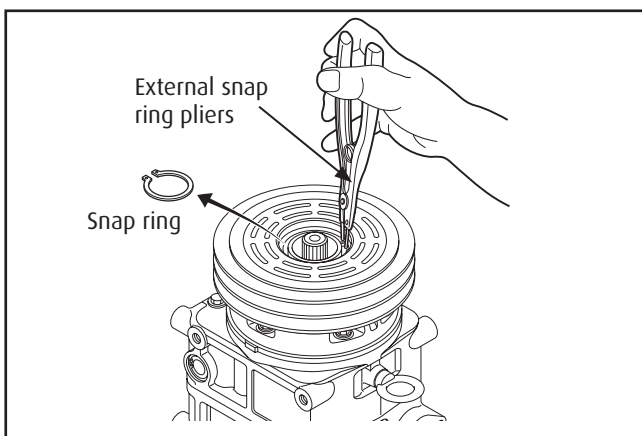

3. Remove the snap ring (Z0010244) using external snap ring pliers.

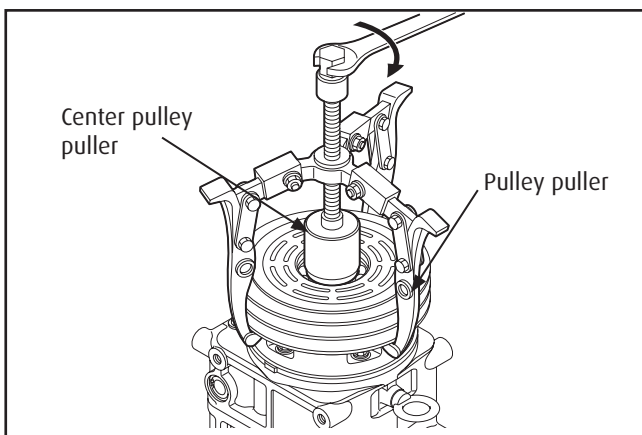

4. Position the center pulley puller at the end of the driveshaft.
5. Attach a suitable pulley puller to the pulley. Hook the puller claws to the edge of the pulley as shown.
6. Tighten the center pulley puller bolt to remove the pulley.

7. Remove the six field coil/compressor screws. Then remove the field coil.

WARNING!

Removing the pulley will systematically damage the pulley bearing.

CAUTION!

Do not clip the puller claws into the pulley groove to prevent pulley groove damage.

CAUTION!

Do not hold the field coil by the harness.

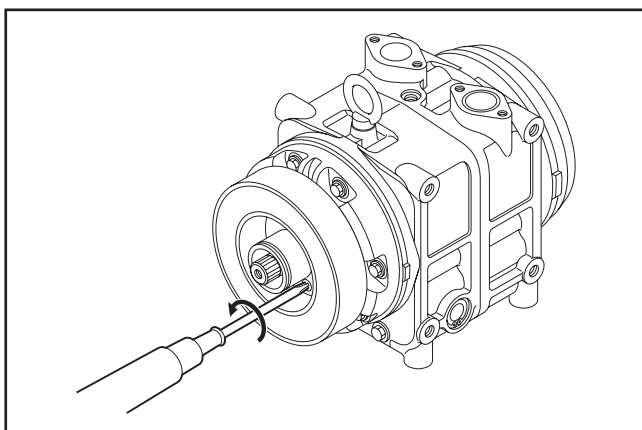

6- Service procedures - Magnetic clutch

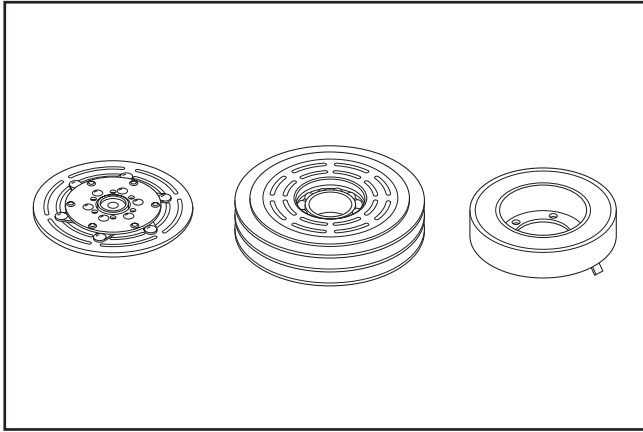

Magnetic clutch

Inspection

1. If the contact surface has been damaged by excessive heat, the armature and pulley must be replaced.
2. Check the appearance of the pulley assembly. If the contact surface of the pulley is excessively grooved due to slippage, both the pulley and armature must be replaced. The contact surface of the pulley assembly must be cleaned with a suitable solvent before reinstallation.
3. Check the field coil for a loose connector or cracked insulation.

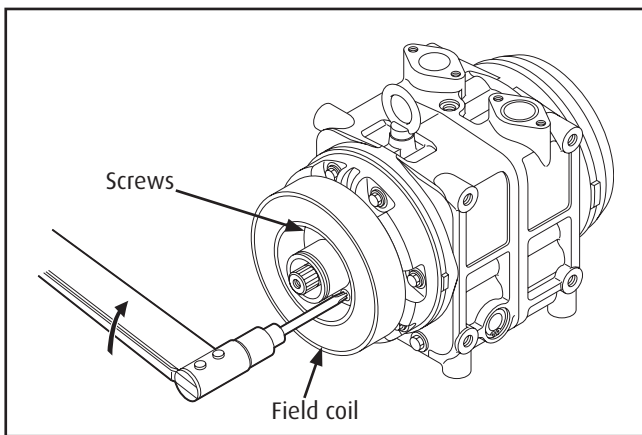

Installation

1. Install the field coil on the compressor (with the harness on top) and tighten the mounting screws to the specified torque.
Specified torque: 4.2 - 7.2 N·m
{0.4 - 0.7 kgf·m, 3.1 - 5.3 lbf·ft}
2. Carefully place the wire harness/strain relief.

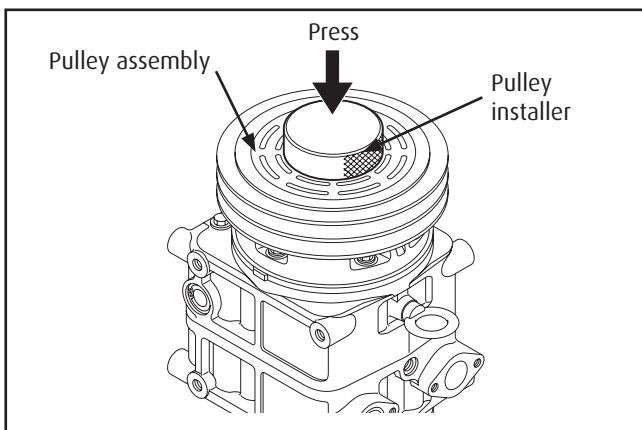

- If you are using a press
3. Install the pulley assembly using the pulley installer and the press.

CAUTION!

Use only a press to install the pulley assembly. Do not use a hammer. The use of a hammer may result in damage or deformation.

6- Service procedures - Magnetic clutch

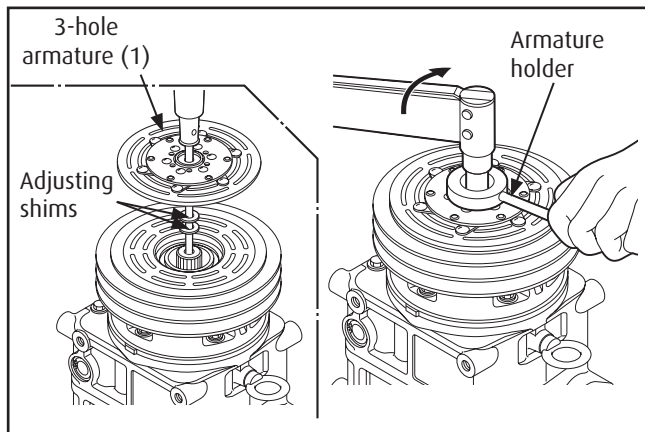

4. Install the armature assembly on the driveshaft together with the original shim(s) and press it down.
5. Install the armature bolt and tighten it to the specified torque using an armature holder (for 3-hole armature) or a spanner (for 2-way stopper armature) to prevent armature assembly rotation.

Specified torque: 25 - 30 N·m
{2.5 - 3.1 kgf·m, 18 - 22 lbf·ft}

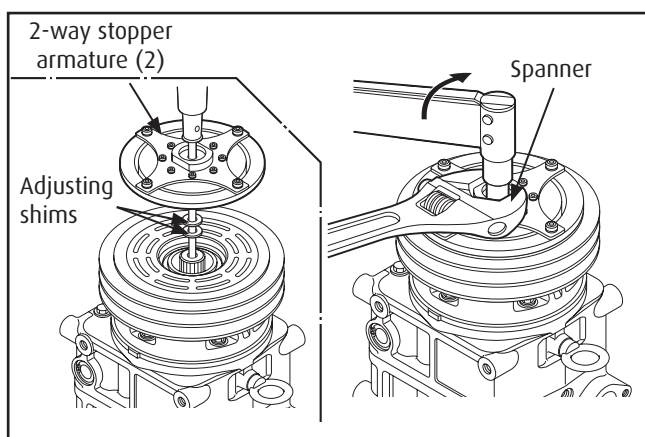

6. Check that the clutch clearance is as specified. If necessary adjust the clearance using shim(s). Adjusting shims are available in the following thicknesses:

Shim Part No.	Thickness
Z0010245	0.2 mm {0.008 in}
Z0010246	0.3 mm {0.012 in}

Specified clearance: 0.3 - 0.7 mm
{0.012 - 0.028 in}

8. Run in the clutch as described on page 21.

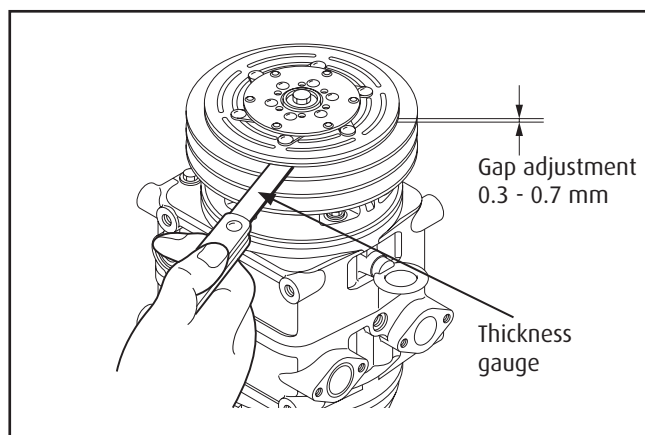

6- Service procedures - Magnetic clutch

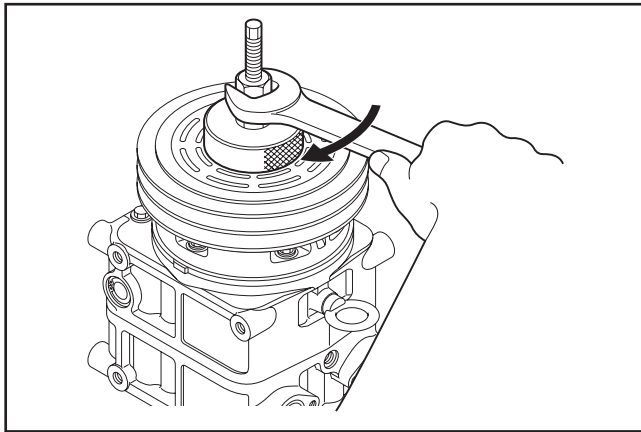

- If you are not using a press
3. Install the pulley using a pulley installer assembly and a spanner.

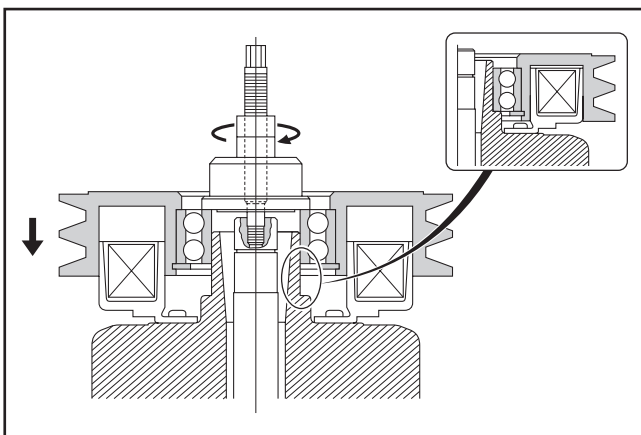

CAUTION!

If the bolt of the pulley installer assembly is not screwed into the driveshaft, it may result in damage.

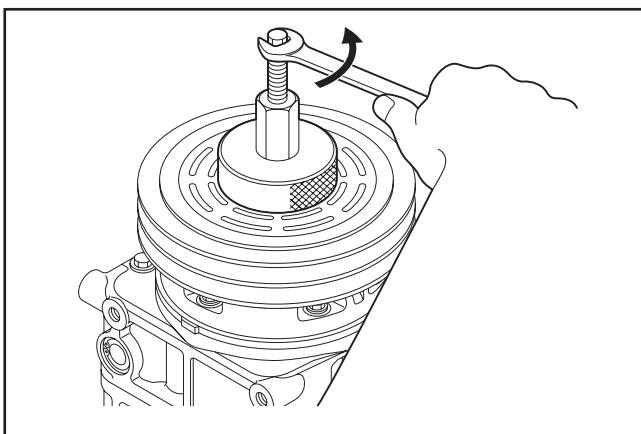

4. Once the pulley is fixed, loose the collar and remove the pulley installer assembly.

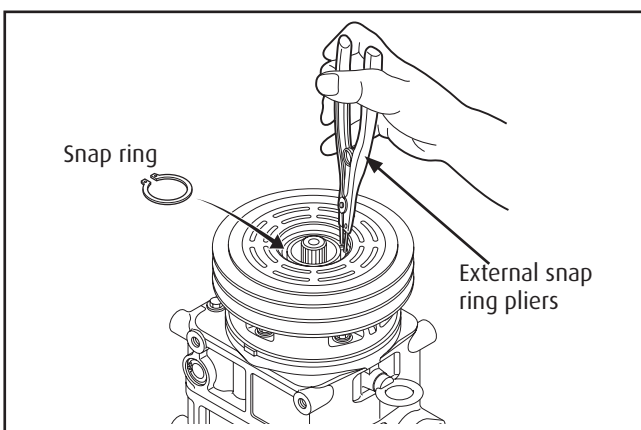

5. Install the snap ring (beveled edge up) using external snap ring pliers.

6- Service procedures - Magnetic clutch

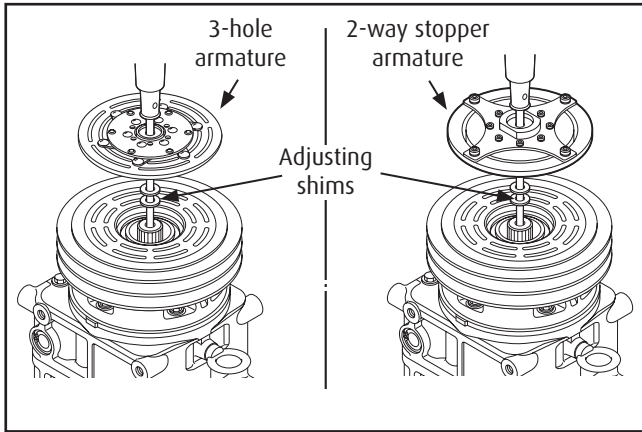

6. Install the armature assembly on the driveshaft together with the original shim(s).

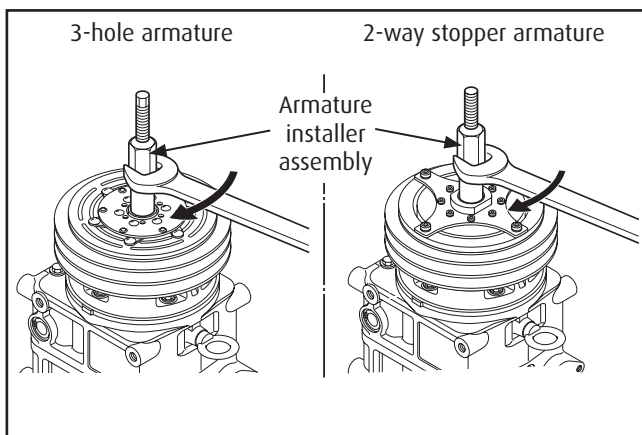

7. Install the armature assembly using an armature installer assembly.

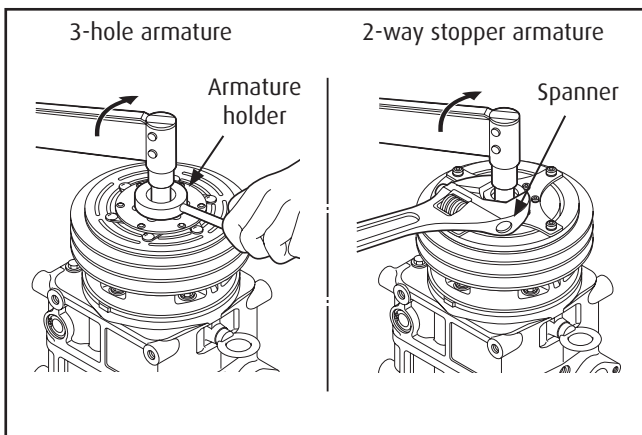

8. Install the armature bolt and tighten to the specified torque using an armature holder or a spanner to prevent armature assembly rotation.

Specified torque: 25 - 30 N·m
{2.5 - 3.1 kgf·m, 18 - 22 lbf·ft}

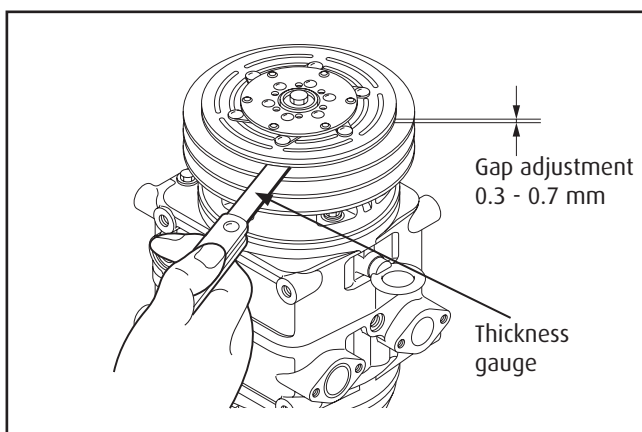

9. Check that the clutch clearance is as specified. If necessary adjust the clearance using shim(s). Adjusting shims are available in the following thicknesses:

Shim Part No.	Thickness
Z0010245	0.2 mm {0.008 in}
Z0010246	0.3 mm {0.012 in}

Specified clearance: 0.3 - 0.7 mm
{0.012 - 0.028 in}

8. Run in the clutch as described on page 21.

7- Service procedures - Shaft seal assembly

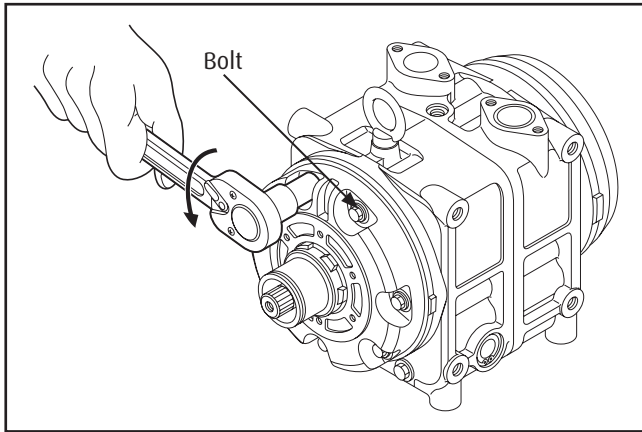

Removal

1. Remove the magnetic clutch assembly as described on page 29.
2. Remove the bolts securing the connectors, and then remove the connectors and strainer from the cylinder shaft assembly.
3. Remove the oil filler plug and then drain the oil.
4. Remove the seven bolts securing the head using an hexagon (14 mm) wrench.

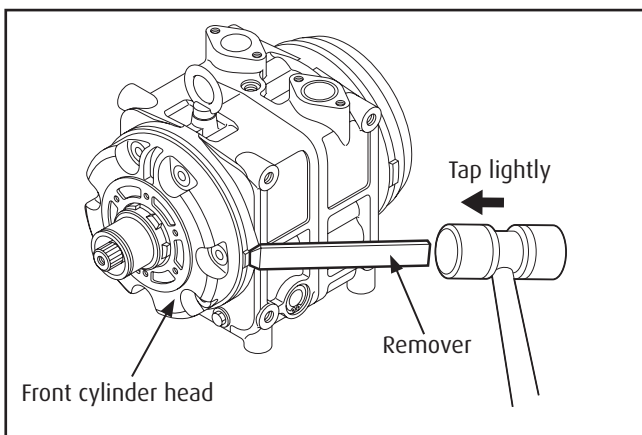

5. Alternately tap the two projections on the front head using a remover and a mallet to remove the front cylinder head.

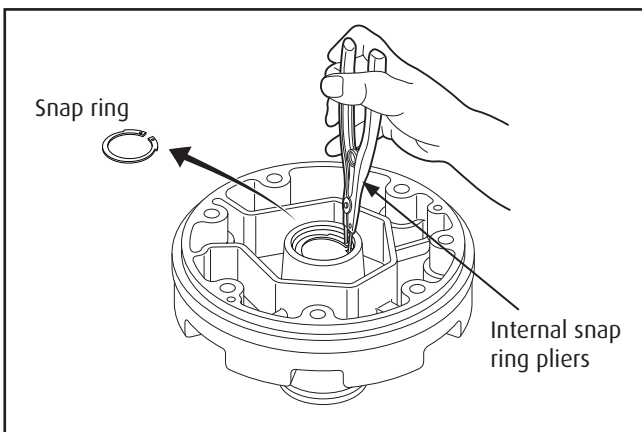

6. Remove the snap ring using the internal snap ring pliers.

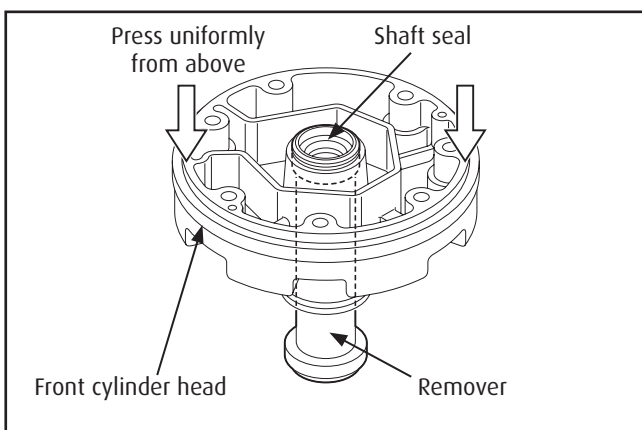

7. Remove the shaft seal assembly using a remover.

7- Service procedures - Shaft seal assembly

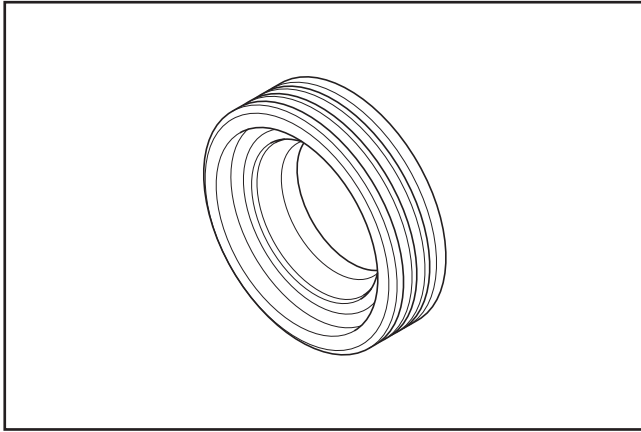

Inspection

The shaft seal must not be reused.

Always use a new shaft seal when reassembling the compressor. Ensure that the seal seat is free from lint and dirt that could damage the shaft seal lip.

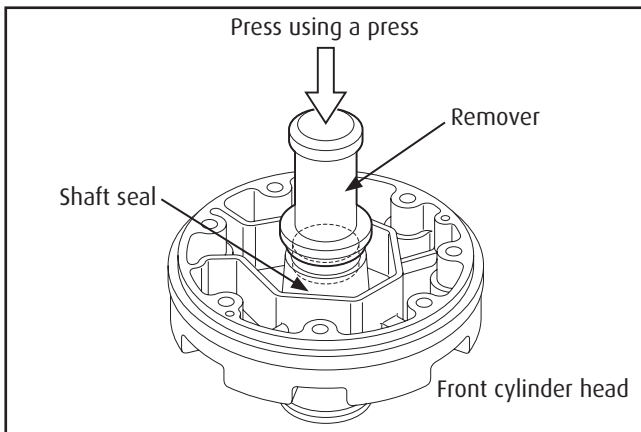

Installation

1. Clean the portion of the front cylinder head where the shaft seal is to be assembled.
2. Assemble the shaft seal on the remover.
3. Coat the shaft seal well with compressor oil and install the shaft seal in the front cylinder head with the shaft seal remover.
4. Install the snap ring using the internal snap ring pliers.

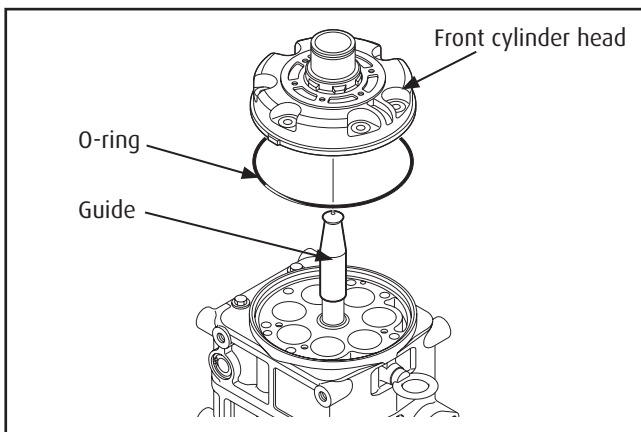

5. Position the guide on the shaft
6. Coat the new O-ring with clean compressor oil and install it in the front cylinder head
7. Install the front cylinder head

CAUTION!

Align the pins and tap the head lightly and evenly with a plastic hammer.

8. Remove the guide
9. Install the seven bolts from the front cylinder head side and tighten them to the specified torque:

**Specified torque: 25 - 32 N·m
{2.5 - 3.3 kgf·m, 18 - 24 lbf·ft}**

Tighten each bolt gradually (in three or more stages) to ensure the specified torque.

10. Turn the drive shaft 2, 3 times by hand to ensure that the shaft rotates smoothly.

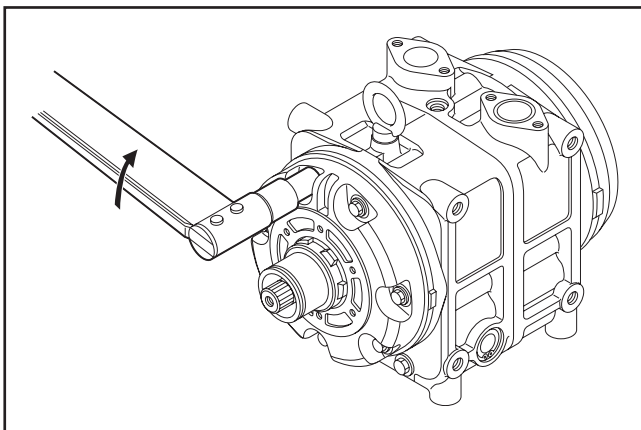

7- Service procedures - Shaft seal assembly

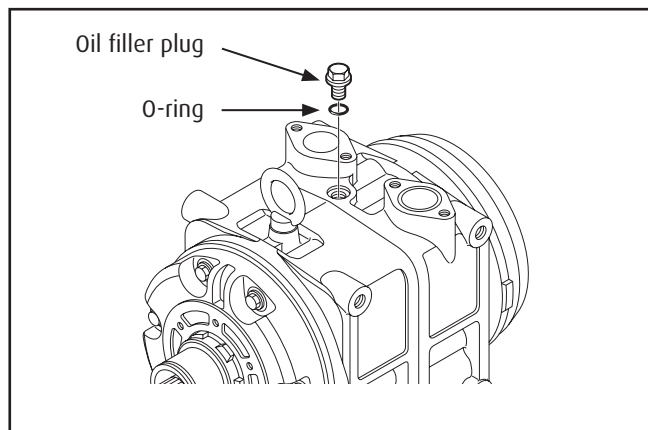

11. Fill the compressor with the specified amount of clean compressor oil through the oil filler.
12. Install the oil filler plug with a new O-ring, and tighten it to the specified torque:
Specified torque: 15 - 18 N·m
{1.5 - 1.8 kgf·m, 11 - 13 lbf·ft}
13. Install the strainer in the suction port.
14. Fit the blanking plates/connectors to the suction and discharge connections, and tighten them to the specified torque:
Specified torque: 25 - 32 N·m
{2.5 - 3.3 kgf·m, 18 - 24 lbf·ft}
15. Install the magnetic clutch as described on page 31.
16. Run in the compressor as described on page 21.
17. Perform the leak test as described on page 22.

8- Service procedures - Cylinder heads

Cylinder heads (Front & Rear)

Disassembly

1. Remove the magnetic clutch assembly as described on page 29.
2. Remove the four bolts securing the connectors, and then remove the connectors and strainer from the cylinder shaft assembly.
3. Remove the oil filler plug and then drain the oil.
4. Remove the seven bolts securing the heads.
5. Alternately tap the two projections on the front head using the remover and mallet to remove the front cylinder head.
6. Remove the front valve plate assembly and then the suction valve (in that order).
7. Remove and discard the O-ring from the front cylinder head.
8. Remove all gasket material from the front cylinder head and the front valve plate.

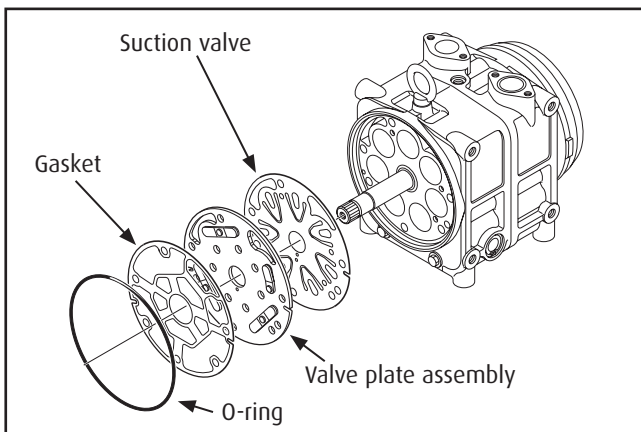
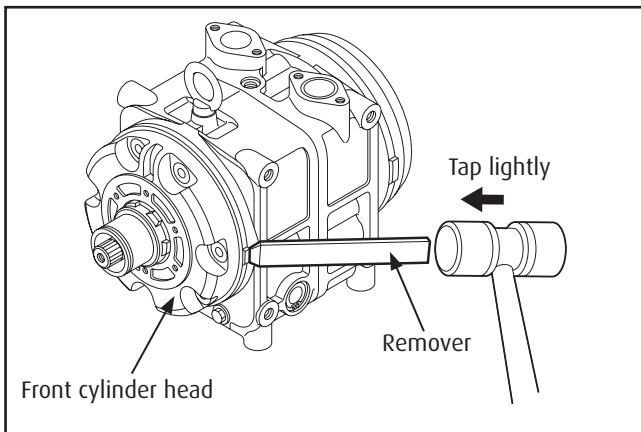
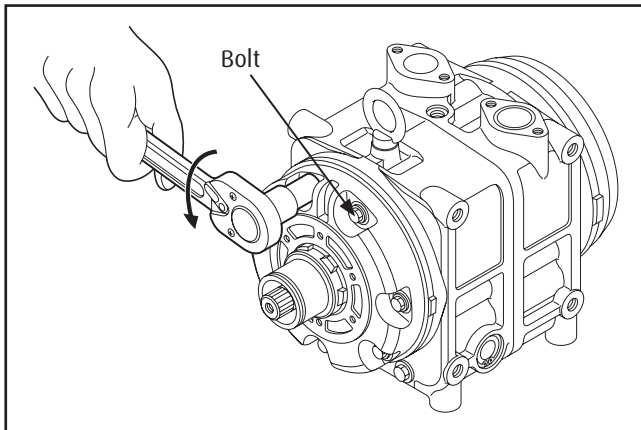

8- Service procedures - Cylinder heads

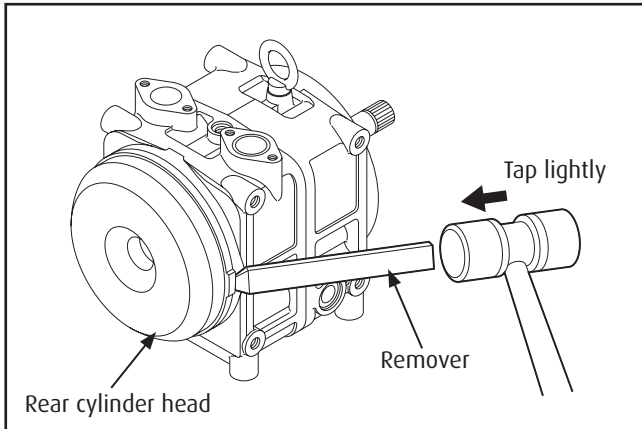

9. Alternately tap the two projections on the rear head using the remover and mallet to remove the rear cylinder head.

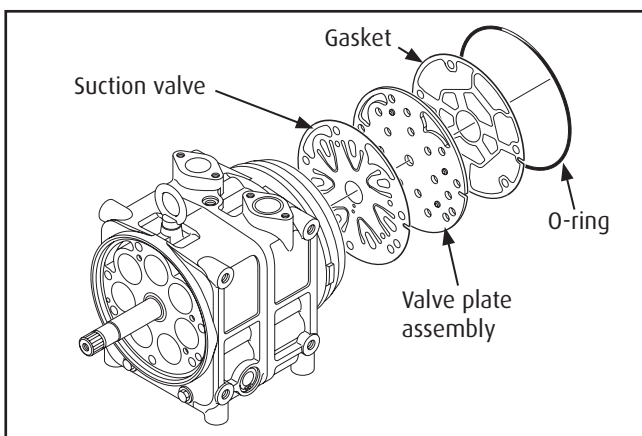

10. Remove the rear valve plate assembly and then the suction valve (in that order).

11. Remove and discard the O-ring from the rear cylinder head.

12. Remove all gasket material from the rear cylinder head and the rear valve plate.

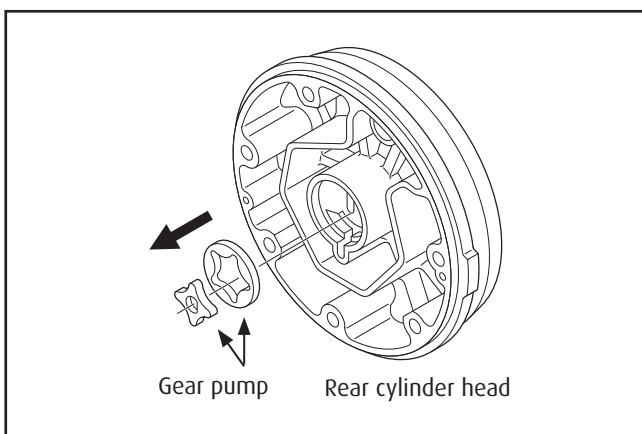

13. Remove the gear pump from the rear cylinder head or the end of the driveshaft.

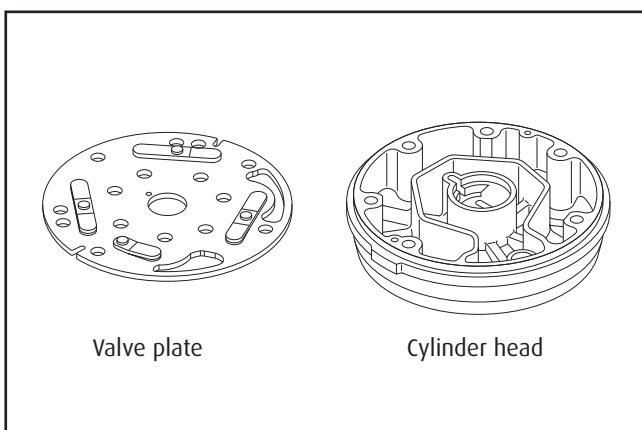

Inspection

Check the front and rear valve plates for scratched, bent or damaged parts.

Inspect both cylinder heads and both valves plates for nicks or burrs on the sealing surfaces.

Clean both cylinder heads and both valve plates or replace them if they are cracked or damaged.

Check that there are no clogged passages in the valve plates.

8- Service procedures - Cylinder heads

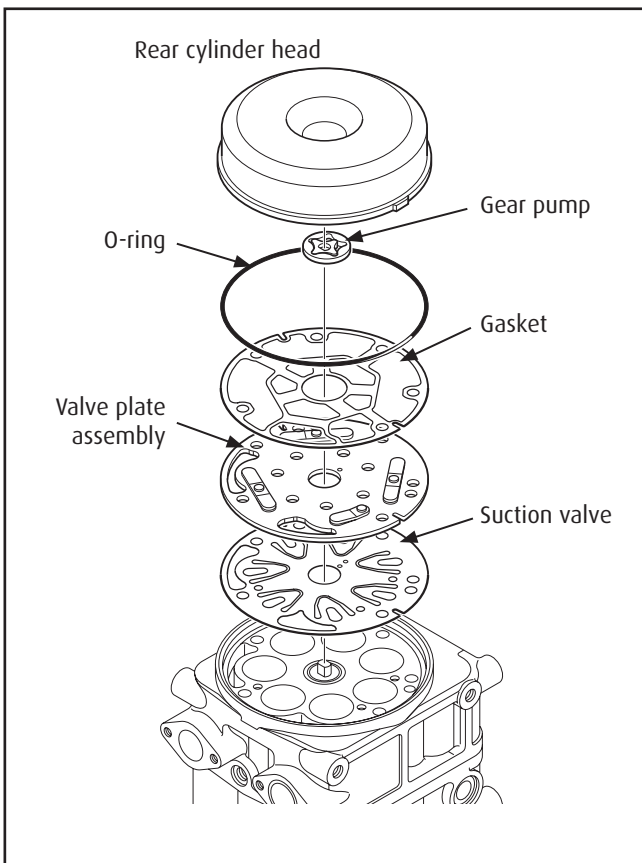
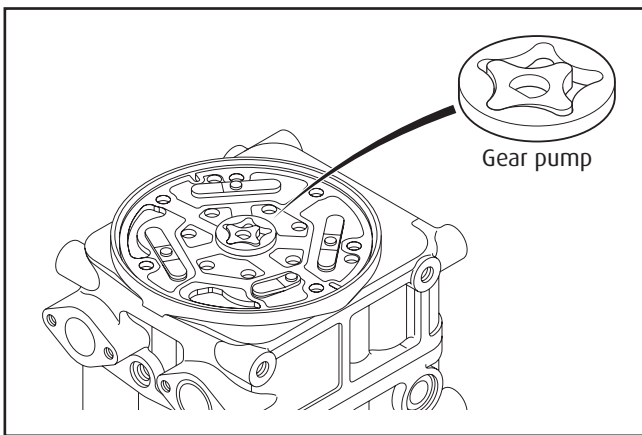
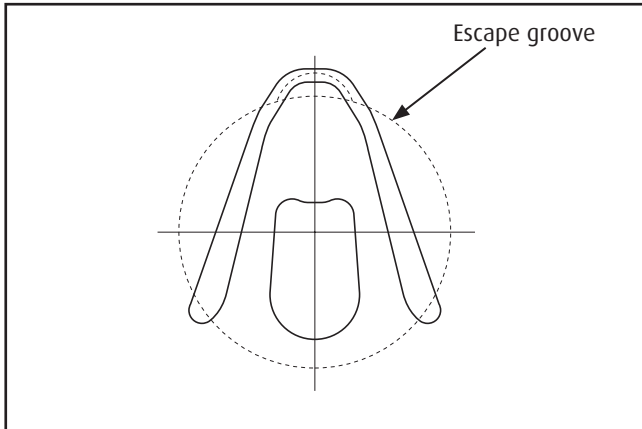

Reassembly

Rear cylinder head

1. Place the cylinder shaft assembly on the bench with the rear side up.
2. Install the rear suction valve so that it matches the pins.

CAUTION!

Ensure each valve matches each cylinder valve escape groove.

3. Install the rear valve plate on the rear suction valve.

CAUTION!

Do not mistake the front and rear valve plates.

4. Coat the new gasket with clean compressor oil and install it on the rear valve plate.
5. Coat the new gear pump with clean compressor oil and install it on the end of the drive shaft.

6. Coat the new O-ring with clean compressor oil and install it on the rear cylinder head.
7. Install the rear cylinder head.

When positioning the head, ensure the gear pump is inserted into the hole in the cylinder head.

8- Service procedures - Cylinder heads

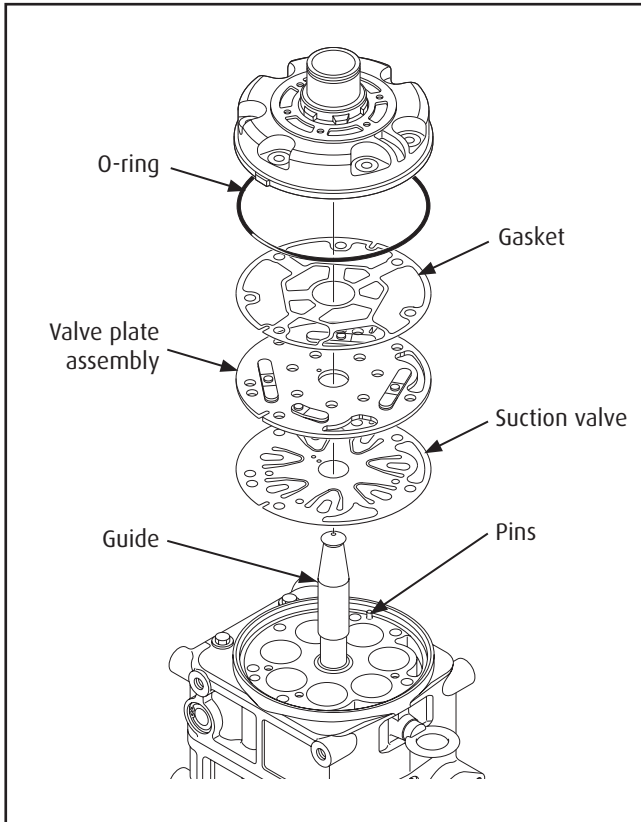

Front Cylinder Head

1. Place the cylinder shaft assembly on the bench with the front side up.
2. Install the front suction valve so that it matches the spring pins.

CAUTION!

Ensure each valve matches each cylinder valve escape groove.

3. Install the front valve plate on the front suction valve.
4. Coat the new gasket with clean compressor oil and install it on the front valve plate.
5. Position the guide on the shaft.
6. Coat the new O-ring with clean compressor oil and install it on the front cylinder head.
7. Install the front cylinder head.

CAUTION!

Align the spring pins and tap the head lightly and evenly with a plastic hammer.

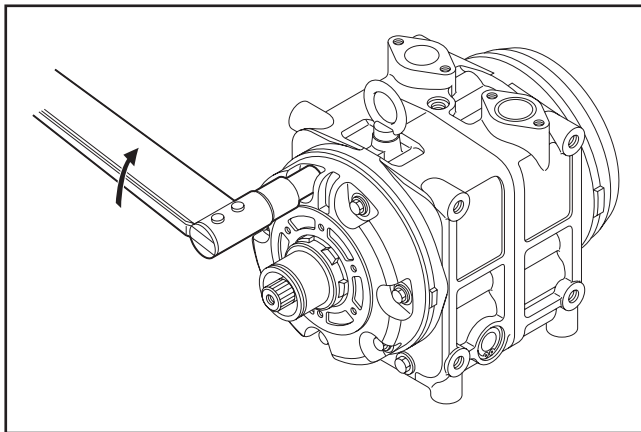

8. Remove the guide.
9. Install the seven bolts from the front cylinder head side and tighten them to the specified torque.

**Specified torque: 25 ~ 32 N·m
{2.5 - 3.3 kgf·m, 18 - 24 lbf·ft}**

Tighten each bolt gradually (in three or more stages) to ensure the specified torque.

10. Turn the drive shaft 2, 3 times by hand to ensure that the shaft rotates smoothly.
11. Fill the compressor with the specified amount of clean compressor oil through the oil filler.
12. Install the oil filler plug with a new O-ring and tighten it to the specified torque.

**Specified torque: 15 - 18 N·m
{1.5 - 1.8 kgf·m, 11 - 13 lbf·ft}**

13. Install the strainer in the suction port.
14. Fit blanking plates/connectors to the suction and discharge connections, and tighten it to the specified torque.

**Specified torque: 25 - 32 N·m
{2.5 - 3.3 kgf·m, 18 - 24 lbf·ft}**

15. Install the magnetic clutch (see p.31).
16. Run in the compressor (see p.21).
17. Perform the leak test (see p.22).

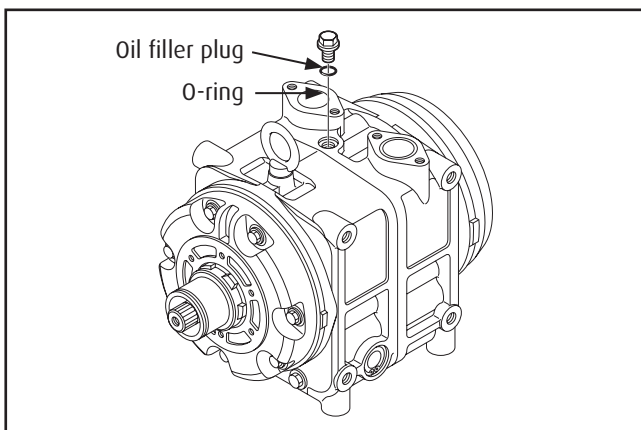







9- Service tools

In addition to standard tools, numerous special tools are necessary to service the Valeo **TM55 & TM65** compressors. The use of these special tools enables prompt and correct compressor service.

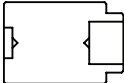
The drawings and the specifications of the service tools listed below are enclosed in the following pages.

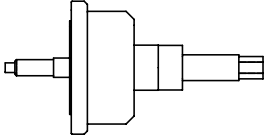
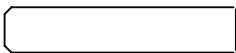
Service tools

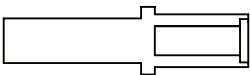
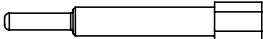
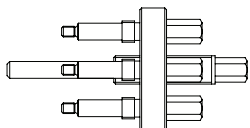
Item	Name	Picture	Ref. page	Application	Drawing page
1	Armature holder		29,32, 34	To fix armature	43
2	Armature installer assembly		34	To install armature	43-44
3	Center pulley puller		30	To remove pulley	45
4	Pulley installer		31	To install pulley	45
5	Pulley installer assembly		33	To install pulley	46-47
6	Cylinder head remover		35, 38, 39	To remove cylinder head and cylinder block	48
7	Guide		36, 41	To install shaft seal	48
8	Shaft seal remover / installer		35, 36	To remove and insert the shaft seal	49
9	Armature puller		30	To remove armature	49
10	Armature puller assembly		29	To remove armature	50-51

9- Service tools

Unless otherwise specified,
the edges to be slight chamfering.
Should remove burrs and fluff.

3rd Angle Proj.	Surface Treatment	Br		
	Heat Treatment & Hardness	- -HOF - HTL HRC40 to 45		
Part Name	Material	① SS41	② SS41	③ S45C
Armature Holder				

① Bolt
② Collar

3rd Angle Proj.	Material		
	Surface Treatment		
Part Name	Heat Treatment & Hardness		
	Material	Assy	
Armature Installer Assy			

9- Service tools

Armature Installer Assy

①

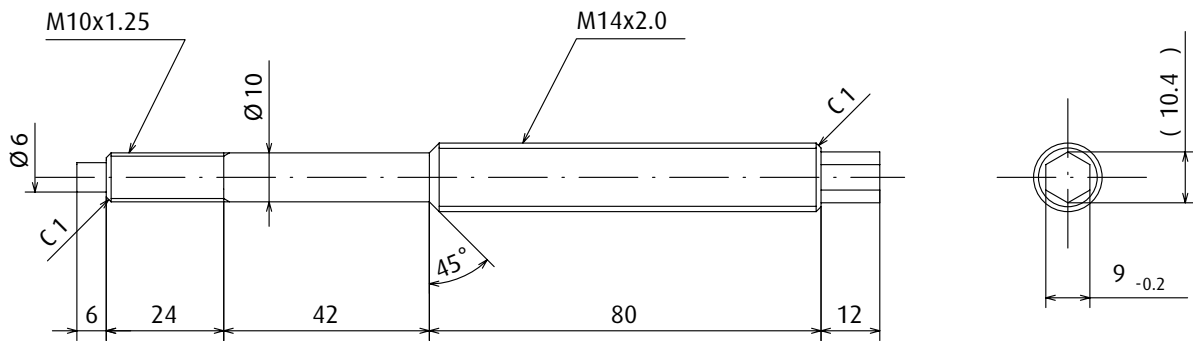

Unless otherwise specified,
the edges to be slight chamfering.
Should remove burrs and fluff.

3rd Angle Proj.

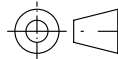

Surface Treatment	Br
Heat Treatment & Hardness	HQ-HQf HRC40 to 45
Material	S45C

Part Name

Bolt

Armature Installer Assy

②

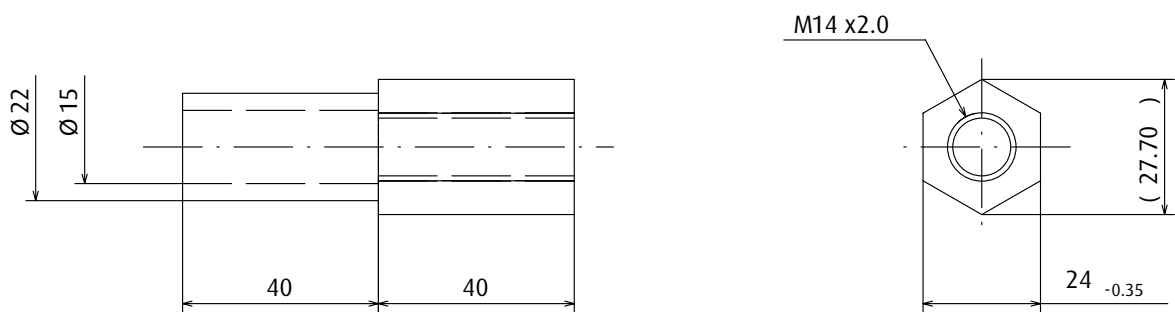

Unless otherwise specified,
the edges to be slight chamfering.
Should remove burrs and fluff.

3rd Angle Proj.

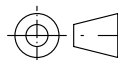

Surface Treatment	Br
Heat Treatment & Hardness	HQ-HQf HRC40 to 45
Material	S45C

Part Name

Collar

9- Service tools

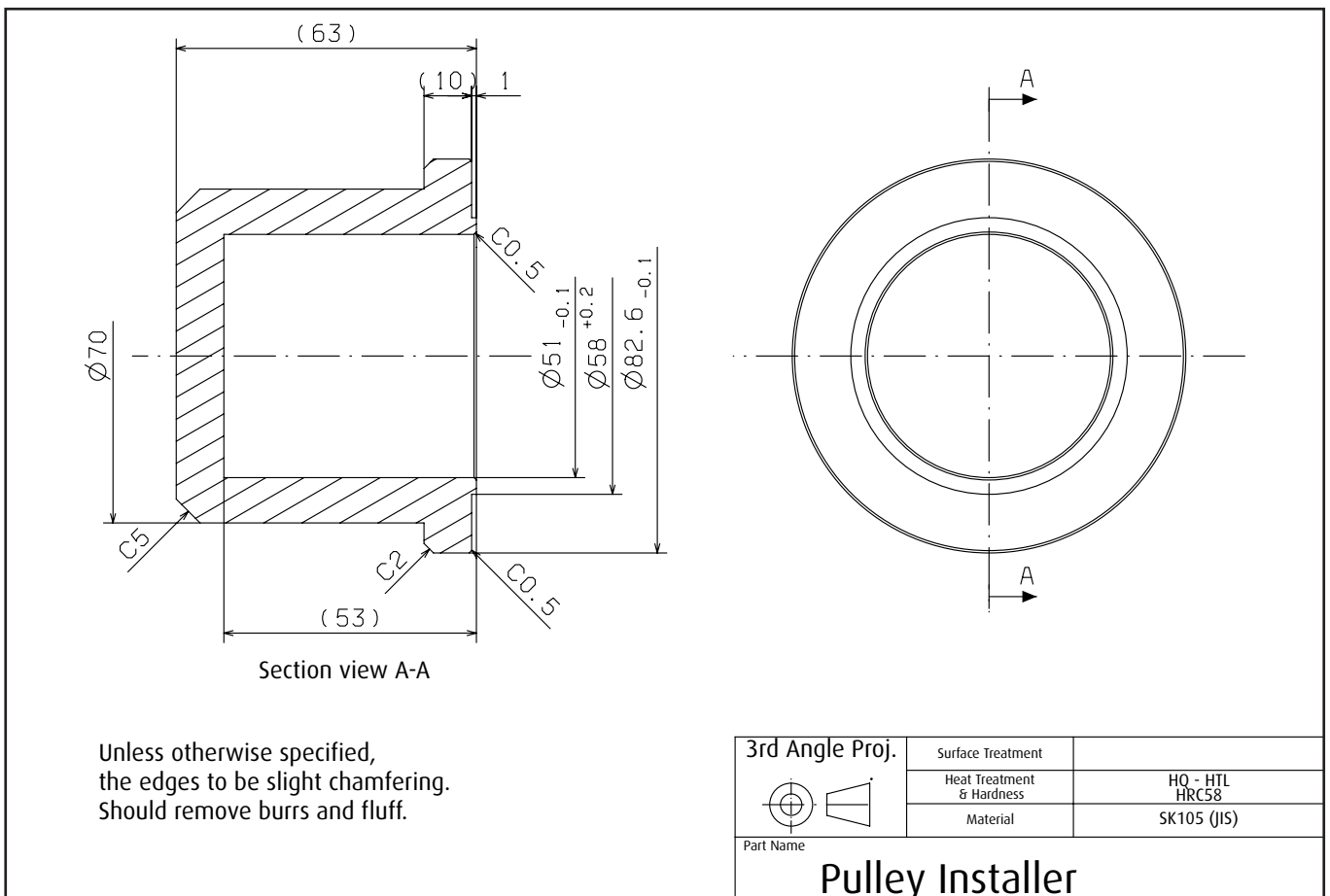
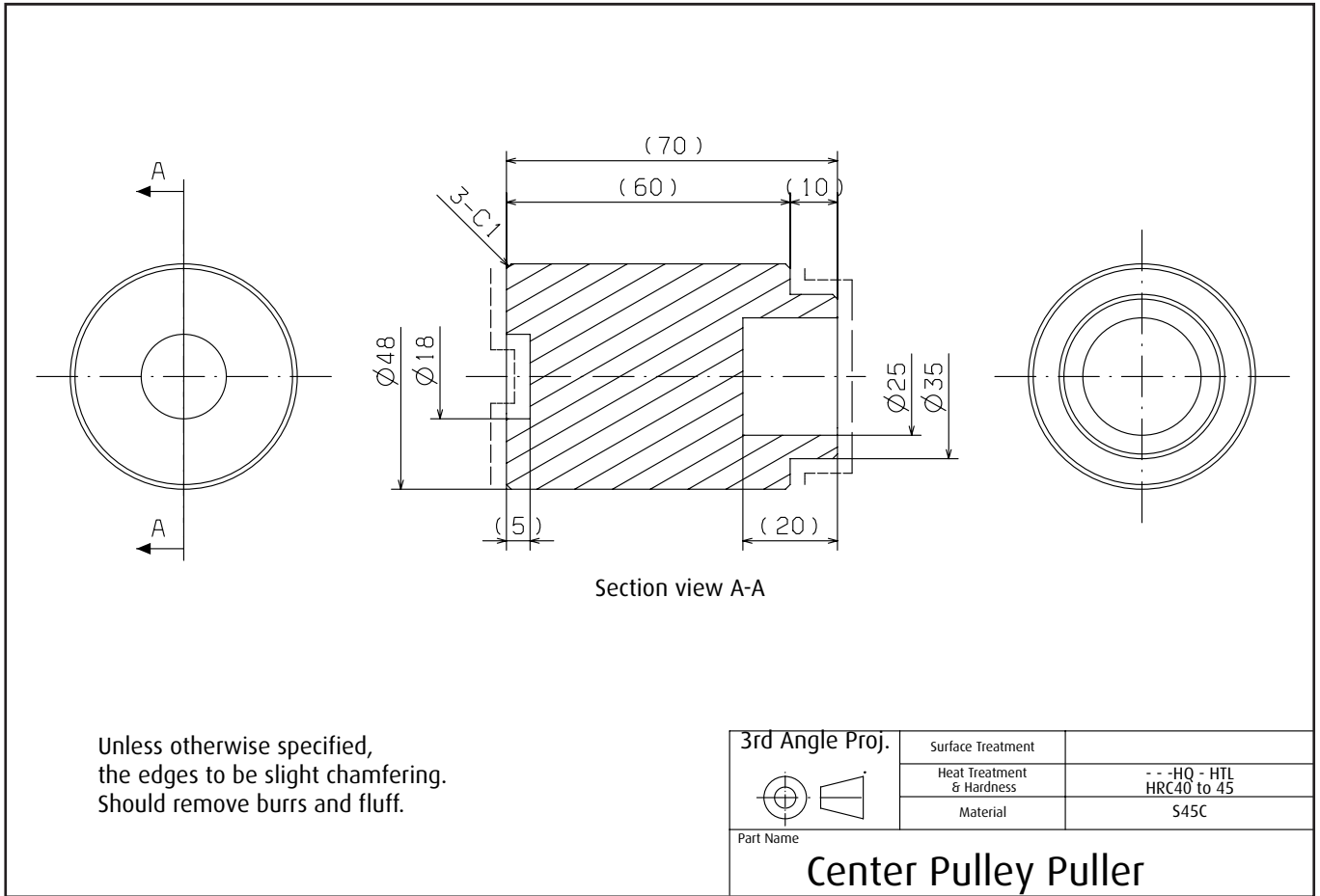

9- Service tools

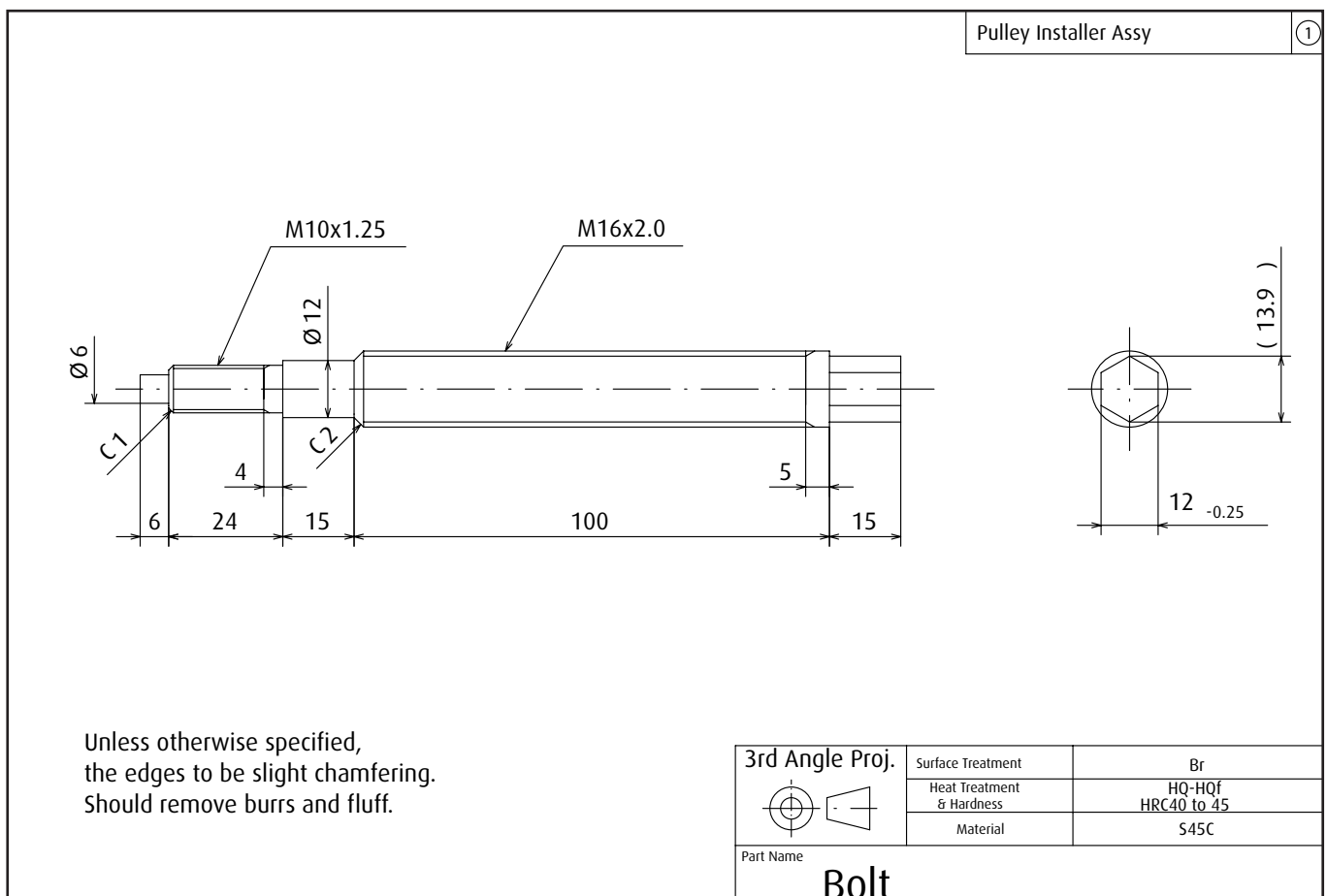
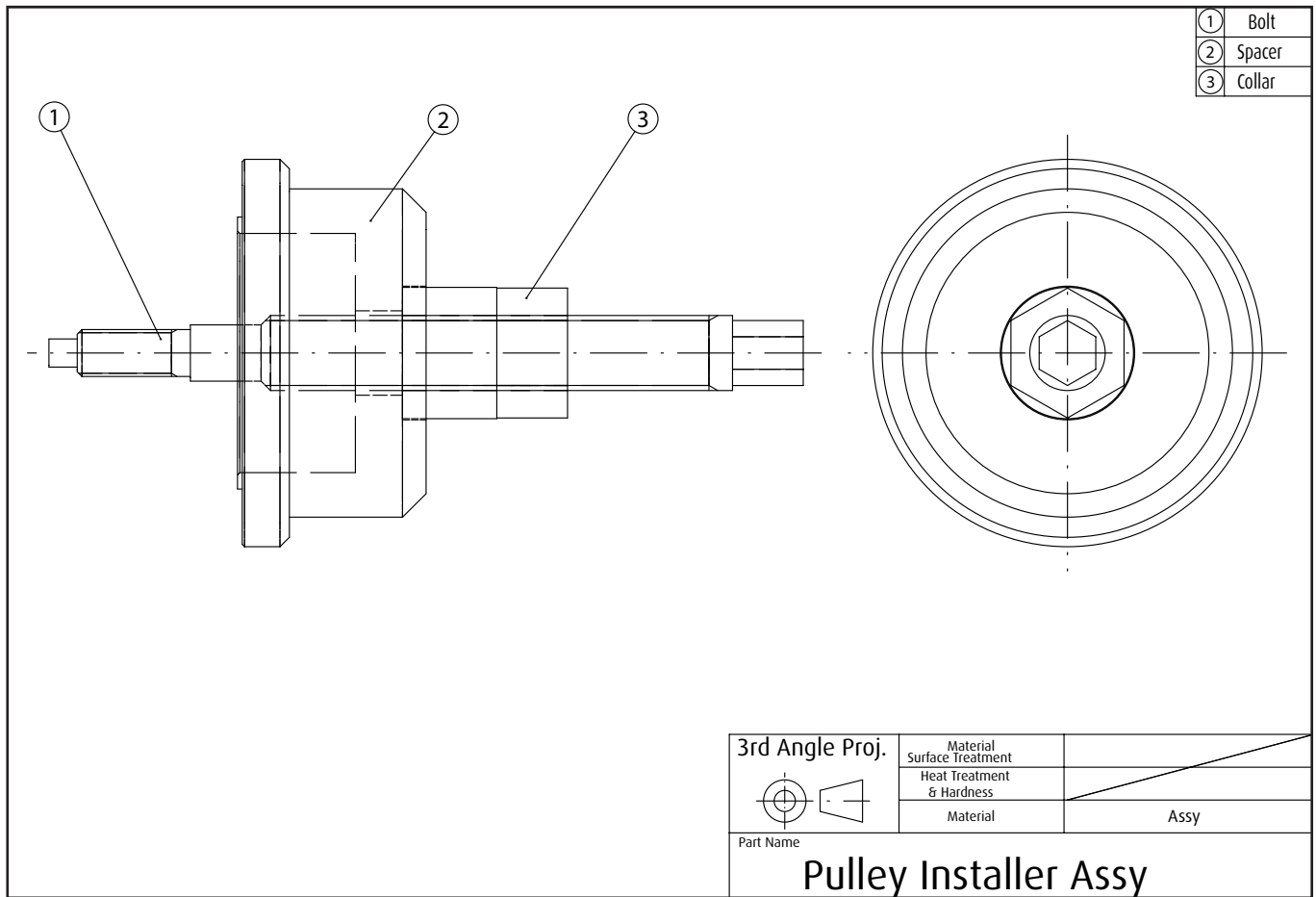

9- Service tools

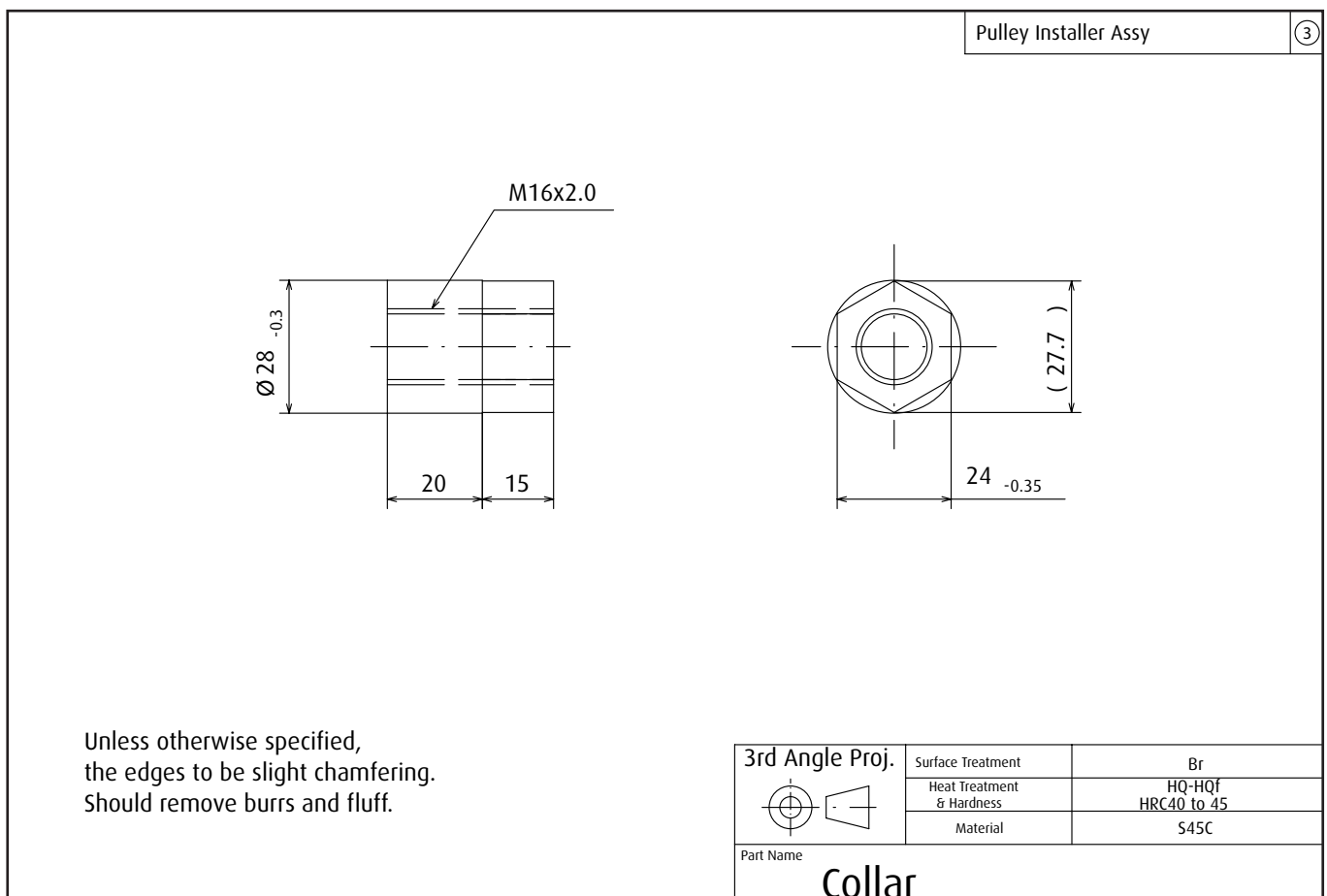
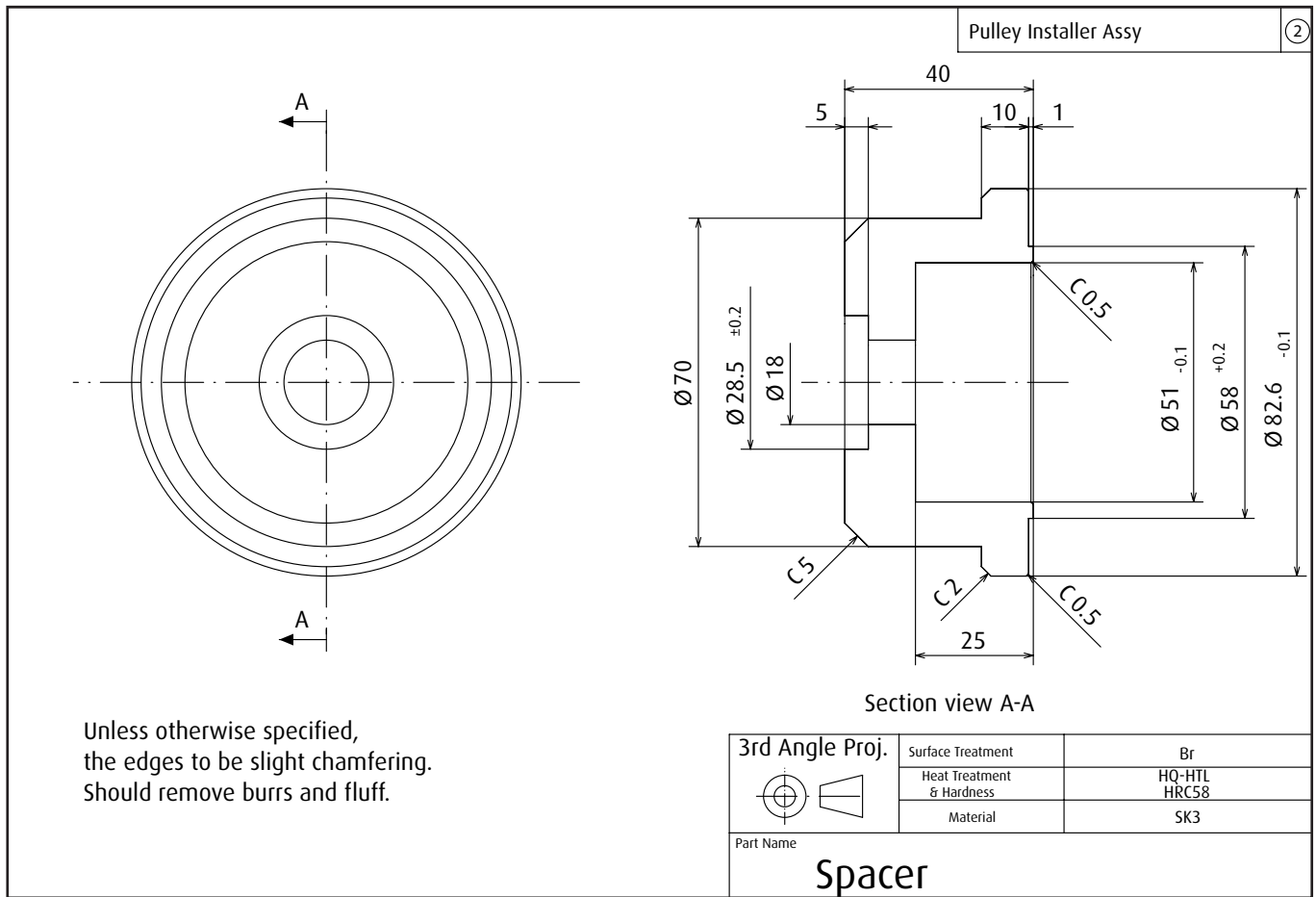

9- Service tools

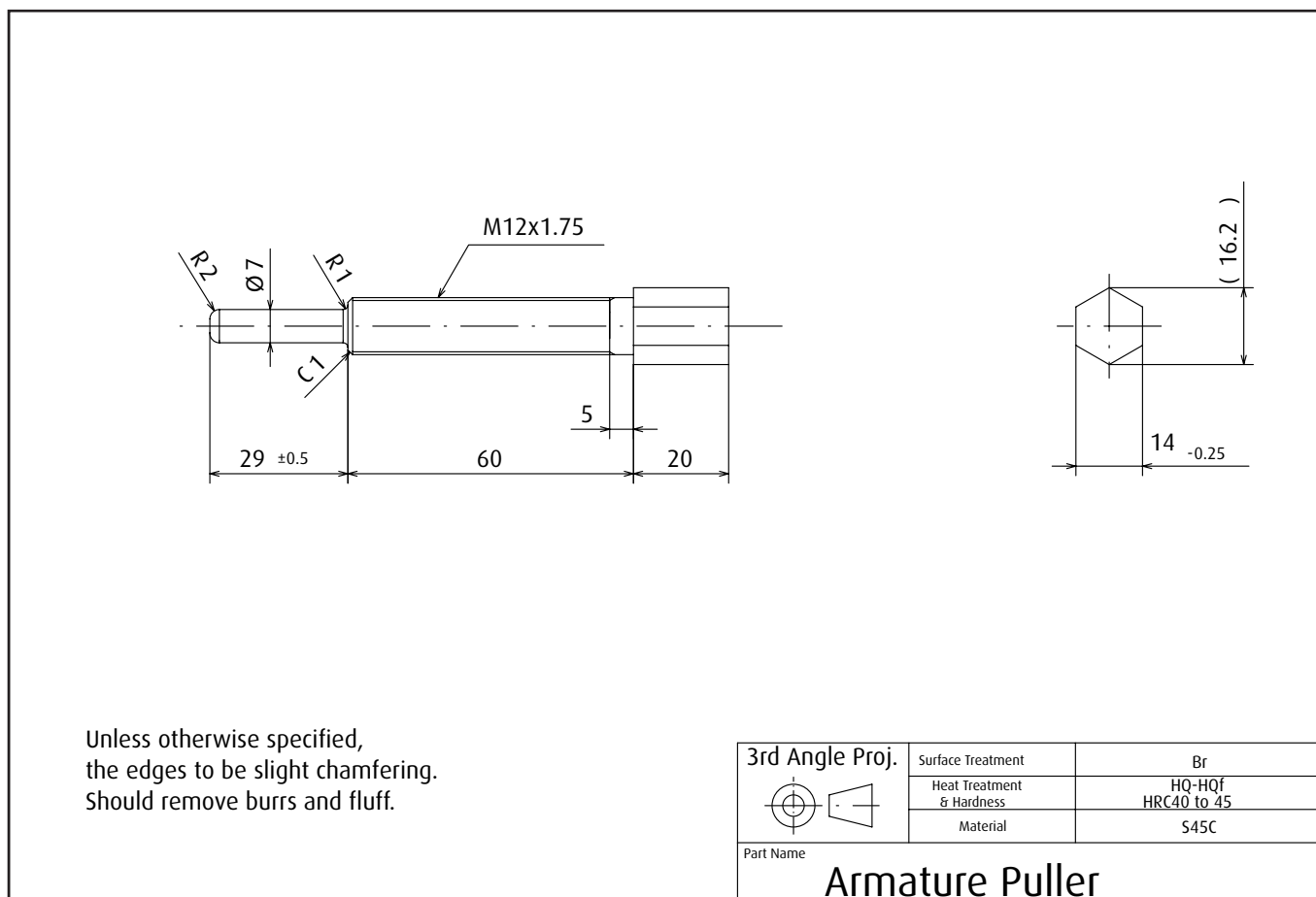
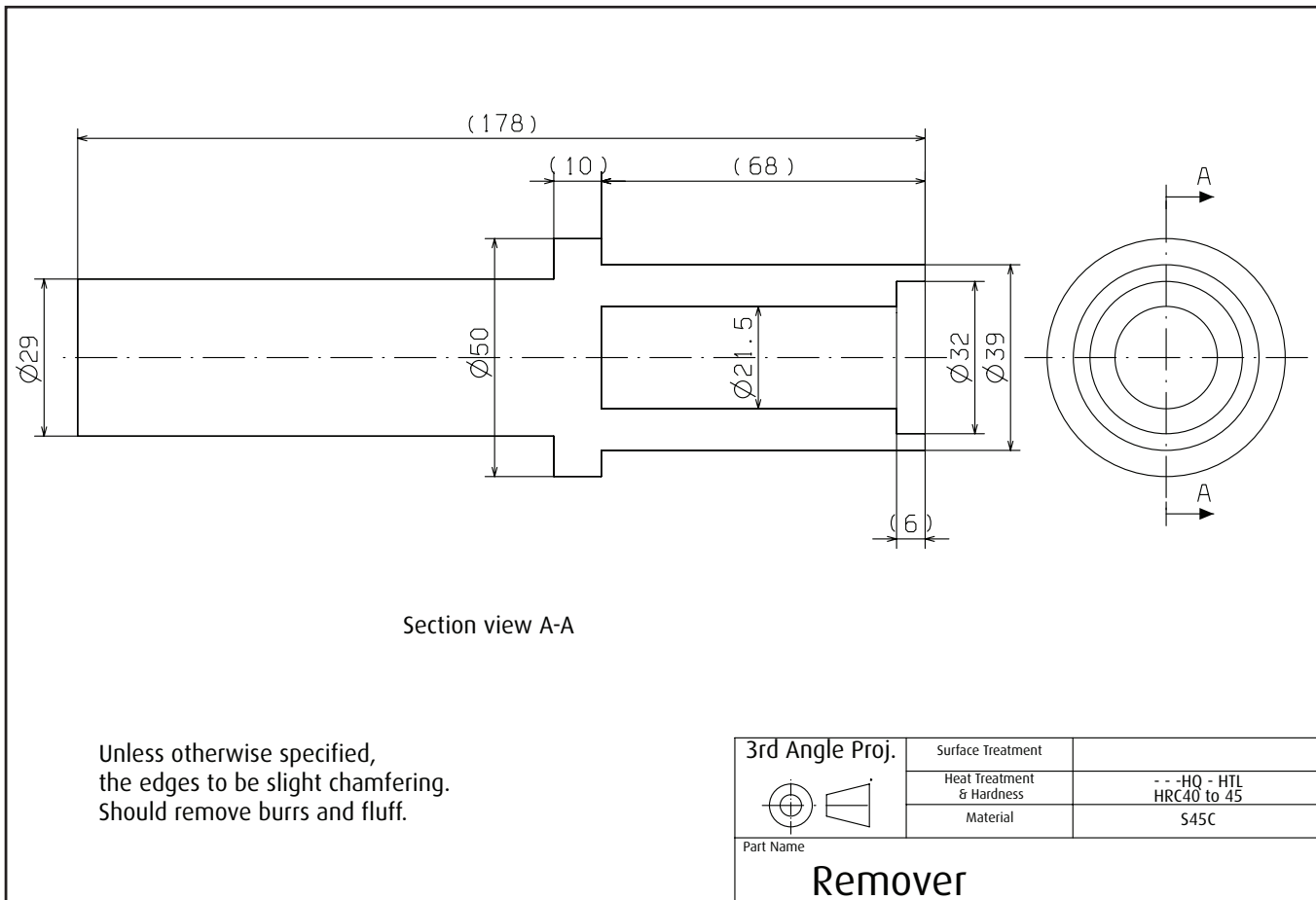

9- Service tools

①	Plate
②	Pole
③	Bolt

3rd Angle Proj. 	Surface Treatment	
	Heat Treatment & Hardness	
	Material	
Part Name Armature Puller Assy		

Armature puller assy	①
----------------------	---

Unless otherwise specified,
the edges to be slight chamfering.
Should remove burrs and fluff.

3rd Angle Proj. 	Surface Treatment	Br
	Heat Treatment & Hardness	
	Material	S45C
Part Name Plate		

9- Service tools

Armature puller assy

②

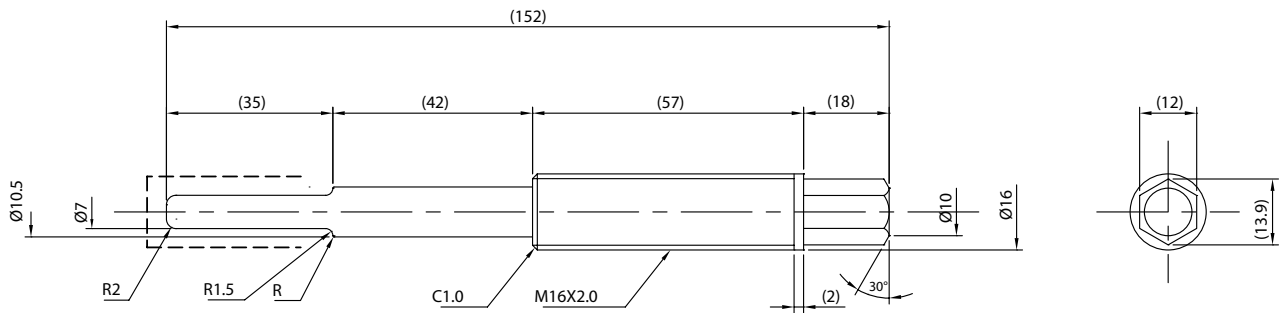

Unless otherwise specified,
the edges to be slight chamfering.
Should remove burrs and fluff.

3rd Angle Proj.

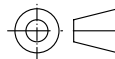

Surface Treatment

Br

Heat Treatment
& Hardness

--HQ - HQf
HRC40 to 45

Material

S45C

Part Name

Pole

Armature puller assy

③

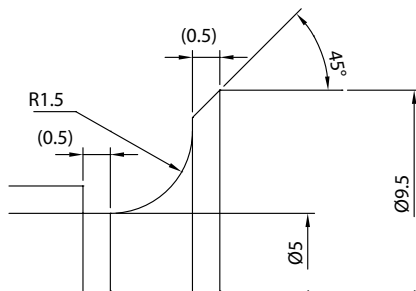

A section detailed view
(10/1)

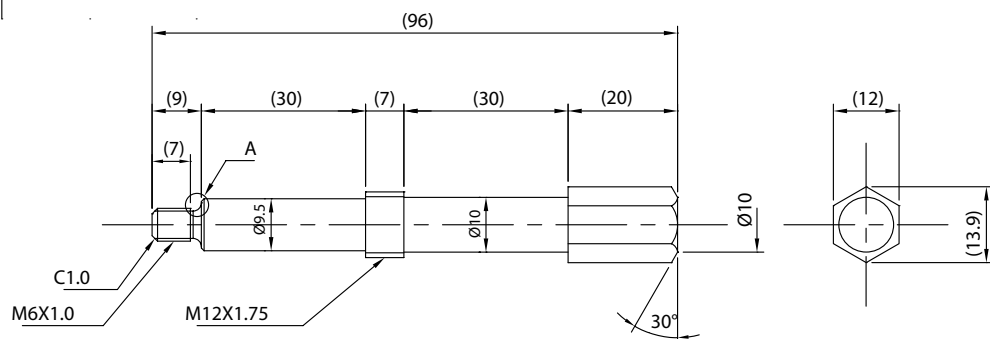

Unless otherwise specified,
the edges to be slight chamfering.
Should remove burrs and fluff.

3rd Angle Proj.

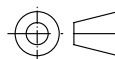

Surface Treatment

Br

Heat Treatment
& Hardness

--HQ - HQf
HRC40 to 45

Material

S45C

Part Name

Bolt

10- Service parts

1. Compressor body service kits, sets and parts

Item*	Part name	Reference	Quantity
OVERHAUL KIT (O-RING SET + GASKET SET + SHAFT SEAL)		Z0014427	-
O-RING SET		Z0014430	-
12	O-ring body (front & rear head)	Z0004833	n=2
20	O-ring drain	569300-4000	n=1
GASKET SET		Z0014431	-
13	Gasket front head	Z0004779	n=1
31	Gasket rear head	Z0004780	n=1
9	Gasket (bolt) 9 per set	569310-6200	n=9
SHAFT SEAL (for service)		-	-
11	Shaft seal	Z0007461	n=1
OTHER COMPRESSOR PARTS		-	-
14	Valve plate assy (front)	Z0004775	n=1
30	Valve plate assy (rear)	Z0004777	n=1
15	Suction valve	Z0004774	n=1

*See Product description - Exploded view (p.10)

2. Connector assy (Z0011222) service parts

Item*	Part name	Reference	Quantity	Remarks
24	Connector (body)	Z0011223	n=1	Dis./Suc.
23	Gasket	Z0011226	n=1	For conn.
26	Gasket	Z0011227	n=1	For piping
25	Bolt	Z0011228	n=2	For conn.

*See Product description - Exploded view (p.10)

3. Oil

Item	Part name	Reference	Quantity
-	ZXL 100PG (250 cc)	569900-0600	250 cc

VALEO COMPRESSORS - **TM55 & TM65** for HFC-134a use
SERVICE MANUAL

Version: SM5565-13012.01EN

Published by: VALEO JAPAN CO, LTD.

Printed in Japan

Copyright 2013, VALEO JAPAN CO, LTD.

For any inquiry regarding the present service manual,
contact us at vc-oura-sales@valeo.com

Valeo **TM55** & **TM65** Compressors for Bus Air-Conditioning

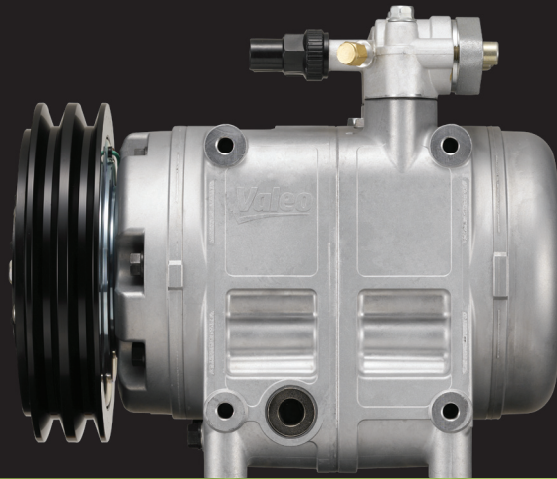

Valeo **TM55** & **TM65** Benefits

- High reliability
- Integration flexibility
- Great cooling capacity
- Enhanced performance
- Lower fuel consumption
- Compact & robust design
- Improved field serviceability
- Reduced noise and vibrations
- Staggering value through innovation

valeo added 

www.valeocompressors.com

Asia

39 Sendai, Kumagaya-shi
Saitama-ken 360-0193 Japan
Phone: +81 (0) 48 539 3800
Fax: +81 (0) 48 539 3843
Email: vc-oura-sales@valeo.com

China

No.2677 Shiji Avenue, Eco. & Tec. Dvt
Zone 130031 Changchun, Jilin PRC
Phone: +86 (0) 431 8499 2025
Fax: +86 (0) 431 8499 2004
Email: vc-changchun-sales@valeo.com

Europe, Middle East & Africa

8, rue Louis Lormand ZA de l'Agiot
78321 La Verriere, France
Phone: +33 (0) 1 3013 5027
Fax: +33 (0) 1 3461 5898
Email: vc-angers-sales@valeo.com

Americas

2520 Esters Blvd #100
Dallas, TX 75261 United States
Phone: +1 972 456 1077
Fax: +1 972 456 1090
Email: vc-dallas-sales@valeo.com