

Bill of Materials Listing

TransArctic Canada Inc.

12/21/2022
Page 1 of 1

Product Number		Date		Description		Uof M	Weight	Yield	
Line	Qty	Component	Prod#	Rev#	Description	Location	Unit		
KCB84064			09/16/13	1	Kit, Compressor, 24V, FK40/ 4xFC, '13			62.76	0
10	2	BEL11040			Belt, A gr, 1040mm (41")		each		
20	1	BMC83114		0	Bkt, PI, ALT Spacer, T3RE, '13		each		
30	2	BMN80008		1	Vibration Isolator, Bar, 16.50 x 2 x 1.50		each		
40	1	BMN80025		0	Bkt, Back, PL, Slide, IC, RE300		each		
50	2	BMT10011		0	Bkt, Tenr, Block, Offset, 3mm		each		
60	1	BMZ00043		3	Bkt, Main, Base PI, '13		each		
70	1	KBT84064		0	Kit, Platform, 4xFCY W/ Alt, '13		each		
80	1	PUL03321		1	Pulley, ALT, Idler, 3.25"d, 2A		each		
85	1	KBA84064		0	Bag Kit, ALT Shim, KC84064, KAC65501/02		each		
90	1	TRD08120			Threaded, Rod, 1/2-13unc x 12", 5, Plt		each		
100	1	KBZ84064		0	Bag Kit, Fasteners, KCB84064		each		

NOTE:

1) Use KBA84064 "Shim bag kit", as required, to align the Alternator correctly.

8 7 6 5 4 3 2 1

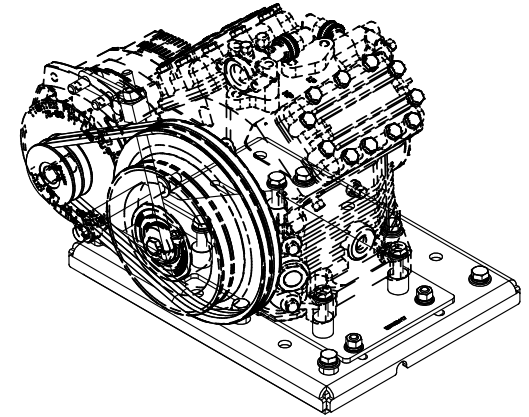
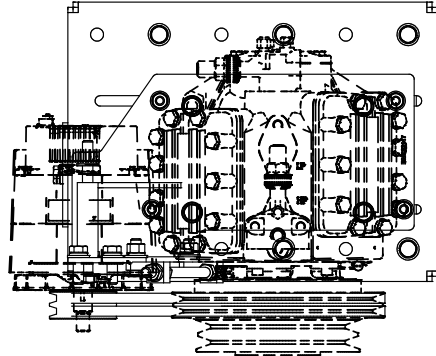
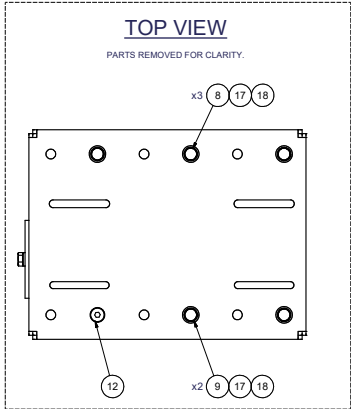

ISOMETRIC VIEW

NOTE:
SHOWING COMPRESSOR
4xFCY OR
FK40 xxxx
AS REFERENCE.

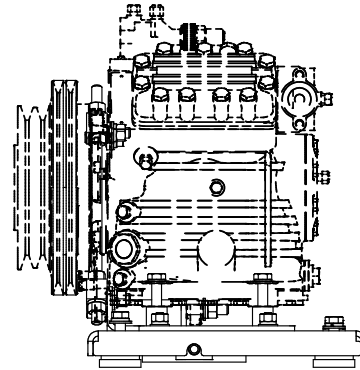

NOTES:
1) USE SERVICABLE THREADLOCKER ON ALL FASTENERS TO ENGINE COMPONENTS AND TORQUE ALL BOLTS TO S.A.E. SPECIFICATIONS.
2) SEE "TRANSARCATIC A/C COMPRESSOR MOUNT INSTALLATION DISCLAIMER".
3) WEIGHT: 56.70 LBS.

ITEM	QTY	U/M	PART NUMBER	DESCRIPTION
18	13	EACH	WLQ08000	WASHER, LOCK, 1/2", 8, PLT
17	11	EACH	WFO08000	WASHER, FLAT, 1/2", 8, PLT
16	1	EACH	TRD08120	THREADED, ROD, 1/2-13UNC x 12", 5, PLT
15	1	EACH	PUL03321	PULLEY, ALT, IDLER, 3.25", 2A
14	7	EACH	NTQ08000	NUT, HEX, 1/2-13UNC, 8, PLT
13	1	EACH	KBT84064	MT KIT, TRANSIT, 4xFCY, '12
12	1	EACH	CSF08076	CAPSCREW, FH, 1/2-20UNF x .75", ALLOY, PLT
11	1	EACH	BTQ08653	BOLT, HEX, 1/2-13UNC x 6.50, 8, PLT
10	4	EACH	BTQ08150	BOLT, HEX, 1/2-13UNC x 1.50, 8, PLT
9	2	EACH	BTQ08126	BOLT, HEX, 1/2-20UNF x 1.25, 8, PLT
8	3	EACH	BTQ08101	BOLT, HEX, 1/2-20UNF x 1.00, 8, PLT
7	1	EACH	BTQ08653	BOLT, HEX, 1/2-13UNC x 6.50, 5, PLT, FT
6	1	EACH	BMZ00043	BKT, MAIN, BASE PL, '13
5	2	EACH	BMT10011	BKT, TENR, BLOCK, OFFSET, 3mm
4	1	EACH	BMN80025	BKT, BACK, PL, SLIDE, IC, RE300
3	2	EACH	BMN80008	VIBRATION ISOLATOR, BAR, 16.50 x 2 x 1.50
2	1	EACH	BMC83114	BKT, PL, ALT SPACER, T3RE, '13
1	2	EACH	BEL11040	BELT, A gr, 1040mm (41")

BILL OF MATERIALS

DRAWN: jrodriquez 9/16/2013
 CHECKED: Val Jaskowlew 9/16/2013
 OR: Ron Ingram 9/16/2013
 APPROVED: Dale Mason 9/16/2013

DATE: 9/16/2013
 BY: James Stewart

THIS DRAWING CONTAINS PROPRIETARY CONFIDENTIAL INFORMATION OWNED BY TRANSARCATIC CANADA INC. THE DOCUMENT AND THE INFORMATION IN IT ARE NOT TO BE USED, DISCLOSED OR REPRODUCED WITHOUT EXPRESS WRITTEN PERMISSION OF THE COMPANY.

UNSPECIFIED TOLERANCES: ALL DIMS FINISH TO ONE DECIMAL PLACE (.X) TWO DECIMAL PLACE (.XX) THREE DECIMAL PLACE (.XXX) FRACTIONAL: 1/16" ANGLES: ± .01

THIRD ANGLE PROJECTION

DRAWING UNIT OF MEASURE: MM (INCH) SCALE: 1:3

DWG NO: KCB84064
 REV: 0

TRANSARCATIC INC.

TITLE: KIT, COMPRESSOR, 24V, FK40/ 4xFC, '13

SHEET 1 OF 1

8 7 6 5 4 3 2 1