

Bill of Materials Listing

TransArctic Canada Inc.

9/7/2006

Page 1 of 1

| Product Number | | Description | Bin | Date | Weight | Uof M | Yield |
|-----------------|-----------------|--|-----|-----------------|--------------|-------|----------|
| Line | Component Prod# | Description | | Unit | Qty | | |
| KMK72692 | | Mt Kit, C7, HDX-ER, 2 TM-21, '06 | | 2/2/2006 | 28.04 | | 0 |
| 10 | BEL82629 | Belt, 8gr, 2629mm (103.5") (5081035) | | each | 1 | | |
| 20 | BMK70064 | Bkt, Main, Weldmt, Inner, Plate | | each | 1 | | |
| 30 | BMK70065 | Bkt, Main, Weldmt, Outer, Plate | | each | 1 | | |
| 40 | BMK70067 | Bkt, Brace, Plate | | each | 1 | | |
| 60 | PUL80076 | Pulley, Idler, Backside, P8, 76d (89062) | | each | 1 | | |
| 65 | PUL80089 | Pulley, Idler, Backside, P8, 86.4d (89106) | | each | 1 | | |
| 70 | SCD12710 | Spacer, Col, Drl, 12.7mm x 25.4o x 10.32i | | each | 2 | | |
| 80 | SLV17010 | Sleeve, Pulley, 16.9o x 22.23mm x 10.32i | | each | 2 | | |
| 90 | HOR02004 | Hose, Rad, 2" ID, Long, 90 deg | | each | 1 | | |
| 120 | KBK72692 | Bag Kit, Fasteners, KMK72692/2092 | | each | 1 | | |

Bill of Materials Listing

TransArctic Canada Inc.

9/7/2006

Page 1 of 1

| Product Number | | Description | Bin | Date | Weight | Uof M | Yield |
|-----------------|-----------------|--|-----|-----------------|-------------|-------|----------|
| Line | Component Prod# | Description | | Unit | Qty | | |
| KBK72692 | | Bag Kit, Fasteners, KMK72692/2092 | | 2/2/2006 | 1.54 | | 0 |
| 5 | BTC10065 | Bolt, Hex, 10 x 1.5 x 65mm, 10.9, Plt | | each | 2 | | |
| 10 | BTC10040 | Bolt, Hex, 10 x 1.5 x 40mm, 10.9, Plt | | each | 2 | | |
| 20 | BTC10030 | Bolt, Hex, 10 x 1.5 x 30mm, 10.9, Plt | | each | 2 | | |
| 30 | BTC10025 | Bolt, Hex, 10 x 1.5 x 25mm, 10.9, Plt | | each | 1 | | |
| 40 | BTC10020 | Bolt, Hex, 10 x 1.5 x 20mm, 10.9, Plt | | each | 1 | | |
| 50 | BTC08100 | Bolt, Hex, 8 x 1.25 x 100mm, 10.9, Plt | | each | 8 | | |
| 70 | BTC08020 | Bolt, Hex, 8 x 1.25 x 20mm, 10.9, Plt | | each | 6 | | |
| 100 | WFA08000 | Washer, Flat, 8mm, 8.8, Plt | | each | 8 | | |
| 110 | WLA10000 | Washer, Lock, 10mm, 8.8, Plt | | each | 8 | | |
| 120 | WLA08000 | Washer, Lock, 8mm, 8.8, Plt | | each | 14 | | |

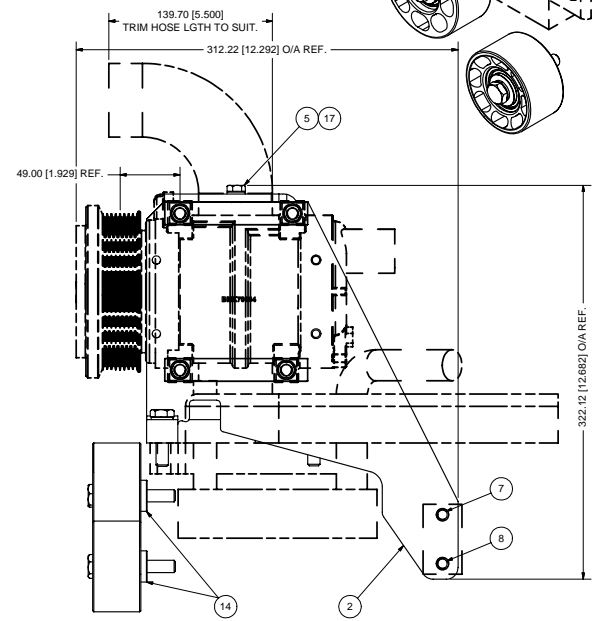
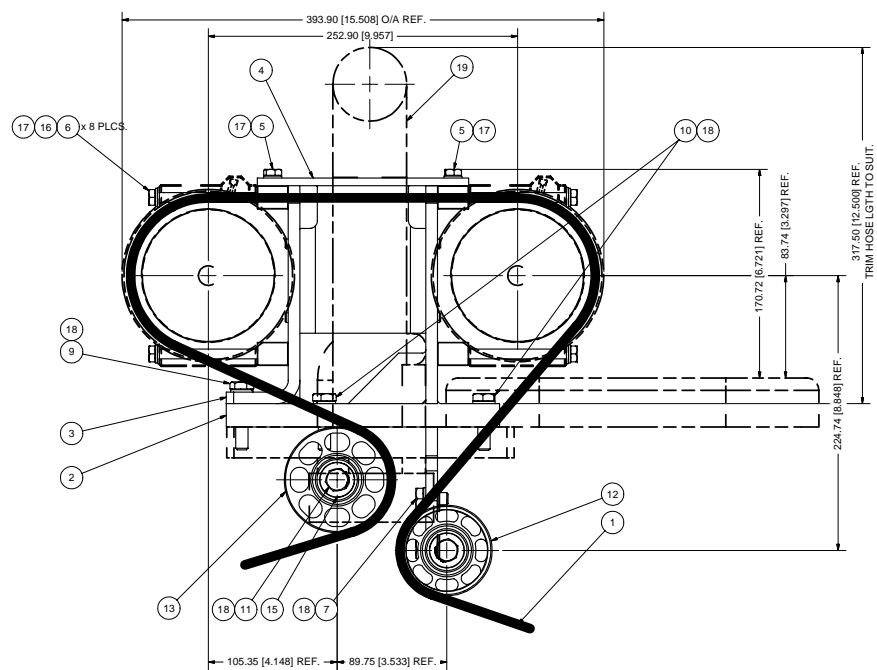
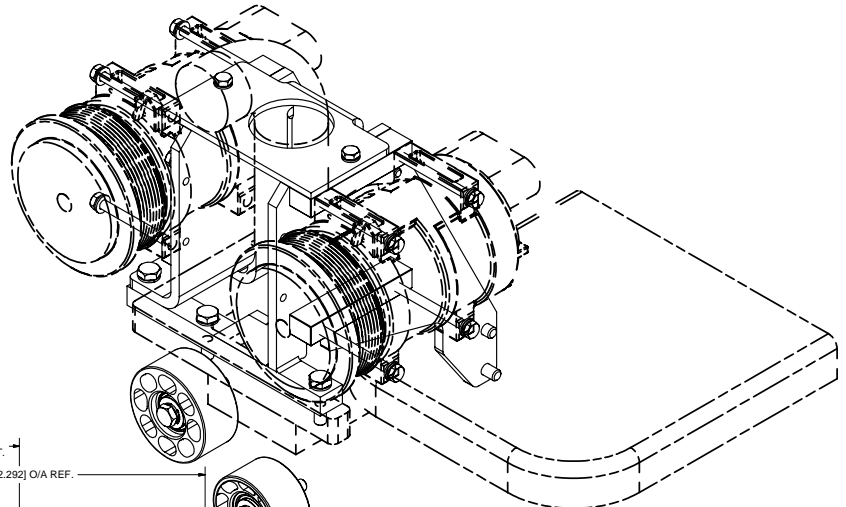
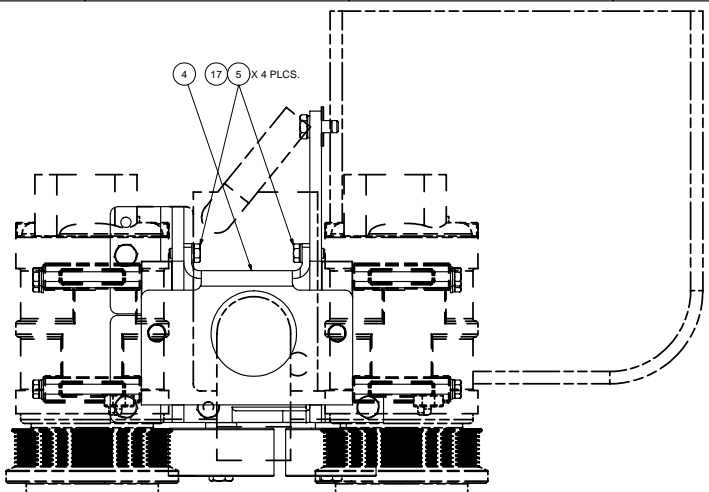

NOTES:
 1) USE SERVICABLE THREADLOCKER ON ALL FASTENERS TO ENGINE COMPONENTS AND TORQUE ALL BOLTS TO S.A.E. SPECIFICATIONS.
 2) SEE "TRANSARCTIC A/C COMPRESSOR MOUNT INSTALLATION DISCLAIMER".

| ITEM | QTY | UM | PART NUMBER | DESCRIPTION |
|------|-----|------|-------------|---|
| 19 | 1 | EACH | HOR02004 | HOSE, RAD, 2" ID, LONG, 90 DEG |
| 18 | 8 | EACH | WLA10000 | WASHER, LOCK, 10mm, 8.8, PLT |
| 17 | 14 | EACH | WLA08000 | WASHER, LOCK, 8mm, 8.8, PLT |
| 16 | 8 | EACH | WFA08000 | WASHER, FLAT, 8mm, 8.8, PLT |
| 15 | 2 | EACH | SLV17010 | SLEEVE, PULLEY, 16.9x x 22.23mm x 10.32 |
| 14 | 2 | EACH | SCD12710 | SPACER, COIL, DRL, 12.7mm x 25.4x10.32 |
| 13 | 1 | EACH | PUL80089 | PULLEY, IDLER, BACKSIDE, P8, 86.4D, 39W |
| 12 | 1 | EACH | PUL80076 | PULLEY, IDLER, BACKSIDE, P8, 76D, 39W |
| 11 | 2 | EACH | BTC10065 | BOLT, HEX, 10 x 1.5 x 65mm, 10.9, PLT |
| 10 | 2 | EACH | BTC10040 | BOLT, HEX, 10 x 1.5 x 40mm, 10.9, PLT |
| 9 | 2 | EACH | BTC10030 | BOLT, HEX, 10 x 1.5 x 30mm, 10.9, PLT |
| 8 | 1 | EACH | BTC10025 | BOLT, HEX, 10 x 1.5 x 25mm, 10.9, PLT |
| 7 | 1 | EACH | BTC10020 | BOLT, HEX, 10 x 1.5 x 20mm, 10.9, PLT |
| 6 | 8 | EACH | BTC08100 | BOLT, HEX, 8 x 1.25 x 100mm, 10.9, PLT |
| 5 | 6 | EACH | BTC08020 | BOLT, HEX, 8 x 1.25 x 20mm, 10.9, PLT |
| 4 | 1 | EACH | BMK70067 | BKT, BRACE, PLATE |
| 3 | 1 | EACH | BMK70065 | BKT, MAIN, WELDMT, OUTER, PLATE |
| 2 | 1 | EACH | BMK70064 | BKT, MAIN, WELDMT, INNER, PLATE |
| 1 | 1 | EACH | BEL82629 | BELT, 8gr, 2629mm (103.5") (5081035) |

TRANSARCTIC INC.

| | | | | | |
|----------|-------------------------|-----------|---------------|----------|----------|
| 1 | ADDED HOR02004 HOSE EXT | 5/30/2006 | VALJ | Checked | 3/8/2006 |
| 2 | RELEASED TO PRODUCTION | 3/8/2006 | VALJ | Checked | 3/8/2006 |
| REVISION | DESCRIPTION | DATE | BY | APPROVED | |
| | | | James Stewart | | 3/8/2006 |
| | | | Val Jakovlew | | 3/8/2006 |
| | | | Dale Mason | | 3/8/2006 |

UNSPECIFIED TOLERANCES:
 DIM DECIMAL PLACE (X) .00 (X) .00 (X) .00
 DIM FRACTIONAL PLACE (X) .00 (X) .00 (X) .00
 FRACTIONAL (1/32) ANGULAR ± .25°

DRAWING UNIT OF MEASURE: MM (INCH)
 SCALE: 1:1
 SHEET 1 OF 1

MT KIT, C7, HDX-ER, 2 TM-21, '06

DWG NO: KMK72692
 REV: 1

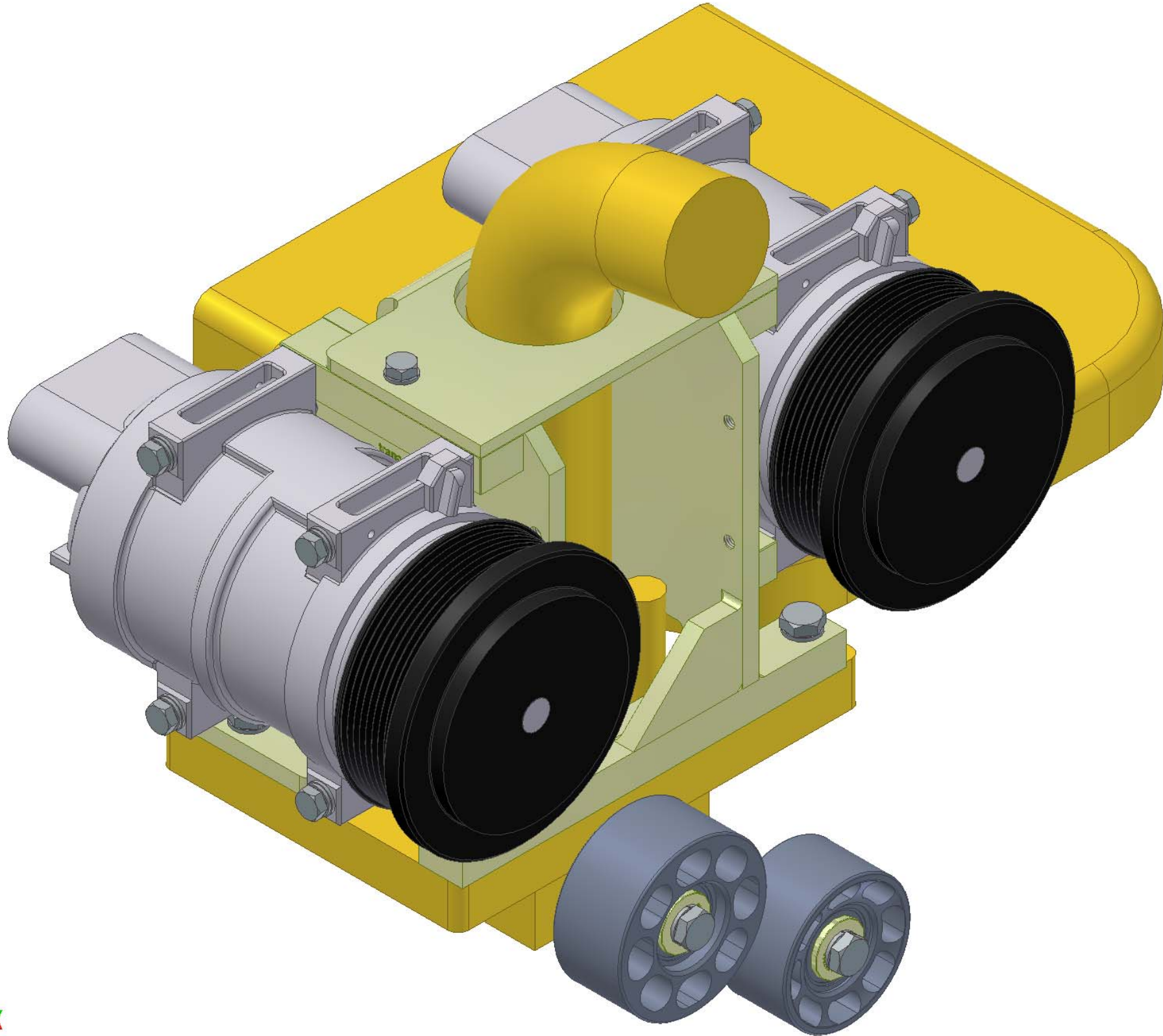

TransArctic A/C Compressor Mount Installation Disclaimer

All compressor mounts should be installed by qualified and trained personnel using proper tools and equipment in safe working conditions following industry standard guidelines for motor vehicle service and repair.

The installer of any compressor mount purchased from TransArctic must undertake all responsibility of issues arising from that compressor bracket being installed on any vehicle. Mount functionality, operation and durability can all be compromised by an incompetent installation.

Due to the many different situations, parameters and application criteria, which are beyond the compressor mount manufacturer's control, TransArctic does not warrant design, durability, or operational functionality of any compressor mount improperly installed by another party.

With no implied guarantees it is the mount installer's strict responsibility to determine safety and functionality, of the compressor mount, at the time of installation.

Please contact TransArctic with any issue arising from installation so we may better improve the product. If you have any reservations about the compressor mount integrity contact TransArctic immediately at 1-877-COLD-AIR.