

ISOMETRIC VIEW

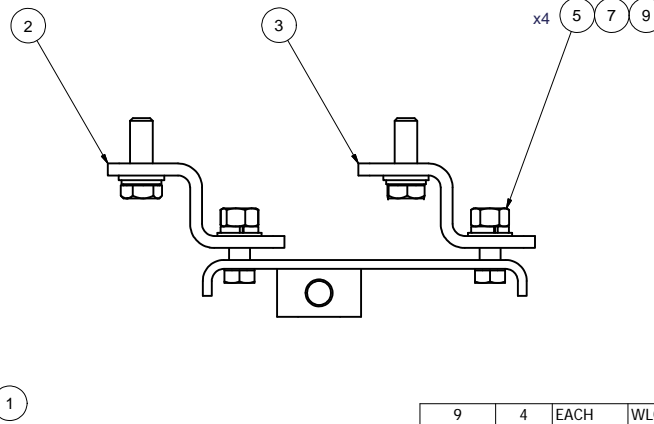
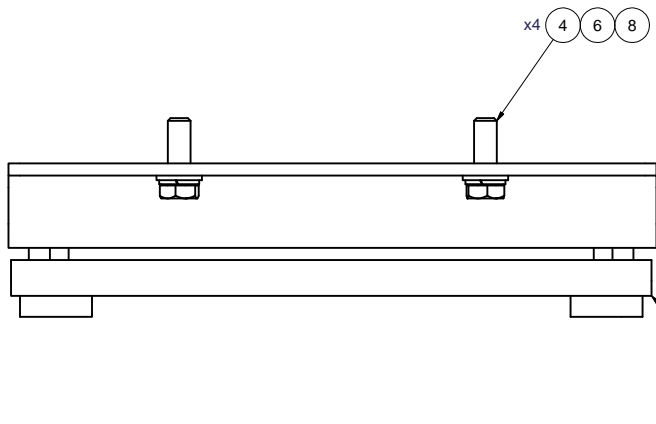

ITEM	QTY	U/M	PART NUMBER	DESCRIPTION
9	4	EACH	WLQ07000	WASHER, LOCK, 7/16", 8, PLT
8	4	EACH	WLA12000	WASHER, LOCK, 12mm, 8.8, PLT
7	4	EACH	WFO07000	WASHER, FLAT, 7/16", 2, PLT
6	4	EACH	WFA12000	WASHER, FLAT, 12mm, 8.8, PLT
5	4	EACH	NTP07000	NUT, HEX, 7/16-14UNC, 5, PLT
4	4	EACH	BTC12035	BOLT, HEX, 12 x 1.75 x 35mm, 10.9, PLT
3	1	EACH	BMZ00057	BKT, COMP, REAR, Z, TM-65/55, '13
2	1	EACH	BMZ00056	BKT, COMP, FRT, Z, TM-65/55, '13
1	1	EACH	BMN80031	BKT, MAIN, SLIDE, ASSY, 05K, IC, RE300

BILL OF MATERIALS

DRAWN	jrodriguez	8/8/2016
CHECKED	Val Jakowlew	8/8/2016
APPROVED	James Stewart	8/8/2016
MFG	James Stewart	8/8/2016
APPROVED	Dale Mason	8/8/2016

**TRANSARCTIC INC.**

TITLE  
**KIT, PLATFORM, P/S, TM-55/65, '16**

SIZE: **C** DWG NO: **KBT65501** REV: **0**

0	RELEASED TO PRODUCTION	8/8/2016	JRR
REV	ECN	DESCRIPTION	DATE
<small>THIS DRAWING CONTAINS PROPRIETARY CONFIDENTIAL INFORMATION OWNED BY TRANSARCTIC CANADA INC. THE DOCUMENT AND THE INFORMATION IN IT ARE NOT TO BE USED, DISCLOSED OR REPRODUCED WITHOUT EXPRESS WRITTEN PERMISSION OF THE COMPANY.</small>			
<small>UNSPECIFIED TOLERANCES: (ALT. DIM.)</small>			
ONE DECIMAL PLACE (.X)	MM (.50)	(.020)	
TWO DECIMAL PLACE (.XX)	MM (.25)	(.010)	
THREE DECIMAL PLACE (.XXX)	MM (.10)	(.005)	
FRACTIONAL +/- .102"	ANGULAR +/- .50°		
DRAWING UNIT OF MEASURE: MM (INCH)			

NOTES:

- 1) USE SERVICABLE THREADLOCKER ON ALL FASTENERS TO ENGINE COMPONENTS AND TORQUE **ALL** BOLTS TO S.A.E. SPECIFICATIONS.
- 2) SEE "TRANSARCTIC A/C COMPRESSOR MOUNT INSTALLATION DISCLAIMER".
- 3) WEIGHT: 16.47 LBS.