

Bill of Materials Listing

TransArctic Canada Inc.

5/20/2005

Page 1 of 1

Product Number		Description	Bin	Date	Weight	Uof M	Yield
Line	Component Prod#	Description		Unit	Qty		
KMK72672		Mt Kit, C7, FS65, 2 TM-21, P8-OEM		6/4/2004	10.51		0
10	BEL83023	Belt, 8gr, 3023mm (119.0") (5081190)		each	1		
20	BMK70037	Bkt, Main, Weldmt, C7, TH MVP-EF, P8		each	1		
30	BMK70038	Bkt, Brace, RR P/S, C7, TH MVP-EF, P8		each	1		
40	BMK70039	Bkt, Brace, Diag D/S, C7, TH MVP-EF, P8		each	1		
50	BMK70040	Bkt, Strap, Tie, P/S, C7, TH MVP-EF, P8		each	1		
60	BMS70005	Bkt, Cradle,L/H,TM-21,92mm,90/ccw,MVP EF		each	2		
70	BMS70006	Bkt, Cradle,R/H,TM-21,87mm,90/ccw,MVP EF		each	2		
80	PUL80076	Pulley, Idler, Backside, P8, 76d (89062)		each	1		
90	TUS02091	Tube, Stl, Exh, 2"o.d., 90 deg elb,12x7		each	1		
100	KBK72680	Bag Kit, Fasteners, KMK72680/72/1980/72		each	1		

Bill of Materials Listing

TransArctic Canada Inc.

9/7/2006
Page 1 of 1

Product Number		Description	Bin	Date	Weight	Uof M	Yield
Line	Component Prod#	Description		Unit	Qty		
KBK72680		Bag Kit, Fasteners, KMK72680/72/1980/72		9/21/2004	1.95		0
10	BTS10001	Bolt, Shoulder, 10mm (89064)		each	1		
30	BTC10055	Bolt, Hex, 10 x 1.5 x 55mm, 10.9, Plt		each	2		
35	BTC10040	Bolt, Hex, 10 x 1.5 x 40mm, 10.9, Plt		each	1		
40	BTC10035	Bolt, Hex, 10 x 1.5 x 35mm, 10.9, Plt		each	2		
50	BTC10030	Bolt, Hex, 10 x 1.5 x 30mm, 10.9, Plt		each	7		
60	BTC10025	Bolt, Hex, 10 x 1.5 x 25mm, 10.9, Plt		each	3		
70	BTC08100	Bolt, Hex, 8 x 1.25 x 100mm, 10.9, Plt		each	8		
100	NTA10000	Nut, Hex, 10 x 1.5, 8.8, Plt		each	1		
120	WDS17001	Washer, Dust Cover (89060)		each	1		
130	WFA10000	Washer, Flat, 10mm, 8.8, Plt		each	3		
140	WFA08000	Washer, Flat, 8mm, 8.8, Plt		each	8		
160	WLA10000	Washer, Lock, 10mm, 8.8, Plt		each	14		
170	WLA08000	Washer, Lock, 8mm, 8.8, Plt		each	8		
190	CLP36001	Clamp, Gear, #36, 1 13/16-2 3/4 (46/70mm)		each	2		
200	CLP20040	Clamp, "P" type, #40, 1/2"w, 2 1/2", PC		each	1		
210	CLP20028	Clamp, "P" type, #28, 1/2"w, 1 3/4", PC		each	1		
220	CLP20016	Clamp, "P" type, #16, 1/2"w, 1", PC		each	1		

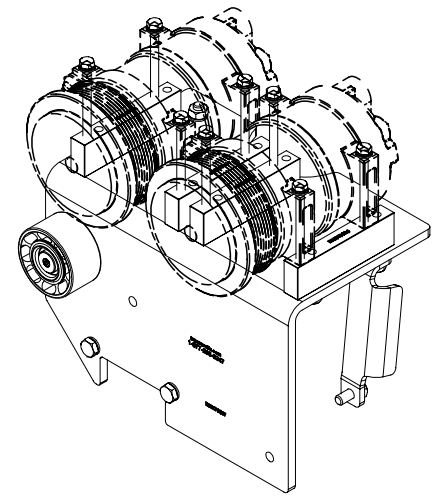
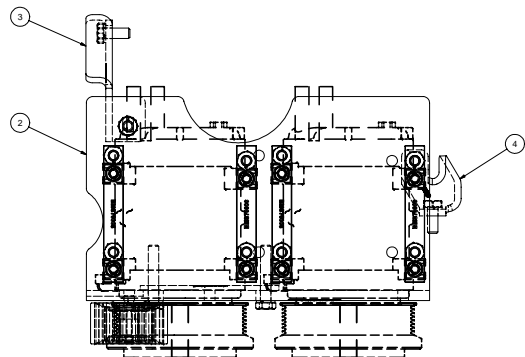

ISOMETRIC VIEW

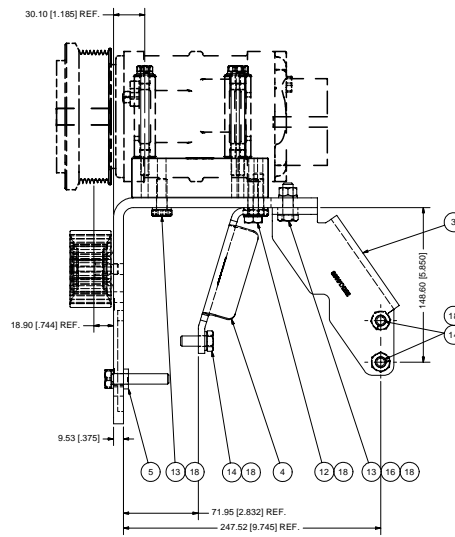
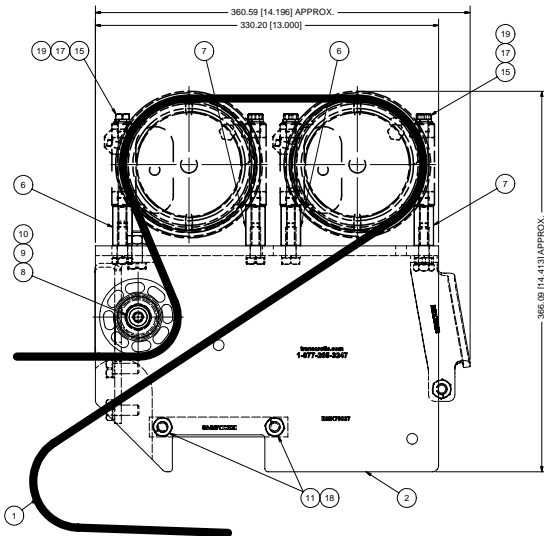

- NOTES:
1) USE SERVICABLE THREADLOCKER ON ALL FASTENERS TO ENGINE COMPONENTS AND TORQUE ALL BOLTS TO S.A.E. SPECIFICATIONS.
2) SEE "TRANSARCTIC A/C COMPRESSOR MOUNT INSTALLATION DISCLAIMER".

ITEM	QTY	U/M	PART NUMBER	DESCRIPTION
19	8	EACH	WLA08000	WASHER, LOCK, 8mm, 8.8, PLT
18	14	EACH	WLA10000	WASHER, LOCK, 10mm, 8.8, PLT
17	8	EACH	WFA08000	WASHER, FLAT, 8mm, 8.8, PLT
16	1	EACH	NTA10000	NUT, HEX, 10 x 1.5, 8.8, PLT
15	8	EACH	BTC08100	BOLT, HEX, 8 x 1.25 x 100mm, 10.9, PLT
14	3	EACH	BTC10025	BOLT, HEX, 10 x 1.5 x 25mm, 10.9, PLT
13	7	EACH	BTC10030	BOLT, HEX, 10 x 1.5 x 30mm, 10.9, PLT
12	2	EACH	BTC10035	BOLT, HEX, 10 x 1.5 x 35mm, 10.9, PLT
11	2	EACH	BTC10055	BOLT, HEX, 10 x 1.5 x 55mm, 10.9, PLT
10	1	EACH	WDS17001	WASHER, DUST COVER (PUL80076)
9	1	EACH	PUL80076	PULLEY, IDLER, BACKSIDE, P8, 76D, 39W
8	1	EACH	BTS10001	BOLT, SHOULDER, 10mm (IDLER PULLEY)
7	2	EACH	BMS70006	BKT, CRADLE, RH, TM-21, 87mm, 90/cw, MVP EF
6	2	EACH	BMS70005	BKT, CRADLE, LH, TM-21, 92mm, 90/cw, MVP EF
5	1	EACH	BMK70040	BKT, STRAP, TIE, C7, TH MVP-EF, P8
4	1	EACH	BMK70039	BKT, BRACE, DIAG, DIS, C7, TH MVP-EF, P8
3	1	EACH	BMK70038	BKT, BRACE, RR, P/S, SUP, C7, TH FS65, P8
2	1	EACH	BMK70037	BKT, MAIN, WELDMT, C7, TH MVP-EF, P8
1	1	EACH	BEL83023	BELT, 8gr, 3032mm (119.0") (5081190)

DRAWN: vjakowlew		DATE: 9/15/2005	TITLE: TRANSARCTIC INC.	
CHECKED: Ron Ingram		DATE: 9/15/2005	REV: 0	
REV: 0	RELEASED TO PRODUCTION: USA	DATE: 9/15/2005	BY: James Stewart	
REV: 1	DESCRIPTION: MT KIT, C7, TH FS65, 2 TM-21, P8	DATE: 9/15/2005	BY: Dele Mason	
MFG: USA		DATE: 9/15/2005	SIZE: F	DWG NO: KMK72672
UNSPECIFIED TOLERANCES:		THIRD ANGLE PROJECTION		
DRAWING UNIT OF MEASURE: MM INCH		SCALE: 1:2	SHEET: 1	OF: 1

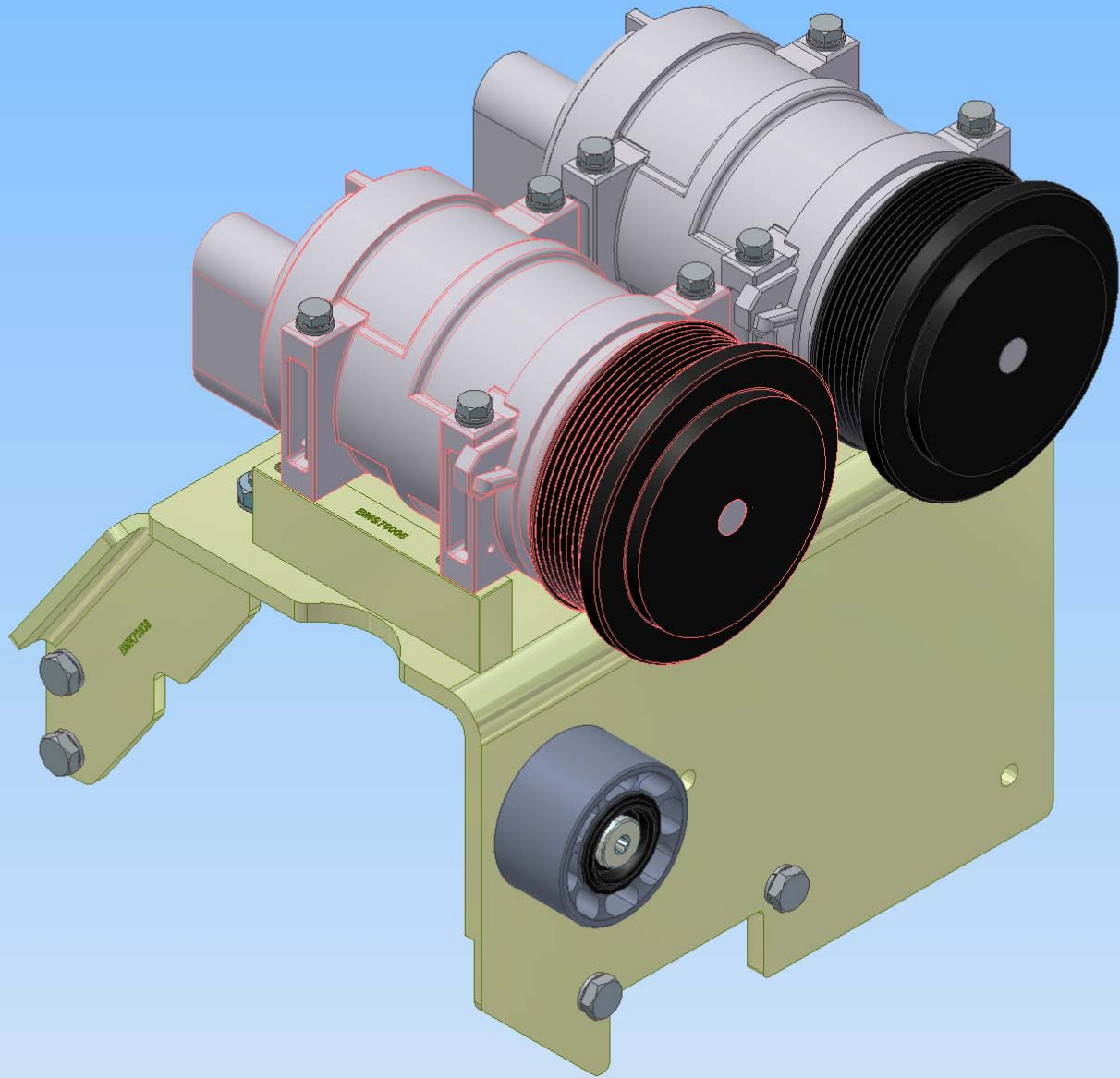

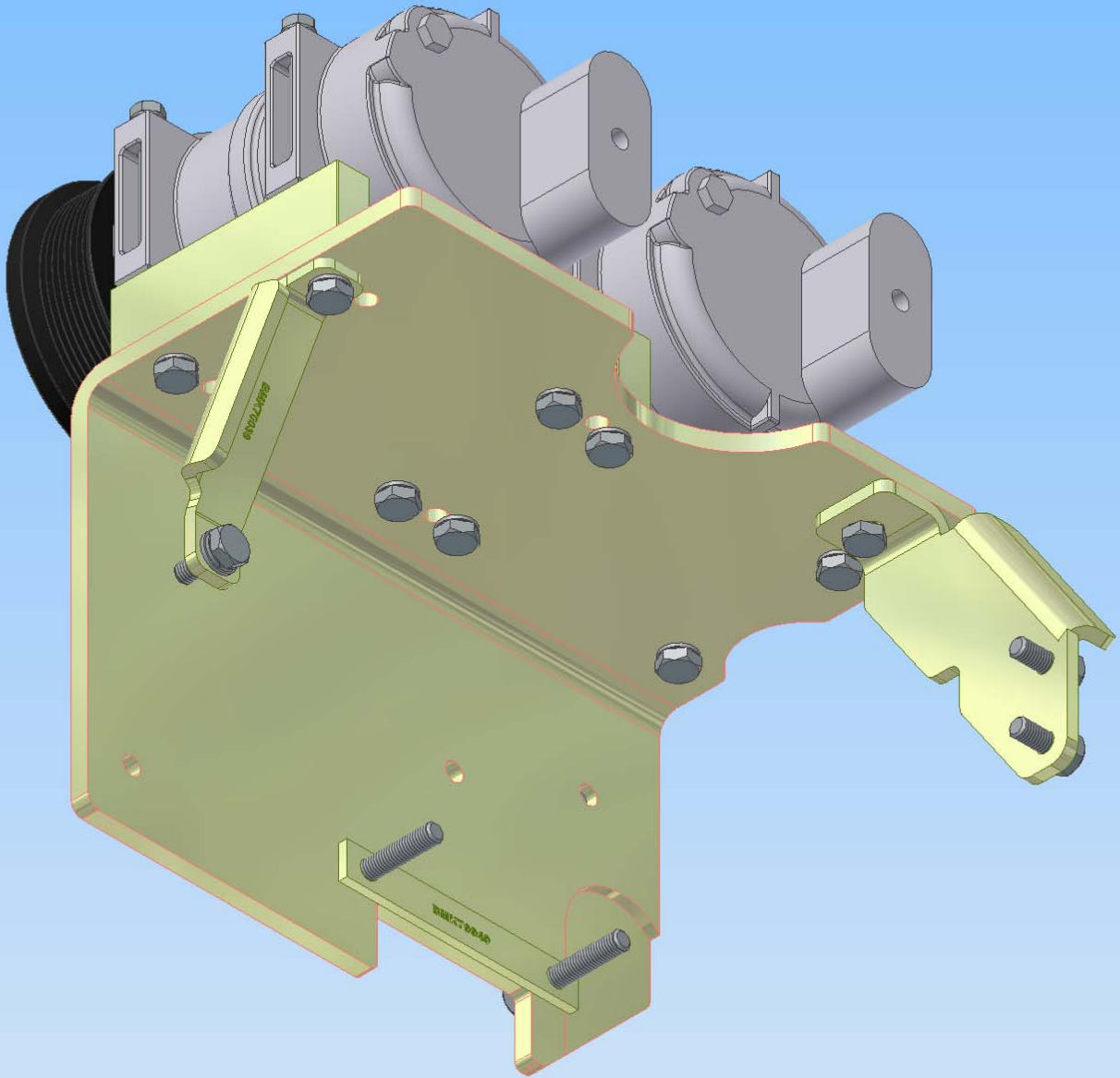

TransArctic A/C Compressor Mount Installation Disclaimer

Due to the many different situations, parameters and application criteria, which are beyond the compressor mount manufacturer's control, TransArctic does not warrant design, durability, or operational functionality of any compressor mount installed by another party.

The installer of any compressor mount purchased from TransArctic must undertake all responsibility of issues arising from that compressor bracket being installed on any vehicle. Mount functionality, operation and durability can all be compromised by an incompetent installation.

All compressor mounts should be installed by qualified and trained personnel using proper tools and equipment in safe working conditions following industry standard guidelines for motor vehicle service and repair.

With no implied guarantees it is the mount installer's strict responsibility to determine safety and functionality, of the compressor mount, at the time of installation.

Please contact TransArctic with any issue arising from installation so we may better improve the product. If you have any reservations about the compressor mount integrity contact TransArctic immediately at 1-877-COLD-AIR.