

Bill of Materials Listing

TransArctic Canada Inc.

5/20/2015
Page 1 of 1

Product Number	Description	Date	Weight	Uof M	Yield
Line Component Prod#	Description	Bin Unit	Qty		
KMC63470	Mt Kit, 6.7L ISB, BBCV, TM-55, P8, '07-10	03/29/11	45.05		0
10 BEL61562	Belt, 6gr, 1562mm (61.5") (5060615)	each	1		
20 BMC67063	Bkt, Alt, Bar, ISB, F400, BBCV, '10	each	1		
30 BMC67069	Bkt, Angle, Brace, Hanger, Hose, 2010	each	2		
40 BMC67071	Bkt, Main, 6.7L, ISB, TM-55, BBCV, '10	each	1		
50 BMC67072	Bkt, Adapt PL, ISB, TM-55/43, BBCV, '10-'13	each	1		
60 BMC67074	Bkt, Main, V Weldmt, TM-55/43/31, '10-'13	each	1		
70 BMC67075	Bkt, Shroud, Cover, 12ga, ISB, TM-55, '10	each	1		
75 BMC67076	Bkt, Support, Rad, ISB, TM-55, BBCV, '10	each	1		
80 BMC67107	Bkt, Spacer, Pl, TM-65/55, .06", ALUM	each	2		
90 BMZ00028	Bkt, Universal Hose & Cable	each	1		
95 BMZ00029	Bkt, Univer, Hose/Cable, MT, U/S Chassis	each	1		
100 CLP20001	Clamp, Gear, #20, 3/4-1 3/4 (19/44mm), S	each	2		
120 TEN60000	Tenr, HD Spring, BackSide, CW (89204)	each	1		
130 KBC63470	Bag Kit, Fasteners, KMC63470	each	1		

NOTES:

- 1) THE "TURBO TUBE" IS ROTATED "END TO END" WHEN RE-INSTALLING IT BACK ONTO THE BUS.
- 2) Belt runs in the "REAR 6 grooves" of the compressor pulley.
- 3) Use blue "Loctite" when installing the (2) Alternator bolts.

Bill of Materials Listing

TransArctic Canada Inc.

5/20/2015
Page 1 of 1

Product Number	Description	Date	Weight	Uof M	Yield
Line Component Prod#	Description	Bin Unit	Qty		
KBC63470	Bag Kit, Fasteners, KMC63470	04/08/11	2.69		0
10 BTC08030	Bolt, Hex, 8 x 1.25 x 30mm, 10.9, Plt,FT	each	2		
20 BTC10020	Bolt, Hex, 10 x 1.5 x 20mm, 10.9, Plt	each	1		
30 BTC10025	Bolt, Hex, 10 x 1.5 x 25mm, 10.9, Plt	each	5		
40 BTC10030	Bolt, Hex, 10 x 1.5 x 30mm, 10.9, Plt	each	1		
50 BTC10070	Bolt, Hex, 10 x 1.5 x 70mm, 10.9, Plt	each	4		
60 BTC10140	Bolt, Hex, 10 x 1.5 x 140mm, 10.9, Plt	each	2		
70 BTC12030	Bolt, Hex, 12 x 1.75 x 30mm, 10.9, Plt	each	2		
75 BTC12035	Bolt, Hex, 12 x 1.75 x 35mm, 10.9,Plt,FT	each	4		
80 BTC12090	Bolt, Hex, 12 x 1.75 x 90mm, 10.9, Plt	each	1		
90 CSF08031	Capscrew, FH, 8 x 1.25 x 30mm, 10.9,Plt	each	2		
100 CSF12036	Capscrew, FH, 12 x 1.75 x 35mm, 10.9,Plt	each	4		
110 NTA10000	Nut, Hex, 10 x 1.5, 8.8, Plt	each	1		
120 WFA08000	Washer, Flat, 8mm, 8.8, Plt	each	2		
130 WFA10000	Washer, Flat, 10mm, 8.8, Plt	each	11		
140 WFA12000	Washer, Flat, 12mm, 8.8, Plt	each	7		
150 WLA08000	Washer, Lock, 8mm, 8.8, Plt	each	2		
160 WLA10000	Washer, Lock, 10mm, 8.8, Plt	each	11		
170 WLA12000	Washer, Lock, 12mm, 8.8, Plt	each	7		

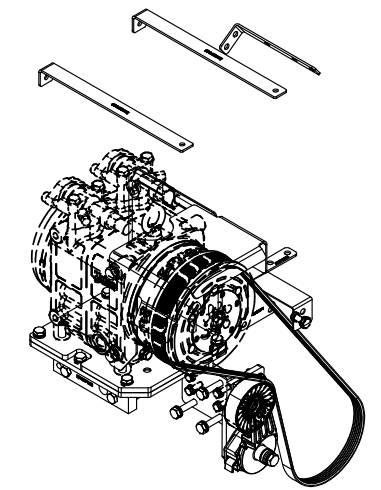
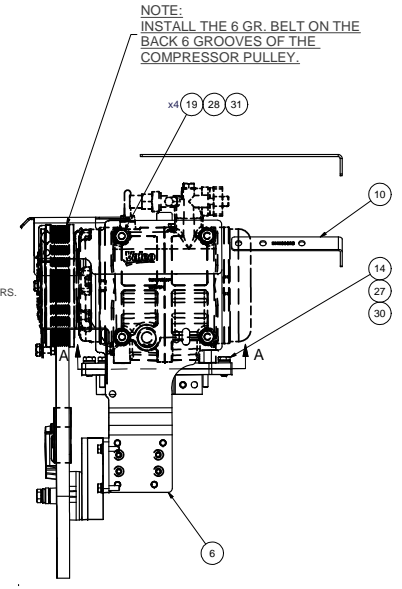
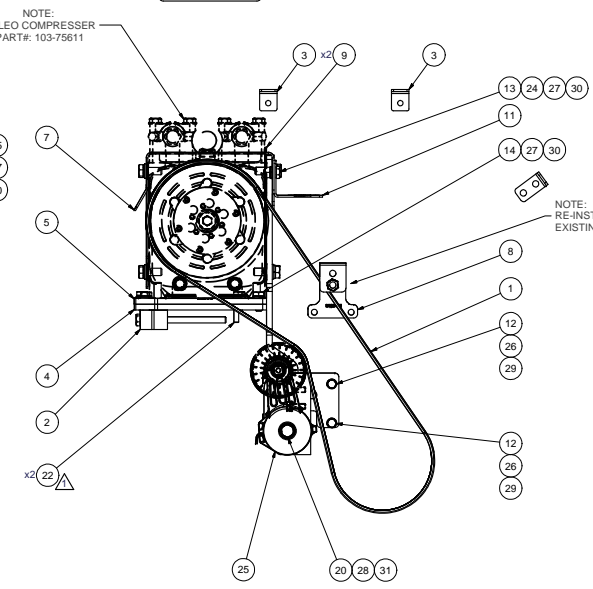
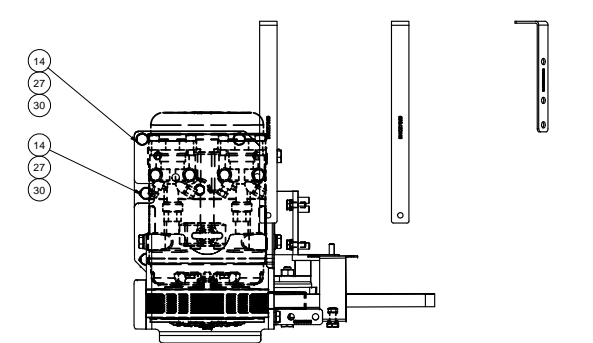

ISOMETRIC VIEW

NOTES:
 1) USE SERVICABLE THREADLOCKER ON ALL FASTENERS TO ENGINE COMPONENTS AND TORQUE ALL BOLTS TO S.A.E. SPECIFICATIONS.
 2) SEE "TRANSARGTIC A/C COMPRESSOR MOUNT INSTALLATION DISCLAIMER".

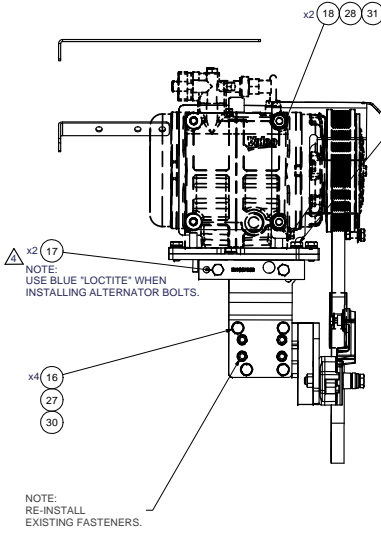

NOTE: RE-INSTALL EXISTING FASTENERS.

NOTE: RE-INSTALL EXISTING FASTENERS.

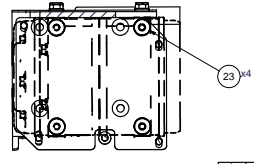

SECTION A-A

ITEM	QTY	U/M	PART NUMBER	DESCRIPTION
31	7	EACH	WL12000	WASHER, LOCK, 12mm, 8.8, PLT
30	11	EACH	WL10000	WASHER, LOCK, 10mm, 8.8, PLT
29	2	EACH	WLA08000	WASHER, LOCK, 8mm, 8.8, PLT
28	7	EACH	WFA12000	WASHER, FLAT, 12mm, 8.8, PLT
27	11	EACH	WFA10000	WASHER, FLAT, 10mm, 8.8, PLT
26	2	EACH	WFA08000	WASHER, FLAT, 8mm, 8.8, PLT
25	1	EACH	TEN60000	TENR, HD SPRING, BACKSIDE, CW (89204)
24	1	EACH	NTA10000	NUT, HEX, 10 x 1.5, 8.8, PLT
23	4	EACH	CSF12036	CAPSCREW, FH, 12 x 1.75 x 35mm, 10.9, PLT
22	2	EACH	CSF08031	CAPSCREW, FH, 8 x 1.25 x 30mm, 10.9, PLT
21	2	EACH	CLP20001	CLAMP, GEAR, #20, 3/4-1 3/4 (19/44mm)
20	1	EACH	BTC12090	BOLT, HEX, 12 x 1.75 x 90mm, 10.9, PLT
19	4	EACH	BTC12025	BOLT, HEX, 12 x 1.75 x 25mm, 10.9, PLT
18	2	EACH	BTC12030	BOLT, HEX, 12 x 1.75 x 30mm, 10.9, PLT
17	2	EACH	BTC10140	BOLT, HEX, 10 x 1.5 x 140mm, 10.9, PLT
16	4	EACH	BTC10070	BOLT, HEX, 10 x 1.5 x 70mm, 10.9, PLT
15	1	EACH	BTC10030	BOLT, HEX, 10 x 1.5 x 30mm, 10.9, PLT
14	5	EACH	BTC10025	BOLT, HEX, 10 x 1.5 x 25mm, 10.9, PLT
13	1	EACH	BTC10020	BOLT, HEX, 10 x 1.5 x 20mm, 10.9, PLT
12	2	EACH	BTC08030	BOLT, HEX, 8 x 1.25 x 30mm, 10.9, PLT
11	1	EACH	BMZ00029	BKT, UNIVER, HOSE/CABLE, MT, US3 CHASSIS
10	1	EACH	BMZ00028	BKT, UNIVERSAL HOSE & CABLE CLAMP
9	2	EACH	BMC67107	BKT, SPACER PL, TM-45/55, .06", ALUM
8	1	EACH	BMC67076	BKT, SUPPORT, RAD, ISB, TM-55, BBCV, '10
7	1	EACH	BMC67075	BKT, SHROUD, COVER, 12ga, ISB, TM-55, '10
6	1	EACH	BMC67074	BKT, MAIN, V Weldmt, TM-55/43/31, '10-'13
5	1	EACH	BMC67072	BKT, ADAPT PL, ISB, TM-55/43, BBCV, '10-'13
4	1	EACH	BMC67071	BKT, MAIN, 6.7L, ISB, F400, BBCV, '10
3	2	EACH	BMC67069	BKT, ANGLE, BRACE, HANGER, HOSE, 2010
2	1	EACH	BMC67063	BKT, ALT, BAR, ISB, F400, BBCV, '10
1	1	EACH	BEL1562	BELT, 6Gr, 1562mm (61.5") (5060615)

BILL OF MATERIALS

REV	DESCRIPTION	DATE	BY
4	REV'D WSHRS AND ADDED NOTE	05/2015	VAL
3	ISS RELEASED CORRO REV TO BEST PRACT	07/2014	VAL
2	ISS RELEASED CORRO TITLE REV'D	12/18/12	VAL
1	MODIFIED BMC67071/2/3/4/5	7/4/2011	JRR
0	RELEASED TO PRODUCTION	4/8/2011	JRR

TRANSARGTIC INC.

TITLE: MT KIT, 6.7L ISB, BBCV, TM-55, '10

DATE: 04/08/11

BY: James Stewart

APPROVED: Dale Mason

DATE: 04/08/11

BY: James Stewart

SIZE: D

DWG NO: KMC63470

REV: 4

SCALE: 1:4

SHEET 1 OF 1

UNSPECIFIED TOLERANCES:

ONE DECIMAL PLACE (X)	0.1
TWO DECIMAL PLACE (X)	0.05
THREE DECIMAL PLACE (X)	0.025
FRACTIONAL (X) SIZE	ANGULAR ± .01

THIRD ANGLE PROJECTION

DRAWING UNIT OF MEASURE: MM [INCH]

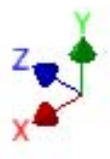
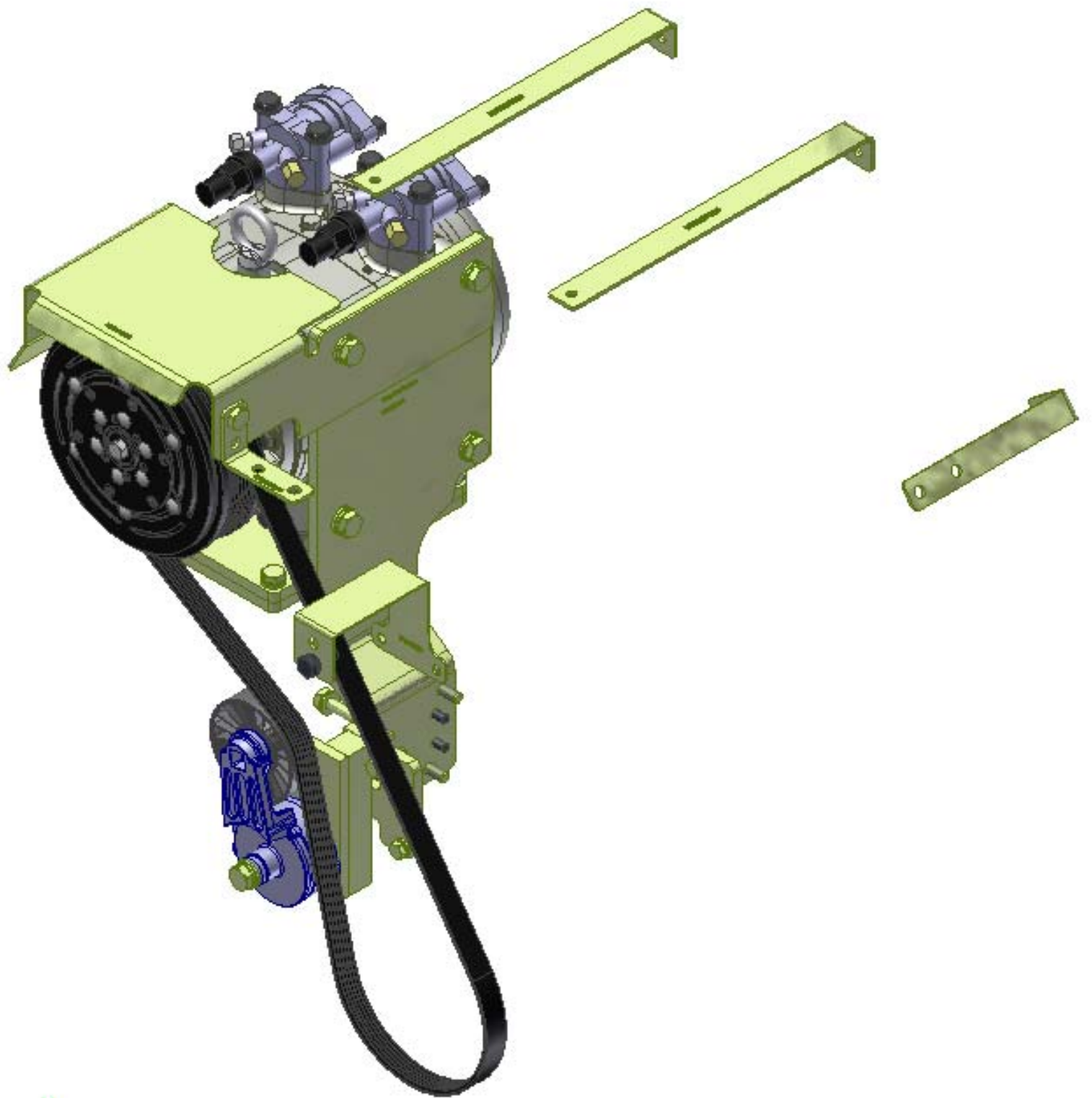

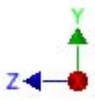
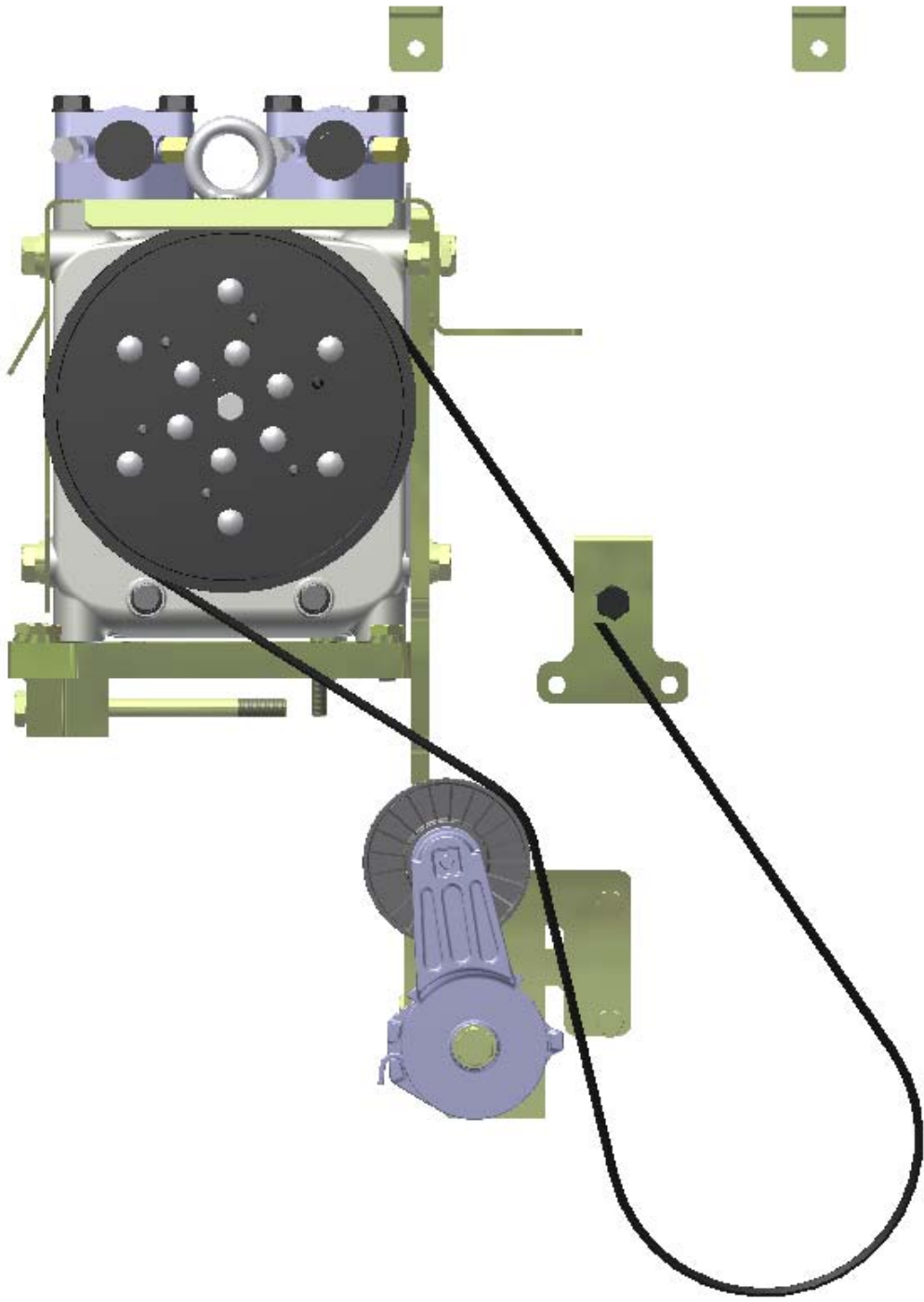

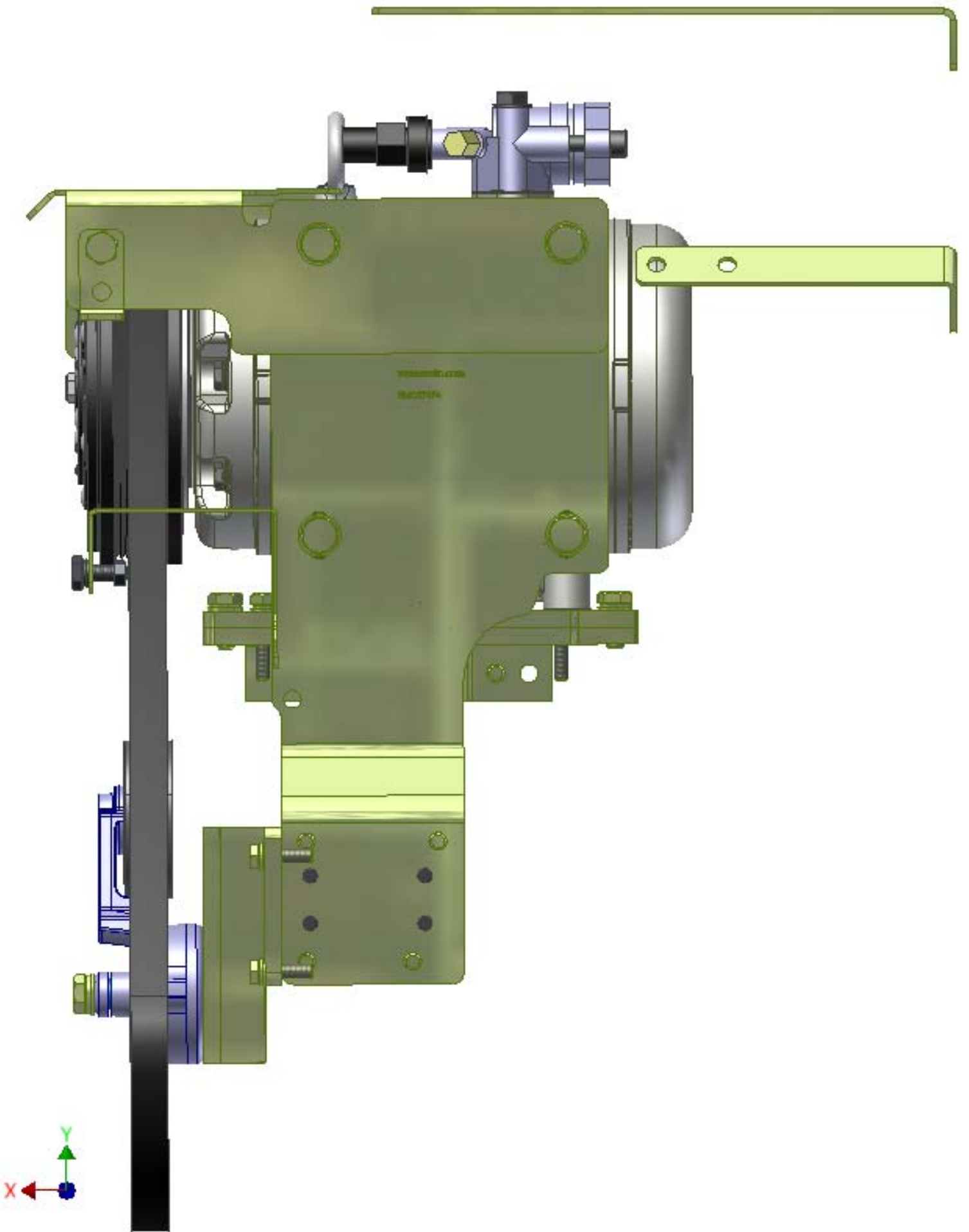

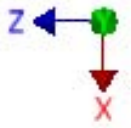
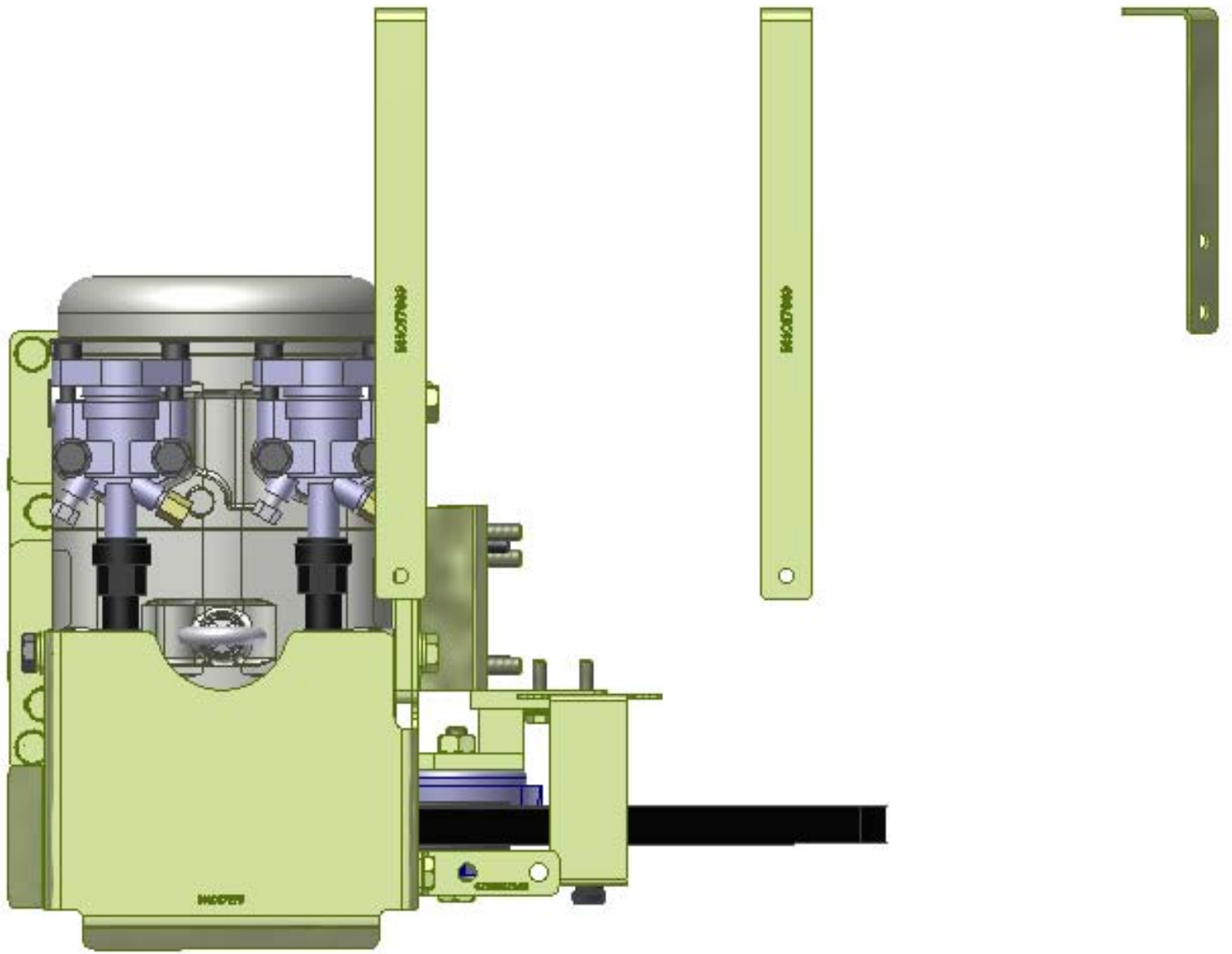

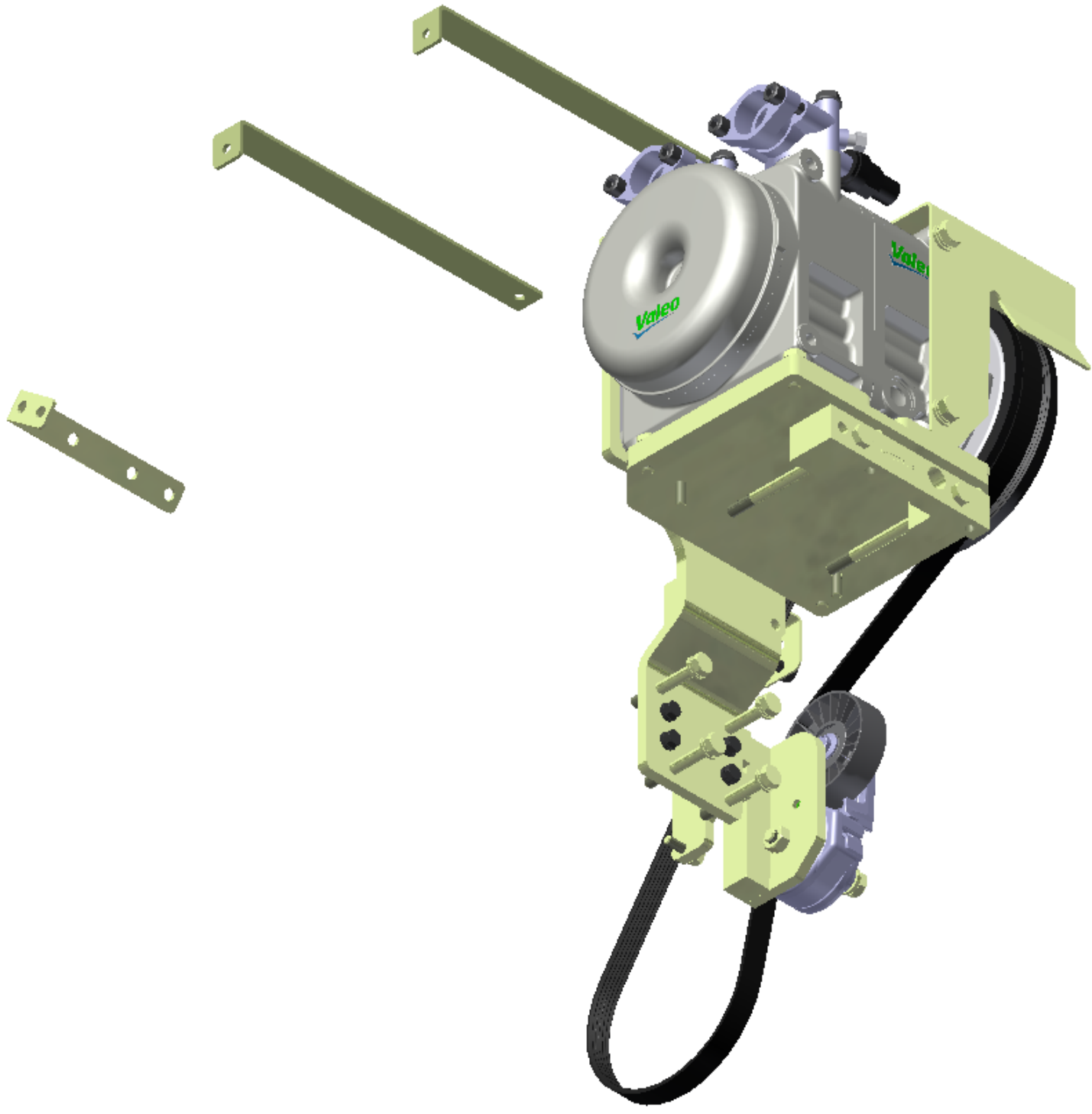

**NOTE: THE BITZER F400
COMPRESSOR IS SHOWN IN
LIEU OF THE VALEO TM-55.**

2x BMC67069

BMZ00028

BMZ00029

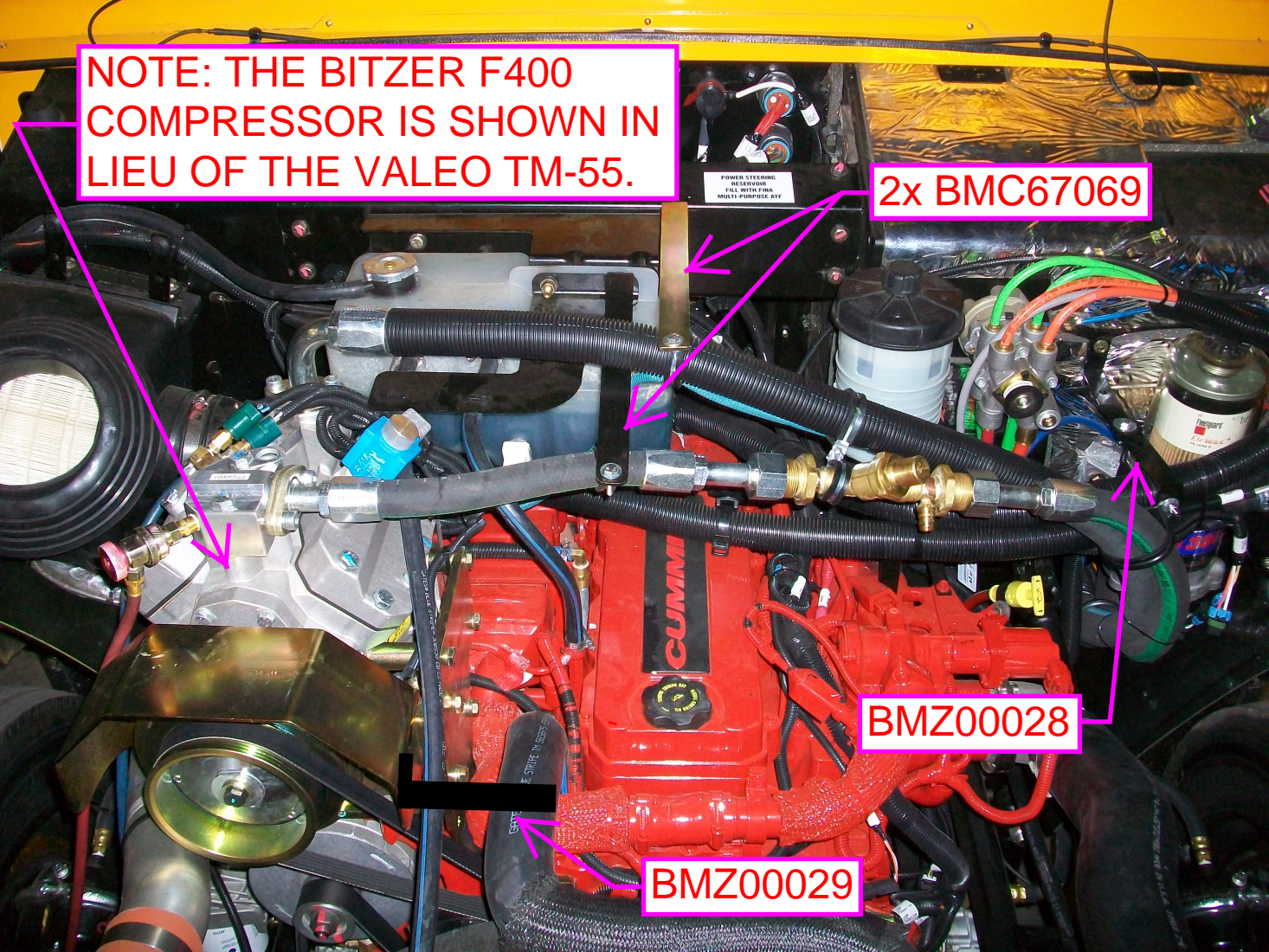

TransArctic A/C Compressor Mount Installation Disclaimer

All compressor mounts should be installed by qualified and trained personnel using proper tools and equipment in safe working conditions following industry standard guidelines for motor vehicle service and repair.

The installer of any compressor mount purchased from TransArctic must undertake all responsibility of issues arising from that compressor bracket being installed on any vehicle. As well as insure that a **proper and sufficient ground** is established between the compressors' clutches and the vehicle's engine. Mount functionality, operation and durability can all be compromised by an incompetent installation.

Due to the many different situations, parameters and application criteria, which are beyond the compressor mount manufacturer's control, TransArctic does not warrant design, durability, or operational functionality of any compressor mount improperly installed by another party.

With no implied guarantees it is the mount installer's strict responsibility to determine safety and functionality, of the compressor mount, at the time of installation.

Please contact TransArctic with any issue arising from installation so we may better improve the product. If you have any reservations about the compressor mount integrity contact TransArctic immediately at 1-877-COLD-AIR.

Mark OEM tensioner location

Install Kit

Check for Interferences

Check to ensure that the proper OEM tensioner orientation is maintained

Run engine with A/C system engaged for at least 10 minutes to run in belt

Check OEM tensioner orientation and adjust as required

Responsabilidad limitada de TransArctic en la instalación del soporte del compresor

Todos los soportes de los compresores deben ser instalados por personas calificadas y entrenadas, usando para ello los equipos y herramientas necesarios para esta labor en buenas condiciones y según las normas y guías para el servicio y/o reparación de motores de vehículos.

El instalador de los soportes comprados en TransArctic asume toda la responsabilidad de cualquier problema que surga en el soporte del compresor al vehículo; de igual manera es responsable que el cable a tierra sea conectado entre el embrague del compresor y el motor del vehículo.

Se advierte que el buen funcionamiento y la durabilidad del soporte pueden ser comprometidos por defectos en su instalación.

Debido a las diversas situaciones que se puedan presentar fuera del control del fabricante, TransArctic no garantiza el diseño, la durabilidad o el correcto funcionamiento de cualquier equipo inapropiadamente instalado por terceros.

Esta sobreentendido que el Instalador del montaje del compresor es estrictamente responsable de la seguridad y funcionamiento del equipo en el momento de la instalación.

Si tuviera algún problema o duda acerca de la instalación del soporte del compresor pongase en contacto inmediatamente con TransArctic al teléfono 1-877-COLD-AIR de modo que podamos mejorar nuestro producto.

Note la ubicación del medidor de tensión OEM

Instale el equipo

Controlar si hay interferencias.

Asegurese que el medidor de tensión mantenga la orientación justa.

Encienda el motor por lo menos 10 minutos con el sistema A/C enganchado para que la correa corra

Controle la orientación justa del medidor de tensión y ajuste a las condiciones requeridas del fabricante