

Bill of Materials Listing

TransArctic Canada Inc.

11/10/2020
Page 1 of 1

Product Number	Date	Description	Uof M	Weight	Yield	
Line	Qty	Component Prod#	Rev#	Bin	Unit	
KMC46697	4/25/2017	0 Mt Kit, ISL-G, HDX, TM-55/65, ALT, '20			1130.49	0
5	1	PAC39131			each	
10	1	BEL32286			each	
20	1	BMC90017		2 Bkt, Found'n, TH HDX, 4xFC/ 4K40, '16	each	
30	1	BMC90022		0 Bkt, Main, Idler, Weldm't, ISL, HDX, '16	each	
35	1	BMZ00074		0 Bkt, Adapter, P/S, 4xFC To TM-55/65	each	
40	1	BMZ01059		0 Bkt, Slide, Block, TH, HDX, '12	each	
45	1	KAC65501		1 Kit, Alternator, TM-65, Curb Side, '13	each	
50	1	KBB00002		0 Kit, PS, Platform, Transit, ADM, '20	each	
60	1	KPC90009		0 Kit, Pulley, ISL-G, 8.9L, 2B/X,'17	each	
70	1	PUA05001		0 Pulley, Assy, Idler, B/S, 5", Stl, Plt	each	
80	1	PUA05012		0 Pulley, Assy, Idler,B/BX gr,5", STL,Plt	each	
90	1	SCD16012		1 Spacer, Col, Drl,16 mm x 34.9o x 12.3i	each	
100	1	SCD21912		0 Spacer, Col, Drl,21.9mm x 25.4o x 12.3i	each	
110	2	SLV17012		0 Sleeve, Pulley, 16.9o x 22.23mm x 12.32i	each	
120	1	KBC96597		0 Bag Kit, Fasteners, KMC96597 & KMC96697	each	

Bill of Materials Listing

TransArctic Canada Inc.

6/2/2020
Page 1 of 1

Product Number		Description	Rev#	Date	Weight	Uof M	Yield
Line	Component Prod#	Description	Bin	Unit	Qty		
KBC96597		Bag Kit, Fasteners, KMC96597 & KMC96697	0	7/14/2016	2.96		0
10	BTC10045	Bolt, Hex, 10 x 1.5 x 45mm, 10.9, Plt,FT		each	3		
20	BTC12080	Bolt, Hex, 12 x 1.75 x 80mm, 10.9,Plt,FT		each	2		
30	BTQ06175	Bolt, Hex, 3/8-16unc, 1.75", 8, Plt		each	8		
40	BTQ08200	Bolt, Hex, 1/2-13unc, 2.0", 8, Plt		each	3		
45	CSF08150	Capscrew, FH, 1/2-13 x 1.50", Alloy, Plt		each	1		
47	CSF12036	Capscrew, FH, 12 x 1.75 x 35mm, 10.9,Plt		each	4		
50	NTA10000	Nut, Hex, 10 x 1.5, 8.8, Plt		each	3		
60	NTA12000	Nut, Hex, 12 x 1.75, 8.8, Plt		each	2		
70	NTQ06000	Nut, Hex, 3/8-16unc, 8, Plt		each	8		
80	NTQ08000	Nut, Hex, 1/2-13unc, 8, Plt		each	4		
90	WFA10002	Washer, Flat, 10mm, Hvy, 8.8, Plt		each	6		
100	WFA12002	Washer, Flat, 12mm, Hvy, 8.8, Plt		each	2		
110	WFQ08000	Washer, Flat, 1/2", 8, Plt		each	7		
120	WFS06002	Washer, Flat, 3/8", L9, Plt		each	16		
130	WLA10000	Washer, Lock, 10mm, 8.8, Plt		each	3		
140	WLA12000	Washer, Lock, 12mm, 8.8, Plt		each	2		
150	WLQ06000	Washer, Lock, 3/8", 8, Plt		each	8		
160	WLQ08000	Washer, Lock, 1/2", 8, Plt		each	4		

Bill of Materials Listing

TransArctic Canada Inc.

2/4/2022
Page 1 of 1

Product Number	Date	Description		Uof M	Weight	Yield
Line	Qty	Component Prod#	Rev#	Description	Bin	Unit
KAC65501	08/10/16	3 Kit, Alternator, TM-65, Curb Side, '13				45.31
10	2	BEL11040		Belt, A gr, 1040mm (41")		each
20	1	BMC90020	A	Bkt, Alt, Weldm't, Curb Side, TM65/55, '16		each
30	2	BMT10011	0	Bkt, Tenr, Block, Offset, 3mm		each
40	1	PUL03321	1	Pulley, ALT, Idler, 3.25"d, 2A		each
45	1	KBA84064	0	Bag Kit, ALT Shim, KC84064, KAC65501/02		each
47	1	SCD05513	0	Spacer, Col, Drl, 5.51mm x 25.4o x12.7i	Alley	each
50	1	TRD08080		Threaded, Rod, 1/2-13unc x 8", 5, Plt		each
60	1	KBA65501	0	Bag Kit, Fasteners, KAC65501		each

NOTE:

1) Use KBA84064 "Shim bag kit", as required, to align the Alternator correctly.

Bill of Materials Listing

TransArctic Canada Inc.

11/6/2020
Page 1 of 1

Product Number	Date	Description	Uof M	Weight	Yield			
Line	Qty	Component Prod#	Rev#	Description	Bin	Unit	Weight	Yield
KBA65501	8/10/2016	0	0	Bag Kit, Fasteners, KAC65501			1.45	0
10	4	BTC12035		Bolt, Hex, 12 x 1.75 x 35mm, 10.9,Plt,FT		each		
20	1	BTQ08125		Bolt, Hex, 1/2-13unc, 1.25", 8, Plt		each		
30	1	BTQ08150		Bolt, Hex, 1/2-13unc, 1.5", 8, Plt		each		
40	1	BTQ08653		Bolt, Hex, 1/2-13unc, 6.5", 8, Plt		each		
50	6	NTQ08000		Nut, Hex, 1/2-13unc, 8, Plt		each		
60	4	WFA12000		Washer, Flat, 12mm, 8.8, Plt		each		
70	3	WFQ08000		Washer, Flat, 1/2", 8, Plt		each		
80	4	WLA12000		Washer, Lock, 12mm, 8.8, Plt		each		
90	4	WLQ08000		Washer, Lock, 1/2", 8, Plt		each		

Bill of Materials Listing

TransArctic Canada Inc.

2/4/2022
Page 1 of 1

Product Number	Date	Description			Uof M	Weight	Yield		
Line	Qty	Component	Prod#	Rev#	Description	Bin	Unit		
KBA84064	10/19/21	0			Bag Kit, ALT Shim, KC84064, KAC65501/02			0.09	0
10	1	SCD03613		0	Spacer, Col, Drl, 3.56mm x 25.4o x12.7i	Alley	each		
20	2	WFA14000			Washer, Flat, 14mm, 8.8, Plt		each		
30	2	WFQ08000			Washer, Flat, 1/2", 8, Plt		each		

NOTE:

1) Use (1) SCD03613, (2) WFA14000, (2) WFQ08000, in any arrg'mt/qtys as required to align the Alternator correctly.

Bill of Materials Listing

TransArctic Canada Inc.

6/3/2020
Page 1 of 1

Product Number		Description	Rev#	Date	Weight	Uof M	Yield
Line	Component Prod#	Description	Bin	Unit	Qty		
KBB00002		Kit, PS, Platform, Transit, ADM, '20	0	6/20/2012	75.91		0
10	BMZ01034	Bkt, Spring, Support Arm, ADM, '12		each	1		
20	BMZ01035	Bkt, Main, Pivot, Ass'y, ADM Transit, '12		each	1		
30	BMZ01037	Bkt, Fork, Knuckle-Joint, Adm, '12		each	1		
40	BMZ01038	Bkt, Main, Base Pl, ADM, '12		each	1		
50	BMZ01040	Bkt, Ass'y, THRD Rod, Isolator, ADM, '12		each	1		
60	BMZ01041	Shaft Key, 5/16" SQ x .540" Long		each	2		
70	BMZ01042	Vibration Isolator, Bar, 9.63 x 2 x 1.50		each	2		
80	BMZ01044	Bkt, Cradle, Pivot, Adm Transit, '12		each	1		
90	BMZ01047	Bkt, Bar, Slide Nut, ADJ, Trans ADM, '12		each	2		
110	PIS01010	Shaft, Stl, Grease, ADM Transit, '12		each	1		
120	SPR00002	Spring, Comp, R/H, 110 x 50 x 8.4, Red		each	1		
130	WFS16001	Washer, Flat, Dbl Step, 17mm, 50mm, Plt		each	1		
140	WFS27001	Washer, Flat, Dbl Step, 27mm, 63.5, Plt		each	1		
150	KBB00025	Bag Kit, Fasteners, KBB00001		each	1		
160	KBB00026	Bag Kit, Fasteners, Assembly, KBB00001		each	1		

NOTE:

Use Blue "Loctite" on the (4) fasteners to fasten BMZ01034 in place.
 1/2 -13 UNC grd. 8 bolts, c/w
 L'whrs torque... used on the PIS01010 Shaft = 45 FT*LBS.
 (/VTS@ JAN-25-2019)

Bill of Materials Listing

TransArctic Canada Inc.

6/3/2020
Page 1 of 1

Product Number	Description	Rev#	Date	Weight	Uof M	Yield
Line	Component Prod#	Bin	Unit	Qty		
KBB00025	Bag Kit, Fasteners, KBB00001/2	5	8/1/2012	1.61		0
10	BTQ08126		each	6		
20	BTQ08150		each	1		
30	BTQ10351		each	1		
50	NTQ08000		each	1		
60	NTQ10000		each	2		
65	NTQ10001		each	1		
100	WFQ08000		each	8		
110	WFQ10000		each	2		
120	WLQ08000		each	7		
130	WLQ10000		each	2		

Bill of Materials Listing

TransArctic Canada Inc.

6/3/2020
Page 1 of 1

Product Number		Description	Rev#	Date	Weight	Uof M	Yield
Line	Component Prod#	Description	Bin	Unit	Qty		
KBB00026		Bag Kit, Fasteners, Assembly, KBB00001/2	4	8/1/2012	2.48		0
5	BTQ08101	Bolt, Hex, 1/2-20unf, 1.00", 8, Plt		each	6		
15	BTQ08100	Bolt, Hex, 1/2-13unc, 1.00", 8, Plt		each	1		
20	BTQ08150	Bolt, Hex, 1/2-13unc, 1.5", 8, Plt		each	8		
70	WFS08001	Washer, Flat, 1/2", 8, USS, Plt		each	2		
100	WFQ08000	Washer, Flat, 1/2", 8, Plt		each	6		
120	WLQ08000	Washer, Lock, 1/2", 8, Plt		each	16		
130	NTQ08000	Nut, Hex, 1/2-13unc, 8, Plt		each	4		
140	BTM08100	Bolt, 1/2-13 x 1.0" w/ Grease Nipple FTG		each	1		

Bill of Materials Listing

TransArctic Canada Inc.

11/10/2020

Page 1 of 1

Product Number	Date	Description		Uof M	Weight	Yield		
Line	Qty	Component Prod#	Rev#	Description	Bin	Unit	Yield	
KPC90009	10/15/2013		0	Kit, Pulley, ISL-G, 8.9L, 2B/X,'17			16.40	0
10	1	PUL90009		2 Pulley, Crank, ISL-G, 9.0L, 2B/X, 8", '17		each		
20	4	BTC12080		Bolt, Hex, 12 x 1.75 x 80mm, 10.9,Plt,FT		each		
30	4	WFS12002		0 Washer, Flat, Hdn, 12mm, Stl, BLK		each		

NOTE:
COMPRESSOR & ALTERNATOR REMOVED FOR CLARITY.

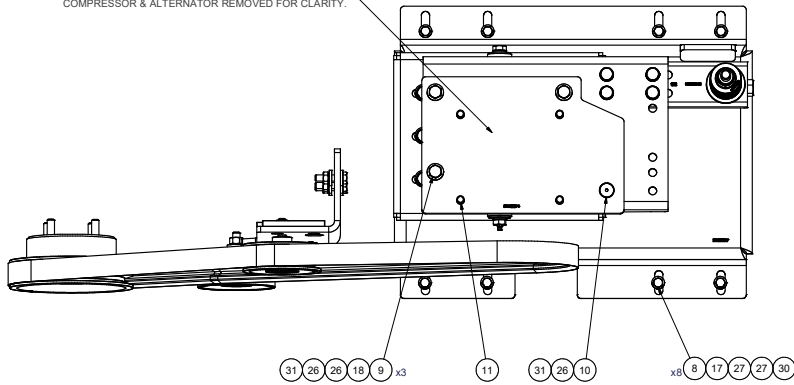

NOTE:
SHOWING TRANSARCTIC
COMPRESSOR PART#
CMV33644 (TM-55)/
CMV38844 (TM-65)
AS REFERENCE.

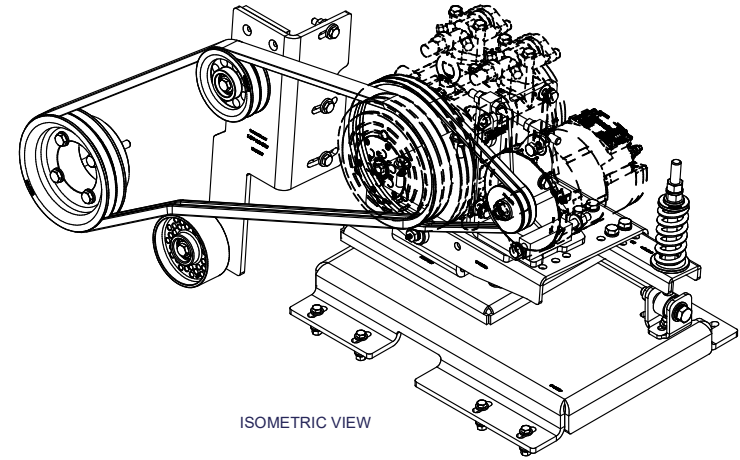
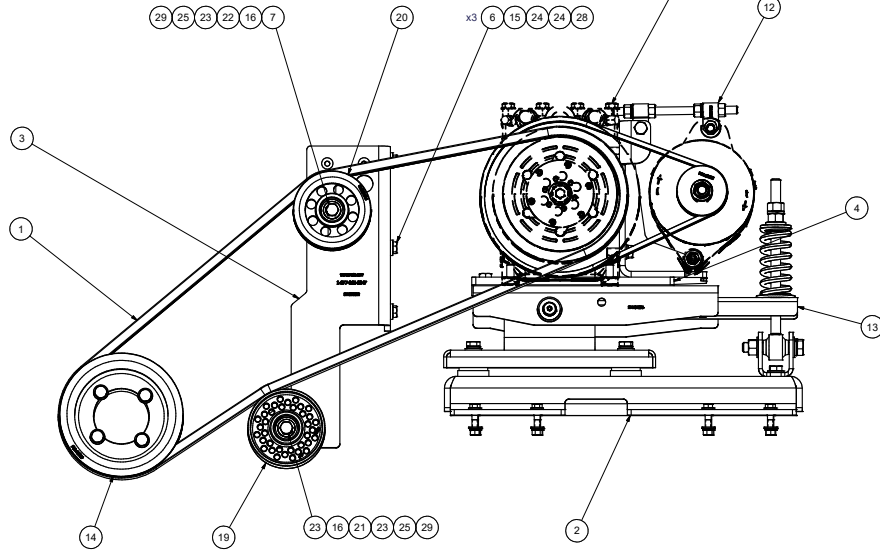

ISOMETRIC VIEW

NOTES:

1) USE SERVICABLE THREADLOCKER ON ALL FASTENERS TO ENGINE COMPONENTS AND TORQUE ALL BOLTS TO S.A.E. SPECIFICATIONS.

2) SEE "TRANSARCTIC A/C COMPRESSOR MOUNT INSTALLATION DISCLAIMER".

ITEM	QTY	U/M	PART NUMBER	DESCRIPTION
31	4	EACH	WLQ08000	WASHER, LOCK, 1/2", 8, PLT
30	8	EACH	WLQ06000	WASHER, LOCK, 3/8", 8, PLT
29	2	EACH	WLA12000	WASHER, LOCK, 12mm, 8.8, PLT
28	3	EACH	WLA10000	WASHER, LOCK, 10mm, 8.8, PLT
27	16	EACH	WFS06002	WASHER, FLAT, 3/8", 19, PLT
26	7	EACH	WFO08000	WASHER, FLAT, 1/2", 8, PLT
25	2	EACH	WFA12002	WASHER, FLAT, 12mm, HVY, 8.8, PLT
24	6	EACH	WFA10002	WASHER, FLAT, 10mm, HVY, 8.8, PLT
23	2	EACH	SLV17012	SLEEVE, PULLEY, 16.90 x 22.23 mm x12.19!
22	1	EACH	SCD21912	SPACER, COL, DRL, 21.9mm x 31.80 x12.0!
21	1	EACH	SCD16012	SPACER, COL, DRL, 16 mm x 31.80 x12.0!
20	1	EACH	PUA05012	PULLEY, ASSY, IDLER, B/BX gr, 5" STL, PLT
19	1	EACH	PUA05001	PULLEY, ASSY, IDLER, B/S, 5", STL, PLT
18	4	EACH	NTQ08000	NUT, HEX, 1/2-13UNC, 8, PLT
17	8	EACH	NTQ06000	NUT, HEX, 3/8-16UNC, 8, PLT
16	2	EACH	NTA12000	NUT, HEX, 12 x 1.75, 8.8, PLT
15	3	EACH	NTA10000	NUT, HEX, 10 x 1.5, 8.8, PLT
14	1	EACH	KPC90009	KIT, PULLEY, ISL-G, 8.9L, 2B/X, '17
13	1	EACH	KBB00002	MT KIT, PS, PLATFORM, TRANSIT, ADM, '20
12	1	EACH	KAC65501	KIT, ALTERNATOR, TM-65, CURB SIDE, '13
11	4	EACH	CSF12036	CAPSCREW, FH, 12 x 1.75 x 35mm, 10.9, PLT
10	1	EACH	CSF08150	CAPSCREW, FH, 1/2-13 x 1.5", ALLOY, PLT
9	3	EACH	BTQ06200	BOLT, HEX, 1/2-13UNC x 2.00, 8, PLT
8	8	EACH	BTQ06175	BOLT, HEX, 3/8-16UNC, 1.75", 8, PLT
7	2	EACH	BTCL2080	BOLT, HEX, 12 x 1.75 x 80mm, 10.9, PLT, FT
6	3	EACH	BTCL0045	BOLT, HEX, 10 x 1.5 x 45mm, 10.9, PLT
5	1	EACH	BMZ01059	BKT, SLIDE, BLOCK, TH, HDX, '13
4	1	EACH	BMZ00074	BKT, PL, TM-55/65, HDX, INTERFACE, '50"
3	1	EACH	BMC90022	BKT, MAIN, IDLER, WELDMT, ISL, HDX, '16
2	1	EACH	BMC90017	BKT, FOUNDN, HDX, 4XFC, '16
1	1	EACH	BEL3228	BELT, BANDED B GR, 2286mm (90")

DRAWN		11/10/2020		BILL OF MATERIALS	
jrodriguez		11/10/2020		TRANSARCTIC INC.	
CHECKED					
Vni Jakowlew		11/10/2020		TITLE	
James Stewart		11/10/2020		MT KIT, ISL-G, HDX, TM-55/65, ALT, '20	
James Stewart		11/10/2020		APPROVED	
Dale Mason		11/10/2020		APPROVED	
UNSPECIFIED TOLERANCES:		ALL DIMS		DWG NO	
ONE DECIMAL PLACE (X1)		FRACTIONAL		D	
TWO DECIMAL PLACE (X2)		THIRD ANGLE PROJECTION		KMC46697	
THREE DECIMAL PLACE (X3)		DRAWING UNIT OF MEASURE		SCALE	
FRACTIONAL (X1/16)		MM (INCH)		1:4	
				SHEET 1 OF 1	

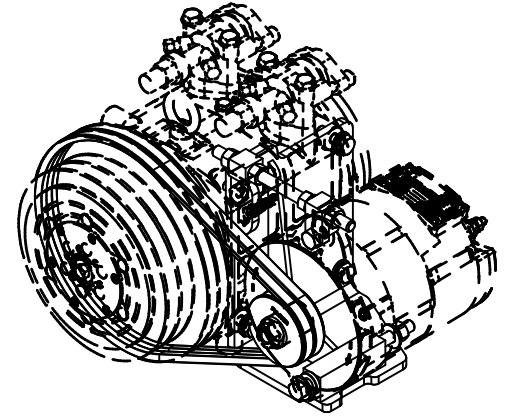
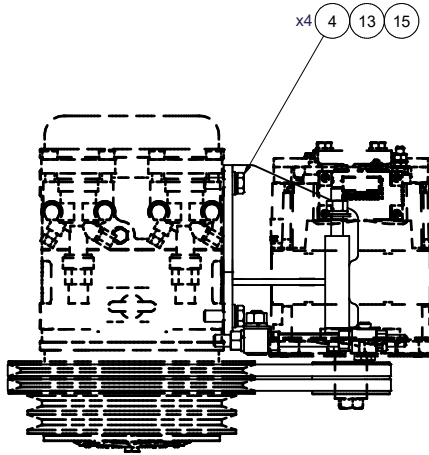

ISOMETRIC VIEW

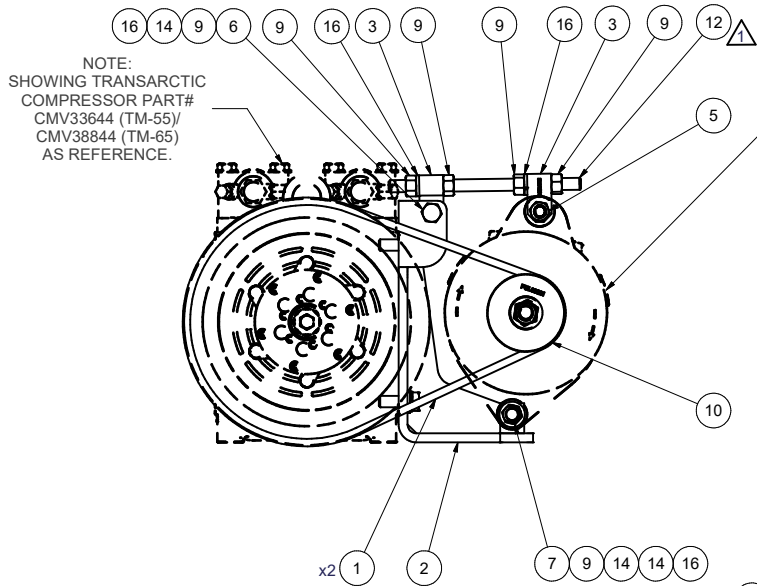

NOTE:
SHOWING TRANSARCTIC
COMPRESSOR PART#
CMV33644 (TM-55/
CMV38844 (TM-65)
AS REFERENCE.

NOTE:
SHOWING ALTERNATOR
AS REFERENCE

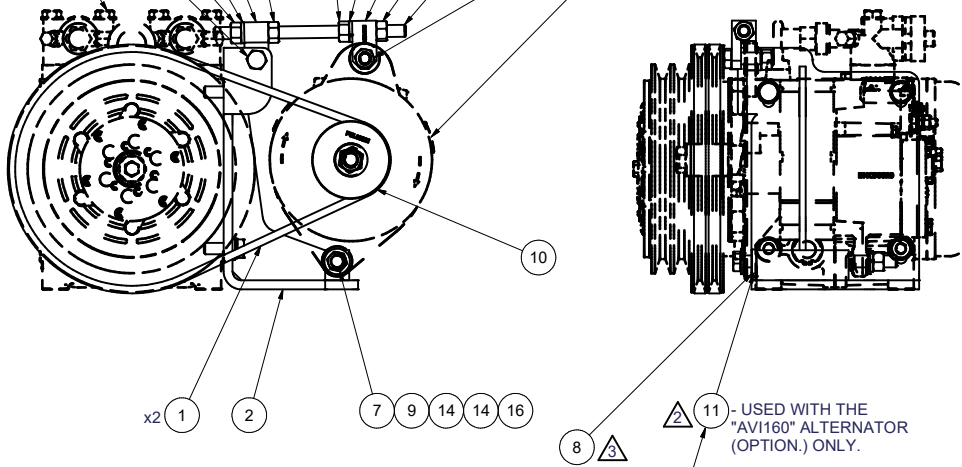

USE KBA84064 SHIM KIT AS REQUIRED
TO ALIGN ALTERNATOR PULLEY TO
COMPRESSOR PULLEY "A" GROOVES.

11 - USED WITH THE
"AVI160" ALTERNATOR
(OPTION.) ONLY.

NOTES:

- 1) USE SERVICABLE THREADLOCKER ON ALL FASTENERS TO ENGINE COMPONENTS AND TORQUE **ALL** BOLTS TO S.A.E. SPECIFICATIONS.
- 2) SEE "TRANSARCTIC A/C COMPRESSOR MOUNT INSTALLATION DISCLAIMER".
- 3) WEIGHT: 18.11 LB

16	4	EACH	WLQ08000	WASHER, LOCK, 1/2", 8, PLT
15	4	EACH	WLA12000	WASHER, LOCK, 12mm, 8.8, PLT
14	3	EACH	WFO08000	WASHER, FLAT, 1/2", 8, PLT
13	4	EACH	WFA12000	WASHER, FLAT, 12mm, 8.8, PLT
12	1	EACH	TRD08080	THREADED, ROD, 1/2-13UNC x 8", 5 PLT
11	1	EACH	SCD05513	SPACER, COL, DRL, 5.51mm x 25.4o x 12.7i
10	1	EACH	PUL03321	PULLEY, ALT, IDLER, 3.25"o, 2A
9	6	EACH	NTQ08000	NUT, HEX, 1/2-13UNC, 8, PLT
8	1	EACH	KBA84064	BAG KIT, ALT SHIM, KC84064, KAC65501/02
7	1	EACH	BTQ08653	BOLT, HEX, 1/2-13UNC x 6.50, 8, PLT
6	1	EACH	BTQ08150	BOLT, HEX, 1/2-13UNC x 1.50, 8, PLT
5	1	EACH	BTQ08125	BOLT, HEX, 1/2-13UNC x 1.25, 8, PLT
4	4	EACH	BTC12035	BOLT, HEX, 12 x 1.75 x 35mm, 10.9, PLT
3	2	EACH	BMT10011	BKT, TENR, BLOCK, OFFSET, 3mm
2	1	EACH	BMCS90020	BKT, ALT, WELDM'T, CURB SIDE, TM-65/55, '16
1	2	EACH	BEL11040	BELT, A gr, 1040mm (41")
ITEM	QTY	U/M	PART NUMBER	DESCRIPTION

BILL OF MATERIALS

3	ADDED KBA84064 SHIM BAG KIT.	02/03/2022	VALJ	
2	ADDED SCD05513.	05/11/2021	JRR	
1	WAS TRD08060, NOW TRD08080	10/2/2018	JRR	
0	RELEASED TO PRODUCTION.	8/3/2016	JRR	
REV:	ECN:	DESCRIPTION:	DATE:	BY:
THIS DRAWING CONTAINS PROPRIETARY CONFIDENTIAL INFORMATION OWNED BY TRANSARCTIC CANADA INC. THE DOCUMENT AND THE INFORMATION IN IT ARE NOT TO BE USED, DISCLOSED OR REPRODUCED WITHOUT EXPRESS WRITTEN PERMISSION OF THE COMPANY.				
UNSPECIFIED TOLERANCES: [ALT. DIM.]				
ONE DECIMAL PLACE (X) .50 [0.05] MM (INCH)				
TWO DECIMAL PLACE (XX) .25 [0.10] MM (INCH)				
THREE DECIMAL PLACE (XXX) .10 [0.05] MM (INCH)				
FRACTIONAL: +/- .002" ANGULAR: +/- .50°				
THIRD ANGLE PROJECTION				
DRAWN		08/03/16		
vjakowlew				
CHECKED		08/03/16		
Jose Rodriguez				
MFG		8/3/2016		TITLE KIT, ALTERNATOR, TM-55/65, CURB SIDE, '13
James Stewart				
APPROVED				
Dale Mason		08/03/16		SIZE C
DRAWING UNIT OF MEASURE:		MM [INCH]		DWG NO KAC65501
SCALE		1:4		REV 3
SHEET		1 OF 1		

8 7 6 5 4 3 2 1

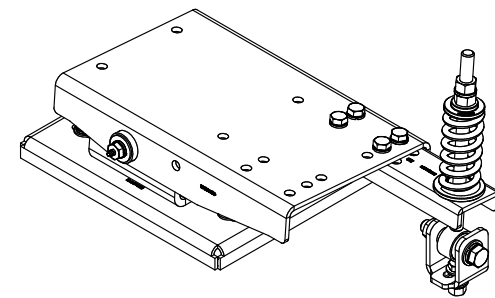
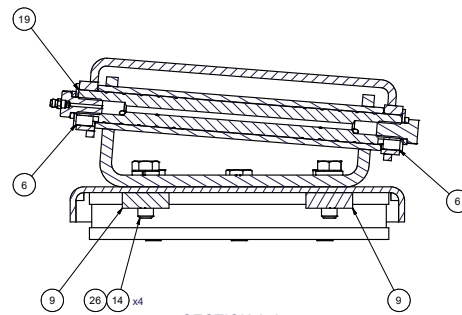
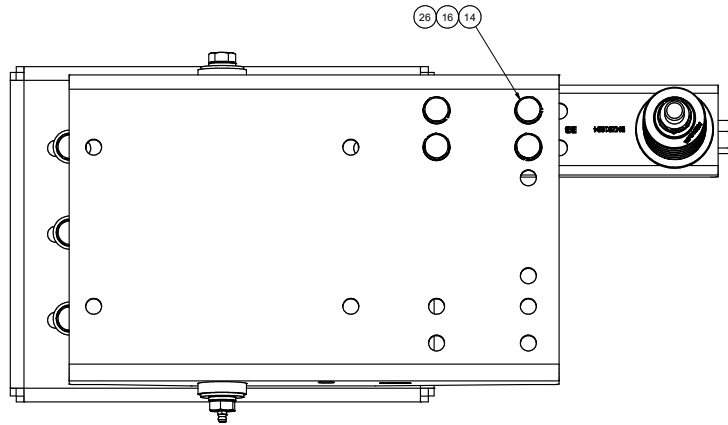

ISOMETRIC VIEW
SCALE 1/3

SECTION A-A

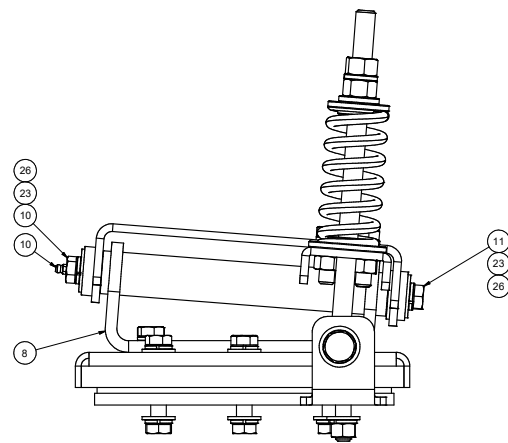
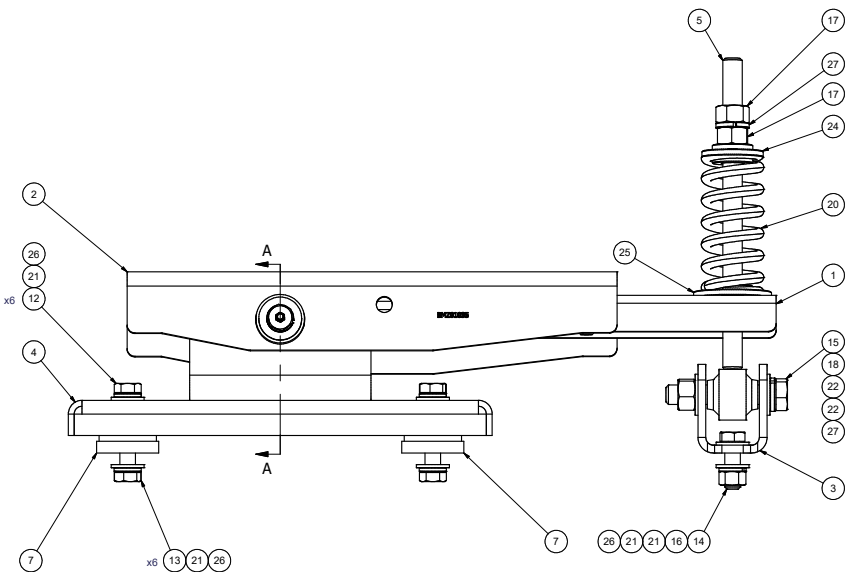

27	2	EACH	WLO10000	WASHER, LOCK, 5/8", 8, PLT
26	23	EACH	WLO08000	WASHER, LOCK, 1/2", 8, PLT
25	1	EACH	WFS27001	WASHER, FLAT, DBL STEP, 28mm, 63.5, PLT
24	1	EACH	WFS16001	WASHER, FLAT, DBL STEP, 16mm, 50mm, PLT
23	2	EACH	WFS08001	WASHER, FLAT, 1/2", 8, USS, PLT
22	2	EACH	WFO10000	WASHER, FLAT, 5/8", 8, PLT
21	14	EACH	WFO08000	WASHER, FLAT, 1/2", 8, PLT
20	1	EACH	SPR00002	SPRING, COMP, R/H, 110 x 50 x 8.4, RED
19	1	EACH	PTSO1010	SHAFT, STL, GREASE, ADM TRANSIT, '12
18	1	EACH	NTQ10001	NUT, HEX, 5/8-18UNC, 8, PLT
17	2	EACH	NTQ10000	NUT, HEX, 5/8-11UNC, 8, PLT
16	5	EACH	NTQ08000	NUT, HEX, 1/2-13UNC, 8, PLT
15	1	EACH	BTQ10351	BOLT, HEX, 5/8-18UNC x 3.50, 8, PLT
14	9	EACH	BTQ08150	BOLT, HEX, 1/2-20UNC x 1.25, 8, PLT
13	6	EACH	BTQ08126	BOLT, HEX, 1/2-20UNC x 1.00, 8, PLT
12	6	EACH	BTQ08101	BOLT, HEX, 1/2-20UNC x 1.00, 8, PLT
11	1	EACH	BTQ08100	BOLT, HEX, 1/2-13UNC x 1.00, 8, PLT
10	1	EACH	BTM08100	BOLT, 1/2-13 x 1.0" w/ GREASE NIPPLE FTG
9	2	EACH	BMZ01047	BKT, BAR, SLIDE NUT, ADJ, TRANS ADM, '12
8	1	EACH	BMZ01044	BKT, ASSY, CRADLE PIVOT, ADM TRANSIT, '12
7	2	EACH	BMZ01042	VIBRATION ISOLATOR, BAR, 9.63 x 2 x 1.50
6	2	EACH	BMZ01041	Shaft Key, 5/16" SQ x .540" Long
5	1	EACH	BMZ01040	BKT, ASSY, THRD ROD, ISOLATOR, ADM, '12
4	1	EACH	BMZ01038	BKT, MAIN, BASE PL, ADM, '12
3	1	EACH	BMZ01037	BKT, FORK, KNUCKLE-JOINT, ADM, '12
2	1	EACH	BMZ01035	BKT, MAIN, PIVOT, ASSY, ADM TRANSIT, '12
1	1	EACH	BMZ01034	BKT, SPRING, SUPPORT ARM, ADM, '12
ITEM	QTY	U/M	PART NUMBER	DESCRIPTION

REV	ECN	DESCRIPTION	DATE	BY
0		RELEASED TO PRODUCTION	6/12/2020	JRR
1			6/12/2020	Val Jakowlew
2			6/12/2020	James Stewart
3			6/12/2020	Ron Ingram
4			6/12/2020	Dale Mason

DRAWN: jrodriguez 6/12/2020
 CHECKED: Val Jakowlew 6/12/2020
 APPROVED: Dale Mason 6/12/2020

TRANSARCTIC INC.
 TITLE: MT KIT, PS, PLATFORM, TRANSIT, ADM, '20
 SIZE: D
 DWG NO: KBB00002
 SCALE: 1:2
 SHEET 1 OF 1

NOTES:
 1) USE SERVICABLE THREADLOCKER ON ALL FASTENERS TO ENGINE COMPONENTS AND TORQUE ALL BOLTS TO S.A.E. SPECIFICATIONS.
 2) SEE "TRANSARCTIC A/C COMPRESSOR MOUNT INSTALLATION DISCLAIMER".

UNSPECIFIED TOLERANCES: ALL DIMS IN INCHES
 ONE DECIMAL PLACE (.X) .005
 TWO DECIMAL PLACES (.XX) .002
 THREE DECIMAL PLACES (.XXX) .001
 FRACTIONAL IN 1/16" .001



DRAWING UNIT OF MEASURE: MM (INCH)

SCALE: 1:2
 SHEET 1 OF 1

8 7 6 5 4 3 2 1

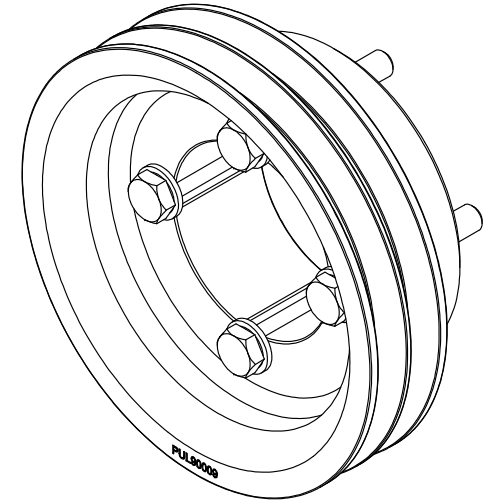
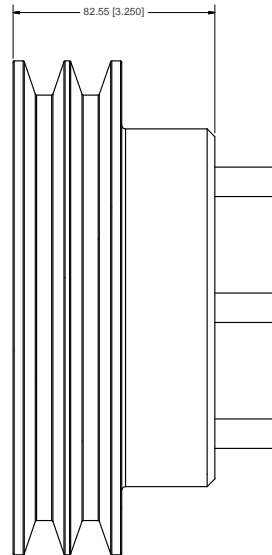
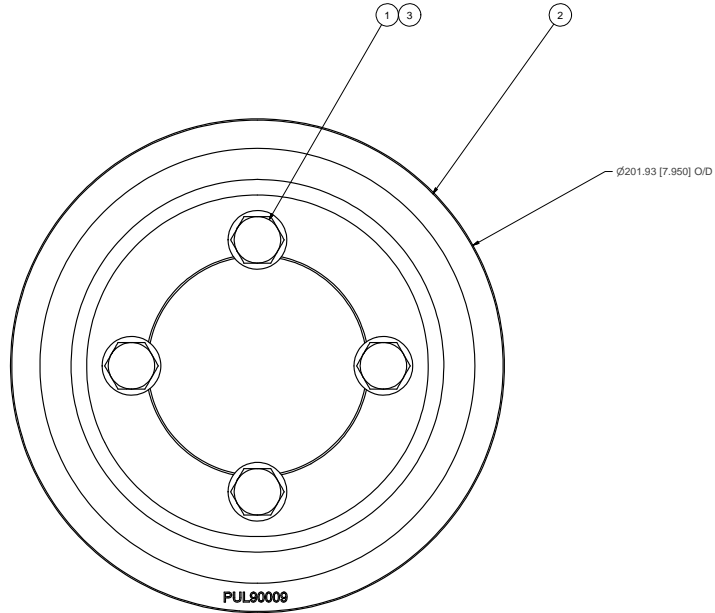

- NOTES:
- 1) USE SERVICABLE THREADLOCKER ON ALL FASTENERS TO ENGINE COMPONENTS AND TORQUE **ALL** BOLTS TO S.A.E. SPECIFICATIONS.
 - 2) SEE "TRANSARCTIC A/C COMPRESSOR MOUNT INSTALLATION DISCLAIMER".
 - 3) WEIGHT: 16.41 LB

ITEM	QTY	U/M	PART NUMBER	DESCRIPTION
3	4	EACH	WFS12002	WASHER, FLAT, HDN, 12mm, STL, BLK
2	1	EACH	PUL90009	PULLEY, CRANK, ISL-G, 8.9L, 2B/X, 8", '17
1	4	EACH	BTCT2080	BOLT, HEX, 12 x 1.75 x 80mm, 10.9, FLT

BILL OF MATERIALS

TRANSARCTIC INC.

DRWN	JRodriguez	12/16/2016	TITLE
CHKD	Jose Rodriguez	12/16/2016	
REV	ECN	DESCRIPTION	DATE
		RELEASED TO PRODUCTION	12/16/2016
		BY: Jose Rodriguez	
		DATE: 12/16/2016	
		BY: MFG	
		DATE: 12/16/2016	
		APPROVED	
		DATE: 12/16/2016	
		DATE: 12/16/2016	
UNSPECIFIED TOLERANCES:			MM (INCH)
ONE DECIMAL PLACE (X.0)	±0.10	FRONT	THIRD ANGLE PROJECTION
TWO DECIMAL PLACE (X.00)	±0.02	DRILL	
THREE DECIMAL PLACE (X.000)	±0.002	DRILL	
FRACTIONAL (1/16")	±0.005	ANGULAR	
DRAWING UNIT OF MEASURE:			MM (INCH)
SCALE:			1:1
DWG NO:			KPC90009
REV:			0
SHEET:			1 OF 1

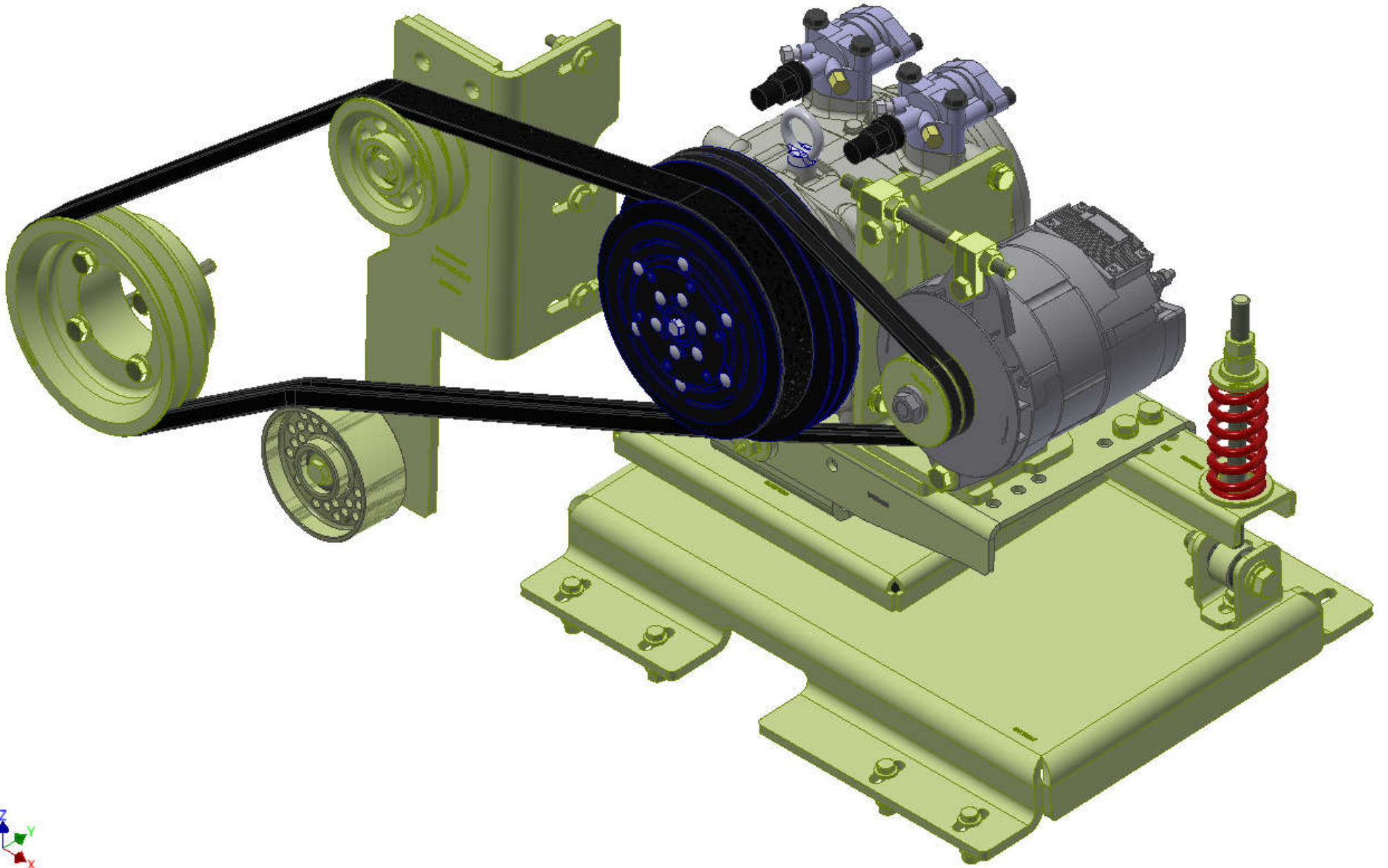

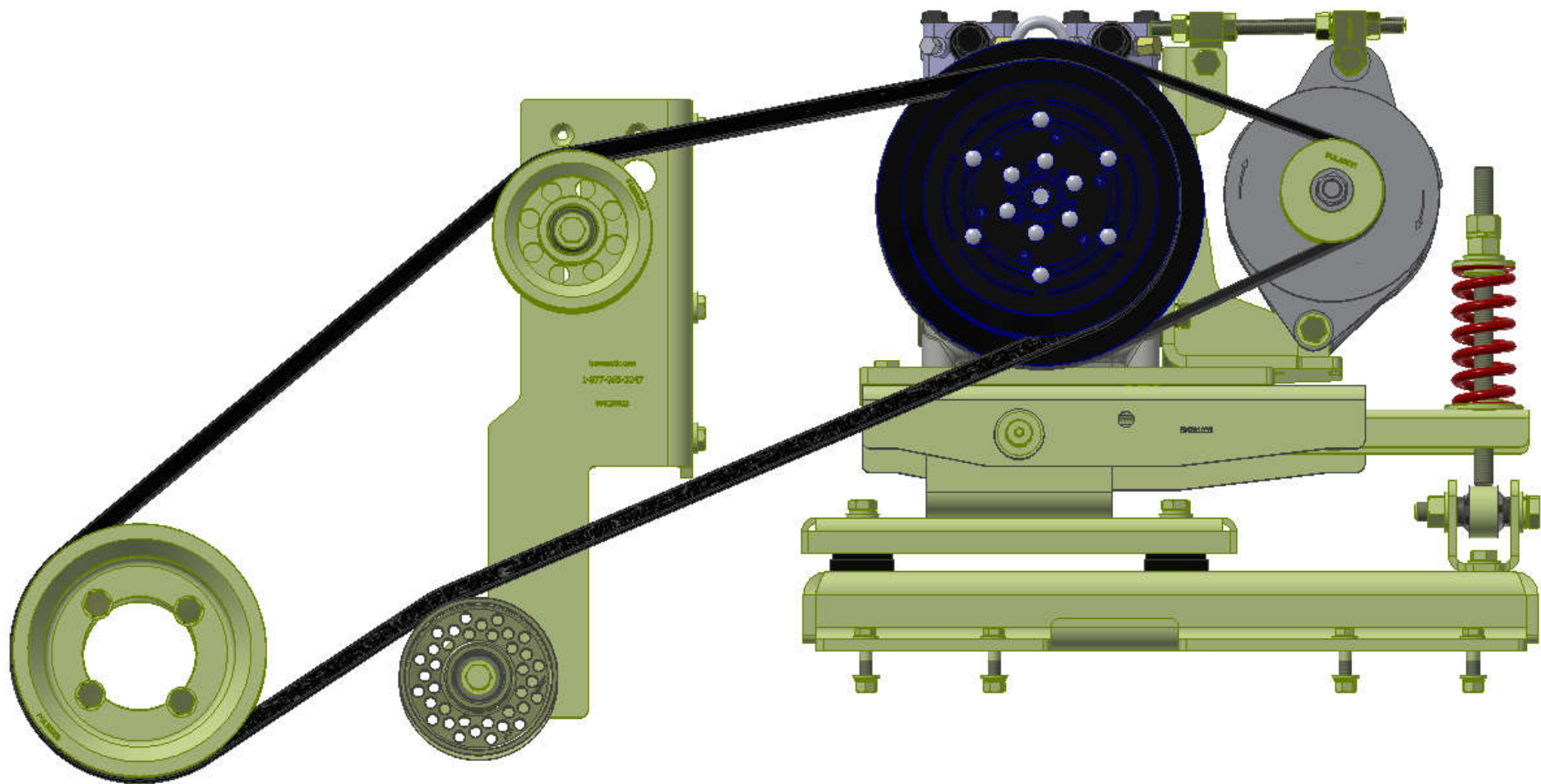

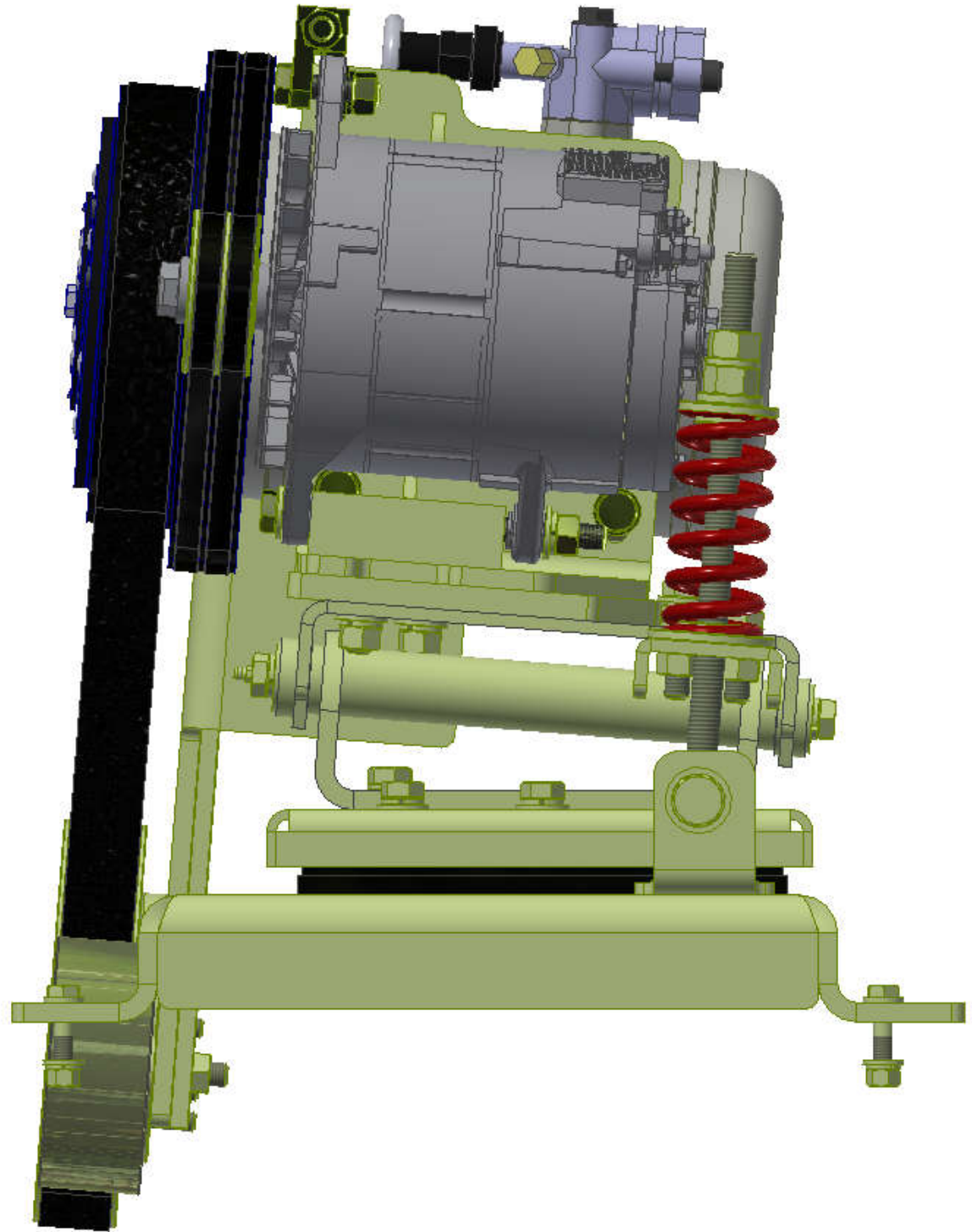

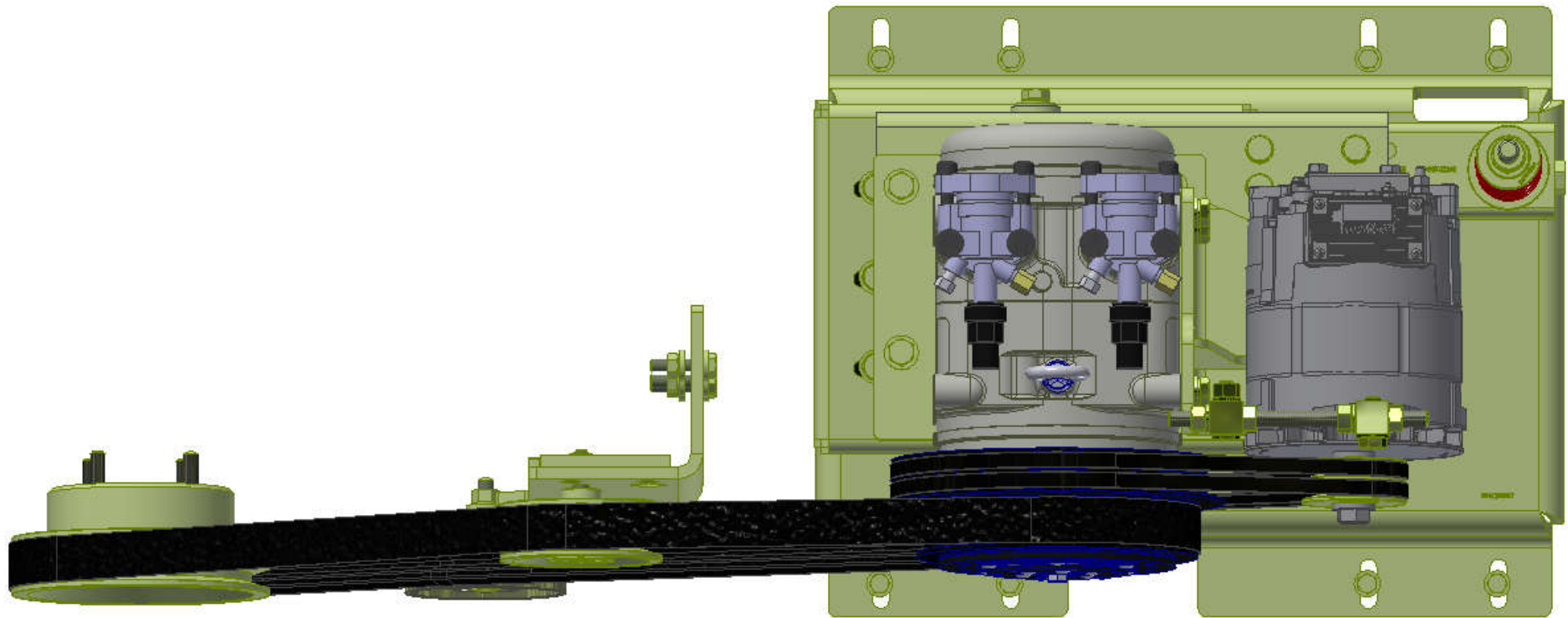

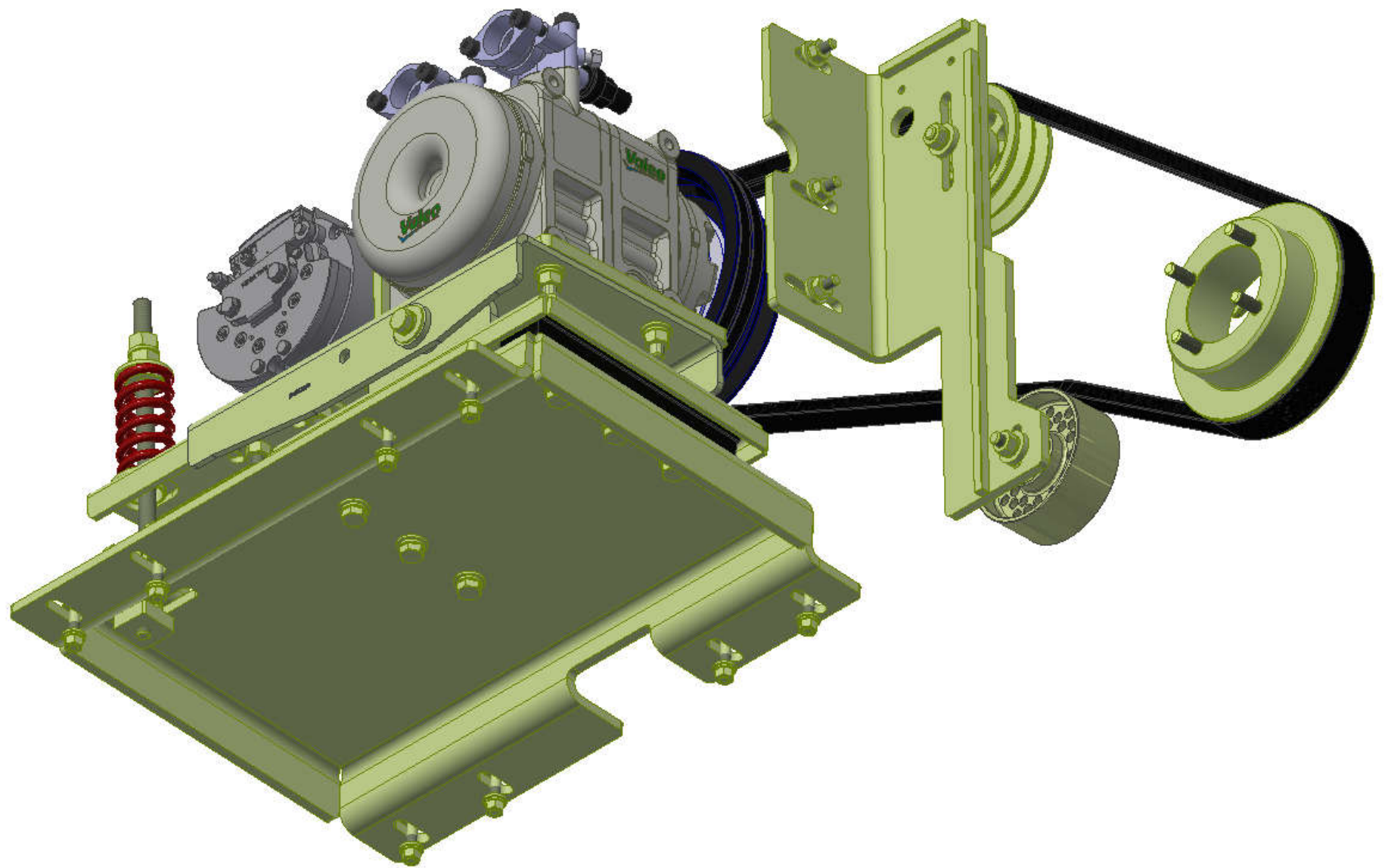

TransArctic A/C Compressor Mount Installation Disclaimer

All compressor mounts should be installed by qualified and trained personnel using proper tools and equipment in safe working conditions following industry standard guidelines for motor vehicle service and repair.

The installer of any compressor mount purchased from TransArctic must undertake all responsibility of issues arising from that compressor bracket being installed on any vehicle. As well as insure that a **proper and sufficient ground** is established between the compressors' clutches and the vehicle's engine. Mount functionality, operation and durability can all be compromised by an incompetent installation.

Due to the many different situations, parameters and application criteria, which are beyond the compressor mount manufacturer's control, TransArctic does not warrant design, durability, or operational functionality of any compressor mount improperly installed by another party.

With no implied guarantees it is the mount installer's strict responsibility to determine safety and functionality, of the compressor mount, at the time of installation.

Please contact TransArctic with any issue arising from installation so we may better improve the product. If you have any reservations about the compressor mount integrity contact TransArctic immediately at 1-877-COLD-AIR.

Mark OEM tensioner location

Install Kit

Check for Interferences

Check to ensure that the proper OEM tensioner orientation is maintained

Run engine with A/C system engaged for at least 10 minutes to run in belt

Check OEM tensioner orientation and adjust as required

Responsabilidad limitada de TransArctic en la instalación del soporte del compresor

Todos los soportes de los compresores deben ser instalados por personas calificadas y entrenadas, usando para ello los equipos y herramientas necesarios para esta labor en buenas condiciones y según las normas y guías para el servicio y/o reparación de motores de vehículos.

El instalador de los soportes comprados en TransArctic asume toda la responsabilidad de cualquier problema que surga en el soporte del compresor al vehículo; de igual manera es responsable que el cable a tierra sea conectado entre el embrague del compresor y el motor del vehículo.

Se advierte que el buen funcionamiento y la durabilidad del soporte pueden ser comprometidos por defectos en su instalación.

Debido a las diversas situaciones que se puedan presentar fuera del control del fabricante, TransArctic no garantiza el diseño, la durabilidad o el correcto funcionamiento de cualquier equipo inapropiadamente instalado por terceros.

Esta sobreentendido que el Instalador del montaje del compresor es estrictamente responsable de la seguridad y funcionamiento del equipo en el momento de la instalación.

Si tuviera algún problema o duda acerca de la instalación del soporte del compresor pongase en contacto inmediatamente con TransArctic al teléfono 1-877-COLD-AIR de modo que podamos mejorar nuestro producto.

Note la ubicación del medidor de tensión OEM

Instale el equipo

Controlar si hay interferencias.

Asegurese que el medidor de tensión mantenga la orientación justa.

Encienda el motor por lo menos 10 minutos con el sistema A/C enganchado para que la correa corra

Controle la orientación justa del medidor de tensión y ajuste a las condiciones requeridas del fabricante