

Bill of Materials Listing

TransArctic Canada Inc.

7/21/2021
Page 1 of 1

Product Number	Date	Description	Uof M	Weight	Yield		
Line	Qty	Component Prod#	Rev#	Description	Bin	Unit	
TPK65772	1/7/2019	0		Kit, Temp, ISB, 6.7L, BBCV, TM-16, '19		34.88	0
10	1	BEL61511		Belt, 6gr, 1511mm (59.5") (5060595)		each	
20	1	BMC67131	2	BKT, MAIN, WELDM'T, 6.7L, ISB, COMP, 3		each	
30	1	BMC67188	1	Bkt, Spacer, Block, 1.2", TPK67871		each	
35	1	FSP63810	0	Spacer, Fan, Pulley, ISB, 38.10mm(1.5")		each	
40	1	PUL67006	0	Pulley, Crank, ADD-ON, Cum, ISB, 6.7, P6		each	
50	1	TEN80005		Tenr, HD Spring, BackSide, CCW (89430)		each	
60	4	BTC08100		Bolt, Hex, 8 x 1.25 x 100mm, 10.9, Plt		each	
70	1	BTC10030		Bolt, Hex, 10 x 1.5 x 30mm, 10.9, Plt		each	
90	1	BTC10040		Bolt, Hex, 10 x 1.5 x 40mm, 10.9, Plt,FT		each	
100	1	BTC10045		Bolt, Hex, 10 x 1.5 x 45mm, 10.9, Plt,FT		each	
110	2	BTC10070		Bolt, Hex, 10 x 1.5 x 70mm, 10.9, Plt		each	
120	1	BTC10090		Bolt, Hex, 10 x 1.5 x 90mm, 10.9, Plt		each	
125	6	BTC10130		Bolt, Hex, 10 x 1.5 x 130mm, 10.9, Plt		each	
130	6	CSS12090		Capscrew, SH, 12 x 1.25 x 90mm, 12.9,BLK		each	
150	4	WFA08000		Washer, Flat, 8mm, 8.8, Plt		each	
160	5	WFA10000		Washer, Flat, 10mm, 8.8, Plt		each	
170	4	WLA08000		Washer, Lock, 8mm, 8.8, Plt		each	
180	6	WLA10000		Washer, Lock, 10mm, 8.8, Plt		each	

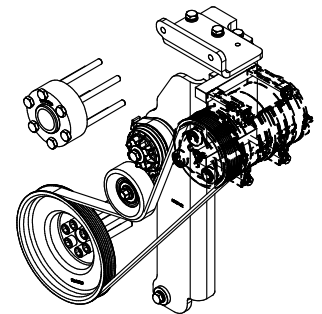
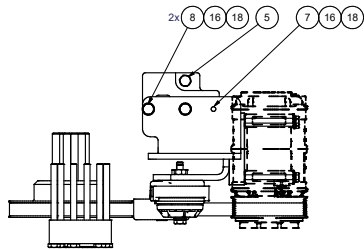

ISOMETRIC VIEW

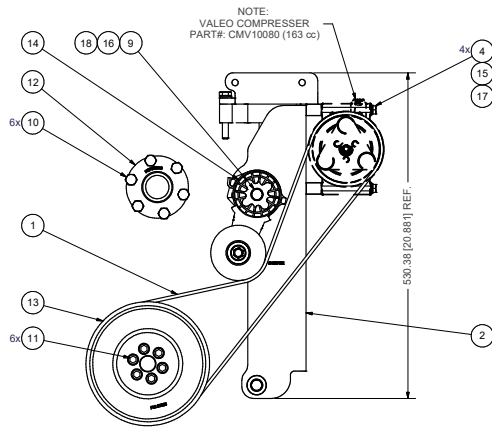

NOTE:
VALEO COMPRESSOR
PART#: CMV10080 (163 cc)

NOTE:
INSTALL THE 6 GR. BELT ON THE
FRONT 6 GROOVES OF THE
COMPRESSOR PULLEY.

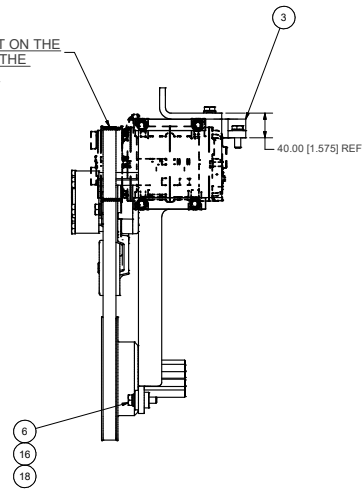

NOTES:

- 1) USE SERVICABLE THREADLOCKER ON ALL FASTENERS TO ENGINE COMPONENTS AND TORQUE **ALL** BOLTS TO S.A.E. SPECIFICATIONS.
- 2) SEE "TRANSARCTIC A/C COMPRESSOR MOUNT INSTALLATION DISCLAIMER".

ITEM	QTY	U/M	PART NUMBER	DESCRIPTION
18	6	EACH	WLA10000	WASHER, LOCK, 10mm, 8.8, PLT
17	4	EACH	WLA08000	WASHER, LOCK, 8mm, 8.8, PLT
16	5	EACH	WFA10000	WASHER, FLAT, 10mm, 8.8, PLT
15	4	EACH	WFA08000	WASHER, FLAT, 8mm, 8.8, PLT
14	1	EACH	TENR00005	TENR, HD SPRINGS, BACKSIDE, CCW (89430)
13	1	EACH	PUL67006	PULLEY, CRANK, ADD-ON, CUM, ISB, 6.7, P6
12	1	EACH	FSP63810	SPACER, FAN, PULLEY, ISB, 38.1mm (1.5")
11	6	EACH	CSS12090	CAPSCREW, SH, 12 x 1.25 x 90mm, 12.9, PLT
10	6	EACH	BTC10130	BOLT, HEX, 10 x 1.5 x 130mm, 10.9, PLT
9	1	EACH	BTC10090	BOLT, HEX, 10 x 1.5 x 90mm, 10.9, PLT
8	2	EACH	BTC10070	BOLT, HEX, 10 x 1.5 x 70mm, 10.9, PLT
7	1	EACH	BTC10045	BOLT, HEX, 10 x 1.5 x 45mm, 10.9, PLT
6	1	EACH	BTC10040	BOLT, HEX, 10 x 1.5 x 40mm, 10.9, PLT
5	1	EACH	BTC10030	BOLT, HEX, 10 x 1.5 x 30mm, 10.9, PLT
4	4	EACH	BTC08100	BOLT, HEX, 8 x 1.25 x 100mm, 10.9, PLT
3	1	EACH	BMC67188	BKT, SPACER, BLOCK, 1.2", TPK67871
2	1	EACH	BMC67131	BKT, MAIN, WELDM'T, 6.7L, ISB, COMP, 3
1	1	EACH	BEL61511	Belt, 6gr, 1511mm (59.5") (6060595)

Parts List

DRAWN
vjakowlew
7/1/2021
CHECKED
Jose Rodriguez
7/1/2021
APPROVED
James Stewart
7/1/2021
Dale Mason
7/1/2021

TRANSARCTIC INC.
TITLE

REV	ECN	DESCRIPTION	DATE	BY
0		RELEASED TO PRODUCTION	07/23/2021	VAL

MT. KIT, ISB, 6.7L, BBCV, +1 TM-16, '19

UNSPECIFIED TOLERANCES:
ONE DECIMAL PLACE (X1) .1mm (1/16")
TWO DECIMAL PLACE (X10) .02mm (1/32")
THREE DECIMAL PLACE (X30) .003mm (1/100")
FRACTIONAL (X1/16) 1/16" (1.59375mm)

SIZE DWG NO
D TPK65772
SCALE
SHEET 1 OF 1



DRAWING UNIT OF MEASURE: MM (INCH)

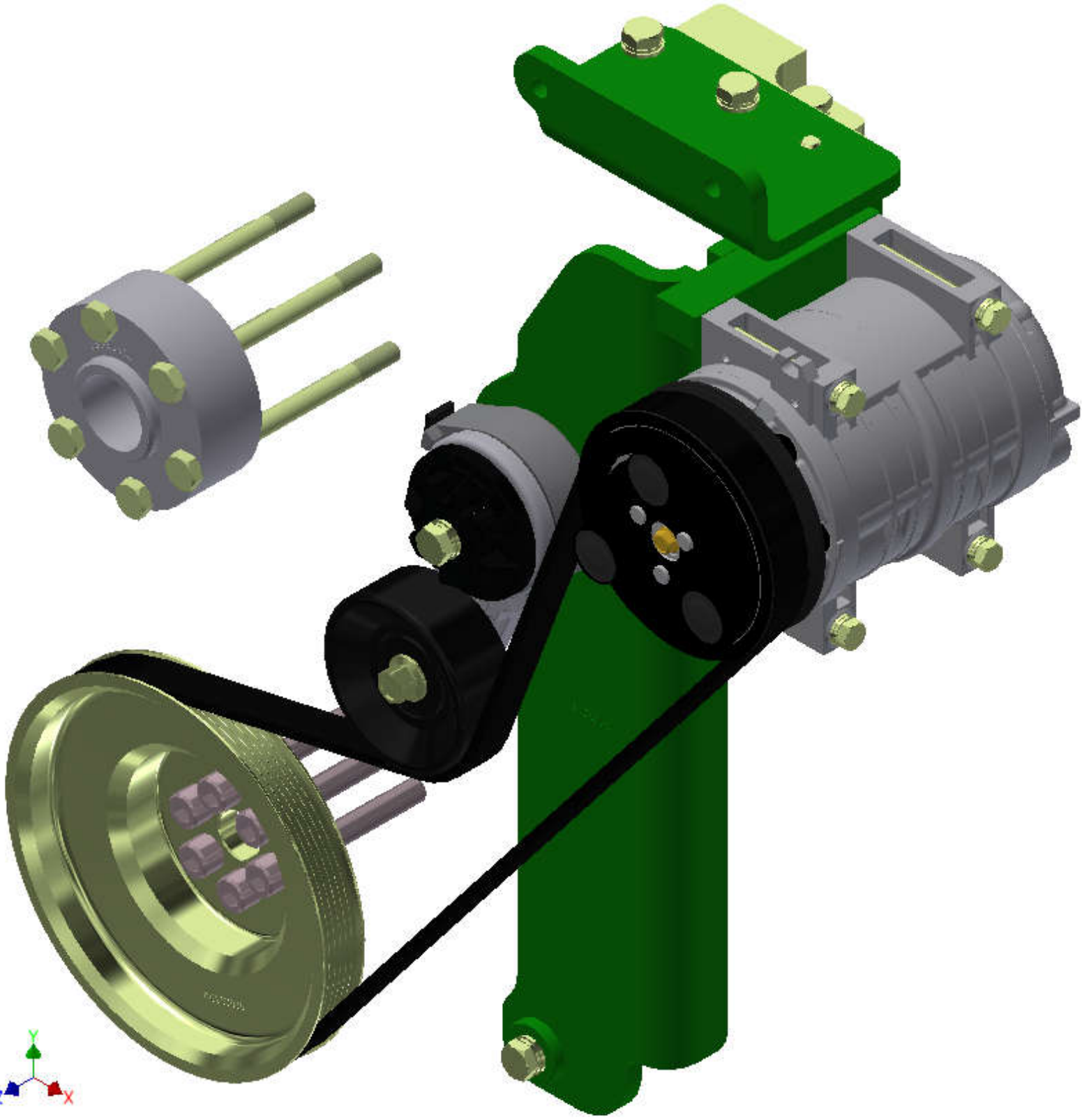

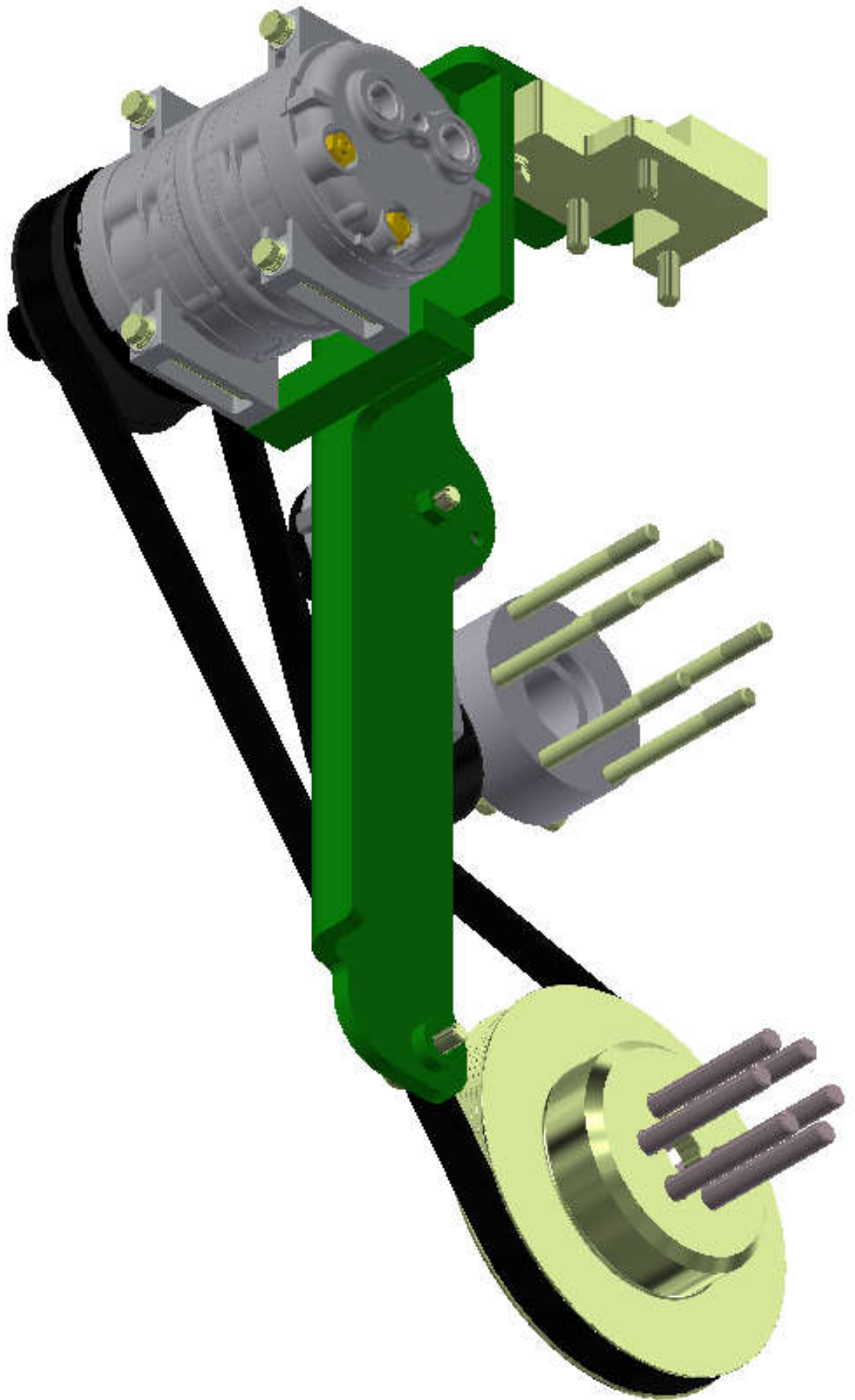

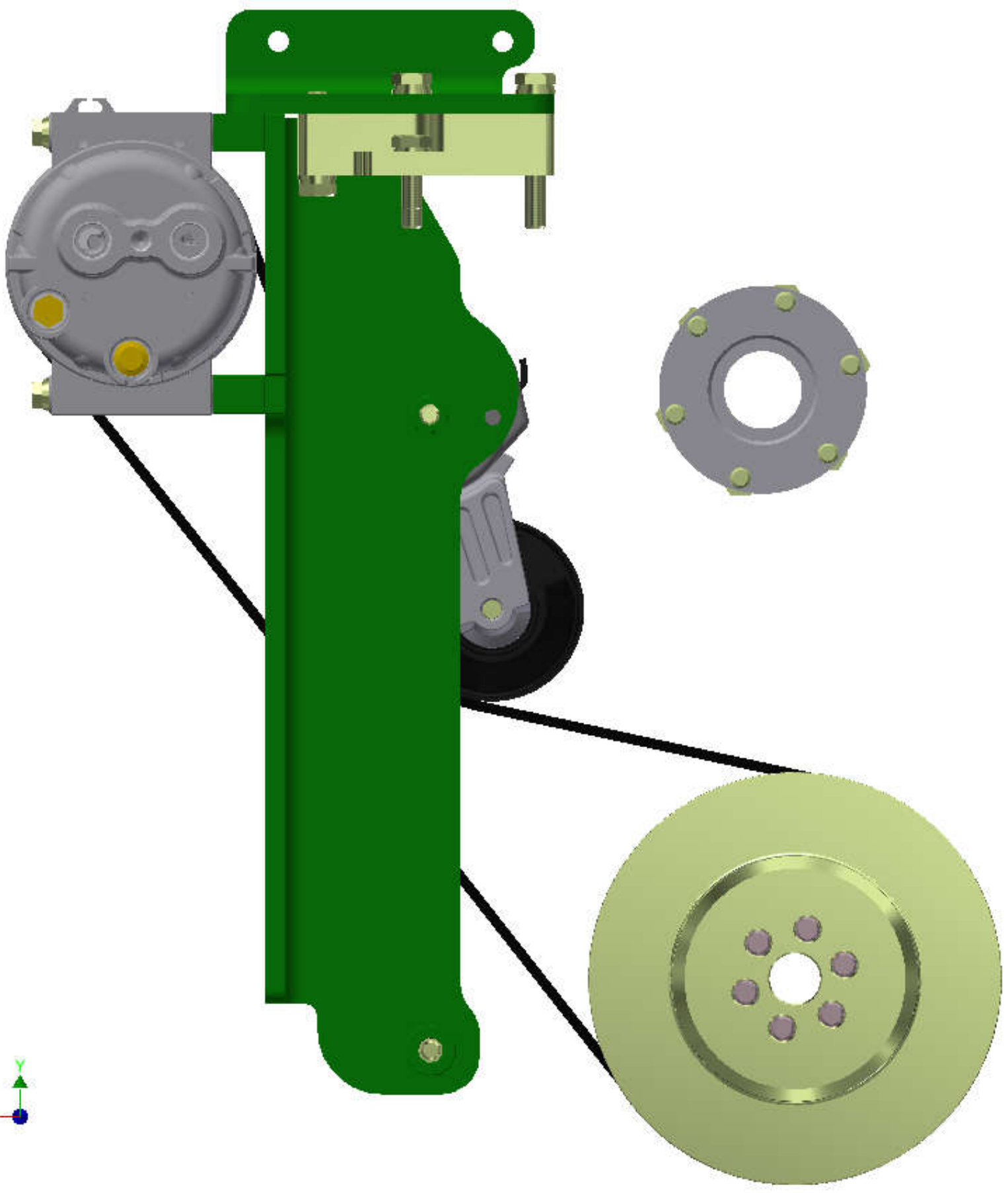
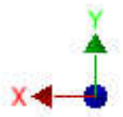

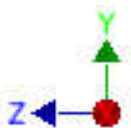

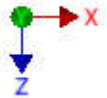
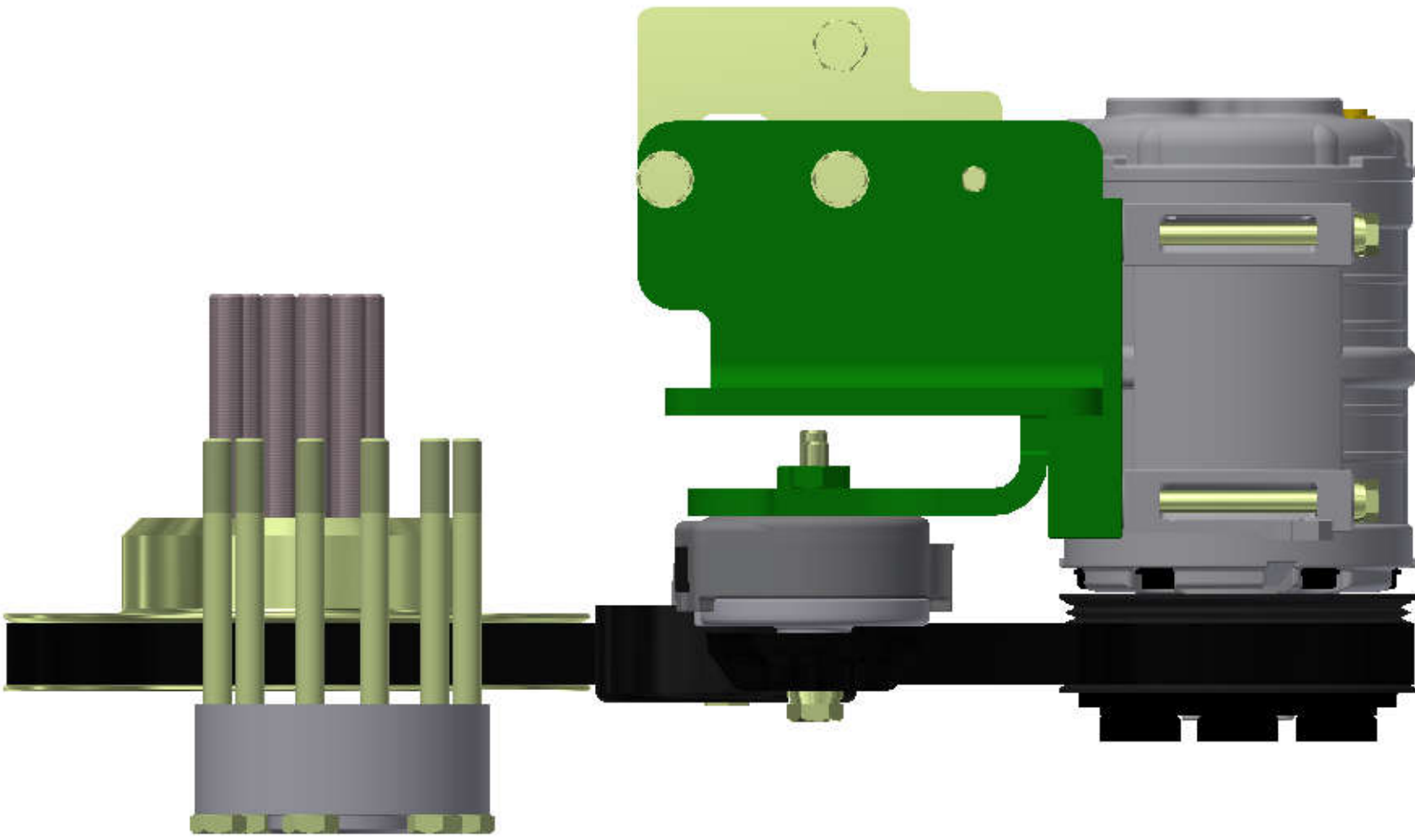

TransArctic A/C Compressor Mount Installation Disclaimer

All compressor mounts should be installed by qualified and trained personnel using proper tools and equipment in safe working conditions following industry standard guidelines for motor vehicle service and repair.

The installer of any compressor mount purchased from TransArctic must undertake all responsibility of issues arising from that compressor bracket being installed on any vehicle. As well as insure that a **proper and sufficient ground** is established between the compressors' clutches and the vehicle's engine. Mount functionality, operation and durability can all be compromised by an incompetent installation.

Due to the many different situations, parameters and application criteria, which are beyond the compressor mount manufacturer's control, TransArctic does not warrant design, durability, or operational functionality of any compressor mount improperly installed by another party.

With no implied guarantees it is the mount installer's strict responsibility to determine safety and functionality, of the compressor mount, at the time of installation.

Please contact TransArctic with any issue arising from installation so we may better improve the product. If you have any reservations about the compressor mount integrity contact TransArctic immediately at 1-877-COLD-AIR.

Mark OEM tensioner location

Install Kit

Check for Interferences

Check to ensure that the proper OEM tensioner orientation is maintained

Run engine with A/C system engaged for at least 10 minutes to run in belt

Check OEM tensioner orientation and adjust as required

Responsabilidad limitada de TransArctic en la instalación del soporte del compresor

Todos los soportes de los compresores deben ser instalados por personas calificadas y entrenadas, usando para ello los equipos y herramientas necesarios para esta labor en buenas condiciones y según las normas y guías para el servicio y/o reparación de motores de vehículos.

El instalador de los soportes comprados en TransArctic asume toda la responsabilidad de cualquier problema que surga en el soporte del compresor al vehículo; de igual manera es responsable que el cable a tierra sea conectado entre el embrague del compresor y el motor del vehículo.

Se advierte que el buen funcionamiento y la durabilidad del soporte pueden ser comprometidos por defectos en su instalación.

Debido a las diversas situaciones que se puedan presentar fuera del control del fabricante, TransArctic no garantiza el diseño, la durabilidad o el correcto funcionamiento de cualquier equipo inapropiadamente instalado por terceros.

Esta sobreentendido que el Instalador del montaje del compresor es estrictamente responsable de la seguridad y funcionamiento del equipo en el momento de la instalación.

Si tuviera algún problema o duda acerca de la instalación del soporte del compresor pongase en contacto inmediatamente con TransArctic al teléfono 1-877-COLD-AIR de modo que podamos mejorar nuestro producto.

Note la ubicación del medidor de tensión OEM

Instale el equipo

Controlar si hay interferencias.

Asegurese que el medidor de tensión mantenga la orientación justa.

Encienda el motor por lo menos 10 minutos con el sistema A/C enganchado para que la correa corra

Controle la orientación justa del medidor de tensión y ajuste a las condiciones requeridas del fabricante