

8 7 6 5 4 3 2 1

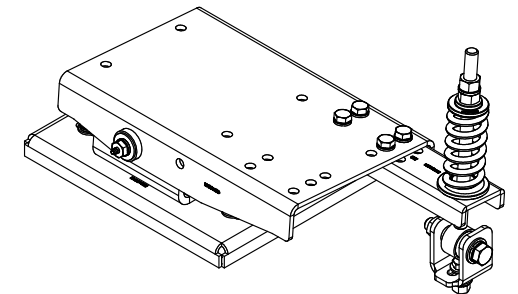

ISOMETRIC VIEW  
SCALE 1/3

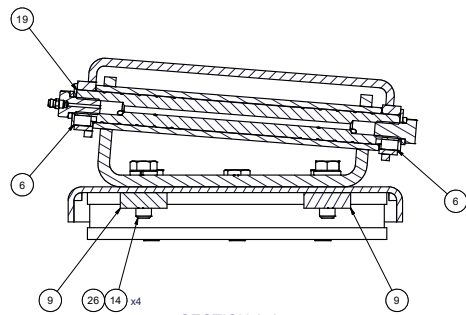
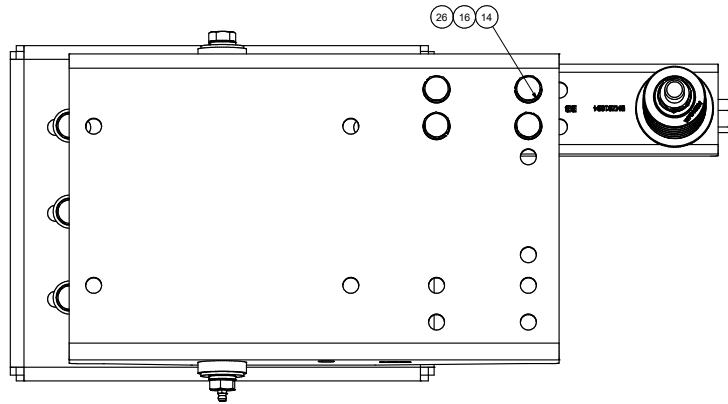
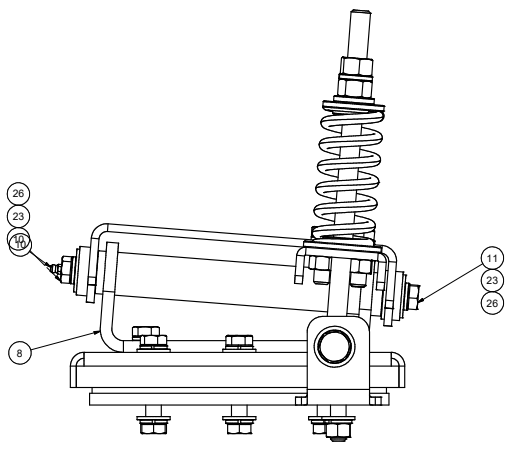
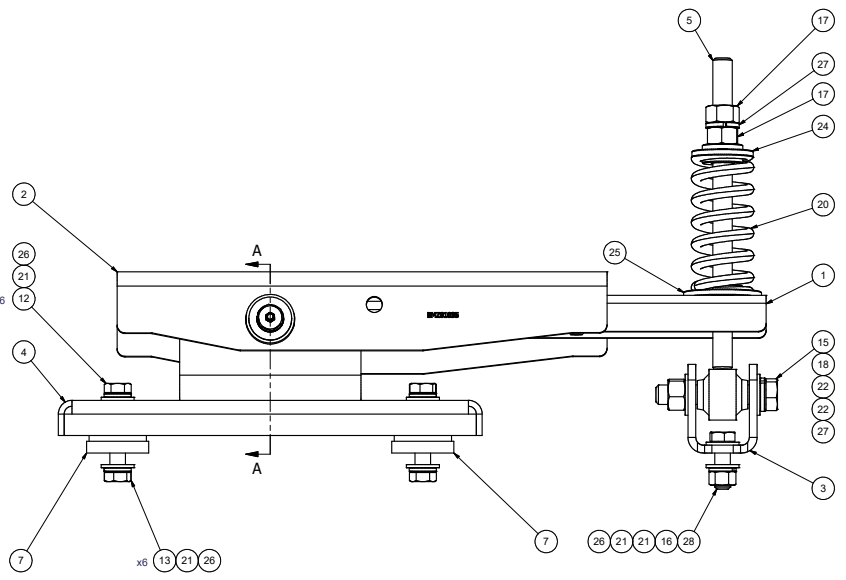

ITEM	QTY	U/M	PART NUMBER	DESCRIPTION
28	1	EACH	100007	BOLT, HEX, 1/2-13UNC x 1.50, 8, PLT
27	2	EACH	WLO10000	WASHER, LOCK, 5/8", 8, PLT
26	23	EACH	WLO08000	WASHER, LOCK, 1/2", 8, PLT
25	1	EACH	WFS27001	WASHER, FLAT, DBL STEP, 28mm, 63.5, PLT
24	1	EACH	WFS16001	WASHER, FLAT, DBL STEP, 16mm, 50mm, PLT
23	2	EACH	WFS08001	WASHER, FLAT, 1/2", 8, USS, PLT
22	2	EACH	WFO10000	WASHER, FLAT, 5/8", 8, PLT
21	14	EACH	WFO08000	WASHER, FLAT, 1/2", 8, PLT
20	1	EACH	SPR00002	SPRING, COMP, R/H, 110 x 50 x 8.4, RED
19	1	EACH	PTSO1010	SHAFT, STL, GREASE, ADM TRANSIT, '12
18	1	EACH	NTQ10001	NUT, HEX, 5/8-18UNC, 8, PLT
17	2	EACH	NTQ10000	NUT, HEX, 5/8-11UNC, 8, PLT
16	5	EACH	NTQ08000	NUT, HEX, 1/2-13UNC, 8, PLT
15	1	EACH	BTQ10351	BOLT, HEX, 5/8-18UNF x 3.50, 8, PLT
14	8	EACH	BTQ08150	BOLT, HEX, 1/2-13UNC x 1.50, 8, PLT
13	6	EACH	BTQ08126	BOLT, HEX, 1/2-20UNF x 1.25, 8, PLT
12	6	EACH	BTQ08101	BOLT, HEX, 1/2-20UNF x 1.00, 8, PLT
11	1	EACH	BTQ08100	BOLT, HEX, 1/2-13UNC x 1.00, 8, PLT
10	1	EACH	BTM08100	BOLT, 1/2-13 x 1.0" w/ GREASE NIPPLE FTG
9	2	EACH	BMZ01047	BKT, BAR, SLIDE NUT, ADJ, TRANS ADM, '12
8	1	EACH	BMZ01044	BKT, ASSY, CRADLE, PIVOT, ADM TRANSIT, '12
7	2	EACH	BMZ01042	VIBRATION ISOLATOR, BAR, 9.63 x 2 x 1.50
6	2	EACH	BMZ01041	Shaft Key, 5/16" SQ x .540" Long
5	1	EACH	BMZ01040	BKT, ASSY, THRD ROD, ISOLATOR, ADM, '12
4	1	EACH	BMZ01038	BKT, MAIN, BASE PL, ADM, '12
3	1	EACH	BMZ01037	BKT, FORK, KNUCKLE-JOINT, ADM, '12
2	1	EACH	BMZ01035	BKT, MAIN, PIVOT, ASSY, ADM TRANSIT, '12
1	1	EACH	BMZ01034	BKT, SPRING, SUPPORT ARM, ADM, '12

NOTES:  
1) USE SERVICABLE THREADLOCKER ON ALL FASTENERS TO ENGINE COMPONENTS AND TORQUE ALL BOLTS TO S.A.E. SPECIFICATIONS.  
2) SEE "TRANSARTIC A/C COMPRESSOR MOUNT INSTALLATION DISCLAIMER".

BILL OF MATERIALS			
DRAWN	6/1/2020	<b>TRANSARTIC INC.</b>	
CHECKED	6/1/2020		
REV	DATE	BY	TITLE
0	6/1/2020	Val Jakowlew	MT KIT, PS, PLATFORM, TRANSIT, ADM, '20
REV	DATE	BY	APPROVED
1	6/1/2020	James Stewart	Dale Mason
2	6/1/2020	Ron Ingram	
3	6/1/2020	Dale Mason	
UNSPECIFIED TOLERANCES:			SIZE
ONE DECIMAL PLACE (X1)	MM	FRACTION	DWG NO
TWO DECIMAL PLACE (X2)	MM	DECIMAL	KBB00002
THREE DECIMAL PLACE (X3)	MM	FRACTION	REV
FRACTIONAL, 1/16"	INCH	DECIMAL	0
DRAWING UNIT OF MEASURE			SCALE
MM (INCH)			1:2
SHEET			1 OF 1

8 7 6 5 4 3 2 1