

AC353 | Narrow

Gen. 4
1-circuit 12 VDC

Ersatzteil-Katalog
Spare Parts Manual
Catalogue Pièces de Rechange

88-50-40-00102-91

Rev. 08.2014



Bestellung von Ersatzteilen

Procedure of ordering Spare Parts

Procédure de commande pièce de rechange

AC 353 I G4 Narrow
1-circuit 12VDC

Einleitung

Im vorliegenden Ersatzteilkatalog sind sämtliche von Eberspächer Sütrak erhältlichen Ersatzteile für die entsprechende Klimaanlage zu-sammengefasst.

Mengenangaben beziehen sich, falls vorhanden, auf die Stückzahl pro Anlage.

Hinweise des Herstellers

Bei Reparaturarbeiten nur die Eberspächer Sütrak Originalersatzteile verwenden. Falls Nicht-Originalteile, die von Eberspächer Sütrak weder geprüft noch zugelassen sind, benutzt werden, so können hierdurch die Sicherheit und der ungestörte Betrieb ernsthaft in Frage gestellt werden. Die Ausstattung kann in diesem Fall ihre Garantie verlieren oder nicht mehr mit den Zulassungsnormen der zulässigen Stellen konform sein. Die vorliegende Anleitung gilt für die Standardmodelle. Sollten bestimmte Teile nicht in der Liste enthalten sein, wenden Sie sich bitte an die unten stehende Adresse.

Introduction

This spare parts manual contains all the spare parts used by Eberspächer Sütrak in this unit. The column quantity shows how many times you will find each piece in one unit.

Manufacturer information

In the event of repair, only use original Eberspächer Sütrak parts. The use of "non original" parts which have not been tested and approved by Eberspächer Sütrak can lead to serious risk for the safety and correct operation of the unit; in certain cases the equipment may no longer be covered by the warranty or comply with the approval standards of the requisite authorities.

This manual shows standard models. For any options that do not figure in the manual, please contact us.

Introduction

Ce catalogue contient toutes les informations concernant les pièces de rechange Eberspächer Sütrak disponi-bles pour ce type de climatiseur. La colonne quantité indique le nom-bre de pièces d'un certain type se trouvant dans le climatiseur.

Informations constructeur

En cas de réparation, utiliser uniquement des pièces d'origine Eberspächer Sütrak. L'utilisation de pièces non testées et approuvées par Eberspächer Sütrak peut conduire à de sérieux problèmes de sécurité et de fonctionnement du groupe d'air conditionné. Dans certain cas l'équipement peut perdre sa garantie ou son approbation auprès des services autorisés.

Ce manuel est valable pour les modèles standards. Si la pièce recherchée ne figure pas dans le manuel, veuillez nous contacter à l'adresse suivante.

Eberspächer Sütrak GmbH & Co KG

Heinkelstr. 5, 71272 Renningen / Germany

Tel: 00 49 (0)7159 923-0, Fax: 00 49 (0)7159 923-269

eMail: parts.suetrak@eberspaecher.com

service.suetrak@eberspaecher.com

...oder wenden Sie sich an Ihren nächsten Eberspächer Sütrak Händler.

Um eine schnelle und richtige Lieferung von Ersatzteilen zu gewährleisten, benötigen wir folgende Informationen:

1. Ihre genaue Anschrift.
2. Gewünschte Versandart: z.B. Post, Luftfracht, Express, usw.
3. Genaue Bezeichnung der Anlage mit Baujahr. (Seriennummer)
4. Stückzahl und Ersatzteilnummer der gewünschten Teile.

... or contact your local Eberspächer Sütrak distributor.

You require a prompt and correct supply. In order to comply with this demand, we need to have the following information:

1. Your exact address.
2. Requested kind of dispatch. For example, surface mail, air mail, air fright, etc.
3. Exact type of unit and year of construction. (serial number)
4. Quantity and code number of the required spare parts.

... ou contacter votre distributeur local Eberspächer Sütrak.

Pour garantir une livraison rapide et correcte, nous avons besoin des informations suivantes:

1. Votre adresse exacte.
2. Le mode d'expédition souhaité. Par exemple, par poste, express, poste aérienne, etc.
3. Des indications précises concernant l'unité de climatisation. (numéro de série)
4. Le numéro de référence et la quantité de pièces.

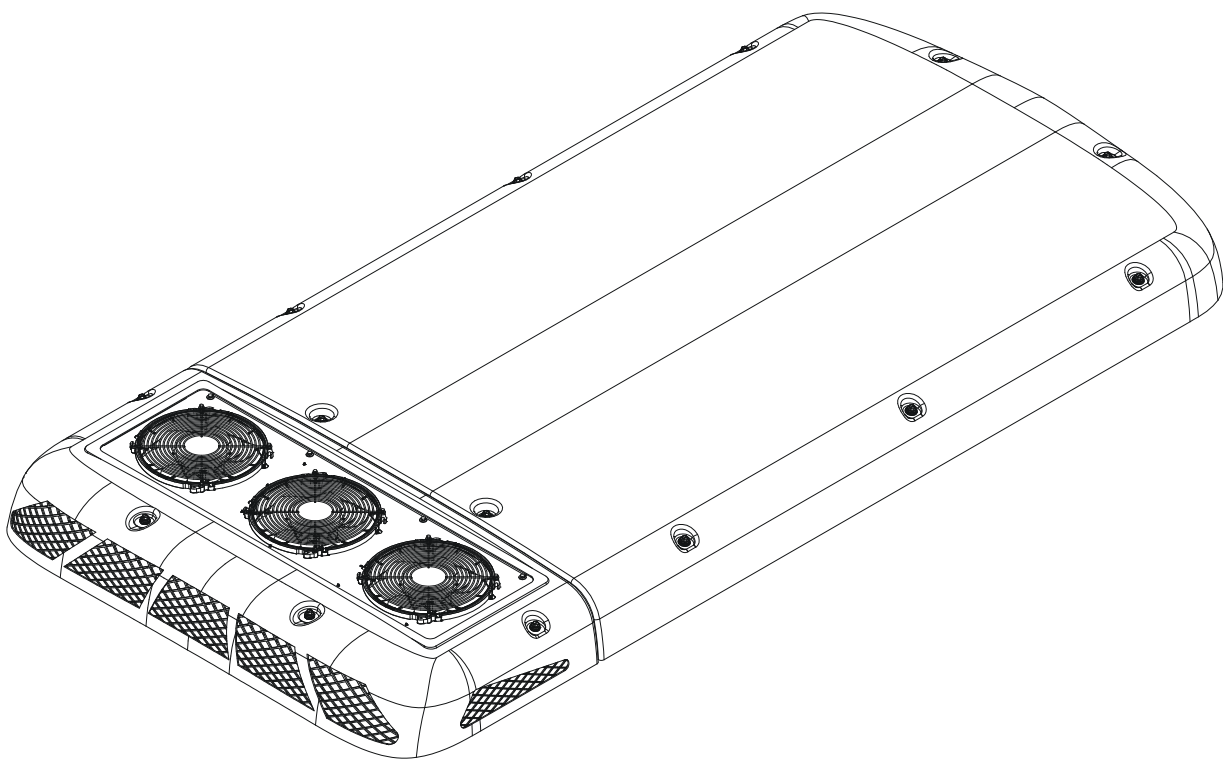

AC 353 I G4 Narrow 1-circuit 12VDC

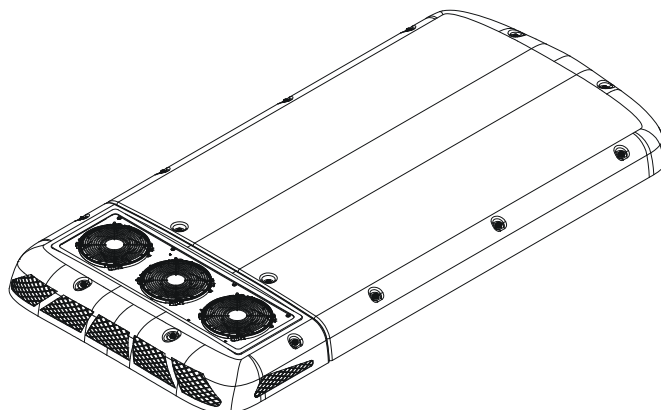

D	Gehäuse und Gebläseteile	6
	Kältetechnische Einzelteile	8
	Elektrisches Bedienteil – Metallgehäuse	10
	Elektrisches Bedienteil – Kunststoffgehäuse	11
	Elektrische Steuerungsteile	12
	Heizung (Optional)	13
	Frischlufklappen (Optional)	14
	Kältemittelanschlüsse	16
	Frontbox-Anschluss	18
	Rückluftgitter	19
GB	Frame an Blower parts	6
	Components Cooling System	8
	Electronic Climate Controller – metal housing	10
	Electronic Climate Controller – plastic housing	11
	Electric Control Parts	12
	Heating (Optional)	13
	Fresh Air Flaps (Optional)	14
	Refrigerant Connections	16
	Frontbox Connection	18
	Return Air Grid	19
F	Chassis et ventilateurs	6
	Composants frigorifiques	8
	Régulateur de climat électronique – boîtier métallique	10
	Régulateur de climat électronique – boîtier plastique	11
	Composants électrique	12
	Chauffage (Optionale)	13
	Volets d'air fraise (Optionale)	14
	Connections frigorifique	16
	Connexion bloc de dégivrage	18
	Grille d' air de retour	19

Gehäuse und Gebläseteile

Frame an Blower parts

Chassis et ventilateurs

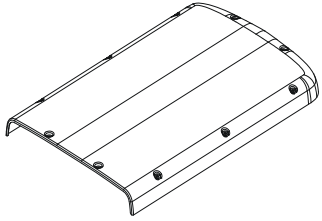

1

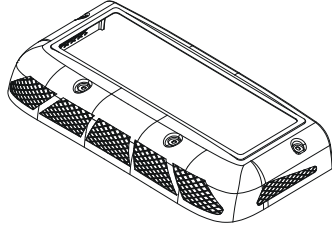

2

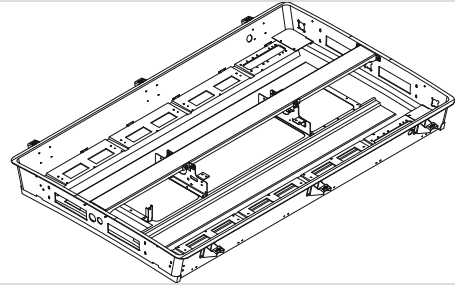

3

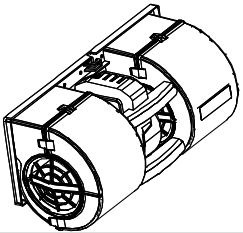

4

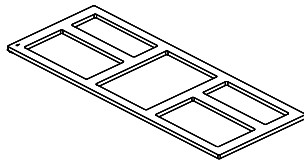

5

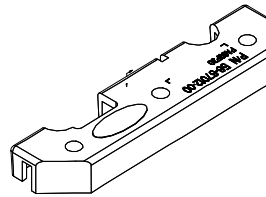

6

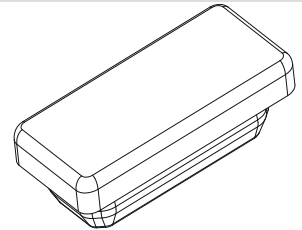

7

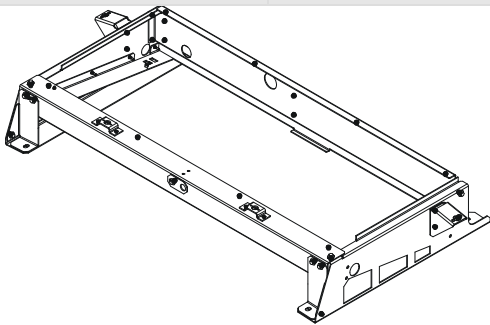

8

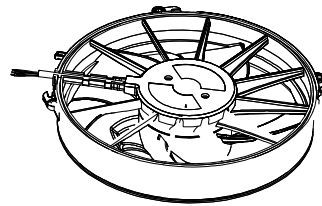

9

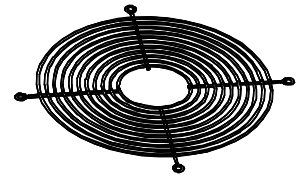

10

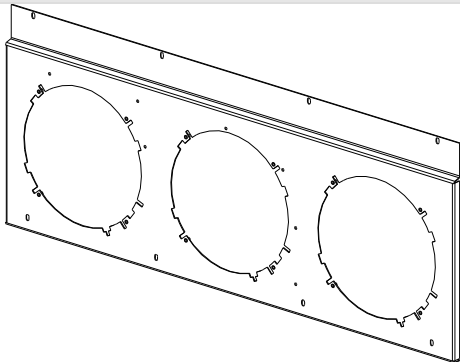

11



Eberspächer

AC 353 I G4 Narrow 1-circuit 12VDC

Pos.	Bezeichnung	Description	Description	Bestell-Nr. Ordering No. No, Référence	Menge Quantity Quantité
1	Verdampferhaube	Evaporator cover	Capot d'évaporateur	88-50-10-00142-00 from Jan.2013	1
	Isolierung Verd.deckel	Insulation evap. cover	Isolation dévap. gauche	88-50-25-00012-00	1
	Verschlussbolzen	Fixing bolt	Boulon	88-50-16-00007-00	10
	Haltescheibe	Locating washer	Rondelle de maintien	88-68-08-00006-00	10
2	Kondensatorhaube	Condenser cover	Capot de condenseur	88-50-10-00048-00	1
	Verschlussbolzen	Fixing bolt	Boulon	88-50-16-00007-00	4
	Haltescheibe	Locating washer	Rondelle de maintien	88-68-08-00006-00	4
3	Verdampfergehäuse	Evaporator frame	Chassis d'évaporateur	88-50-10-00162-00 from Jan.2013	1
	Elektromontageblech	Bracket (electr. Panel)	Panneau de montage (électr.)	88-50-47-00392-00	2
	Dichtung f. verdampfer 16x30x1950	Gasket for evaporator 16x30x1950	Joint pour évaporateur 16x30x1950	88-50-25-00038-00	2
	Dichtung f. verdampfer 25x44x1175mm	Gasket for evaporator 25x44x1175mm	Joint pour évaporateur 25x44x1175mm	88-50-41-00004-00	2
	Dichtung f. deckel	Gasket profil for cover	Joint pour capot	88-81-05-00006-00	6,7m
	Dichtplatte 110x299mm	Sealing plate 110x299mm	Joint plaque 110x299mm	88-50-41-00005-00	2
4	Doppelradialgebläse BÜRSTENLOS 13VDC	Double radial blower BRUSHLESS 13VDC	Ventilateur double radial SANS COLLECTEURS 13V	88-50-57-00030-00	4
	Steuerkabel	Wiring cable	Câble	88-50-31-00020-00	2
5	Untersatzdichtung	Blower gasket	Joint de ventilateur	88-64-04-00015-00	4
6	Gebläsehalter	Blower bracket	Support de ventilateur	88-68-10-00002-00	8
	Schraubplatte	Boltplate	Panneau à vis	88-61-03-00100-00	8
7	Stopfen	Blanking plug	Bouchon	88-50-25-00039-00	4
8	Kondensatorgehäuse	Condenser frame	Chassis de condenseur	88-50-10-00180-00	1
	Verschlussunterteil	Clip	Embase	88-50-16-00011-00	4
	Transportflasche	Lifting eye	Support pour transport	88-50-60-00013-00	2
9	Axiallüfter 12VDC Standard	Axial fan 12VDC Standard	Ventilateur axiale 12 VDC	88-64-02-00020-00	3
	Steuerkabel	Wiring cable	Câble	88-50-31-00046-00	1
10	Lüftergitter	Fan grid	Grille du ventilateur	88-64-04-00019-00	3
11	Lüfterblech für 3 Lüfter	Fan bracket for 3 fans	Support pour 3 ventilateurs	88-50-47-00393-00	1
	Dichtband 5x20	Sealing tape 5x20	bande d'étanchéité 5x20	88-50-25-00037-00	3,2m
	Halter für Kabelbinder	Mounts for fastening strip	Support pour fixation bande	88-50-64-00006-00	10

Kältetechnische Einzelteile
Components Cooling System
Composants frigorifiques

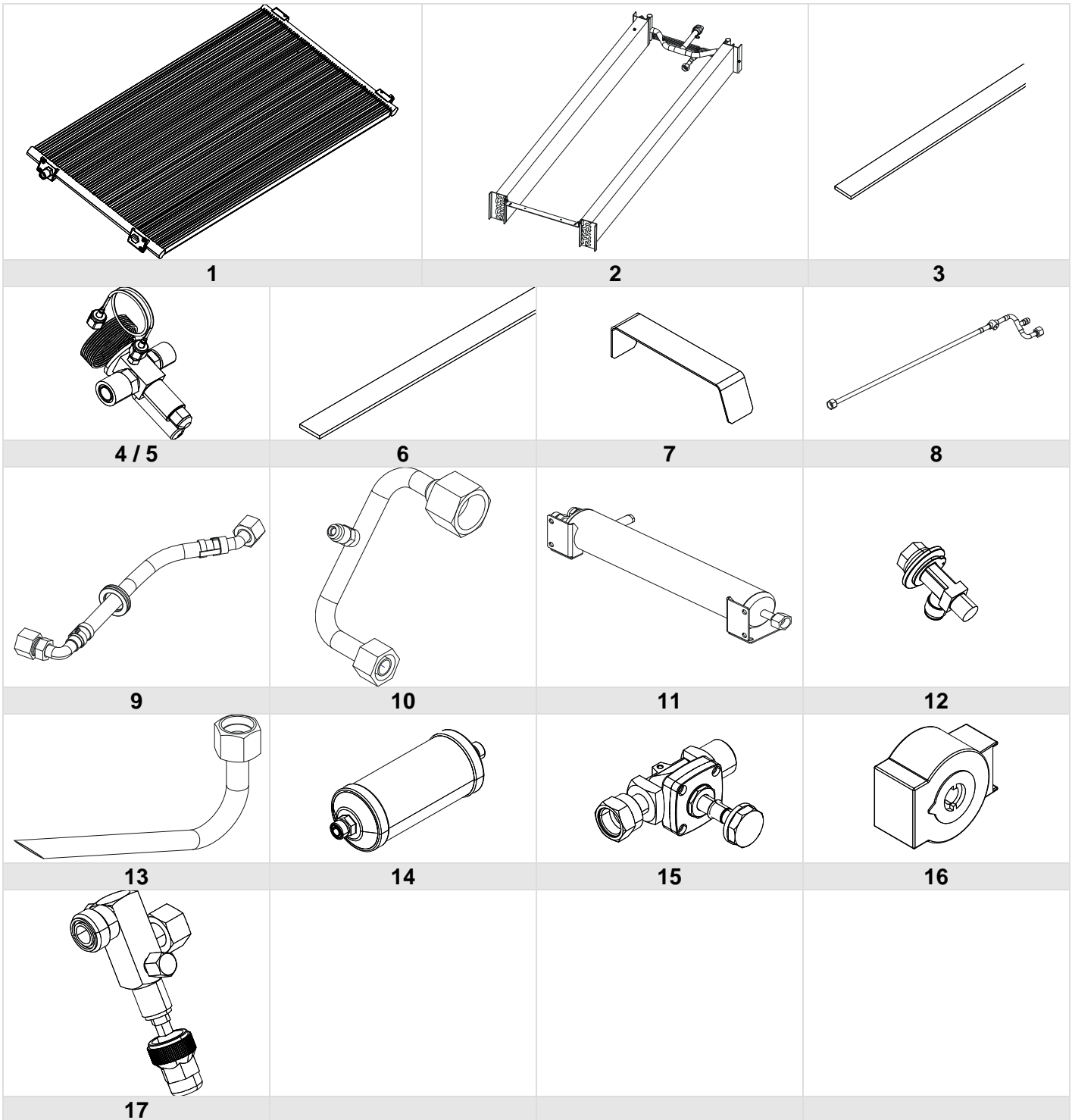



AC 353 I G4 Narrow 1-circuit 12VDC

Pos.	Bezeichnung	Description	Description	Bestell-Nr. Ordering No. No. Référence	Menge Quantity Quantité
1	Verflüssigerpaket	Condenser coil	Batterie de condenseur	88-62-05-00030-00	1
	Dichtband 5x20	Sealing tape 5x20	bande d'étanchéité 5x20	88-50-25-00037-00	3,0m
	Dichtband 10x30	Sealing tape 10x30	bande d'étanchéité 10x30	88-81-04-00003-00	0,5m
	Dichtband 30x30	Sealing tape 30x30	bande d'étanchéité 30x30	88-81-04-00004-00	1
	Dichtprofil (14x32)	Gasket profile (14x32)	Joint profil (14x32)	88-81-05-00002-00	0,8m
	Dichtprofil (14,5x21)	Gasket profile (14,5x21)	Joint profil (14,5x21)	88-50-46-00003-00	0,15m
	Dichtprofil (13,5x34)	Gasket profile (13,5x34)	Joint profil (13,5x34)	88-81-05-00003-00	1,55m
2	Verdampferpaket 3-reihig	Evaporator coil 3-row	Batterie d'évaporateur 3-row	88-50-23-00107-00	1
	Montageblech Verd. Vorne rechts	Mounting bracket evaporator coil - Front right	Panneau d'évap. devant droite	88-50-47-00235-00	1
	Montageblech Verd. Vorne links	Mounting bracket evaporator coil - Front left	Panneau d'évap. devant gauche	88-50-47-00236-00	1
	Montageblech Verd. Hinten rechts	Mounting bracket evaporator coil - Rear right	Panneau d'évap. avant droite	88-50-47-00237-00	1
	Montageblech Verd. Hinten links	Mounting bracket evaporator coil - Rear left	Panneau d'évap. avant gauche	88-50-47-00238-00	1
	Formdichtung front	Shaped gasket front	Joint en forme devant	88-50-25-00040-00	2
	Formdichtung heck rechts	Shaped gasket rear right	Joint en forme avant droite	88-50-25-00041-00	1
	Formdichtung heck links	Shaped gasket rear left	Joint en forme avant gauche	88-50-25-00042-00	1
	Rohrschelle	P Clip	Collier	88-50-33-00024-00	2
	Dichtband 6x12	Sealing tape 6x12	bande d'étanchéité 6x12	88-50-25-00025-00	3,6m
	Teerband Kork 3x50	Insulation cork tape 3x50	Matériau calorifugé 3x50	88-81-04-00001-00	3m
3	Isoliermatte Verd.paket	Insulation mat Evap. coil	Insulation d'évaporateur	88-50-25-00034-00	2
4	Expansionsventil R134a ORFS	Expansion valve R134a ORFS	Détendeur R134a ORFS	88-50-30-00006-00	2
	Dichtung ORFS 11/16"	Gasket ORFS 11/16"	Anneau ORFS 11/16"	88-63-07-00040-00	2
	Dichtung ORFS 13/16"	Gasket ORFS 13/16"	Anneau ORFS 13/16"	88-63-07-00001-00	2
5	Druckausgleichsleitung	Compensation line	Ligne de compensation	88-63-01-00001-00	2
	Dichtring 7/16"	Gasket ring 7/16"	Joint 7/16"	88-63-07-00002-00	4
6	BG Filter EU02	ASY Filter EU02	ASY Filtre EU02	88-35-04-00001-00	1
	Filter EU02	Filter EU02	Filtre EU02	88-50-02-00007-00	2
7	Filterhalter	Filter support	Support de filtre	88-50-73-00003-00	6
8	Flüssigkeitsleitung	Liquid line	Ligne de liquide	88-38-03-00001-00	1
	Dichtung ORFS 1"	Gasket ORFS 1"	Anneau ORFS 1"	88-63-07-00039-00	2
9	FL-Leitung (290 mm)	Liquid hose (290 mm)	Ligne Liquide (290 mm)	88-50-32-00200-00	1
	Dichtung ORFS 1"	Gasket ORFS 1"	Anneau ORFS 1"	88-63-07-00039-00	3
10	FI-Leitung mit Füllventil	Liquid line with filling valve	Ligne de tube	88-50-32-00241-00	1
	Dichtung ORFS 1"	Gasket ORFS 1"	Anneau ORFS 1"	88-63-07-00039-00	1
	Dichtring 3/4"	Gasket 3/4"	Joint 3/4"	88-63-07-00026-00	1
11	Sammelflasche	Receiver tank	Reservoir	88-50-12-00010-00	1
12	Sicherheitsventil	Protection valve	Soupapé de sûreté	88-62-07-00004-00	1
13	Rohrleitung für Sicherheitsventil	ASSY tube for Protection valve	ASSY tube pour Soupapé de sûreté	88-50-32-00242-00	1
	Gummitülle	Grommet	Douille	88-81-09-00002-00	1
14	Filtertrockner ORFS	Filter dryer ORFS	Déshydrateur ORFS	88-62-09-00001-00	2
	Dichtung ORFS 13/16"	Gasket ORFS 13/16"	Anneau ORFS 13/16"	88-63-07-00001-00	4
15	Magnetventil	Solenoid valve	Vanne magnétique	88-62-07-00002-00	2
16	Magnetspule 12VDC	Solenoid coil 12VDC	Bobine magnétique 12VDC	88-62-11-00023-00	2
17	Absperrventil (Ersetzt 14-00343-01)	Shut off valve (replaces 14-00343-01)	Vanne d'arrêt (replacé 14-00343-01)	88-62-07-00014-00	2

Elektrisches Bedienteil – Metallgehäuse

Electronic Climate Controller – metal housing

Régulateur de climat électronique – boîtier métallique

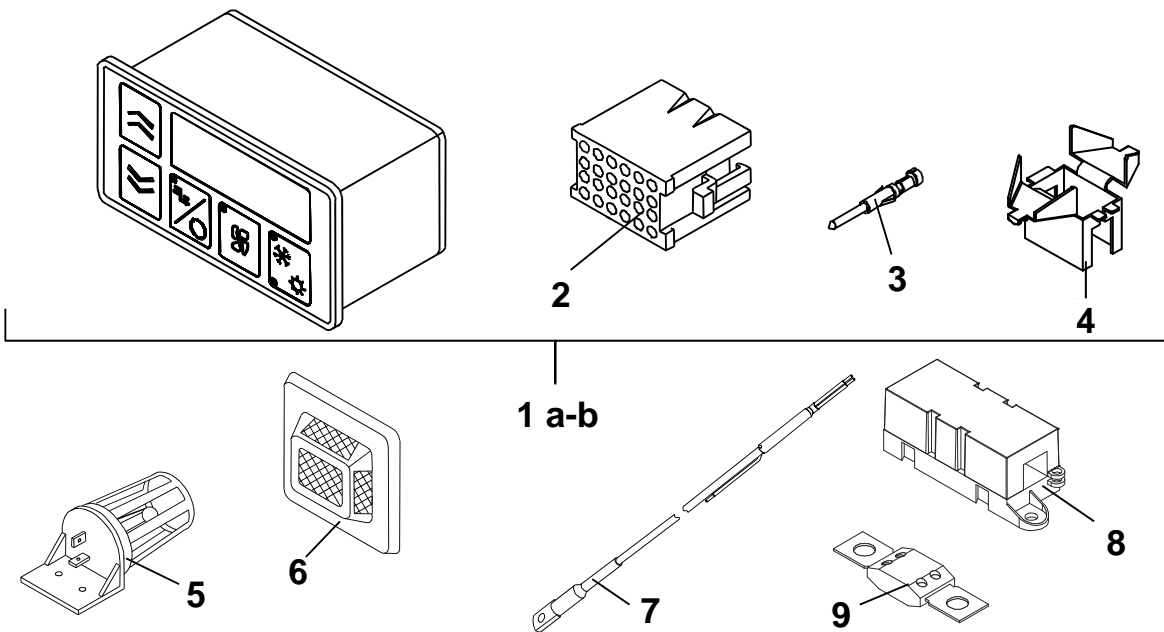

Pos.	Bezeichnung	Description	Description	Bestell-Nr. Ordering No. No, Référence
1a	BG Bedienteil Klimalogic I STANDARD	ASY Controller Klimalogic I STANDARD	ASY Regulateur Klimalogic I STANDARD	88-41-01-00029-00
1b	BG Bedienteil Klimalogic I SONDERAPPLIKATION	ASY Controller Klimalogic I Special APPLICATION	ASY Regulateur Klimalogic I Appl. spéciale	88-41-01-00053-00
2	Steckergehäuse 24pol	ITT plug 24 ts.	ITT connecteur 24bornes	88-83-11-00001-00
3	Stiftkontakt	Connector male	Contact de culot	88-83-12-00001-00
4	Zugentlastung	Strain relief	Maintien câble	88-83-13-00004-00
5	Fühler Innen	Sensor interior	Sonde interieur	88-83-06-00003-00
6	Fühler Innen	Sensor interior	Sonde interieur	88-83-06-00009-00
7	Fühler Außen	Sensor outside	Sonde exterieur	88-83-06-00002-00
8	Sicherungshalter Megafuse	Fuse socket Megafuse	Support á fusible Megafuse	88-83-27-00025-00
9	Sicherung 80A	Fuse 80A	Fusible 80A	88-83-27-00011-00
	Sicherung 100A	Fuse 100A	Fusible 100A	88-83-27-00022-00
	Sicherung 125A	Fuse 125A	Fusible 125A	88-83-27-00023-00
	Sicherung 150A	Fuse 150A	Fusible 150A	88-83-27-00024-00

Elektrisches Bedienteil – Kunststoffgehäuse
Electronic Climate Controller – plastic housing
Régulateur de climat électronique – boîtier plastique



Eberspächer

AC 353 I G4 Narrow
1-circuit 12VDC

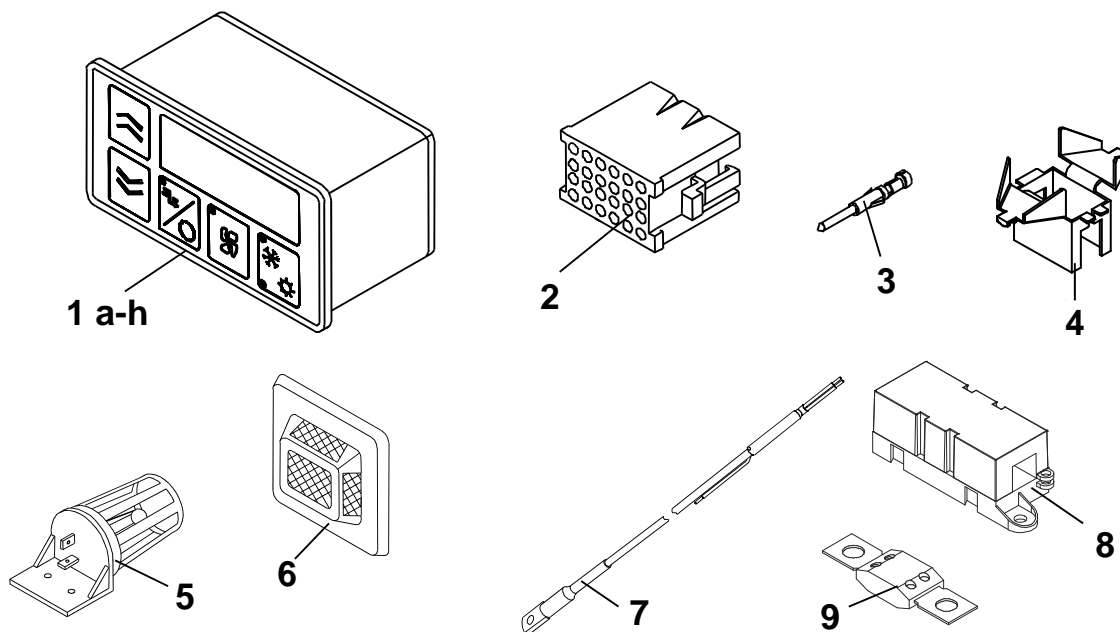

Pos.	Bezeichnung	Description	Description	Bestell-Nr. Ordering No. No, Référence
1a	BG Bedienteil KL-01 V1.11r6 PS007	ASSY Controller KL-01 V1.11r6 PS007	ASY Regulateur KL-01 V1.11r6 PS007	88-50-08-00003-00
1b	BG Bedienteil KL-01 V1.11r6 PS008	ASSY Controller KL-01 V1.11r6 PS008	ASY Regulateur KL-01 V1.11r6 PS008	88-50-08-00006-00
1c	BG Bedienteil KL-01 V1.11r6 PS009	ASSY Controller KL-01 V1.11r6 PS009	ASY Regulateur KL-01 V1.11r6 PS009	88-50-08-00007-00
1d	BG Bedienteil KL-01 V1.11r6 PS010	ASSY Controller KL-01 V1.11r6 PS010	ASY Regulateur KL-01 V1.11r6 PS010	88-50-08-00008-00
1e	BG Bedienteil KL-01 V1.11r6 PS012	ASSY Controller KL-01 V1.11r6 PS012	ASY Regulateur KL-01 V1.11r6 PS012	88-50-08-00010-00
1f	BG Bedienteil KL-01 V1.11r6 PS013	ASSY Controller KL-01 V1.11r6 PS013	ASY Regulateur KL-01 V1.11r6 PS013	88-50-08-00014-00
1g	BG Bedienteil KL-01 V1.11r6 PS014	ASSY Controller KL-01 V1.11r6 PS014	ASY Regulateur KL-01 V1.11r6 PS014	88-50-08-00023-00
1h	BG Bedienteil KL-01 V1.11r6 PS019	ASSY Controller KL-01 V1.11r6 PS019	ASY Regulateur KL-01 V1.11r6 PS019	88-50-08-00029-00
2	Steckergehäuse 24pol	ITT plug 24 ts.	ITT connecteur 24bornes	88-83-11-00001-00
3	Stiftkontakt	Connector male	Contact de culot	88-83-12-00001-00
4	Zugentlastung	Strain relief	Maintien câble	88-83-13-00004-00
5	Fühler Innen	Sensor interior	Sonde interieur	88-83-06-00003-00
6	Fühler Innen	Sensor interior	Sonde interieur	88-83-06-00009-00
7	Fühler Außen	Sensor outside	Sonde exterieur	88-83-06-00002-00
8	Sicherungshalter Megafuse	Fuse socket Megafuse	Support á fusible Megafuse	88-83-27-00025-00
9	Sicherung 80A	Fuse 80A	Fusible 80A	88-83-27-00011-00
	Sicherung 100A	Fuse 100A	Fusible 100A	88-83-27-00022-00
	Sicherung 125A	Fuse 125A	Fusible 125A	88-83-27-00023-00
	Sicherung 150A	Fuse 150A	Fusible 150A	88-83-27-00024-00

Elektrische Steuerungsteile

Electric Control Parts

Composants électrique

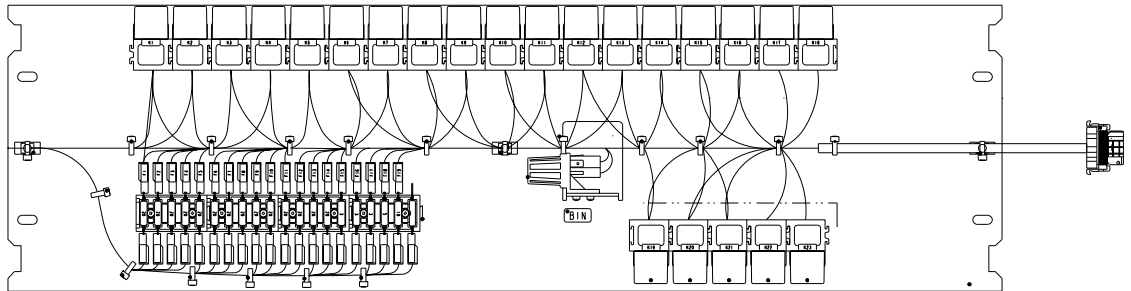

1



2



3 a / b

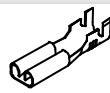

4

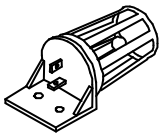

5

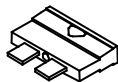

6 - 10

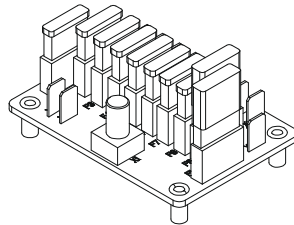

11



12

Pos.	Bezeichnung	Description	Description	Bestell-Nr. Ordering No. No, Référence
1	BG Elektro-Schalttafel Standard	ASY control panel Standard	ASY électrique platine Standard	88-50-36-00018-00
2	Relaissockel	Relay socket	Support de relais	88-83-24-00016-00
3a	Relais	Relay	Relais	88-83-24-00014-00
3b	Signalkonverter	Converter special	Convertisseur	88-83-23-00002-01
4	Flachsteckhülse	Female conector	Connecteur femelle	88-50-07-00077-00
5	Temperaturfühler Innen	Temperature sensor interior	Sonde de température interieur	88-83-06-00003-00
6	Flachsicherung 3A	Fuse 3A	Fusible 3A	88-83-27-00001-00
7	Flachsicherung 5A	Fuse 5A	Fusible 5A	88-83-27-00002-00
8	Flachsicherung 7,5A	Fuse 7,5A	Fusible 7,5A	88-83-27-00036-00
9	Flachsicherung 10A	Fuse 10A	Fusible 10A	88-83-27-00003-00
10	Flachsicherung 15A	Fuse 15A	Fusible 15A	88-83-27-00004-00
11	Flachsicherung 20A	Fuse 20A	Fusible 20A	88-83-27-00005-00
12	Flachsicherung 30A	Fuse 30A	Fusible 30A	88-50-20-00002-00
11	Sicherungsplatine	Fuse board	Tableau de fusible	88-50-20-00005-00
12	Sicherungsautomat 20A	Automatic fuse 20A	Automatic fusible 20A	88-83-27-00010-00
	Sicherungsautomat 15A	Automatic fuse 15A	Automatic fusible 15A	88-83-27-00014-00
	Sicherungsautomat 10A	Automatic fuse 10A	Automatic fusible 10A	88-83-03-00023-00
	Sicherungsautomat 5A	Automatic fuse 5A	Automatic fusible 5A	88-50-20-00004-00

Heizung (Optional)
Heating (Optional)
Chauffage (Optionale)

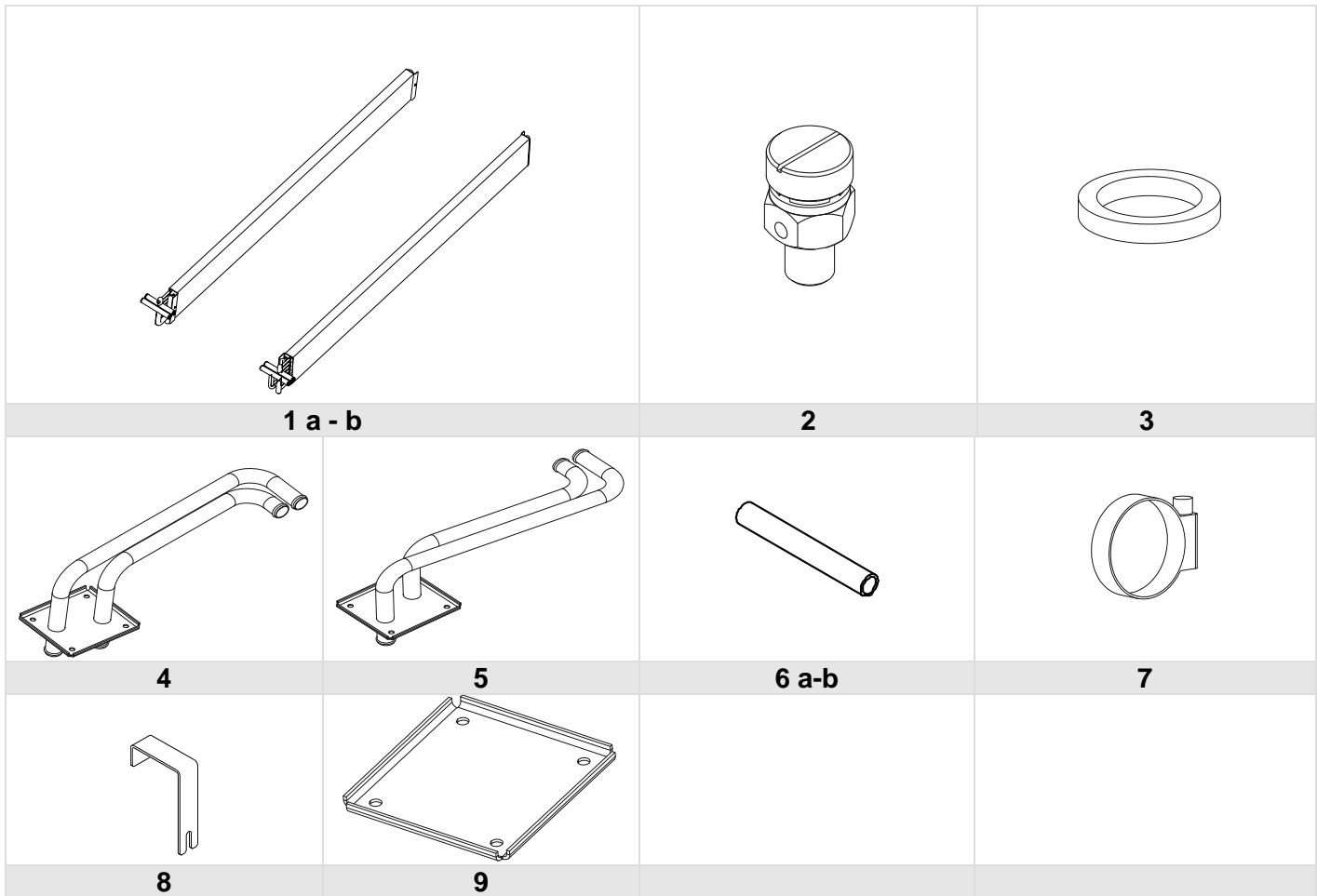

Pos.	Bezeichnung	Description	Description	Bestell-Nr. Ordering No. No, Référence	Menge Quantity Quantité
	BG Heizpaket li+re	ASSY heating coil le+ri	ASSY Batterie de chauffage ga+dr	88-50-29-00075-00	
1a	Heizpaket links	Heating coil left	Batterie de chauffage gauche	88-62-06-00003-00	1
1b	Heizpaket rechts	Heating coil right	Batterie de chauffage droite	88-62-06-00033-00	1
2	Entlüftungsventil	Bleeder valve	Soupape de purge	88-62-07-00005-00	1
3	Dichtring	Gasket	Joint	88-63-07-00052-00	2
4	Heiz-Adapter rechts	Heating adapter right	Adapteur de chauffage droite	88-50-32-00085-00	1
5	Heiz-Adapter links	Heating adapter left	Adapteur de chauffage gauche	88-50-32-00153-00	1
6a	Wasserschlauch 0,07m	Water hose 0,07m	Tuyau d'eau 0,07m	88-50-24-00008-00	2
6b	Wasserschlauch 0,65m	Water hose 0,65m	Tuyau d'eau 0,65m	88-50-24-00014-00	2
	Wasserschlauch	Water hose	Tuyau d'eau	88-81-06-00043-00	mtr
7	Schelle	Clip	Collier	88-50-33-00020-00	10
8	Klammer f. HZ-Paket	Clamp f. heater coil	Support de chauffage	88-50-47-00258-00	4
9	Abdeckblech	Blanking plate	Panneau de couverte	88-50-47-00110-00	1 / 2*

Frischlufklappen (Optional)

Fresh Air Flaps (Optional)

Volets d'air fraise (Optionale)

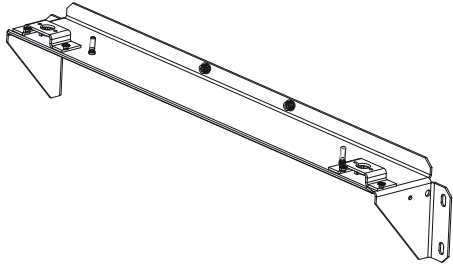

1

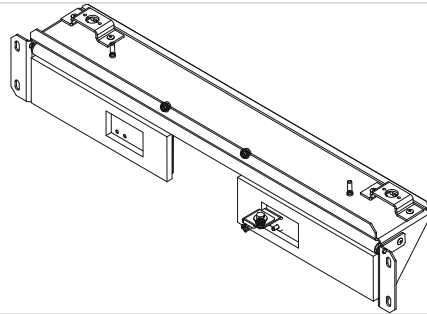

2

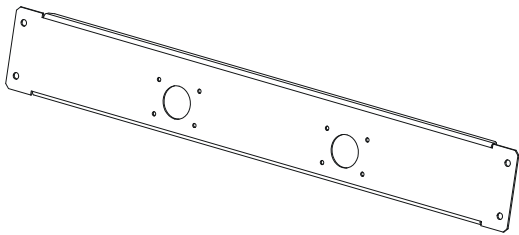

3

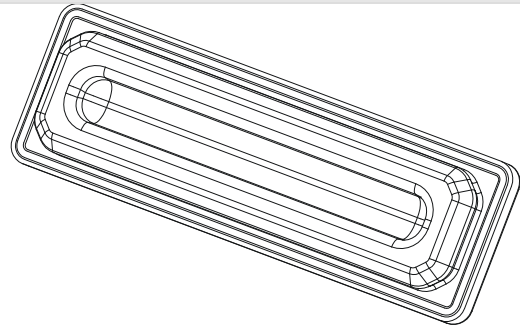

4

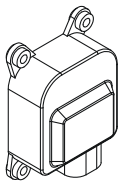

5

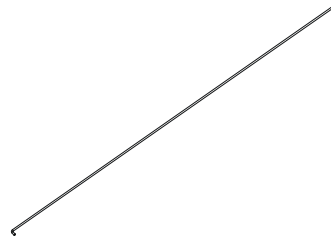

6

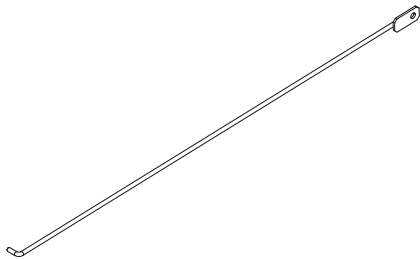

7



Eberspächer

AC 353 I G4 Narrow
1-circuit 12VDC

Pos.	Bezeichnung	Description	Description	Bestell-Nr. Ordering No. No, Référence	Menge Quantity Quantité
1	KIT ohne Frischluft	KIT w/o fresh air	KIT sans air frais	88-50-29-00104-00	1 / 2
2	BG Frischluftklappe Front	ASY Fresh air flap front	ASY Volet d'air frais devant	88-50-29-00105-00	1
3	Halter Abdeckung	Cover bracket	Courir	88-50-47-00112-00	1
4	Stopfen	Blanking plug	Bouchon	88-50-45-00020-00	2
5	Stellmotor	Servomotor	Moteur de commande	88-69-03-00005-00	1
	Halter für Stellmotor	Support bracket for servo motor	Support pour moteur servo	88-50-47-00257-00	1
	Gelenk für Stellmotor	Pivot bracket for servo motor	Pivot pour moteur servo	88-50-16-00010-00	2
6	Steuerkbel 980mm (vorne)	Operating wire 980mm (front)	Câble 980mm (avant)	88-50-47-00192-00	1
	Gummitülle	Grommet	Douille	88-50-22-00007-00	1
7	Steuerkbel 512mm (vorne)	Operating wire 512mm (front)	Câble 512mm (avant)	88-61-05-00004-00	1
	Kabelbinder	Cable clip	Collier de câbles	88-82-99-00005-00	3
	Dichtband 6x12	Sealing tape 6x12	bande d'étanchéité 6x12	88-50-25-00025-00	3,6m

Kältemittelanschlüsse
Refrigerant Connections
Connections frigorifique

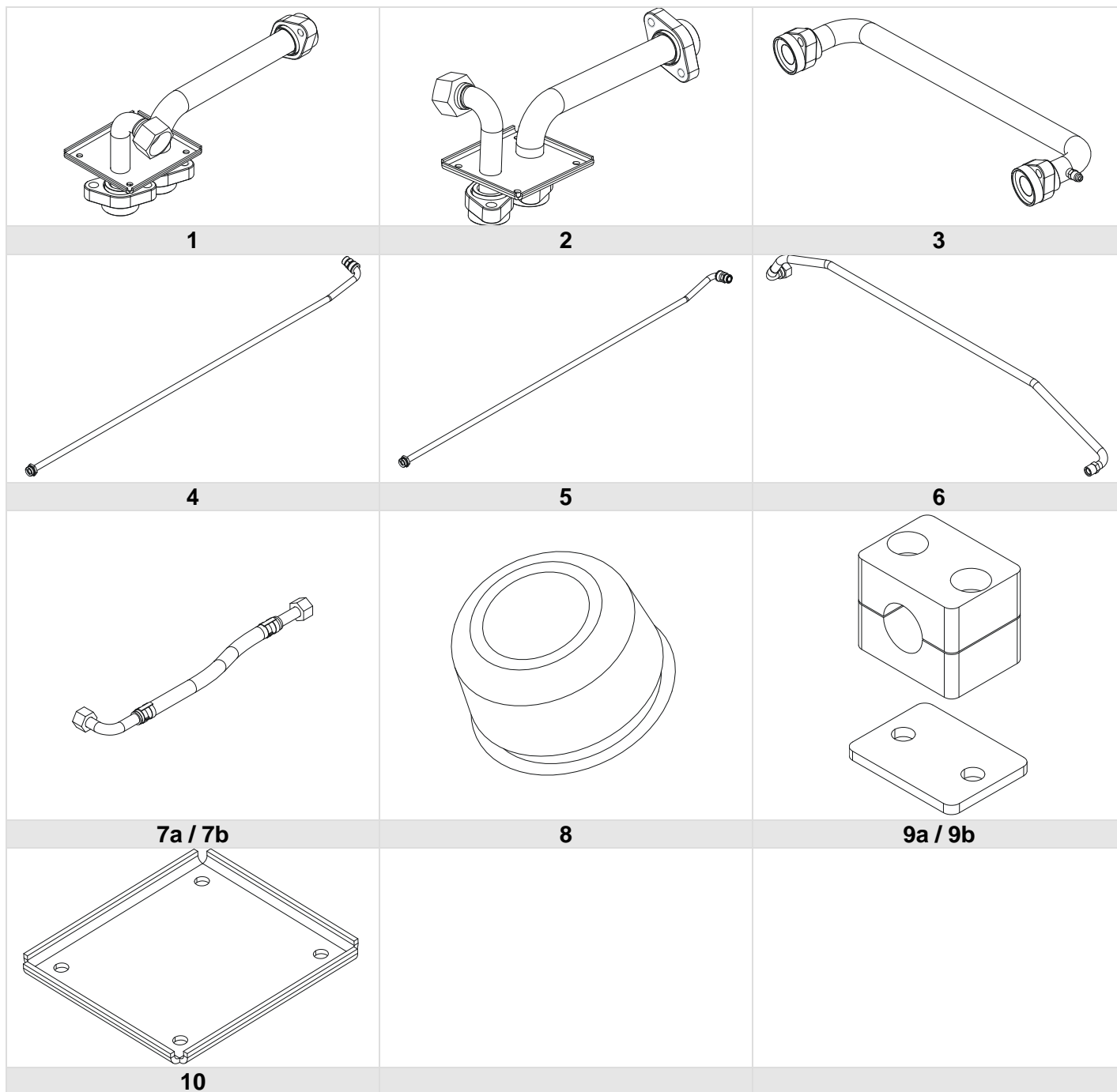



**AC 353 I G4 Narrow
1-circuit 12VDC**

Pos.	Bezeichnung	Description	Description	Bestell-Nr. Ordering No. No, Référence	Menge Quantity Quantité
1	BG Dachanschlüsse links	ASY Tube roof connect. Left	ASY Connections de toit gauche	88-50-32-00155-00	1
	O-Ring 1-5/16"	O ring 1-5/16"	Anneau O 1-5/16"	88-63-07-00042-00	1
	Dichtung für gehäuse	Gasket for frame	Joint d'étanchéité pour chasis	88-50-45-00043-00	2
2	BG Dachanschlüsse rechts	ASY Tube roof connect. right	ASY Connections de toit droite	88-50-32-00157-00	1
	O-Ring 1-5/16"	O ring 1-5/16"	Anneau O 1-5/16"	88-63-07-00042-00	1
	Dichtung für gehäuse	Gasket for frame	Joint d'étanchéité pour chasis	88-50-45-00043-00	2
3	KM-leitung	Refrigerant pipe	Tuyau de réfrigérant	88-50-32-00154-00	1
4	BG Druckleitung links D22mm	ASSY Pressure pipe left D22mm	ASSY Pipe d'aspiration gauche D22mm	88-50-32-00156-00	1
	Rohrschelle	P Clip	Collier	88-50-33-00025-00	2
5	BG Druckleitung rechts D22mm	ASSY Pressure pipe right D22mm	ASSY Pipe d'aspiration droite D22mm	88-50-32-00158-00	1
	Rohrschelle	P Clip	Collier	88-50-33-00025-00	2
6	BG Druckleitung rechts	ASSY Pressure pipe right	ASSY Pipe d'aspiration droite	88-50-32-00164-00	1
	Rohrschelle	P Clip	Collier	88-50-33-00025-00	2
7a	BG Druckleitung (90°; 0°) 538mm	ASSY discharge hose (90°; 0°) 538mm	ASSY Tuyaux d'aspiration (90°; 0°) 538mm	88-50-32-00162-00	1
	O-Ring 1-3/16"	O ring 1-3/16"	Anneau O 1-3/16"	88-63-07-00041-00	3
7b	BG Druckleitung (90°; 0°) 628mm	ASSY discharge hose (90°; 0°) 628mm	ASSY Tuyaux d'aspiration (90°; 0°) 628mm	88-50-29-00152-00	1
8	Gummitülle (Bohrung=38)	Sealing grommet (drill hole=38)	Douille (Percer un trou=38)	88-50-22-00004-00	3
	Gummitülle (Bohrung=48)	Sealing grommet (drill hole=48)	Douille (Percer un trou=48)	88-81-09-00001-00	1
9a	Schelle D22	Clamp D22	Collier D22	88-50-33-00028-00	1
	Schelle D16	Clamp D16	Collier D16	88-50-33-00023-00	4
	Schelle D18	Clamp D18	Collier D18	88-50-33-00022-00	2
9b	Deckplatte	Cover plate	Plaque	88-63-08-00014-00	6
10	Abdeckblech Alu	Bracket cover Alu	Support de couverture Alu	88-50-47-00203-00	1

Frontbox-Anschluss

Frontbox Connection

Connexion bloc de dégivrage

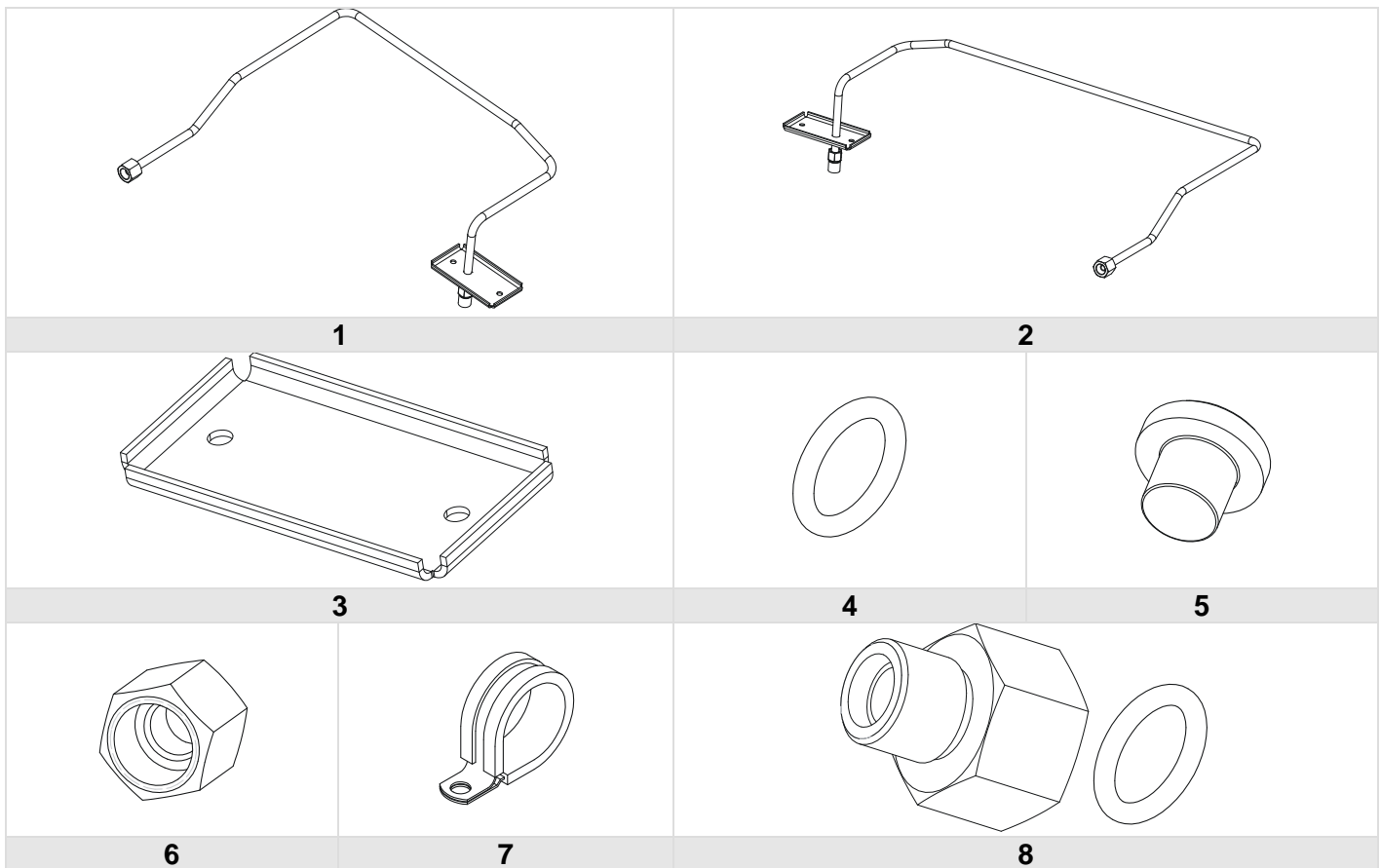

Pos.	Bezeichnung	Description	Description	Bestell-Nr. Ordering No. No, Référence	Menge Quantity Quantité
1	BG KM-leitung links (FrontBox)	ASSY Refrigerant pipe left (Frontbox connection)	ASSY Tuyaux d'réfrigérant gauche (Frontbox)	88-50-32-00084-00	1
2	BG KM-leitung links (FrontBox)	ASSY Refrigerant pipe left (Frontbox connection)	ASSY Tuyaux d'réfrigérant gauche (Frontbox)	88-50-32-00160-00	1
3	Abdeckblech	Blanking plate	Panneau de couverte	88-50-47-00109-00	1 / 2
4	Dichtring für 5/8"	Gasket for 5/8"	Joint four 5/8"	88-63-07-00021-00	2
5	Verschlussstopfen	Blanking Plug	Bouchon	88-50-05-00045-00	1
6	Überwurfmutter	Union nut	Écrou	88-63-09-00001-00	1
7	Rohrschelle	P Clip	Collier	88-50-33-00021-00	1
8	Reduzierung 5/8"-13/16"	Reduction 5/8"-13/16"	Réduction 5/8"-13/16"	88-50-05-00049-00	1
	Dichtring für 13/16"	Gasket for 13/16"	Joint four 13/16"	88-63-07-00001-00	1

Rückluftgitter
Return Air Grid
Grille d' air de retour



Eberspächer

AC 353 I G4 Narrow
1-circuit 12VDC

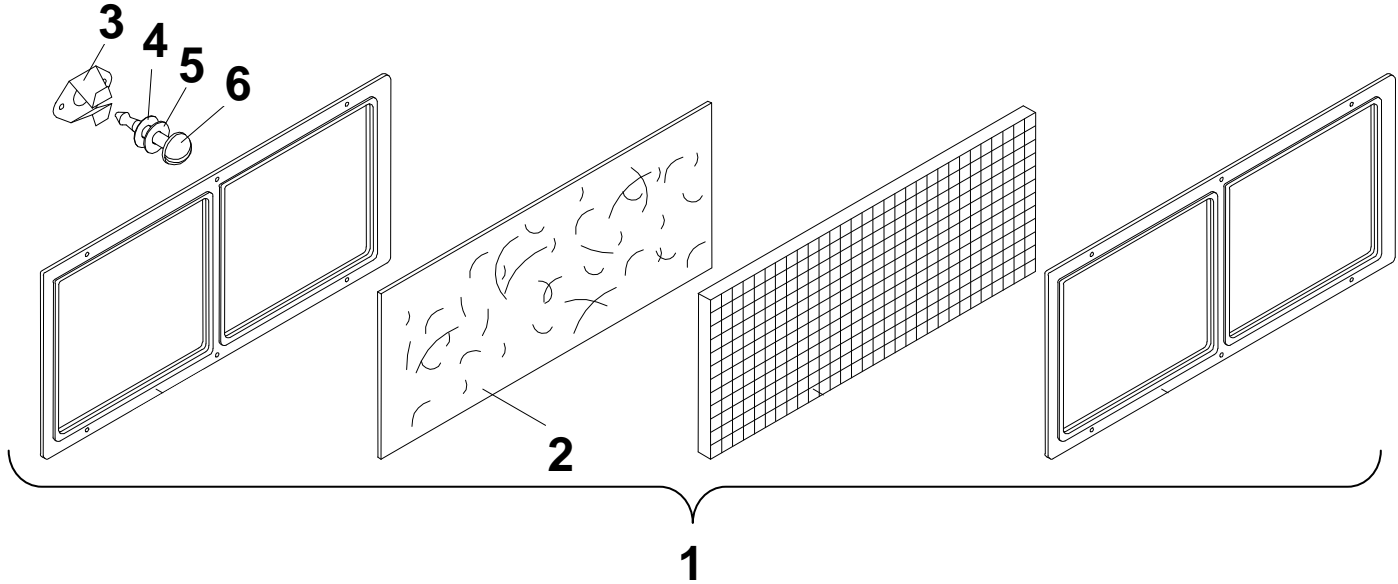

Pos.	Bezeichnung	Description	Description	Bestell-Nr. Ordering No. No.Référence	Menge Quantity Quantité
1	BG Rückluftgitter	ASSY Return air grid	ASSY Difusueur d'air	88-35-01-00001-00	1
2	Filtermatte	Filter mat	Filtre	88-81-08-00004-00	1
3	Klemmverschluss	Clamping catch	Fermeture de serrage	88-68-08-00009-00	6
4	Haltering Gummi	Rubber retaining ring	Rubber ring retaining	88-15-05-00002-00	6
5	Kopfunterlegscheibe	Head wearing gasket	Laveuse de tête	88-82-06-00019-00	6
6	Verschlussbolzen	Lock bolt	Boulon de fermeture	88-68-08-00012-00	6

Notizen

Notes

Notes

Notizen

Notes

Notes



Eberspächer

AC 353 I G4 Narrow
1-circuit 12VDC

Notizen

Notes

Notes

Eberspächer Sutrak GmbH & Co. KG
Heinkelstraße 5
71272 Renningen / Germany
Telefon: +49 7159 923-0
Fax: +49 7159 923-108
info.suetrak@eberspaecher.com
www.eberspaecher.com

