

ISOMETRIC VIEW

"SPACERS" BETWEEN ALTERNATOR AND ITEM# 1

- x2 9
- 10 4 1
- 8 9 10 8

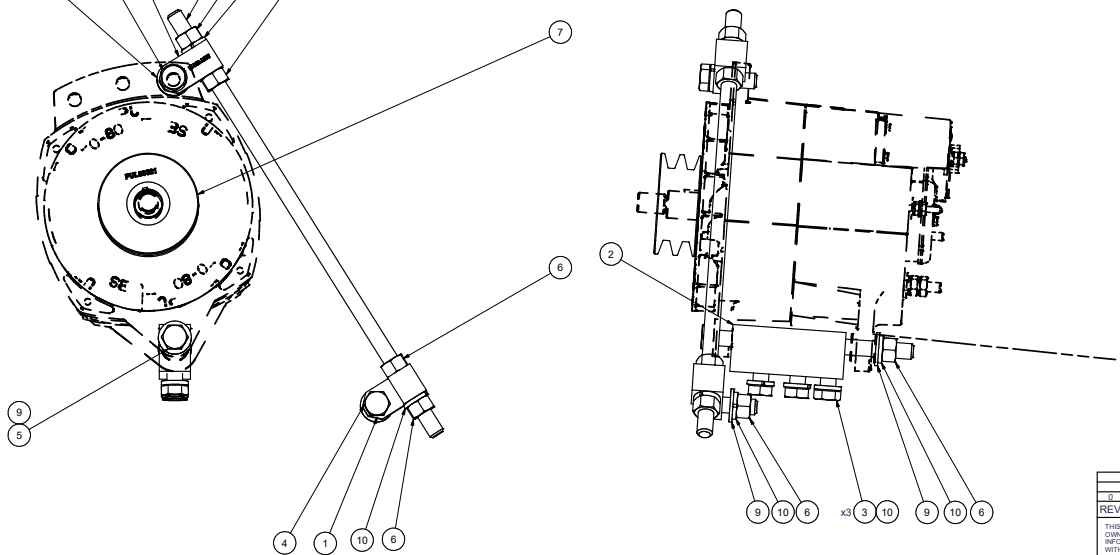

- 9 10 6
- x3 3 10 9 10 6

NOTES:
 1) USE SERVICABLE THREADLOCKER ON ALL FASTENERS TO ENGINE COMPONENTS AND TORQUE ALL BOLTS TO S.A.E. SPECIFICATIONS.
 2) SEE "TRANSARCTIC A/C COMPRESSOR MOUNT INSTALLATION DISCLAIMER".
 3) WEIGHT: 4.62 LBS.

ITEM	QTY	U/M	PART NUMBER	DESCRIPTION
10	8	EACH	IWLQ08000	WASHER, LOCK, 1/2", 8, PLT
9	5	EACH	WFC08000	WASHER, FLAT, 1/2", 8, PLT
8	1	EACH	TRD08150	THREADED ROD, 1/2-13UNC x 1.6", 5 PLT
7	1	EACH	PULO3321	PULLEY, ALT, IDLER, 3.25"ø, 2A
6	6	EACH	NTQ08000	NUT, HEX, 1/2-13UNC, 8, PLT
5	1	EACH	BTQ08653	BOLT, HEX, 1/2-13UNC x 6.50, 8, PLT
4	2	EACH	BTQ08150	BOLT, HEX, 1/2-13UNC x 1.50, 8, PLT
3	3	EACH	BTQ08100	BOLT, HEX, 1/2-13UNC x 1.00, 8, PLT
2	1	EACH	BM201082	BKT, ALT, BLOCK, 05G, TILT, '21
1	2	EACH	BMT10011	BKT, TENR, BLOCK, OFFSET, 3mm

BILL OF MATERIALS			
ITEM	QTY	U/M	DESCRIPTION
DRAWN: vjakowlew 11/5/2021			
CHECKED: Jose Rodriguez 11/5/2021			
OR: James Stewart 11/10/2011			
APPROVED: Dale Mason 11/5/2021			
MPG			
TITLE: ALT, KIT, BASE, 05G, TILT, '21			
SIZE: DWG NO			
D: KAC94131 REV 0			
DRAWING UNIT OF MEASURE: MM (INCH)		SCALE: 1:2	
SHEET 1		OF 1	

REV	ECN	DESCRIPTION	DATE	BY
0		RELEASED TO PRODUCTION	11/05/2021	VAL

UNSPECIFIED TOLERANCES: ALL DIMS IN INCHES
 ONE DECIMAL PLACE (X1) .125 FRACTIONAL, .0125
 TWO DECIMAL PLACE (X2) .005 FRACTIONAL, .005
 THREE DECIMAL PLACE (X3) .001 FRACTIONAL, .001
 FRACTIONAL: 1/16" MINIMUM

