

Bill of Materials Listing

TransArctic Canada Inc.

7/7/2017
Page 1 of 1

Product Number	Description	Date	Weight	Uof M	Yield
Line Component Prod#	Description	Bin Unit	Qty		
KMC84094	Mt Kit, ISL-D, HDX, 4xFC, Alt, '13-'16		9/6/2013	153.17	0
10	BEL32389		Belt, Banded B gr, 2388mm (94")	each	1
20	BMC83123		Bkt, Main, Idler, Weldm't, ISL, HDX, '13	each	1
30	BMC83125		Bkt, Weldm't, Adapter Pl, ISL, HDX, '13	each	1
40	BMC83129		Bkt, Weldm't, Main Base, ISL, HDX, '13	each	1
50	KCB84094		Kit, Comp, Alt, PS, 4xFC,'13	each	1
60	KPC89022		Kit, Pulley, ISL, 8.9L, 2B/X,'13	each	1
70	PUA05012		Pulley, Assy, Idler,B/BX gr,5", STL,Plt	each	1
80	PUL80074		Pulley, Idler, B/S, Wide, 76d (89102)	each	1
90	SCD21912		Spacer, Col, Drl,21.9mm x 25.4o x 12.3i	each	1
95	SCD25412		Spacer, Col, Drl,25.4mm x 25.4o x 12.3i	each	1
100	SLV17012		Sleeve, Pulley, 16.9o x 22.23mm x 12.32i	each	2
110	KBC84094		Bag Kit,Fasteners,KMC840/39/4194-9/62494	each	1

Bill of Materials Listing

TransArctic Canada Inc.

5/1/2017
Page 1 of 1

Product Number		Description	Bin	Date	Weight	Uof M	Yield
Line	Component Prod#	Description		Unit	Qty		
KBC84094		Bag Kit, Fasteners, KMC840/39/4194-9/62494		9/11/2013	2.32		0
10	BTC10045	Bolt, Hex, 10 x 1.5 x 45mm, 10.9, Plt, FT		each	3		
30	BTC12080	Bolt, Hex, 12 x 1.75 x 80mm, 10.9, Plt, FT		each	2		
40	BTQ06175	Bolt, Hex, 3/8-16unc, 1.75", 8, Plt		each	5		
50	BTQ08125	Bolt, Hex, 1/2-13unc, 1.25", 8, Plt		each	2		
60	BTQ08151	Bolt, Hex, 1/2-20unf, 1.5", 8, Plt		each	2		
70	CSF08101	Capscrew, FH, 1/2-20unf x 1.0", Alloy, Plt		each	4		
80	NTA10000	Nut, Hex, 10 x 1.5, 8.8, Plt		each	3		
90	NTA12000	Nut, Hex, 12 x 1.75, 8.8, Plt		each	2		
100	NTQ06000	Nut, Hex, 3/8-16unc, 8, Plt		each	5		
110	WFA10002	Washer, Flat, 10mm, Hvy, 8.8, Plt		each	6		
120	WFA12000	Washer, Flat, 12mm, 8.8, Plt		each	1		
125	WFA12002	Washer, Flat, 12mm, Hvy, 8.8, Plt		each	1		
130	WFS06002	Washer, Flat, 3/8", L9, Plt		each	10		
140	WFQ08000	Washer, Flat, 1/2", 8, Plt		each	4		
150	WLA10000	Washer, Lock, 10mm, 8.8, Plt		each	3		
160	WLA12000	Washer, Lock, 12mm, 8.8, Plt		each	2		
170	WLQ06000	Washer, Lock, 3/8", 8, Plt		each	5		
180	WLQ08000	Washer, Lock, 1/2", 8, Plt		each	4		

Bill of Materials Listing

TransArctic Canada Inc.

7/7/2017
Page 1 of 1

Product Number	Description	Date	Weight	Uof M	Yield
Line Component Prod#	Description	Bin Unit	Qty		
KCB84094	Kit, Comp, Alt, PS, 4xFC,'13		9/9/2013	62.57	0
10	BEL11040		Belt, A gr, 1040mm (41")	each	2
20	BMC83114		Bkt, PI, ALT Spacer, T3RE, '13	each	1
30	BMN80008		Vibration Isolator, Bar,16.50 x 2 x 1.50	each	2
40	BMN80025		Bkt, Back, PL, Slide, IC, RE300	each	1
50	BMT10011		Bkt, Tenr, Block, Offset, 3mm	each	2
60	BMZ00043		Bkt, Main, Base PI, '13	each	1
70	KBT84094		Kit, Platform, PS, 4xFC, W/Alt,'13	each	1
80	PUL03321		Pulley, ALT, Idler, 3.25"d, 2A	each	1
90	TRD08120		Threaded, Rod, 1/2-13unc x 12", 5, Plt	each	1
100	KBZ84094		Bag Kit, Fasteners, KCB84094	each	1

Bill of Materials Listing

TransArctic Canada Inc.

2/4/2015
Page 1 of 1

Product Number	Description	Date	Weight	Uof M	Yield
Line Component Prod#	Description	Bin Unit	Qty		
KBZ84094	Bag Kit, Fasteners, KCB84094	10/18/2013	2.42		0
10	BTP08653				
	Bolt, Hex, 1/2-13unc, 6.5", 5, Plt, FT	each	1		
20	BTQ08101				
	Bolt, Hex, 1/2-20unf, 1.00", 8, Plt	each	4		
30	BTQ08150				
	Bolt, Hex, 1/2-13unc, 1.5", 8, Plt	each	4		
40	BTQ08653				
	Bolt, Hex, 1/2-13unc, 6.5", 8, Plt	each	1		
50	CSF08076				
	Capscrew, FH, 1/2-20unf x .75", Alloy, Plt	each	2		
60	NTQ08000				
	Nut, Hex, 1/2-13unc, 8, Plt	each	7		
70	WFQ08000				
	Washer, Flat, 1/2", 8, Plt	each	10		
80	WLQ08000				
	Washer, Lock, 1/2", 8, Plt	each	12		

Bill of Materials Listing

TransArctic Canada Inc.

7/7/2017
Page 1 of 1

Product Number	Description	Date	Weight	Uof M	Yield
Line Component Prod#	Description	Bin Unit	Qty		
KBT84094	Kit, Platform, PS, 4xFC, W/Alt,'13		9/9/2013	18.59	0
10	BMC83131		Bkt, Weldm't, 4xFC W/ Alt, P-S, HDX, '13	each	1
20	BMN80031		Bkt, Main, Slide, Assy, 05K, IC, RE300	each	1
30	KBZ00010		Bag Kit, Fasteners, KBT84094/83990	each	1

Bill of Materials Listing

TransArctic Canada Inc.

2/4/2015
Page 1 of 1

Product Number	Description	Date	Weight	Uof M	Yield
Line Component Prod#	Description	Bin Unit	Qty		
KBZ00010	Bag Kit, Fasteners, KBT84094/83990		11/6/2013	1.23	0
10	BTC12040		Bolt, Hex, 12 x 1.75 x 40mm, 10.9,Plt,FT	each	4
15	BTC12060		Bolt, Hex, 12 x 1.75 x 60mm, 10.9,Plt,FT	each	4
20	NTP07000		Nut, Hex, 7/16-14unc, 5, Plt	each	4
30	WFA12000		Washer, Flat, 12mm, 8.8, Plt	each	8
40	WFN07000		Washer, Flat, 7/16", 2, Plt	each	4
50	WLA12000		Washer, Lock, 12mm, 8.8, Plt	each	4
60	WLP07000		Washer, Lock, 7/16", 5, Plt	each	4

Bill of Materials Listing

TransArctic Canada Inc.

2/4/2015
Page 1 of 1

Product Number	Description	Date	Weight	Uof M	Yield
Line Component Prod#	Description	Bin Unit	Qty		
KPC89022	Kit, Pulley, ISL, 8.9L, 2B/X,'13		10/15/2013	11.51	0
10	PUL89022		Pulley, Crank, ISL, 8.9L, 2B/X, 8", '13	each	1
20	BTC10050		Bolt, Hex, 10 x 1.5 x 50mm, 10.9, Plt	each	5
30	WFA10000		Washer, Flat, 10mm, 8.8, Plt	each	5

8 7 6 5 4 3 2 1

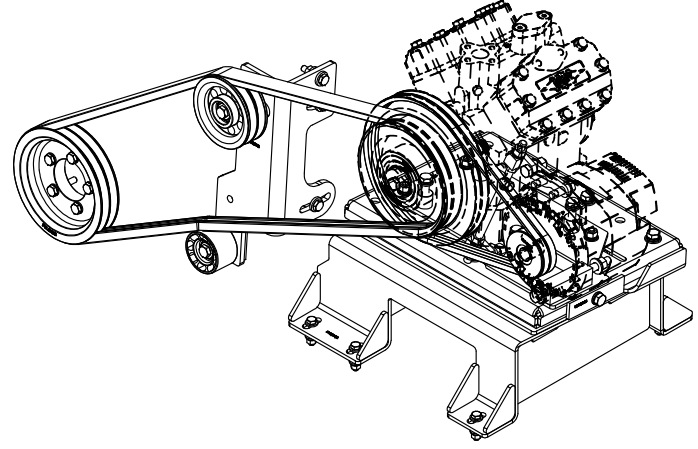
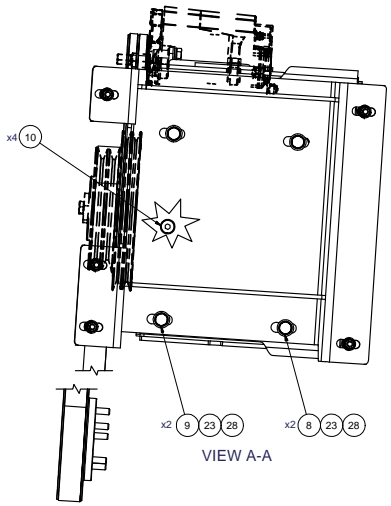
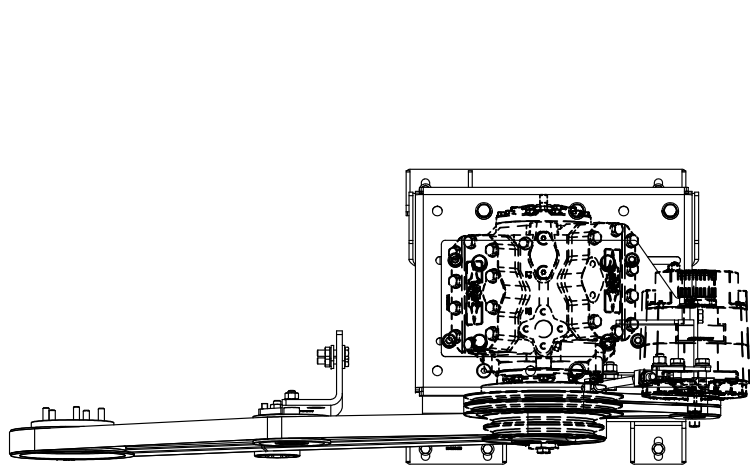

ISOMETRIC VIEW

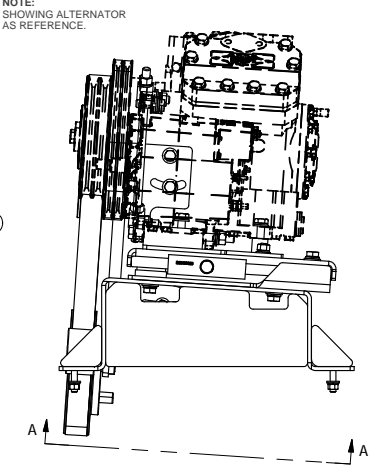
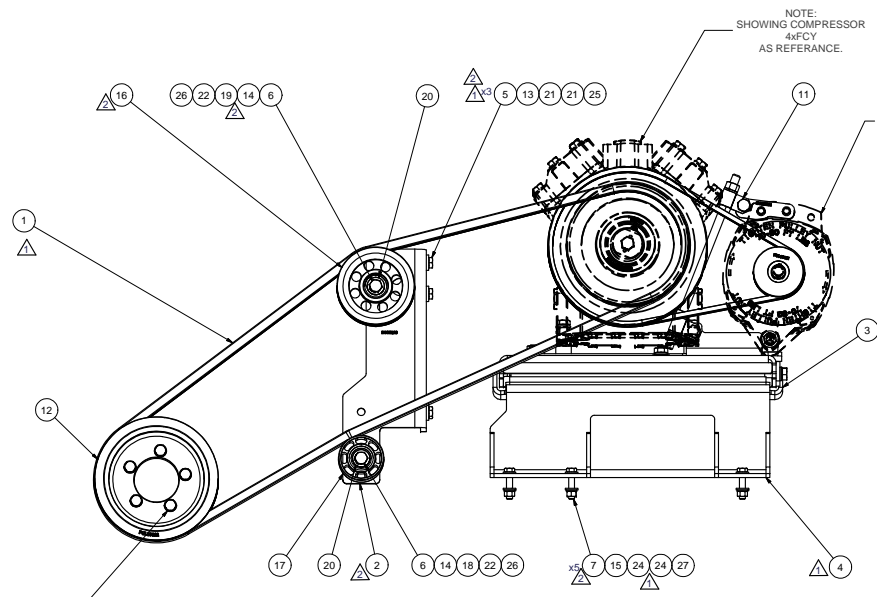

NOTE:
SHOWING COMPRESSOR
4xFCY
AS REFERENCE.

NOTE:
SHOWING ALTERNATOR
AS REFERENCE.

NOTES:

- 1) USE SERVICABLE THREADLOCKER ON ALL FASTENERS TO ENGINE COMPONENTS AND TORQUE ALL BOLTS TO S.A.E. SPECIFICATIONS.
- 2) SEE "TRANSARGTIC A/C COMPRESSOR MOUNT INSTALLATION DISCLAIMER".

ITEM	QTY	U/M	PART NUMBER	DESCRIPTION
26	4	EACH	WL008000	WASHER, LOCK, 1/2", 8, PLT
27	5	EACH	WL006000	WASHER, LOCK, 3/8", 8, PLT
26	2	EACH	WL120000	WASHER, LOCK, 12mm, 8.8, PLT
25	3	EACH	WL100000	WASHER, LOCK, 10mm, 8.8, PLT
24	10	EACH	WFS06002	WASHER, FLAT, 3/8", L9, PLT
23	4	EACH	WFO08000	WASHER, FLAT, 1/2", 8, PLT
22	2	EACH	WFA12000	WASHER, FLAT, 12mm, 8.8, PLT
21	6	EACH	WFA10002	WASHER, FLAT, 10mm, HWY, 8.8, PLT
20	2	EACH	SLV17012	SLEEVE, PULLEY, 16.90 x 22.23 mm x12.19l
19	1	EACH	SCD25412	SPACER, COL, DRL, 25.4mm x 25.40 x 12.3l
18	1	EACH	SCD21912	SPACER, COL, DRL, 21.9mm x 31.80 x12.3l
17	1	EACH	PUL80074	PULLEY, IDLER, BACKSIDE, P8, 74D, 46.27W
16	1	EACH	PIU05012	PULLEY, ASSY, IDLER, B/BX gr, 5" STL, PLT
15	5	EACH	NT006000	NUT, HEX, 3/8-16UNC, 8, PLT
14	2	EACH	NTA12000	NUT, HEX, 12 x 1.75, 8.8, PLT
13	3	EACH	NTA10000	NUT, HEX, 10 x 1.5, 8.8, PLT
12	1	EACH	KPC89022	KIT, PULLEY, ISL, 8.9L, 2B/X, '13
11	1	EACH	KCB84094	KIT, COMPRESSOR, 2AV, PS, 4xFC, '13
10	4	EACH	CSF08101	CAPSCREW, FH, 1/2-20UNF x 1", ALLOY, PLT
9	2	EACH	BTQ08151	BOLT, HEX, 1/2-20UNF x 1.50, 8, PLT
8	2	EACH	BTQ08125	BOLT, HEX, 1/2-13UNC x 1.25, 8, PLT
7	5	EACH	BTQ06175	BOLT, HEX, 3/8-16UNC, 1.75", 8, PLT
6	2	EACH	BTC12080	BOLT, HEX, 12 x 1.75 x 80mm, 10.9, PLT
5	3	EACH	BTC10045	BOLT, HEX, 10 x 1.5 x 45mm, 10.9, PLT
4	1	EACH	BMC83129	BKT, WELDMT, MAIN BASE, ISL, HDX, '13
3	1	EACH	BMC83125	BKT, WELDMT, ADAPTER PL, ISL, HDX, '13
2	1	EACH	BMC83123	BKT, MAIN, IDLER, WELDMT, ISL, HDX, '13
1	1	EACH	BEL32388	BELT, BANDED B gr, 2388mm (9'4")

BILL OF MATERIALS

DRAWN	J Rodriguez	9/11/2013
CHECKED		
RELEASED TO PRODUCTION	Vaj Jakovlew	9/11/2013
DATE:	DATE:	DATE:
BY:	BY:	BY:
APPROVED	Ron Ingram	9/11/2013
DATE	Date Mason	9/11/2013

TRANSARGTIC INC.

MT KIT, ISL-D, HDX, 4xFC, ALT, '13-'16

SIZE: D DWG NO: KMC84094 REV: 2

SCALE: 1:4 SHEET 1 OF 1

NOTE:
TORQUE TO: 48 FT-LB PLAIN & LUBRICATED W/ CLEAN ENGINE OIL (15W-40)
(HEXBOLT CAPSCREW M10 x 1.5 x 50mm)
TIGHTEN IN TWO STEPS IN A CRIS-CROSS TIGHTENING SEQUENCE PATTERN.

UNSPECIFIED TOLERANCES:	PLT	ALL
ONE DECIMAL PLACE (X.0)	0.005	0.005
TWO DECIMAL PLACE (X.00)	0.002	0.002
THREE DECIMAL PLACE (X.000)	0.001	0.001
FRACTIONAL (1/16")	0.001	0.001



DRAWING UNIT OF MEASURE: MM (INCH)

8 7 6 5 4 3 2 1

TOP VIEW

PARTS REMOVED FOR CLARITY.

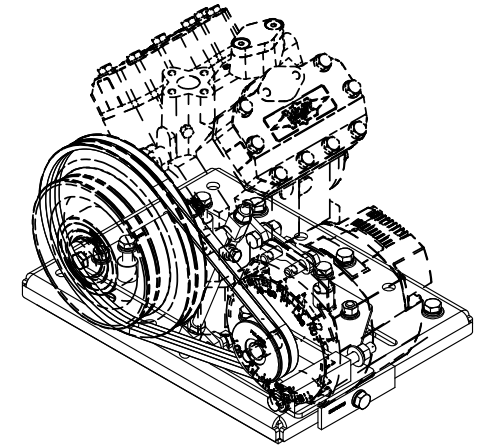
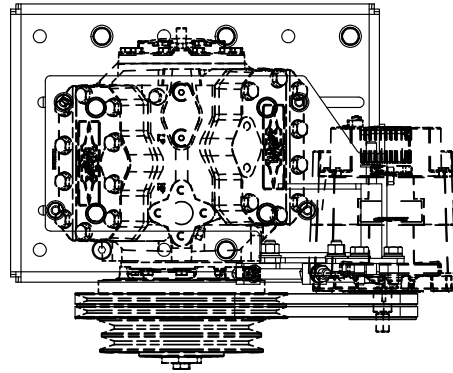
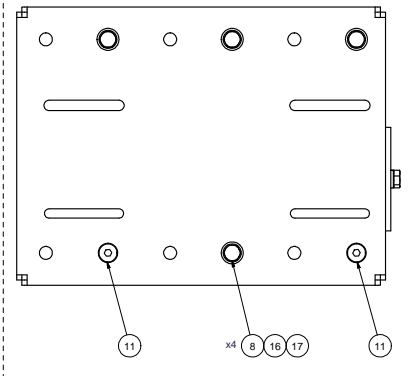

ISOMETRIC VIEW

NOTE:
SHOWING COMPRESSOR
4xFCY
AS REFERENCE.

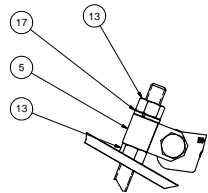
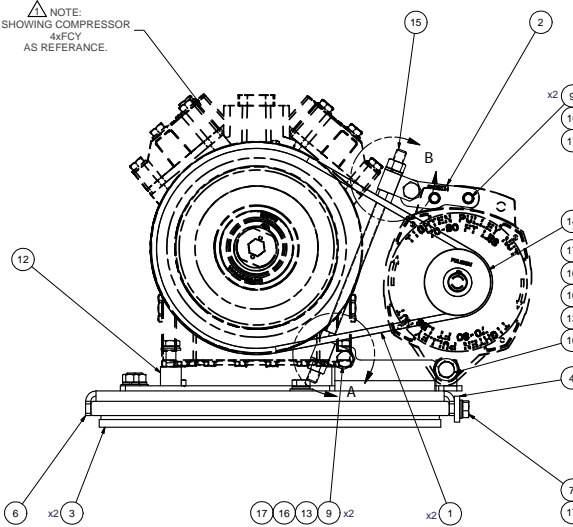

DETAIL B
SCALE 1/2

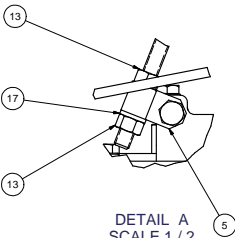

DETAIL A
SCALE 1/2

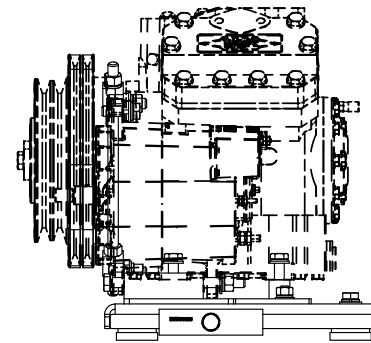

NOTES:

- 1) USE SERVICABLE THREADLOCKER ON ALL FASTENERS TO ENGINE COMPONENTS AND TORQUE ALL BOLTS TO S.A.E. SPECIFICATIONS.
- 2) SEE 'TRANSARCTIC A/C COMPRESSOR MOUNT INSTALLATION DISCLAIMER'.
- 3) WEIGHT: 56.70 LBS.

ITEM	QTY	U/M	PART NUMBER	DESCRIPTION
17	12	EACH	WLO08000	WASHER, LOCK, 1/2", 8, PLT
16	10	EACH	WFO08000	WASHER, FLAT, 1/2", 8, PLT
15	1	EACH	TRD08120	THREADED, ROD, 1/2-13UNC x 12", 5 PLT
14	1	EACH	PUL03321	PULLEY, ALT, IDLER, 3.25"o, 2A
13	7	EACH	NT008000	NUT, HEX, 1/2-13UNC, 8, PLT
12	1	EACH	K8184094	KIT, PLATFORM, PS, 4xFCY/ FK40, W/ ALT, '13
11	2	EACH	CSF00076	CAPSCREW, FH, 1/2-20UNF x .75", ALLOY, PLT
10	1	EACH	BT008653	BOLT, HEX, 1/2-13UNC x 6.50, 8, PLT
9	4	EACH	BT008150	BOLT, HEX, 1/2-13UNC x 1.50, 8, PLT
8	4	EACH	BT008101	BOLT, HEX, 1/2-20UNF x 1.00, 5, PLT, FT
7	1	EACH	BT008653	BOLT, HEX, 1/2-13UNC x 6.50, 5, PLT, FT
6	1	EACH	BMZ00043	BKT, MAIN, BASE PL, '13
5	2	EACH	BMT10011	BKT, TENR, BLOCK, OFFSET, 3mm
4	1	EACH	BMN80025	BKT, BACK, PL, SLIDE, IC, RE300
3	2	EACH	BMN80008	VIBRATION ISOLATOR, BAR, 16.50 x 2 x 1.50
2	1	EACH	BMK83114	BKT, PL, ALT, SPACER, T3RE, '13
1	2	EACH	BELT1040	BELT, A, gr, 1040mm (41") (17410)

BILL OF MATERIALS

BROWN	9/9/2013		
JRodriguez			
CHECKED			
VJal_Jakowlew	9/9/2013		
GA			
JJames Stewart	9/9/2013		
BY			
Ron Ingram	9/9/2013		
APPROVED			
Dale Mason	9/9/2013		

TRANSARCTIC INC.

TITLE: KIT, COMPRESSOR, ALT, PS, 4xFC, '13

SIZE: D DWG NO: KCB84094 REV: 1

SCALE: 1:3 SHEET 1 OF 1

1	REVISED NOTE & TITLE	6/26/2017	JRR
0	RELEASED TO PRODUCTION	9/9/2013	JRR
REV	DESCRIPTION	DATE	BY
			JJames Stewart
			Ron Ingram
			Dale Mason

THIS DRAWING CONTAINS PROPRIETARY CONFIDENTIAL INFORMATION OWNED BY TRANSARCTIC CANADA INC. THE DOCUMENT AND THE INFORMATION IT IS NOT TO BE USED, DISCLOSED OR REPRODUCED WITHOUT EXPRESS WRITTEN PERMISSION OF THE COMPANY.

UNSPECIFIED TOLERANCES: ALL DIMS ±.005
 ONE DECIMAL PLACE (.X) ±.010
 TWO DECIMAL PLACE (.XX) ±.005
 THREE DECIMAL PLACE (.XXX) ±.002
 FRACTIONAL (1/16") ±.005

THIRD ANGLE PROJECTION

DRAWING UNIT OF MEASURE: MM (INCH)

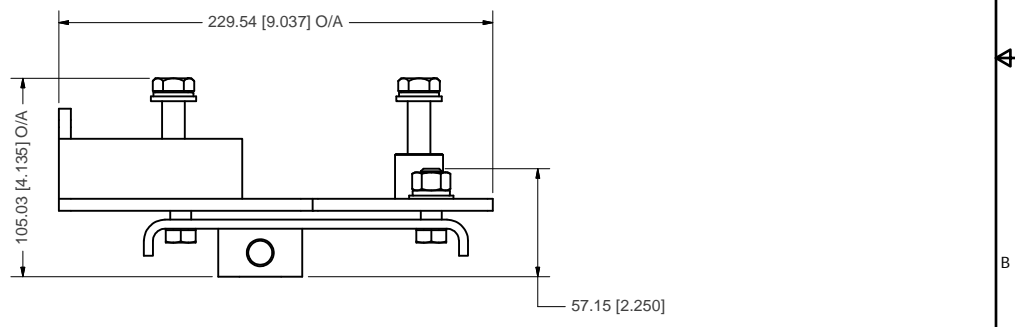
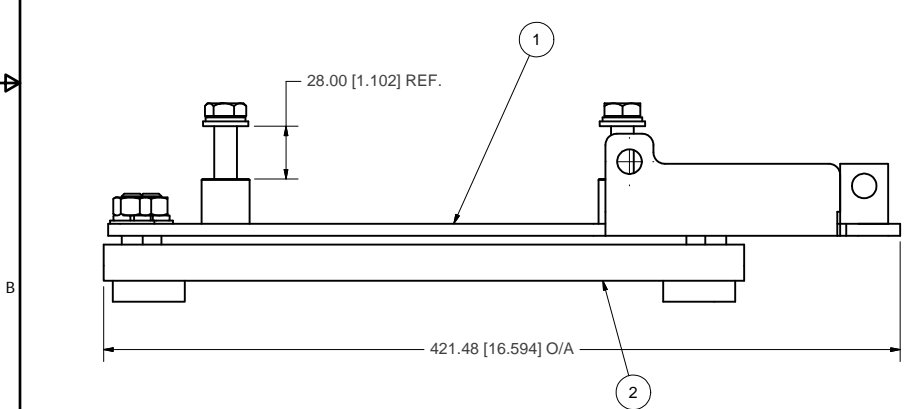
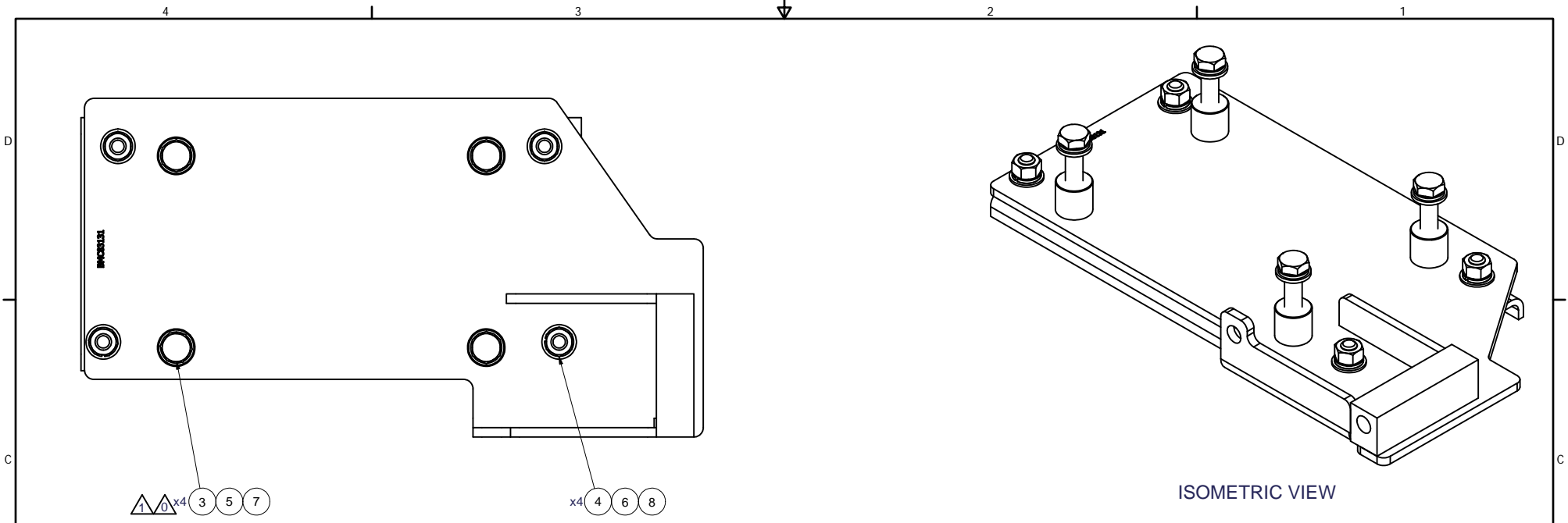

- NOTES:**
- 1) USE SERVICABLE THREADLOCKER ON ALL FASTENERS TO ENGINE COMPONENTS AND TORQUE **ALL** BOLTS TO S.A.E. SPECIFICATIONS.
 - 2) SEE "TRANSARCTIC A/C COMPRESSOR MOUNT INSTALLATION DISCLAIMER".
 - 3) WEIGHT: 18.22 LBS.

1	-	REMOVED 4x BTC12060/40 BOLTS.	6/28/2017	JRR
0	-	ADDED 4x BTC12040 BOLTS.	6/5/2014	JRR
A	-	RELEASED TO PROTOTYPE.	9/5/2013	JRR
REV/ECN:	DESCRIPTION:	DATE:	BY:	
			James Stewart	
THIS DRAWING CONTAINS PROPRIETARY CONFIDENTIAL INFORMATION OWNED BY TRANSARCTIC CANADA INC.. THE DOCUMENT AND THE INFORMATION IN IT ARE NOT TO BE USED, DISCLOSED OR REPRODUCED WITHOUT EXPRESS WRITTEN PERMISSION OF THE COMPANY.				
UNSPECIFIED TOLERANCES:		[ALT. DIM.]		
ONE DECIMAL PLACE (.X)	.50	[.020]		
TWO DECIMAL PLACE (.XX)	.25	[.010]		
THREE DECIMAL PLACE (.XXX)	.10	[.005]		
FRACTIONAL +/- .002"	ANGULAR +/- .50°	THIRD ANGLE PROJECTION		

8	4	EACH	WLP07000	WASHER, LOCK, 7/16", 5, PLT
7	4	EACH	WLA12000	WASHER, LOCK, 12mm, 8.8, PLT
6	4	EACH	WFN07000	WASHER, FLAT, 7/16", 2, PLT
5	4	EACH	WFA12000	WASHER, FLAT, 12mm, 8.8, PLT
4	4	EACH	NTP07000	NUT, HEX, 7/16-14UNC, 5, PLT
3	4	EACH	BTC12050	BOLT, HEX, 12 x 1.75 x 50mm, 10.9, PLT
2	1	EACH	BMN80031	BKT, MAIN, SLIDE, ASSY, 05K, IC, RE300
1	1	EACH	BMC83131	BKT, WELDM'T, 4xFCY W/ALT, P-S, HDX, '13
ITEM	QTY	U/M	PART NUMBER	DESCRIPTION

BILL OF MATERIALS
TRANSARCTIC INC.

DRAWN	jrodriguez	9/5/2013	TITLE
CHECKED	Val Jakowlew	9/5/2013	
APPROVED	Dale Mason	9/5/2013	
MFG	Ron Ingram	9/5/2013	
KIT, PLATFORM, PS, 4xFCY, W/ ALT, '13			REV 1
SIZE	C	DWG NO KBT84094	
DRAWING UNIT OF MEASURE:	MM [INCH]	SCALE	1:2
SHEET			1 OF 1

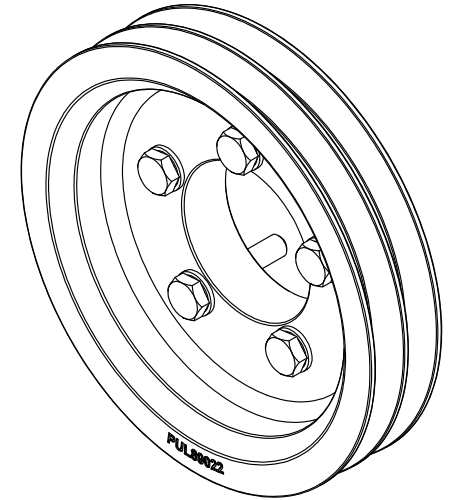
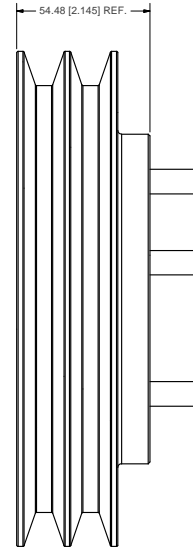
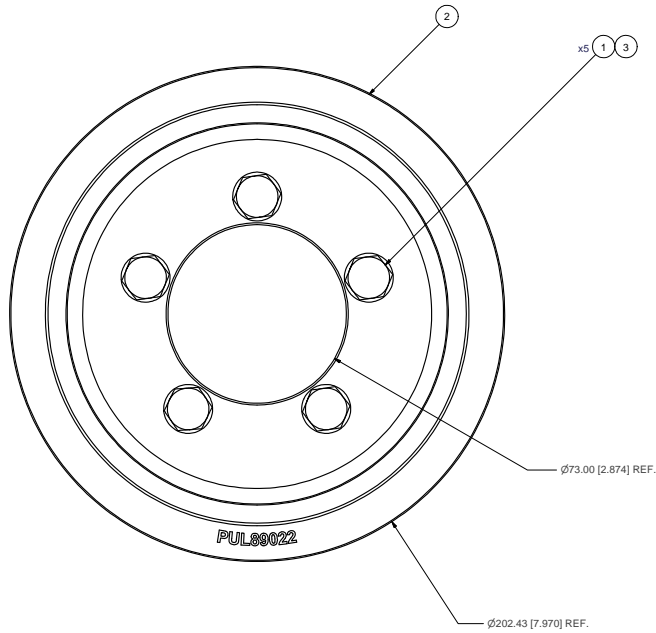
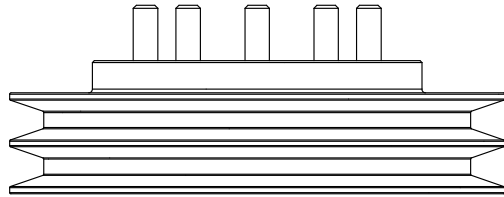

ISOMETRIC VIEW

- NOTES:**
- 1) USE SERVICABLE THREADLOCKER ON ALL FASTENERS TO ENGINE COMPONENTS AND TORQUE ALL BOLTS TO S.A.E. SPECIFICATIONS.
 - 2) SEE "TRANSARCTIC A/C COMPRESSOR MOUNT INSTALLATION DISCLAIMER".
 - 3) WT:≈ 11.56 LBS

ITEM	QTY	U/M	PART NUMBER	DESCRIPTION
3	5	EACH	WFA10000	WASHER, FLAT, 10mm, 8.8, PLT
2	1	EACH	PUL89022	PULLEY, CRANK, ISL, 8.9L, 2B/X, 8", '13
1	5	EACH	BTCT0050	BOLT, HEX, 10 x 1.5 x 50mm, 10.9, PLT

TRANSARCTIC INC.

UNSPECIFIED TOLERANCES:	MM (INCH)
ONE DECIMAL PLACE (X.0)	±0.10 (±0.004)
TWO DECIMAL PLACE (X.00)	±0.02 (±0.0008)
THREE DECIMAL PLACE (X.000)	±0.002 (±0.00008)
FRACTIONAL (1/16")	±0.005 (±0.0002)

DRAWN	DATE	TITLE
J Rodriguez	10/15/2013	
Checked		
val Jakowlew	10/15/2013	
GA		
James Stewart	10/15/2013	
MFG		
Ron Ingram	10/15/2013	
APPROVED		
Dale Mason	10/15/2013	

REV	DESCRIPTION	DATE	BY
0	RELEASED TO PRODUCTION	10/15/2013	JRB

THIS DRAWING CONTAINS PROPRIETARY CONFIDENTIAL INFORMATION OWNED BY TRANSARCTIC CANADA INC. THE DOCUMENT AND THE INFORMATION IN IT ARE NOT TO BE USED, DISCLOSED OR REPRODUCED WITHOUT EXPRESS WRITTEN PERMISSION OF THE COMPANY.

SIZE	DWG NO	REV
D	KPC89022	0

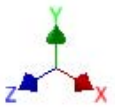
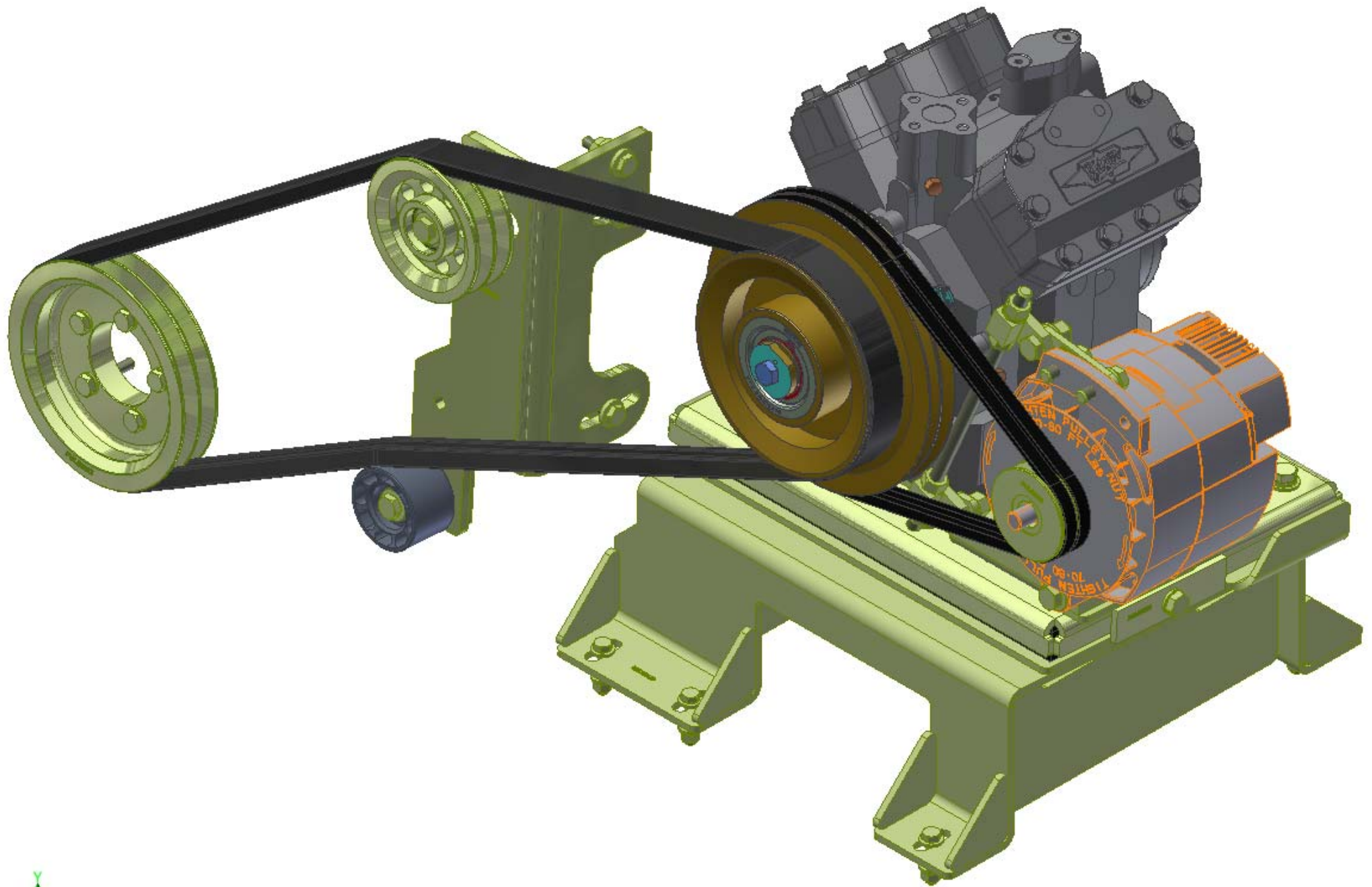

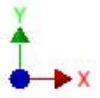
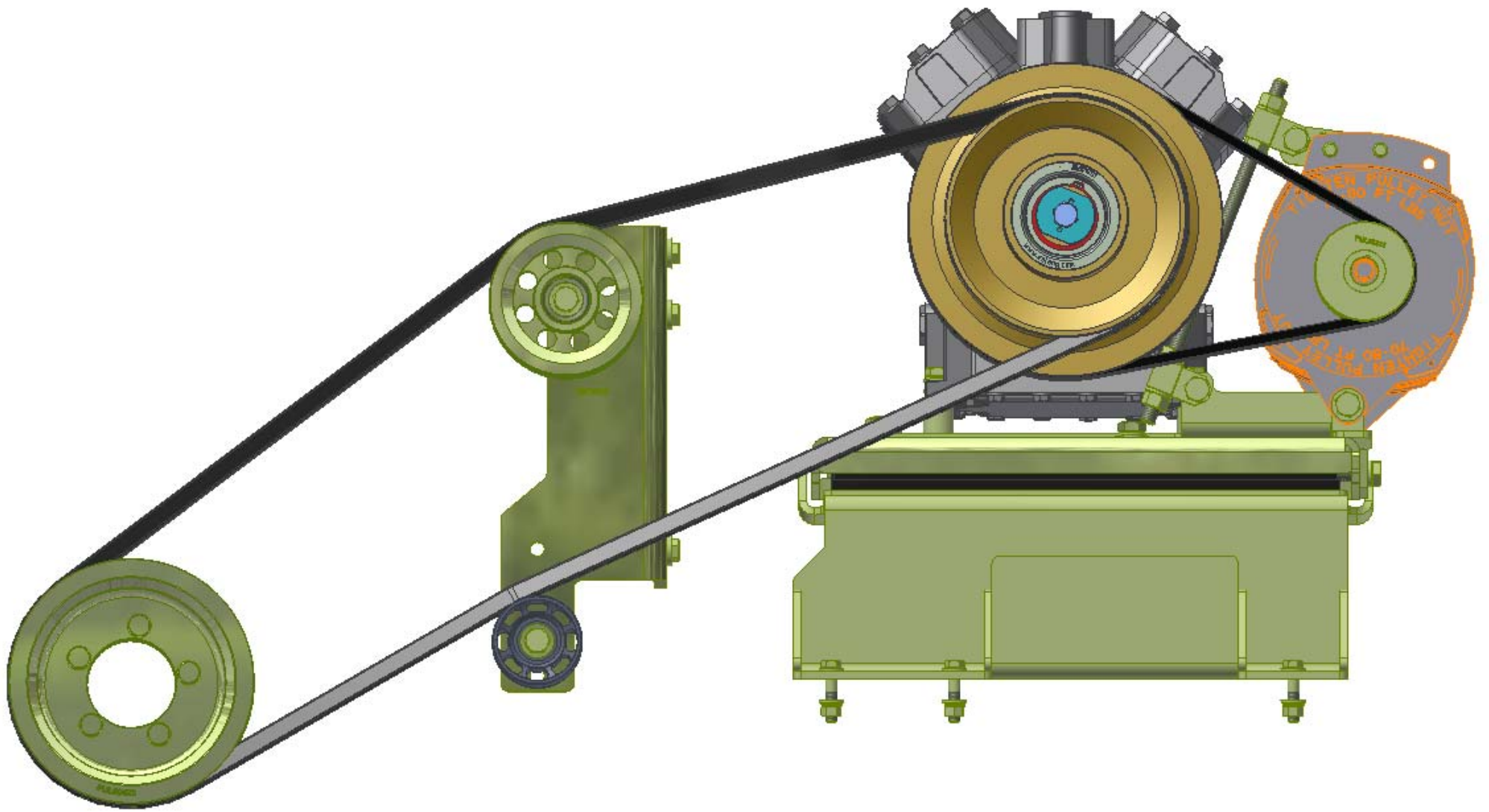

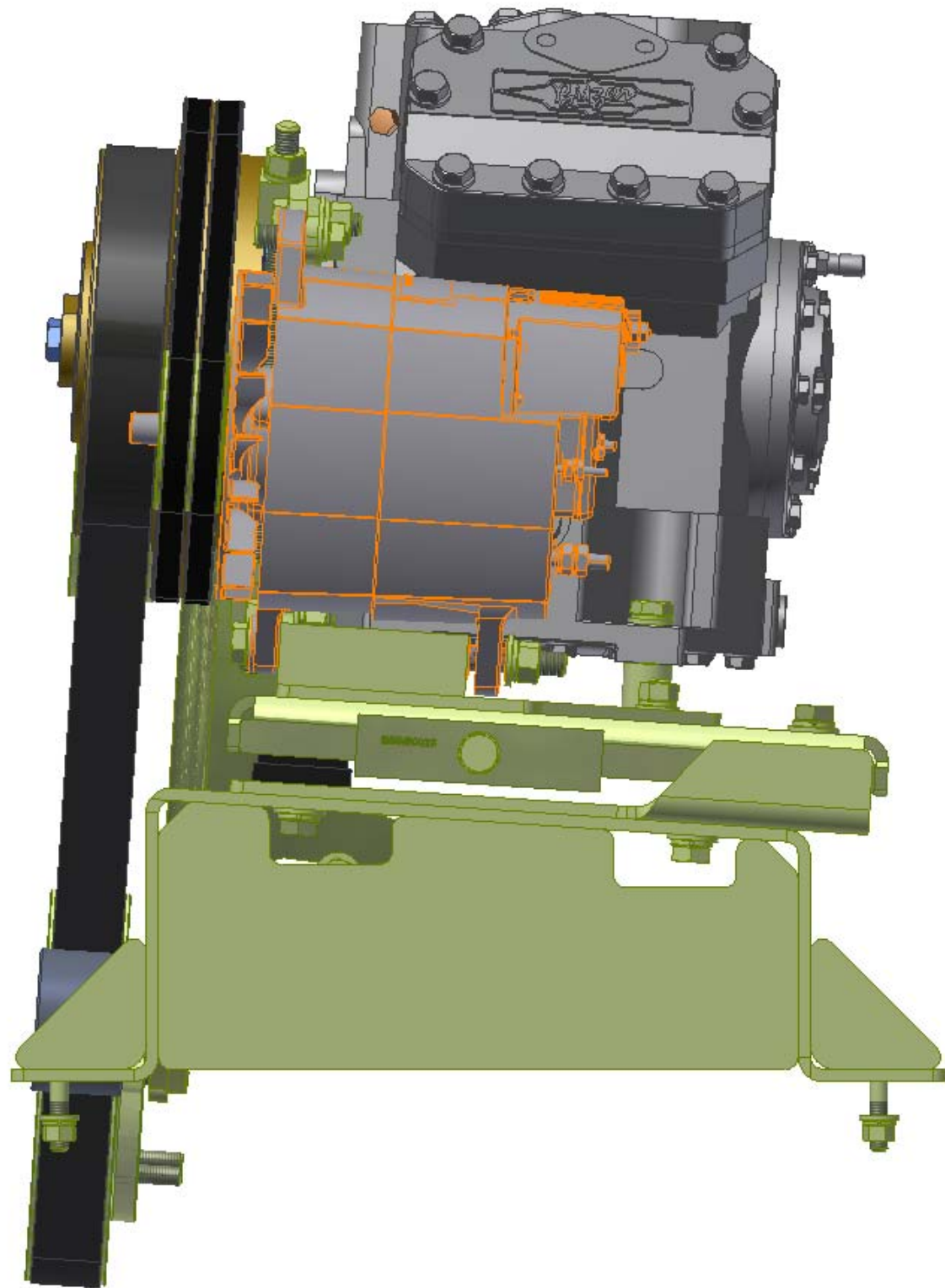

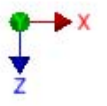
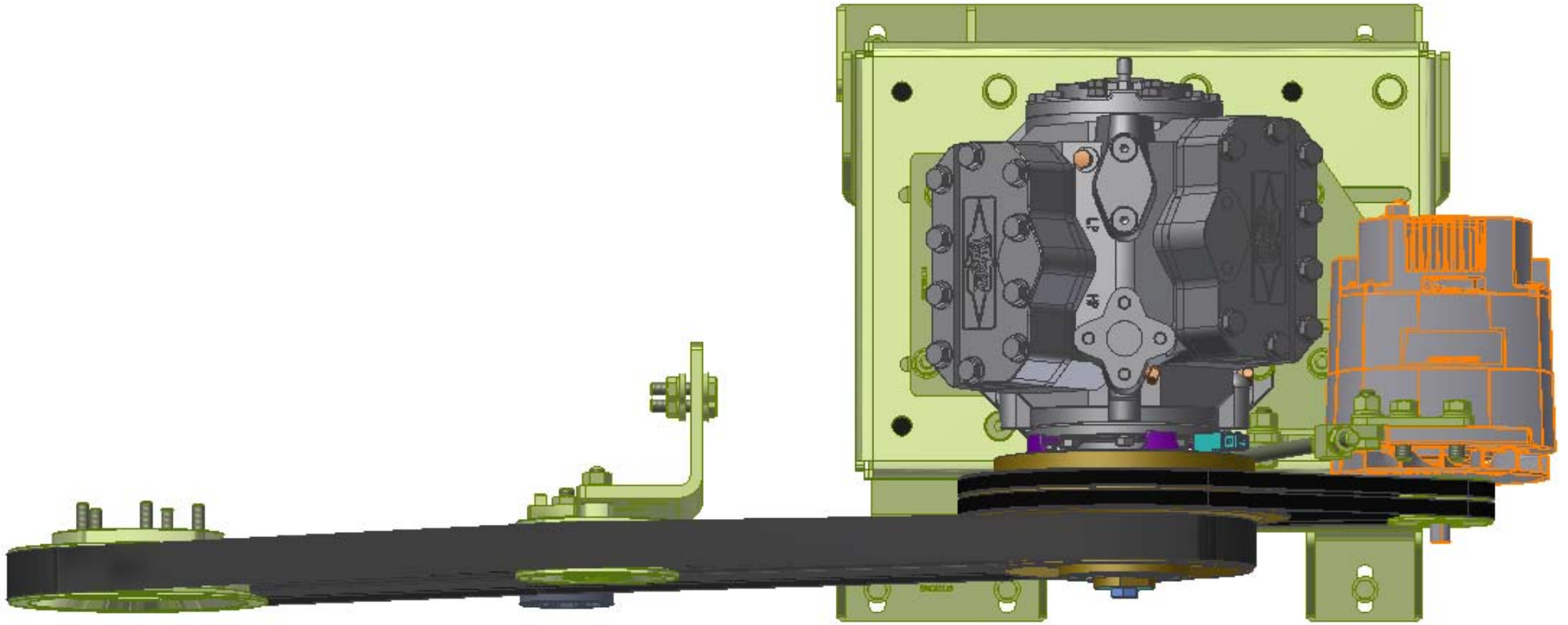

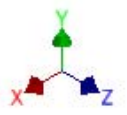
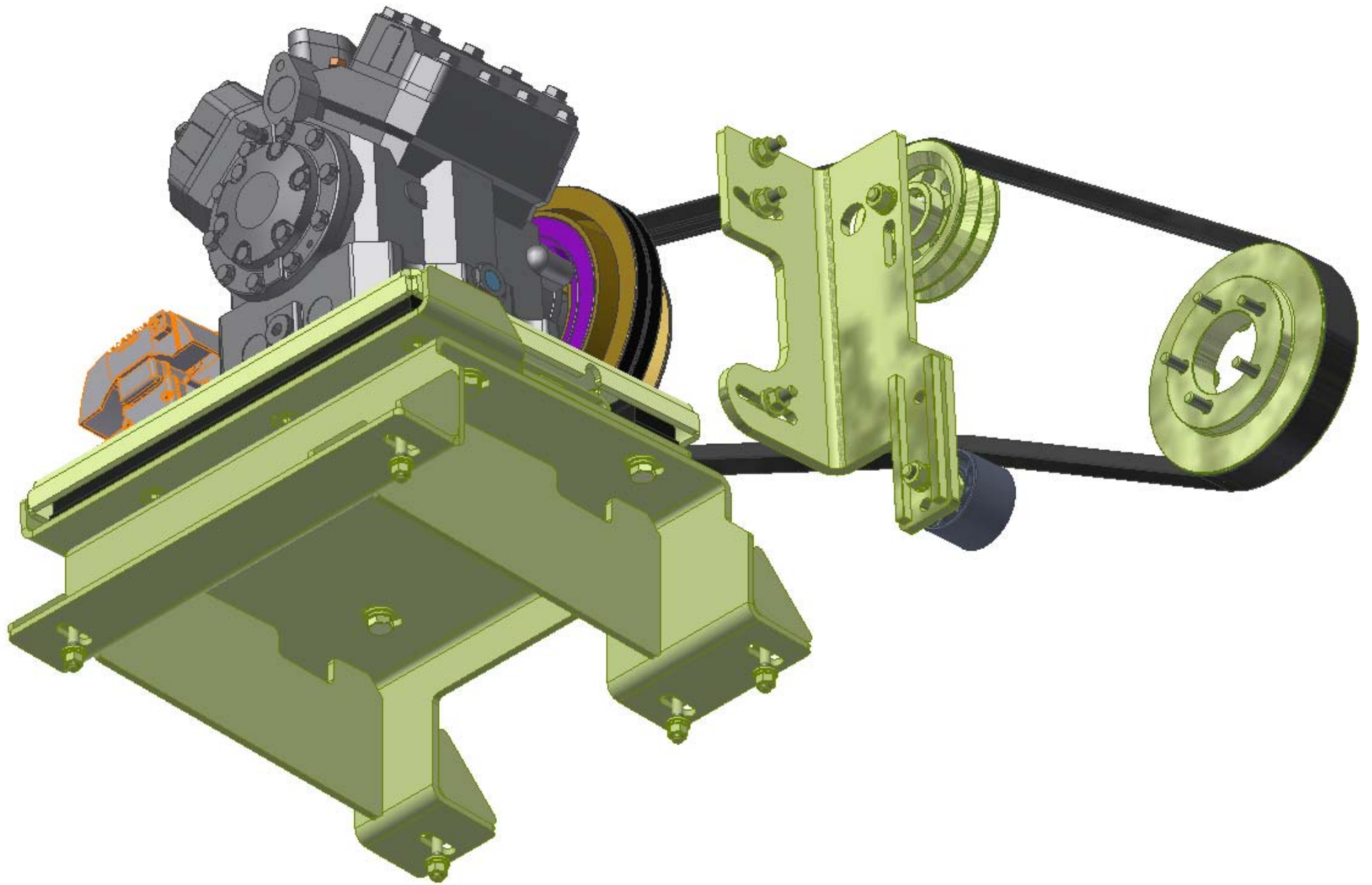

TransArctic A/C Compressor Mount Installation Disclaimer

All compressor mounts should be installed by qualified and trained personnel using proper tools and equipment in safe working conditions following industry standard guidelines for motor vehicle service and repair.

The installer of any compressor mount purchased from TransArctic must undertake all responsibility of issues arising from that compressor bracket being installed on any vehicle. As well as insure that a **proper and sufficient ground** is established between the compressors' clutches and the vehicle's engine. Mount functionality, operation and durability can all be compromised by an incompetent installation.

Due to the many different situations, parameters and application criteria, which are beyond the compressor mount manufacturer's control, TransArctic does not warrant design, durability, or operational functionality of any compressor mount improperly installed by another party.

With no implied guarantees it is the mount installer's strict responsibility to determine safety and functionality, of the compressor mount, at the time of installation.

Please contact TransArctic with any issue arising from installation so we may better improve the product. If you have any reservations about the compressor mount integrity contact TransArctic immediately at 1-877-COLD-AIR.

Mark OEM tensioner location

Install Kit

Check for Interferences

Check to ensure that the proper OEM tensioner orientation is maintained

Run engine with A/C system engaged for at least 10 minutes to run in belt

Check OEM tensioner orientation and adjust as required

Responsabilidad limitada de TransArctic en la instalación del soporte del compresor

Todos los soportes de los compresores deben ser instalados por personas calificadas y entrenadas, usando para ello los equipos y herramientas necesarios para esta labor en buenas condiciones y según las normas y guías para el servicio y/o reparación de motores de vehículos.

El instalador de los soportes comprados en TransArctic asume toda la responsabilidad de cualquier problema que surga en el soporte del compresor al vehículo; de igual manera es responsable que el cable a tierra sea conectado entre el embrague del compresor y el motor del vehículo.

Se advierte que el buen funcionamiento y la durabilidad del soporte pueden ser comprometidos por defectos en su instalación.

Debido a las diversas situaciones que se puedan presentar fuera del control del fabricante, TransArctic no garantiza el diseño, la durabilidad o el correcto funcionamiento de cualquier equipo inapropiadamente instalado por terceros.

Esta sobreentendido que el Instalador del montaje del compresor es estrictamente responsable de la seguridad y funcionamiento del equipo en el momento de la instalación.

Si tuviera algún problema o duda acerca de la instalación del soporte del compresor pongase en contacto inmediatamente con TransArctic al teléfono 1-877-COLD-AIR de modo que podamos mejorar nuestro producto.

Note la ubicación del medidor de tensión OEM

Instale el equipo

Controlar si hay interferencias.

Asegurese que el medidor de tensión mantenga la orientación justa.

Encienda el motor por lo menos 10 minutos con el sistema A/C enganchado para que la correa corra

Controle la orientación justa del medidor de tensión y ajuste a las condiciones requeridas del fabricante