

Bill of Materials Listing

TransArctic Canada Inc.

2/1/2017
Page 1 of 1

Product Number	Description	Date	Weight	Uof M	Yield
Line Component Prod#	Description	Bin Unit	Qty		
KMC81392	Mt Kit, ISL- D 2013, HDX , 1 QP-21, '14+	6/7/2013	2.73		0
10 BEL82134	Belt, 8gr, 2134mm (84") (5080840)	each	1		
20 BMC90007	Bkt, Cradle, ISL, R/H, TM-21,87mm,90/ccw	each	1		
30 BMC90008	Bkt, Cradle, ISL, L/H, TM-21,92mm,90/ccw	each	1		
40 KBC81392	Bag Kit, Fasteners, KMC81392/1092	each	1		

Bill of Materials Listing

TransArctic Canada Inc.

2/1/2017
Page 1 of 1

Product Number	Description		Date	Weight	Uof M	Yield
Line Component Prod#	Description	Bin	Unit	Qty		
KBC81392	Bag Kit, Fasteners, KMC81392/1092		10/22/2015	0.56		0
10	BTC08120		Bolt, Hex, 8 x 1.25 x 120mm, 10.9, Plt	each	2	
20	BTC08100		Bolt, Hex, 8 x 1.25 x 100mm, 10.9, Plt	each	2	
30	BTC08035		Bolt, Hex, 8 x 1.25 x 35mm, 10.9, Plt,FT	each	2	
40	WFA08000		Washer, Flat, 8mm, 8.8, Plt	each	6	
50	WLA08000		Washer, Lock, 8mm, 8.8, Plt	each	6	

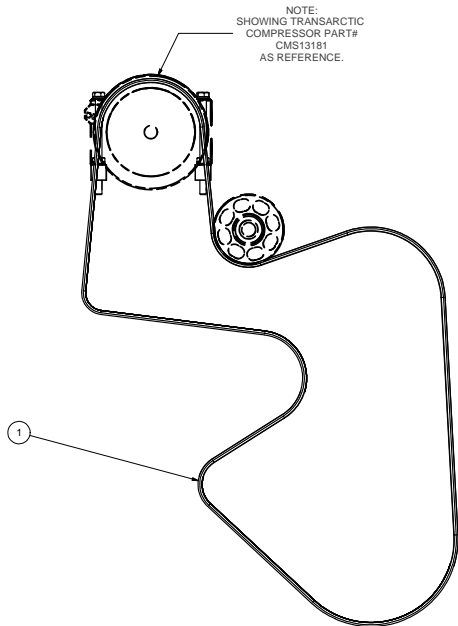
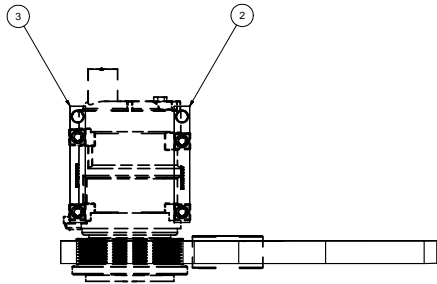

NOTE:
SHOWING TRANSARTIC
COMPRESSOR PART#
CMS13181
AS REFERENCE.

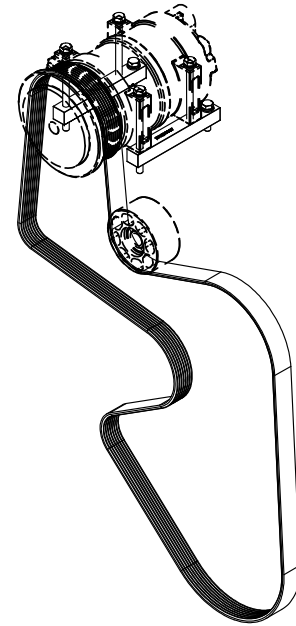
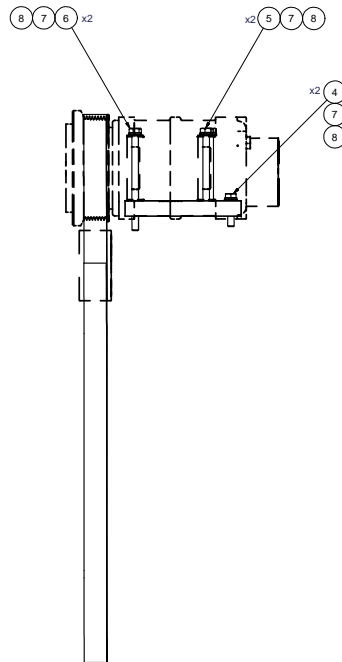

ISOMETRIC VIEW

NOTES:
1) USE SERVICABLE THREADLOCKER ON ALL FASTENERS TO ENGINE COMPONENTS AND TORQUE ALL BOLTS TO S.A.E. SPECIFICATIONS.
2) SEE 'TRANSARTIC A/C COMPRESSOR MOUNT INSTALLATION DISCLAIMER'.

ITEM	QTY	U/M	PART NUMBER	DESCRIPTION
8	6	EACH	WLA08000	WASHER, LOCK, 8mm, 8.8, PLT
7	6	EACH	WFA08000	WASHER, FLAT, 8mm, 8.8, PLT
6	2	EACH	BTC08120	BOLT, HEX, 8 x 1.25 x 120mm, 10.9, PLT
5	2	EACH	BTC08100	BOLT, HEX, 8 x 1.25 x 100mm, 10.9, PLT
4	2	EACH	BTC08035	BOLT, HEX, 8 x 1.25 x 35mm, 10.9, PLT
3	1	EACH	BMC90008	Bkt, Cradle, ISL, L/H, TM-21, 92mm, 90/ccw
2	1	EACH	BMC90007	Bkt, Cradle, ISL, R/H, TM-21, 87mm, 90/ccw
1	1	EACH	BEL2134	BELT, 6GR, 2134mm (84")

TRANSARTIC INC.

REVISION	DESCRIPTION	DATE	BY
0	RELEASED TO PRODUCTION	10/22/2015	JRS
1			

DRAWN	10/22/2015	TITLE
Jose Rodriguez		
CHECKED	10/22/2015	
Val Jakowlew		
APPROVED	10/22/2015	
James Stewart		
Dale Mason	10/22/2015	

THIS DRAWING CONTAINS PROPRIETARY CONFIDENTIAL INFORMATION OWNED BY TRANSARTIC CANADA INC. THE DOCUMENT AND THE INFORMATION IN IT ARE NOT TO BE USED, DISCLOSED OR REPRODUCED WITHOUT EXPRESS WRITTEN PERMISSION OF THE COMPANY.

UNSPECIFIED TOLERANCES:	ALL DIMS
ONE DECIMAL PLACE (X1)	0.1 (F0.1)
TWO DECIMAL PLACE (X2)	0.05 (F0.05)
THREE DECIMAL PLACE (X3)	0.025 (F0.025)
FRACTIONAL (X1/16)	1/16 (F0.0625)
ANGULAR	± 0.5°



DRAWING UNIT OF MEASURE	MM (INCH)
SCALE	1:3
DWG NO	KMC81392
REV	0



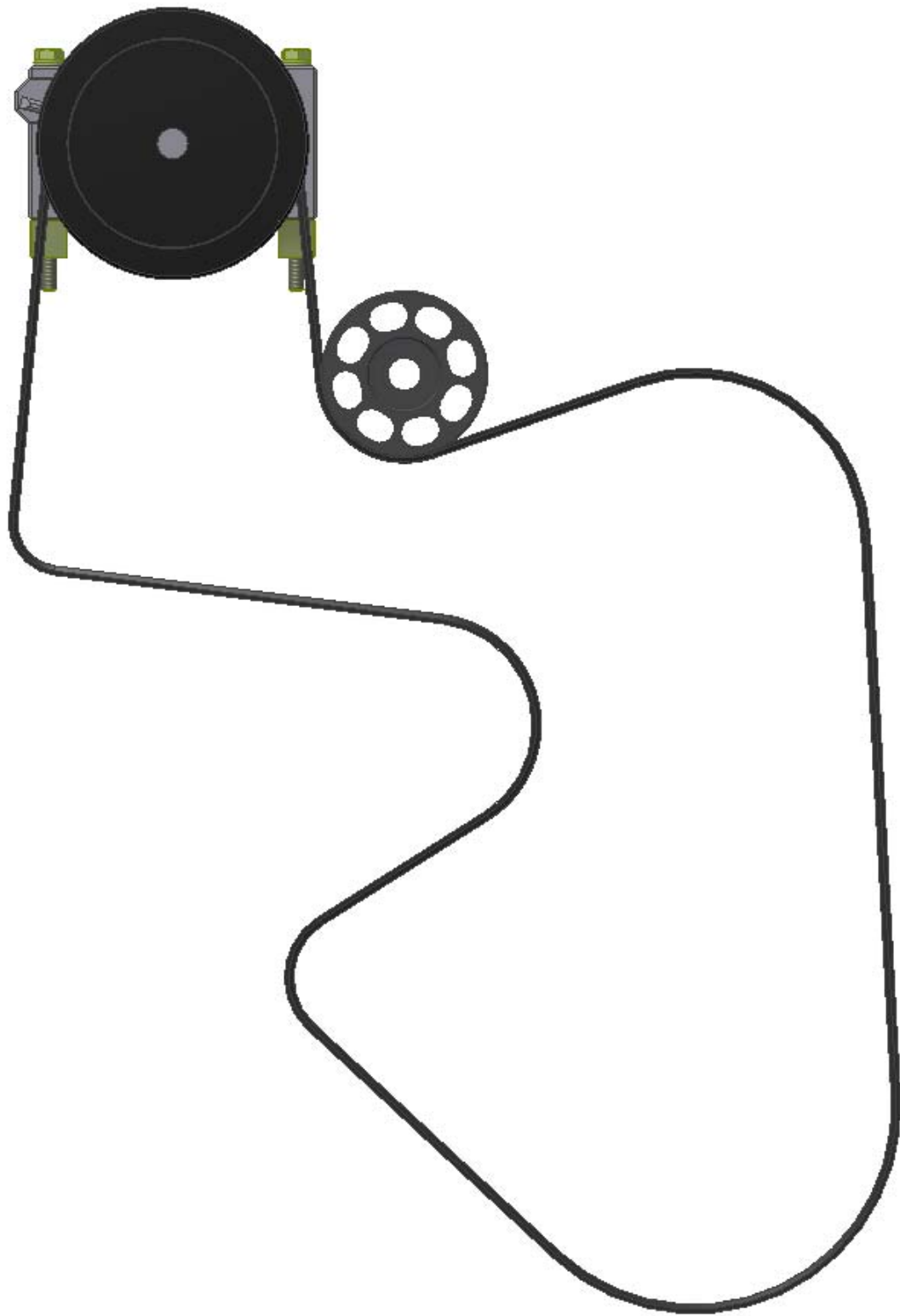

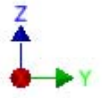



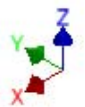

TransArctic A/C Compressor Mount Installation Disclaimer

All compressor mounts should be installed by qualified and trained personnel using proper tools and equipment in safe working conditions following industry standard guidelines for motor vehicle service and repair.

The installer of any compressor mount purchased from TransArctic must undertake all responsibility of issues arising from that compressor bracket being installed on any vehicle. As well as insure that a **proper and sufficient ground** is established between the compressors' clutches and the vehicle's engine. Mount functionality, operation and durability can all be compromised by an incompetent installation.

Due to the many different situations, parameters and application criteria, which are beyond the compressor mount manufacturer's control, TransArctic does not warrant design, durability, or operational functionality of any compressor mount improperly installed by another party.

With no implied guarantees it is the mount installer's strict responsibility to determine safety and functionality, of the compressor mount, at the time of installation.

Please contact TransArctic with any issue arising from installation so we may better improve the product. If you have any reservations about the compressor mount integrity contact TransArctic immediately at 1-877-COLD-AIR.

Mark OEM tensioner location

Install Kit

Check for Interferences

Check to ensure that the proper OEM tensioner orientation is maintained

Run engine with A/C system engaged for at least 10 minutes to run in belt

Check OEM tensioner orientation and adjust as required

Responsabilidad limitada de TransArctic en la instalación del soporte del compresor

Todos los soportes de los compresores deben ser instalados por personas calificadas y entrenadas, usando para ello los equipos y herramientas necesarios para esta labor en buenas condiciones y según las normas y guías para el servicio y/o reparación de motores de vehículos.

El instalador de los soportes comprados en TransArctic asume toda la responsabilidad de cualquier problema que surga en el soporte del compresor al vehículo; de igual manera es responsable que el cable a tierra sea conectado entre el embrague del compresor y el motor del vehículo.

Se advierte que el buen funcionamiento y la durabilidad del soporte pueden ser comprometidos por defectos en su instalación.

Debido a las diversas situaciones que se puedan presentar fuera del control del fabricante, TransArctic no garantiza el diseño, la durabilidad o el correcto funcionamiento de cualquier equipo inapropiadamente instalado por terceros.

Esta sobreentendido que el Instalador del montaje del compresor es estrictamente responsable de la seguridad y funcionamiento del equipo en el momento de la instalación.

Si tuviera algún problema o duda acerca de la instalación del soporte del compresor pongase en contacto inmediatamente con TransArctic al teléfono 1-877-COLD-AIR de modo que podamos mejorar nuestro producto.

Note la ubicación del medidor de tensión OEM

Instale el equipo

Controlar si hay interferencias.

Asegure que el medidor de tensión mantenga la orientación justa.

Encienda el motor por lo menos 10 minutos con el sistema A/C enganchado para que la correa corra

Controle la orientación justa del medidor de tensión y ajuste a las condiciones requeridas del fabricante