

# Bill of Materials Listing

TransArctic Canada Inc.

2/22/2008

Page 1 of 1

Product Number		Description	Bin	Date	Weight	Uof M	Yield
Line	Component Prod#	Description		Unit	Qty		
<b>KMN84571</b>		<b>Mt. Kit, MForce DT, CE300, 2 TM-21/16,07</b>		<b>02/22/08</b>	<b>14.98</b>		<b>0</b>
10	BMN80034	Bkt, Comp, Upper, CE200		each	1		
20	BMN80035	Bkt, Comp, Lower, CE300		each	1		
30	BMN80039	Bkt, Idler, Weldment, FE/CE300		each	1		
31	BMN80038	Bkt, Rad Hose, PMax DT, CE300		each	1		
50	PUL80074	Pulley, Idler, B/S, Wide, 76d (89102)		each	2		
52	BEL02615	Belt, 10gr, 2615mm (103")		each	1		
60	KBN84520	Bag Kit, Fasteners, KMN84520/71		each	1		
61	BMS16022	Bkt, TM-16 Spacer Plate		each	2		
62	SCD14010	Spacer, Col, Drl, 14mm x25.4o x10.32i		each	1		
72	CLP20040	Clamp, "P" type, #40, 1/2"w, 2 1/2", PC		each	1		
82	CLP36001	Clamp, Gear, #36, 1 13/16-2 3/4 (46/70mm)		each	2		

# Bill of Materials Listing

TransArctic Canada Inc.

2/22/2008

Page 1 of 1

Product Number		Description	Bin	Date	Weight	Uof M	Yield
Line	Component Prod#	Description		Unit	Qty		
<b>KBN84520</b>		<b>Bag Kit, Fasteners, KMN84520/71</b>		<b>02/22/08</b>	<b>1.52</b>		<b>0</b>
10	BTC08100	Bolt, Hex, 8 x 1.25 x 100mm, 10.9, Plt		each	4		
20	BTC08130	Bolt, Hex, 8 x 1.25 x 130mm, 10.9, Plt		each	4		
21	BTC08110	Bolt, Hex, 8 x 1.25 x 110mm, 10.9, Plt		each	4		
30	BTC10040	Bolt, Hex, 10 x 1.5 x 40mm, 10.9, Plt		each	1		
40	CSF10046	Capscrew, FH, 10 x 1.5 x 45mm, 10.9,Plt		each	1		
50	WFA08000	Washer, Flat, 8mm, 8.8, Plt		each	8		
60	WLA08000	Washer, Lock, 8mm, 8.8, Plt		each	9		
63	NTA08000	Nut, Hex, 8 x 1.25, 8.8, Plt		each	1		
70	WFA10000	Washer, Flat, 10mm, 8.8, Plt		each	1		
80	WLA10000	Washer, Lock, 10mm, 8.8, Plt		each	1		
90	BTS10001	Bolt, Shoulder, 10mm (89064)		each	2		
100	WDS17001	Washer, Dust Cover (89060)		each	2		
130	BTP04075	Bolt, Hex, 1/4-20unc, .75", 5, Plt		each	1		
140	NTP04000	Nut, Hex, 1/4-20unc, 5, Plt		each	1		
150	WFS04003	Washer, Flat, 1/4", 2, USS, Plt		each	1		

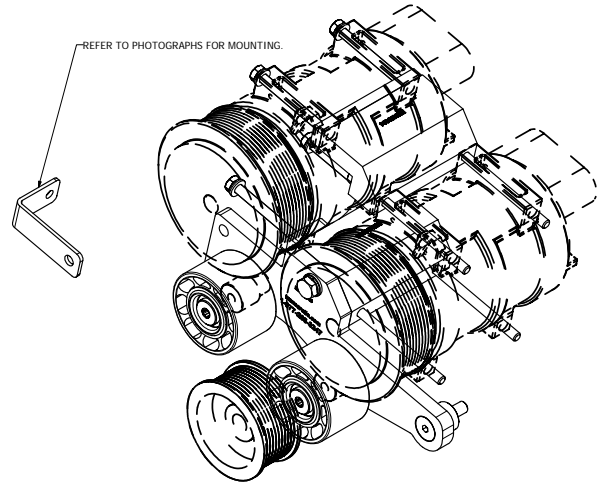
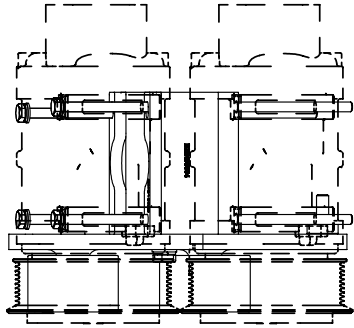

ISOMETRIC VIEW



USE 2 x BMS16022 SPACER PLATE AND 4 x BTC08110 BOLTS WHEN INSTALLING TM-16S. (6) (8)

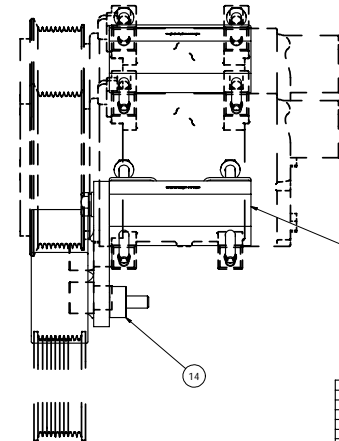
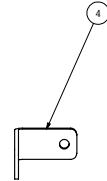
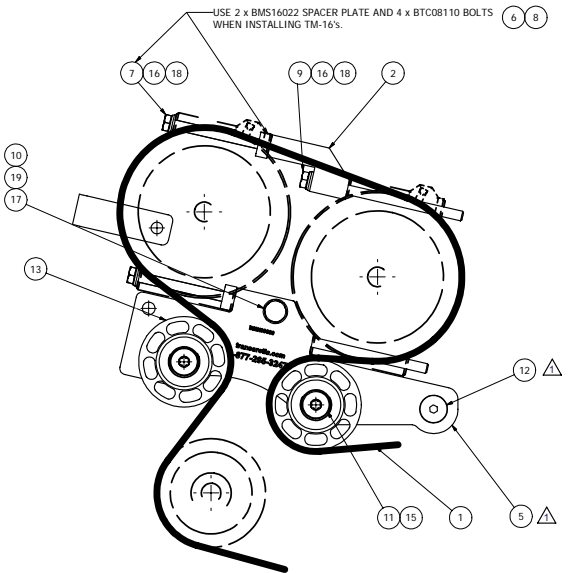

- NOTES:
- 1) USE SERVICABLE THREADLOCKER ON ALL FASTENERS TO ENGINE COMPONENTS AND TORQUE **ALL** BOLTS TO S.A.E. SPECIFICATIONS.
  - 2) SEE "TRANSARCTIC A/C COMPRESSOR MOUNT INSTALLATION DISCLAIMER".
  - 3) MODIFY EXISTING RADIATOR HOSE ON PASSENGER SIDE (TO CLEAR BELT), BY REMOVING HOSE AND FLIPPING END FOR END AND THEN RE-INSTALL ON THE ENGINE. (USING NEW BRKT SUPPLIED)

ITEM	QTY	U/M	PART NUMBER	DESCRIPTION
19	1	EACH	WLA10000	WASHER, LOCK, 10mm, 8.8, PLT
18	8	EACH	WLA08000	WASHER, LOCK, 8mm, 8.8, PLT
17	1	EACH	WFA10000	WASHER, FLAT, 10mm, 8.8, PLT
16	8	EACH	WFA08000	WASHER, FLAT, 8mm, 8.8, PLT
15	2	EACH	WDS17001	WASHER, DUST COVER (PULB0076)
14	1	EACH	SCD14010	SPACER, COL, DRL, 14mm x 25.4o x 10.32i
13	2	EACH	PUL80074	PULLEY, IDLER, BACKSIDE, P8, 74D, 46.27W
12	1	EACH	CSF10046	CAPSCREW, FH, 10 x 1.5 x 45mm, 10.9, PLT
11	2	EACH	BTS10001	BOLT, SHOULDER, 10mm (IDLER PULLEY)
10	1	EACH	BTC10040	BOLT, HEX, 10 x 1.5 x 40mm, 10.9, PLT
9	4	EACH	BTC08130	BOLT, HEX, 8 x 1.25 x 130mm, 10.9, PLT
8	4	EACH	BTC08110	BOLT, HEX, 8 x 1.25 x 110mm, 10.9, PLT
7	4	EACH	BTC08100	BOLT, HEX, 8 x 1.25 x 100mm, 10.9, PLT
6	2	EACH	BMS16022	BKT, TM-16, SPACER PLATE
5	1	EACH	BMN80039	BKT, IDLER, WELDMNT, FE/CE300
4	1	EACH	BMN80038	BKT, RAD HOSE, PMAAX DT, CE300
3	1	EACH	BMN80035	BKT, COMP, LOWER, CE300
2	1	EACH	BMN80034	BKT, COMP, UPPER, CE300
1	1	EACH	BEL02615	BELT, 10gr, 2615mm (103")

BILL OF MATERIALS			
3	DRAWN	05/03/07	
2	CHECKED	05/18/07	
1	BY	05/18/07	
0	RELEASED TO PRODUCTION	05/18/07	
REVISION	DESCRIPTION	DATE	BY
			James Stewart
			Ron Ingram
			Dale Mason
<small>THIS DRAWING CONTAINS PROPRIETARY CONFIDENTIAL INFORMATION OWNED BY TRANSARCTIC CANADA INC. THE DOCUMENT AND THE INFORMATION IT IS NOT TO BE USED, DISCLOSED OR REPRODUCED WITHOUT EXPRESS WRITTEN PERMISSION OF THE COMPANY.</small>			
<small>UNSPECIFIED TOLERANCES:</small> DIM DECIMAL PLACE (X) .00 (FRACTIONAL) 1/32 DIM DECIMAL PLACE (X) .00 (FRACTIONAL) 1/32 DIM DECIMAL PLACE (X) .00 (FRACTIONAL) 1/32 DIM DECIMAL PLACE (X) .00 (FRACTIONAL) 1/32			
DRAWING UNIT OF MEASURE		MM (INCH)	
SCALE		1:2	
DWG NO		KMN84571	
REV		3	
SHEET		1 OF 1	

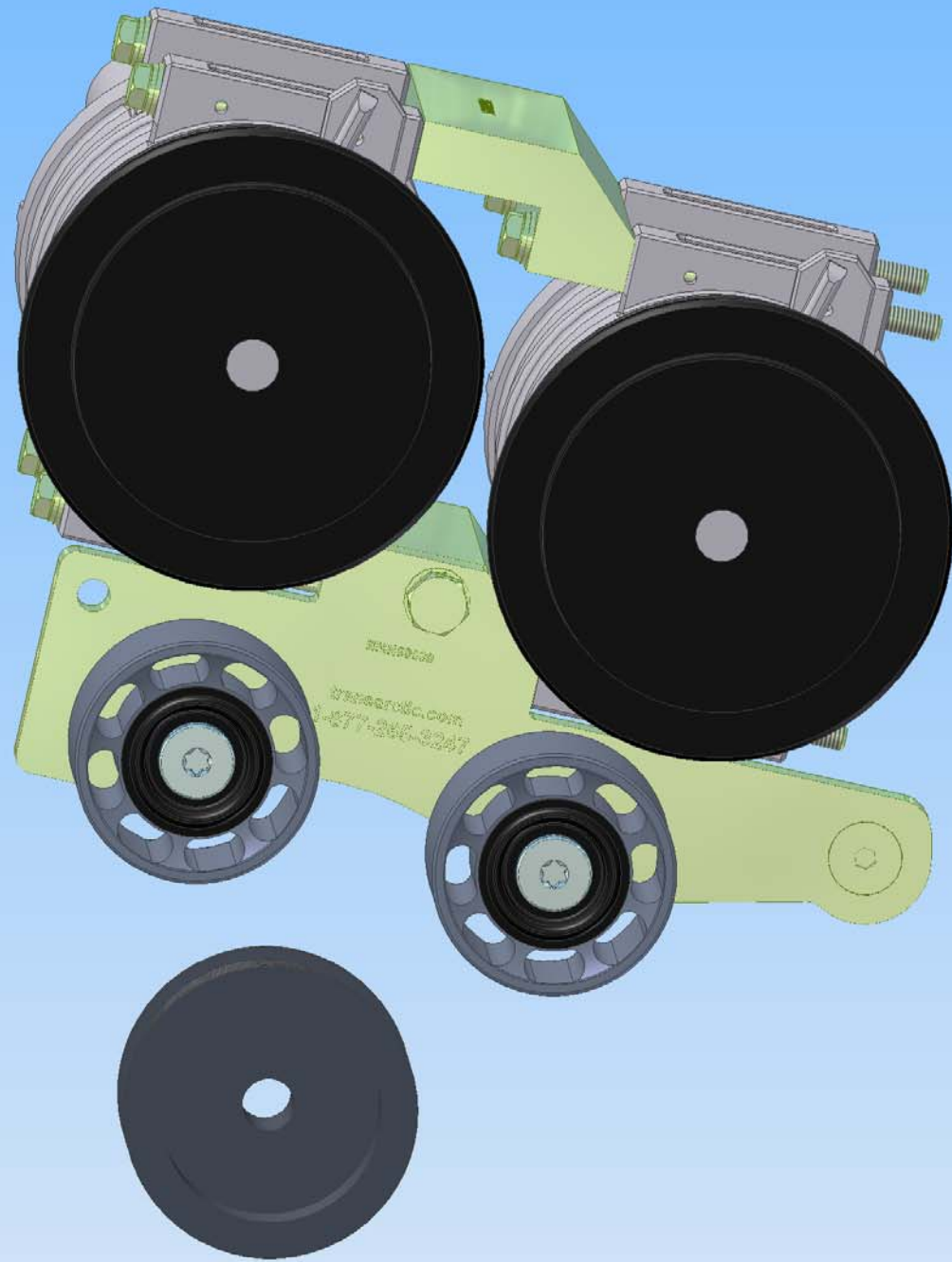

**KMN84571 - Mt. Kit, PMax DT, CE300, 2 TM-21/TM-16**

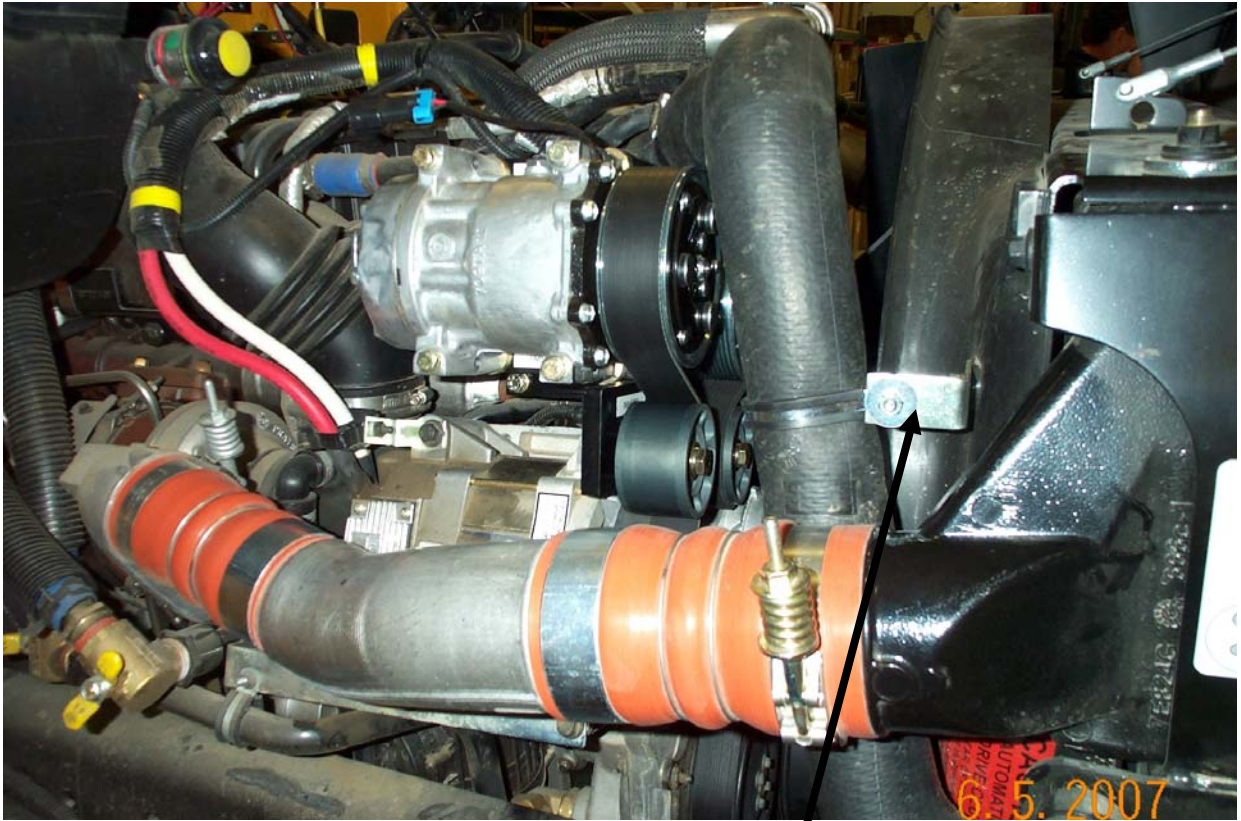

Rad hose is reversed and hose is supported from Rad shroud.

## **TransArctic A/C Compressor Mount Installation Disclaimer**

All compressor mounts should be installed by qualified and trained personnel using proper tools and equipment in safe working conditions following industry standard guidelines for motor vehicle service and repair.

The installer of any compressor mount purchased from TransArctic must undertake all responsibility of issues arising from that compressor bracket being installed on any vehicle. As well as insure that a **proper and sufficient ground** is established between the compressors' clutches and the vehicle's engine. Mount functionality, operation and durability can all be compromised by an incompetent installation.

Due to the many different situations, parameters and application criteria, which are beyond the compressor mount manufacturer's control, TransArctic does not warrant design, durability, or operational functionality of any compressor mount improperly installed by another party.

**With no implied guarantees it is the mount installer's strict responsibility to determine safety and functionality, of the compressor mount, at the time of installation.**

Please contact TransArctic with any issue arising from installation so we may better improve the product. If you have any reservations about the compressor mount integrity contact TransArctic immediately at 1-877-COLD-AIR.