

# Bill of Materials Listing

TransArctic Canada Inc.

6/8/2006  
Page 1 of 1

Product Number		Description	Bin	Date	Weight	Uof M	Yield
Line	Component Prod#	Description		Unit	Qty		
<b>KMC52671</b>		<b>Mt Kit, ISB, 5.9L, BBCV, 2 TM-21, '06</b>		<b>3/31/2006</b>	<b>38.91</b>		<b>0</b>
10	BEL61867	Belt, 6gr, 1867mm (73.5") (5060735)		each	1		
20	BMC59040	Bkt, Main, Weldmt, ISB, Conv		each	1		
30	BMC59038	Bkt, Main, Spacers, Block, ISB, Conv		each	1		
60	BMC59039	Bkt, Brace, Diag, D/S, Sup, ISB, Conv		each	1		
65	SCD22410	Spacer, Col, Drl, 122.38mm x25.4o x10.32i		each	1		
70	PUL80076	Pulley, Idler, Backside, P8, 76d (89062)		each	1		
80	TEN80002	Tenr, HD Spring, BackSide, CCW (89200A)		each	1		
90	KBC52671	Bag Kit, Fasteners, KMC52671/KMC52071		each	1		

# Bill of Materials Listing

TransArctic Canada Inc.

6/8/2006  
Page 1 of 1

Product Number		Description	Bin	Date	Weight	Uof M	Yield
Line	Component Prod#	Description		Unit	Qty		
<b>KBC52671</b>		<b>Bag Kit, Fasteners, KMC52671/KMC52071</b>		<b>3/31/2006</b>	<b>1.78</b>		<b>0</b>
10	BTS10001	Bolt, Shoulder, 10mm (89064)		each	1		
12	BTC10150	Bolt, Hex, 10 x 1.5 x 150mm, 10.9, Plt		each	1		
15	BTC10080	Bolt, Hex, 10 x 1.5 x 80mm, 10.9, Plt		each	1		
17	BTC10060	Bolt, Hex, 10 x 1.5 x 60mm, 10.9, Plt		each	2		
20	BTC10040	Bolt, Hex, 10 x 1.5 x 40mm, 10.9, Plt		each	1		
30	BTC10030	Bolt, Hex, 10 x 1.5 x 30mm, 10.9, Plt		each	5		
40	BTC08100	Bolt, Hex, 8 x 1.25 x 100mm, 10.9, Plt		each	8		
50	BTC08090	Bolt, Hex, 8 x 1.25 x 90mm, 10.9, Plt		each	2		
60	BTC08065	Bolt, Hex, 8 x 1.25 x 65mm, 10.9, Plt		each	1		
80	NTA10000	Nut, Hex, 10 x 1.5, 8.8, Plt		each	1		
90	WDS17001	Washer, Dust Cover (89060)		each	1		
100	WFA08000	Washer, Flat, 8mm, 8.8, Plt		each	8		
105	WFA10000	Washer, Flat, 10mm, 8.8, Plt		each	1		
110	WLA08000	Washer, Lock, 8mm, 8.8, Plt		each	11		
120	WLA10000	Washer, Lock, 10mm, 8.8, Plt		each	10		

8 7 6 5 4 3 2 1

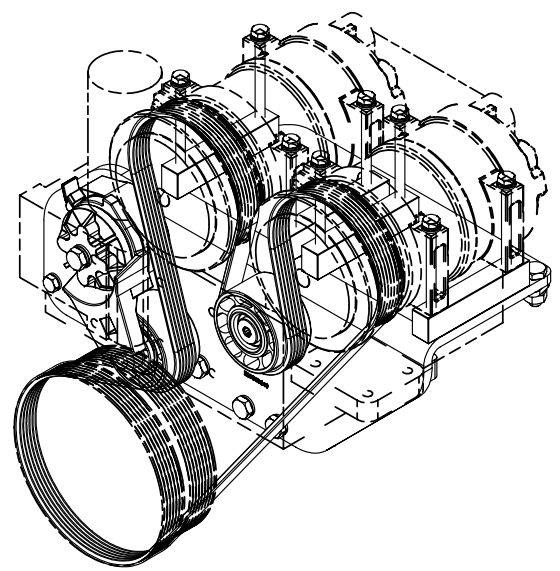
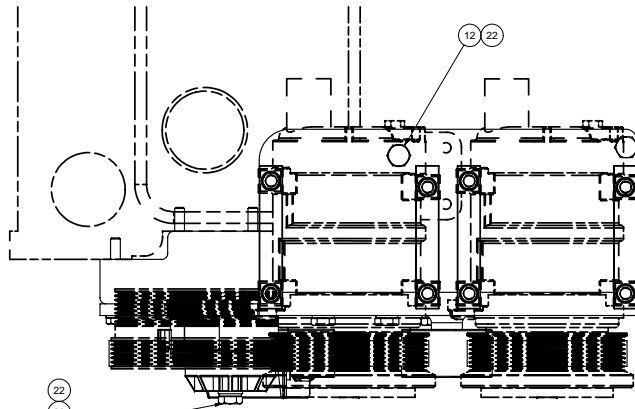

ISOMETRIC VIEW

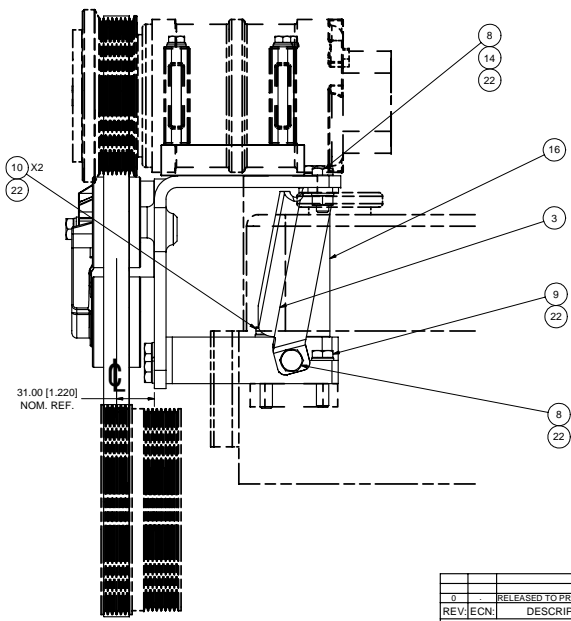
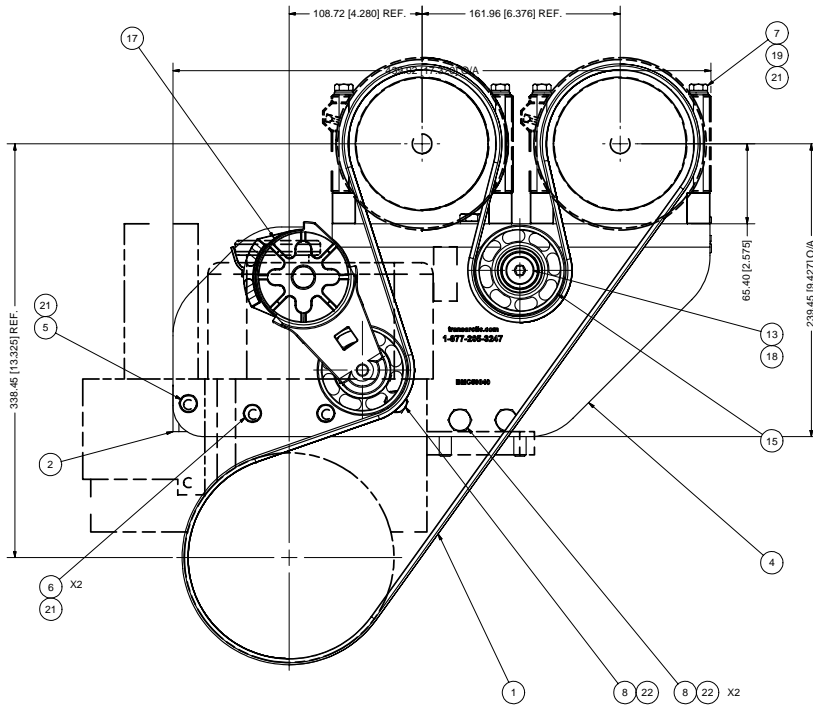

NOTES:  
 1) USE SERVICABLE THREADLOCKER ON ALL FASTENERS TO ENGINE COMPONENTS AND TORQUE ALL BOLTS TO S.A.E. SPECIFICATIONS.  
 2) SEE "TRANSARCTIC A/C COMPRESSOR MOUNT INSTALLATION DISCLAIMER".

ITEM	QTY	U/M	PART NUMBER	DESCRIPTION
22	10	EACH	WLA10000	WASHER, LOCK, 10mm, 8.8, PLT
21	11	EACH	WLA08000	WASHER, LOCK, 8mm, 8.8, PLT
20	1	EACH	WFA10000	WASHER, FLAT, 10mm, 8.8, PLT
19	8	EACH	WFA08000	WASHER, FLAT, 8mm, 8.8, PLT
18	1	EACH	WDS17001	WASHER, DUST COVER (PUL80076)
17	1	EACH	TENR0002	TENR, HD SPRING, BACKSIDE, CCW
16	1	EACH	SCD22410	SPACER, COL, DRL, 122.38mm x25.4o x10.32i
15	1	EACH	PUL80076	PULLEY, IDLER, BACKSIDE, P8, 76D, 39W
14	1	EACH	NTA10000	NUT, HEX, 10 x 1.5, 8.8, PLT
13	1	EACH	BTS10001	BOLT, SHOULDER, 10mm (IDLER PULLEY)
12	1	EACH	BTC10150	BOLT, HEX, 10 x 1.5 x 150mm, 10.9, PLT
11	1	EACH	BTC10080	BOLT, HEX, 10 x 1.5 x 80mm, 10.9, PLT
10	2	EACH	BTC10060	BOLT, HEX, 10 x 1.5 x 60mm, 10.9, PLT
9	1	EACH	BTC10040	BOLT, HEX, 10 x 1.5 x 40mm, 10.9, PLT
8	5	EACH	BTC10030	BOLT, HEX, 10 x 1.5 x 30mm, 10.9, PLT
7	8	EACH	BTC08100	BOLT, HEX, 8 x 1.25 x 100mm, 10.9, PLT
6	2	EACH	BTC08090	BOLT, HEX, 8 x 1.25 x 90mm, 10.9, PLT
5	1	EACH	BTC08065	BOLT, HEX, 8 x 1.25 x 65mm, 10.9, PLT
4	1	EACH	BMC59040	BKT, MAIN, WELDMT, ISB, CONV
3	1	EACH	BMC59039	BKT, BRACE, DIAG, D/S, SUP, ISB, CONV
2	1	EACH	BMC59038	BKT, MAIN, SPACER, BLOCK, ISB, CONV
1	1	EACH	BEL61867	BELT, 6sr, 1867mm (73.5")

TRANSARCTIC INC.

REV	DESCRIPTION	DATE	BY	VAL
0	RELEASED TO PRODUCTION	5/1/2006	GA	
1			James Stewart	4/22/2006
2			Val Jakovlew	4/22/2006
3			Dale Mason	4/22/2006

DRWN	vjakovlew	4/22/2006	
CHKD	Ron Ingram	4/22/2006	
REV	GA	4/22/2006	
APPROVED	Val Jakovlew	4/22/2006	
DATE	Dale Mason	4/22/2006	
BILL OF MATERIALS			
<b>TRANSARCTIC INC.</b>			
		TITLE	
		MT KIT, ISB, 5.9L, BBCV, 2 TM-21, '06	
SIZE	DWG NO	REV	
D	KMC52671	0	
SCALE	1:2	SHEET	1 OF 1

UNSPECIFIED TOLERANCES:  
 DIM DECIMAL PLACE (X) .00  
 DIM FRACTIONAL PLACE (X) .00  
 DIM ANGULAR (X) .01

THIRD ANGLE PROJECTION

8 7 6 5 4 3 2 1

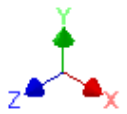
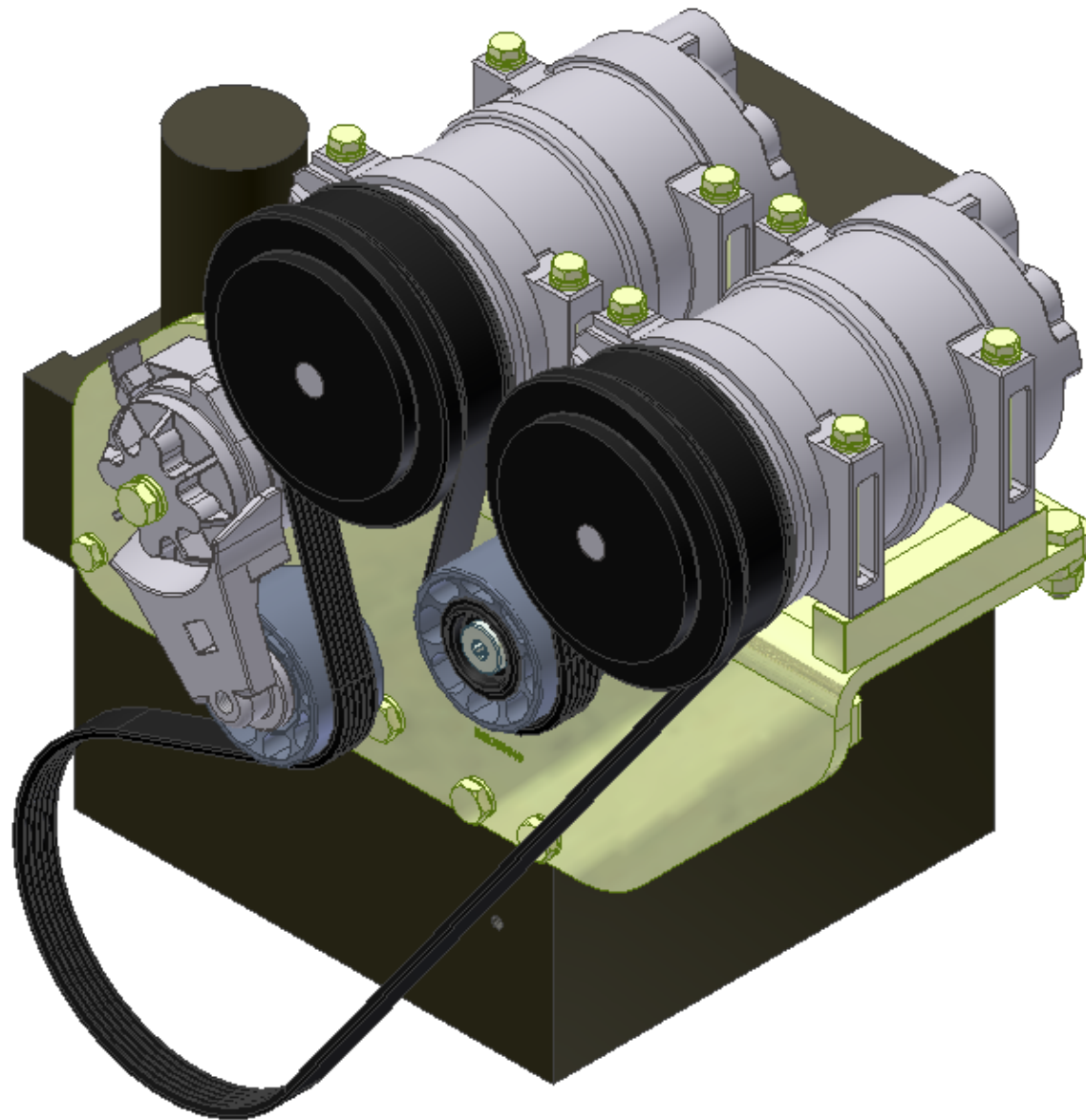

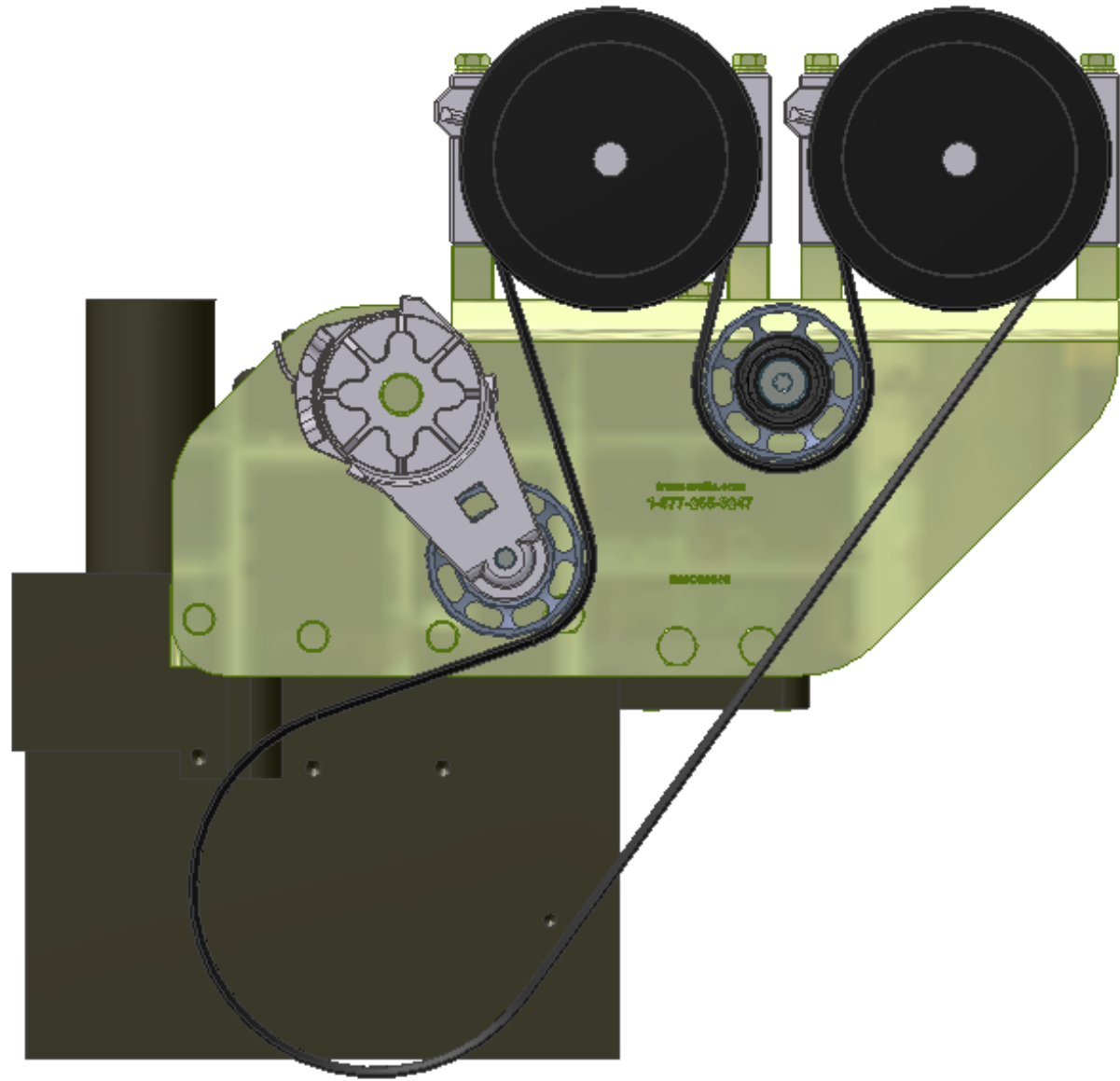

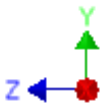
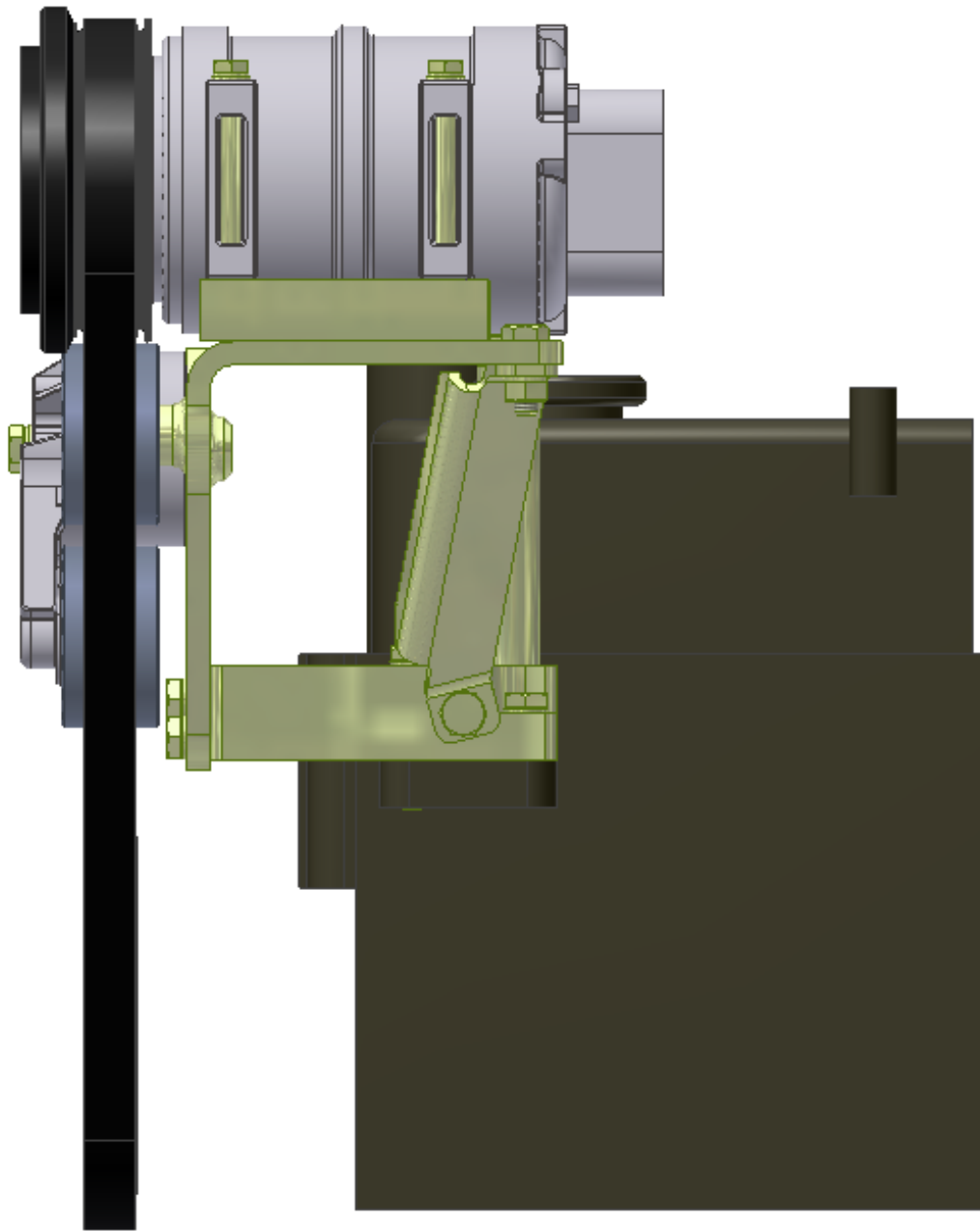

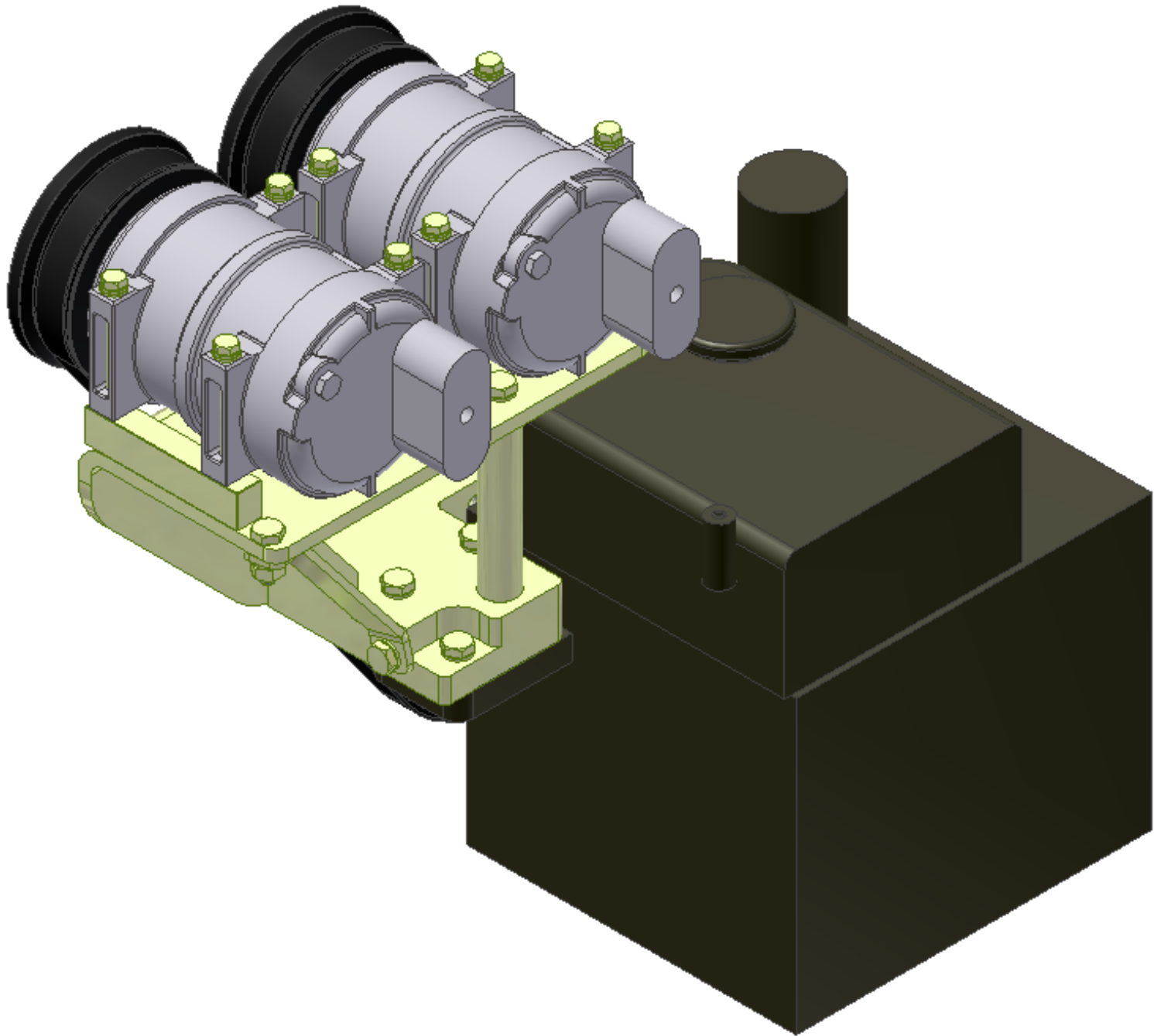



Install bolts finger tight to hold in place then put on Main Bracket BMC59040

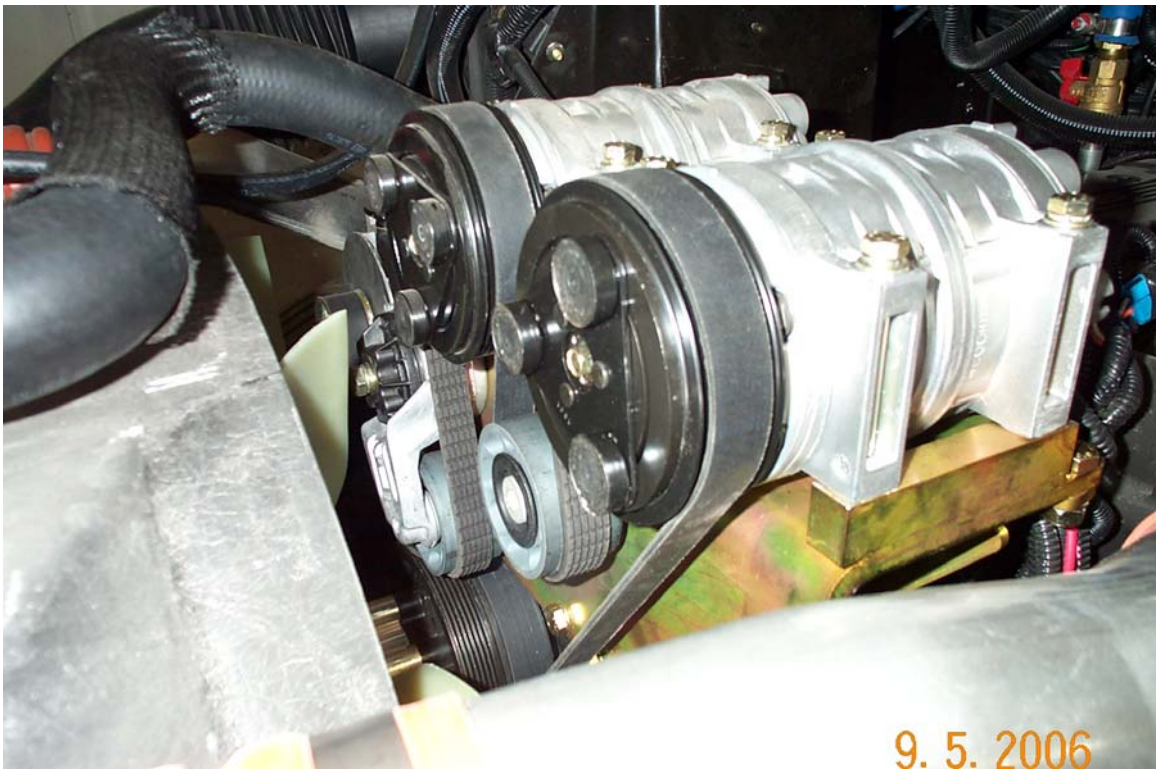



## **TransArctic A/C Compressor Mount Installation Disclaimer**

All compressor mounts should be installed by qualified and trained personnel using proper tools and equipment in safe working conditions following industry standard guidelines for motor vehicle service and repair.

The installer of any compressor mount purchased from TransArctic must undertake all responsibility of issues arising from that compressor bracket being installed on any vehicle. Mount functionality, operation and durability can all be compromised by an incompetent installation.

Due to the many different situations, parameters and application criteria, which are beyond the compressor mount manufacturer's control, TransArctic does not warrant design, durability, or operational functionality of any compressor mount improperly installed by another party.

**With no implied guarantees it is the mount installer's strict responsibility to determine safety and functionality, of the compressor mount, at the time of installation.**

Please contact TransArctic with any issue arising from installation so we may better improve the product. If you have any reservations about the compressor mount integrity contact TransArctic immediately at 1-877-COLD-AIR.