

CL1	CL2	QTY	NUMBER	CHANGE	DD. MM. YY	DRAW	CHECK

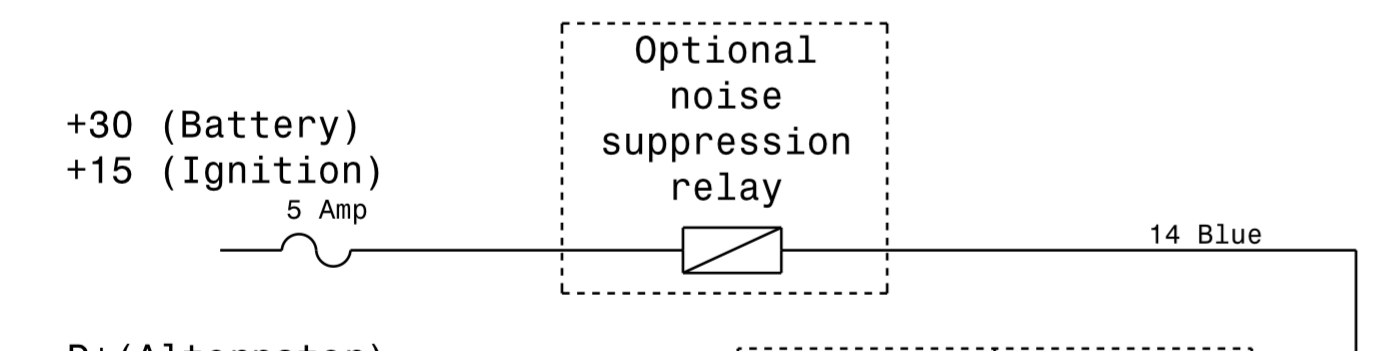

REF./POS. DIM	INFORMATION DIM	NOT SCALED DIM
PERMISSIBLE DEVIATION FOR DIM WITHOUT TOLERANCES	VOLTAGE	WEIGHT
ANSI	12	CAD SYSTEM
MATERIAL		CATIA V5R19
SURFACE PROTECTION		

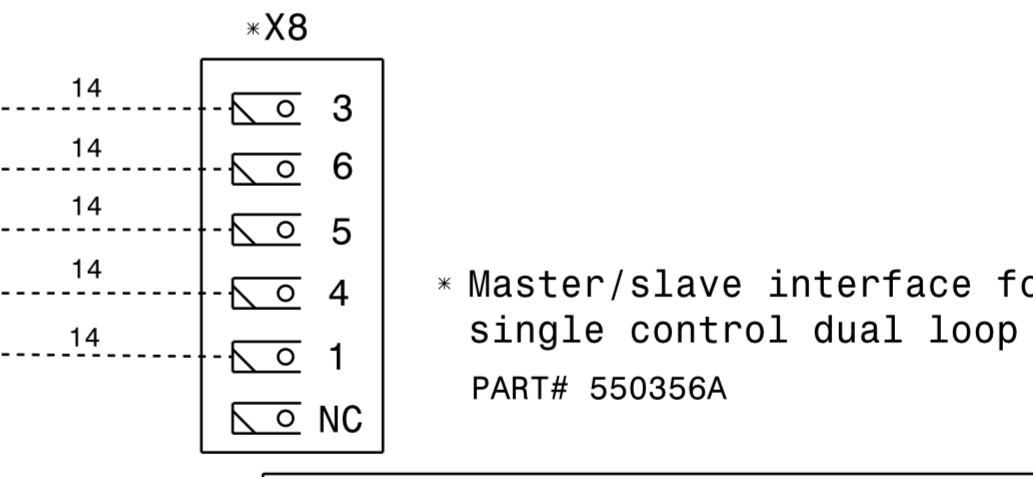
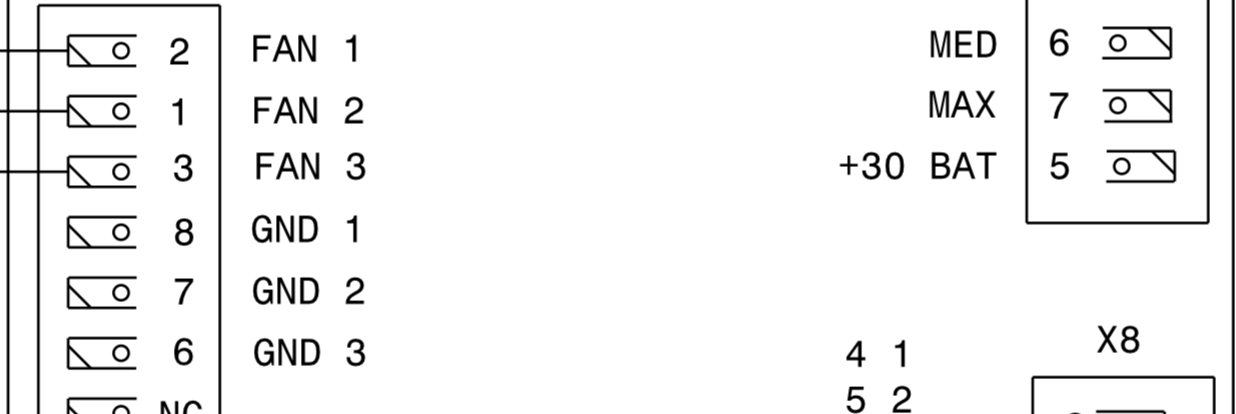
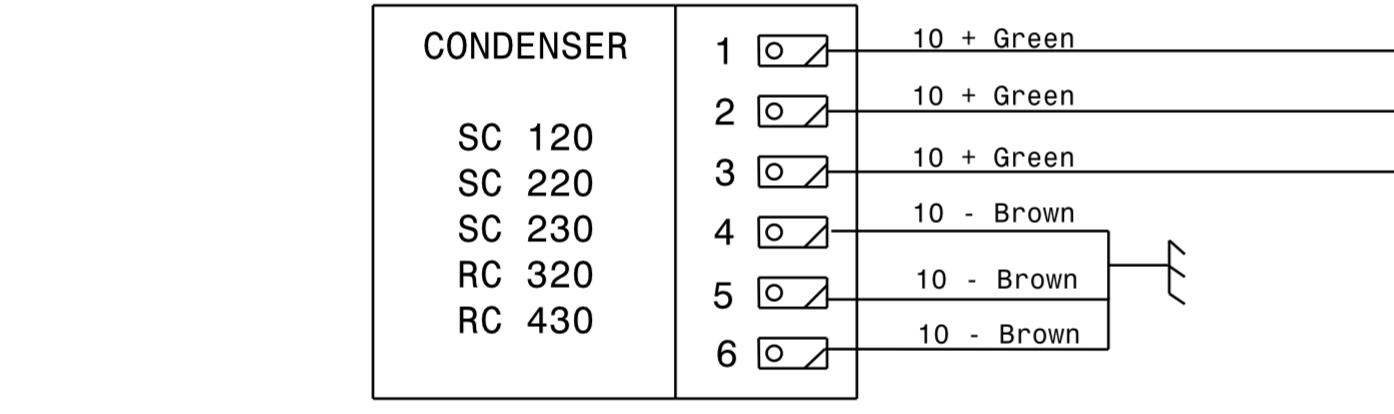
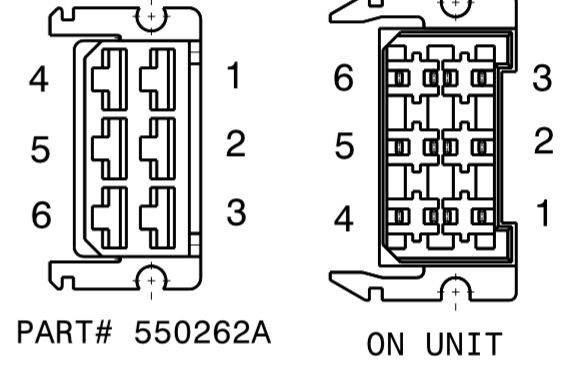
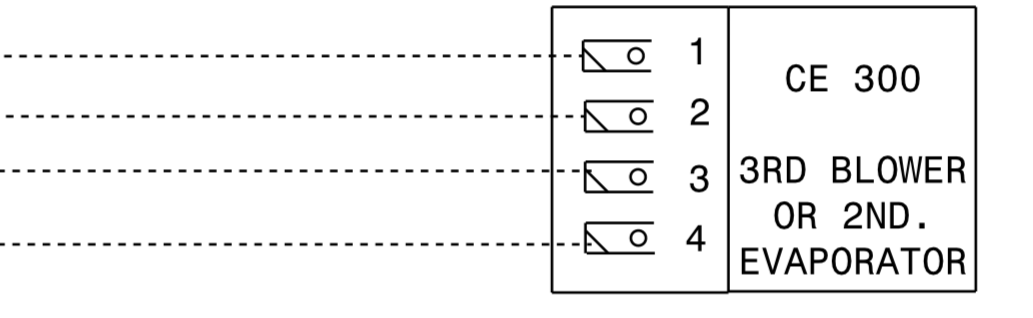
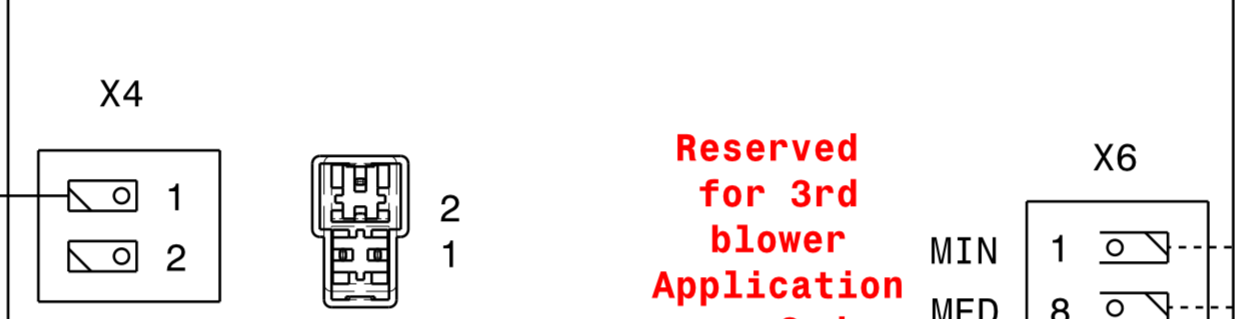
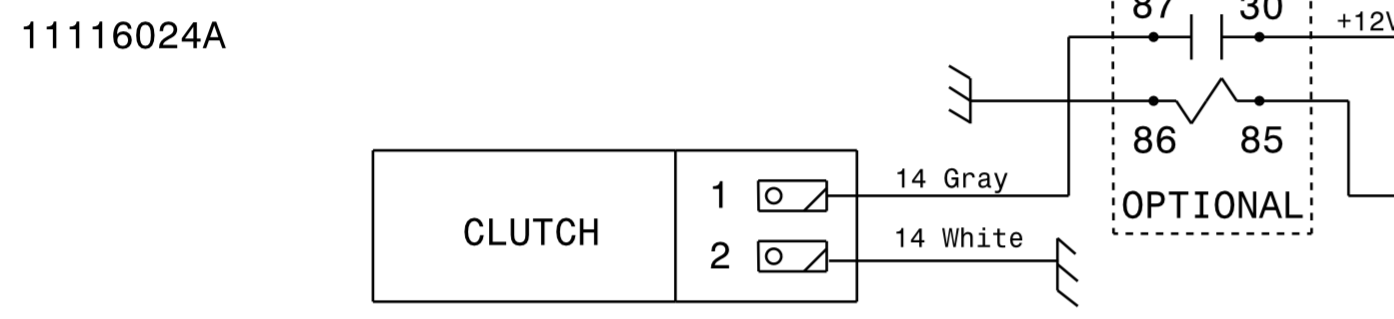
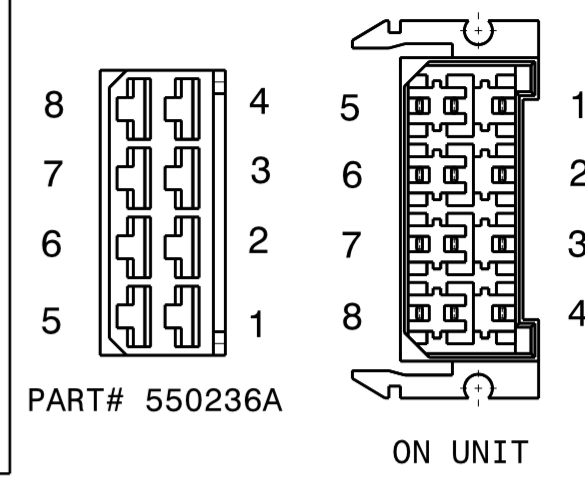
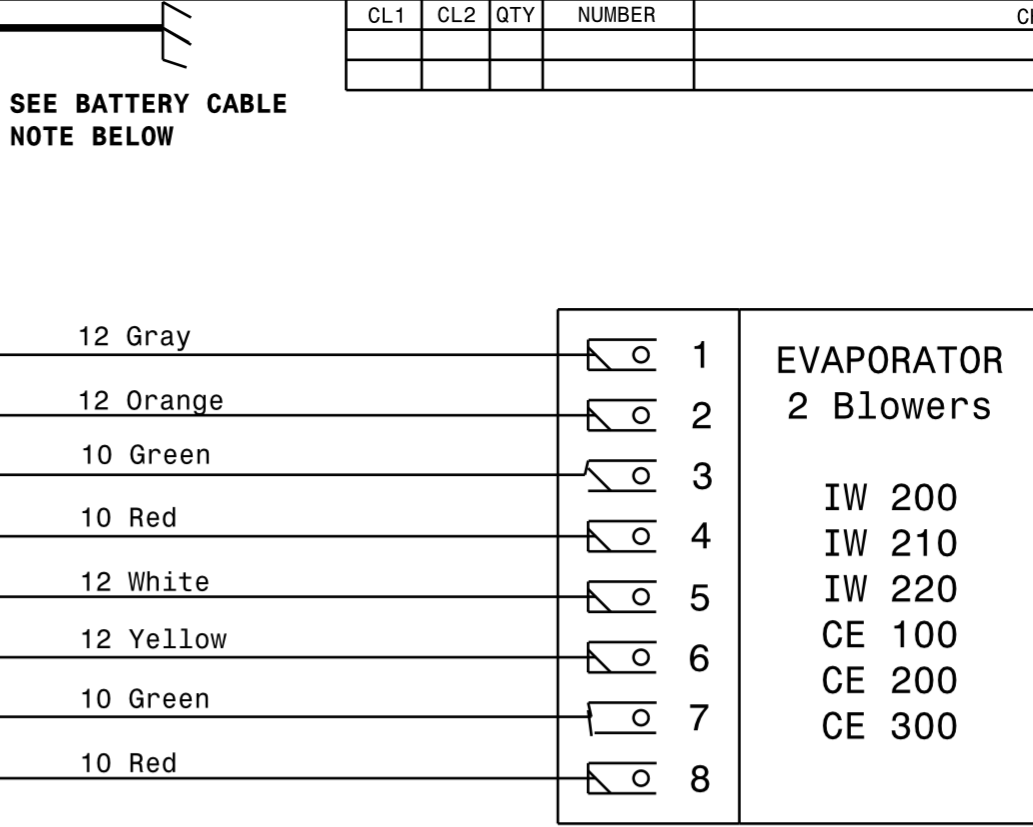
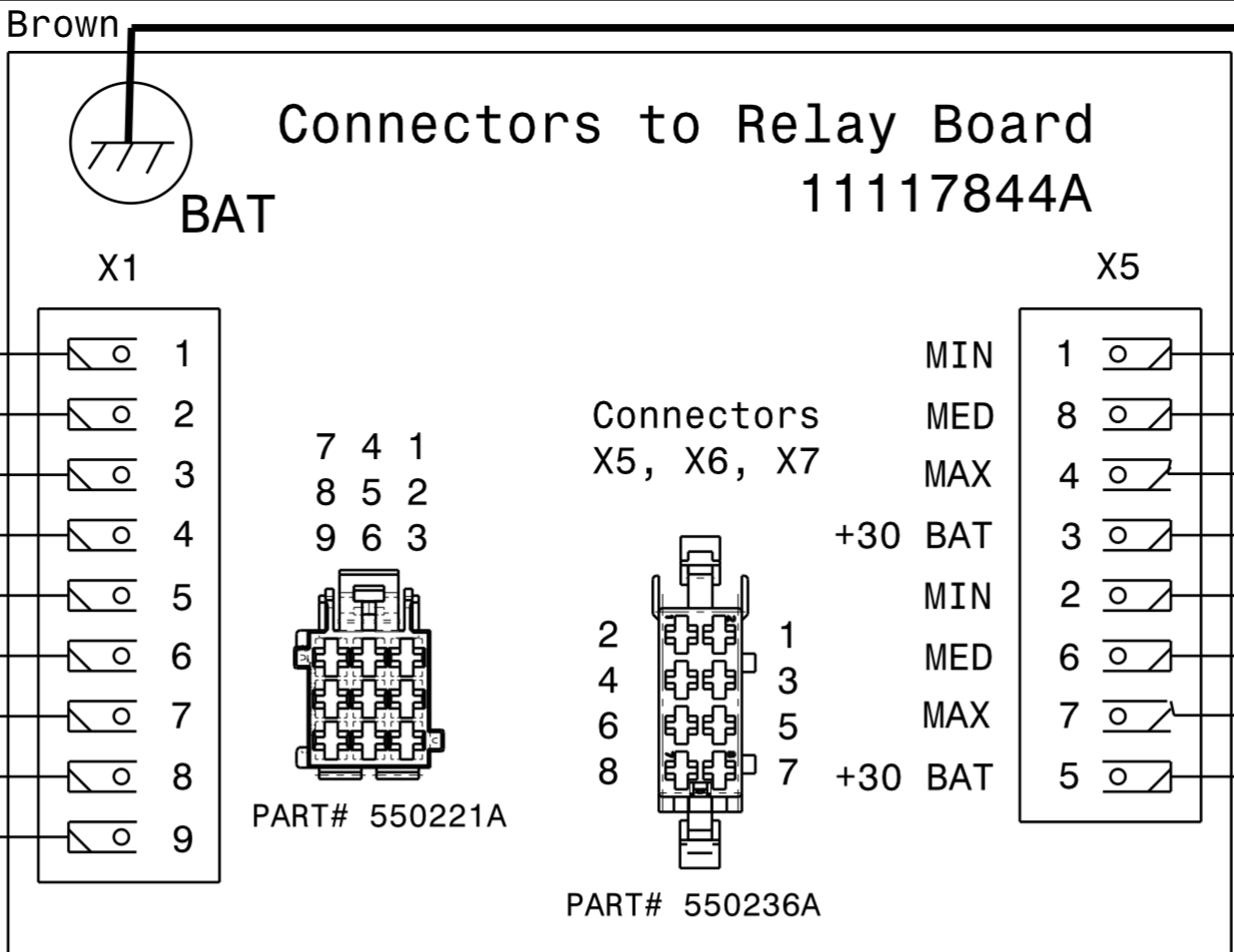
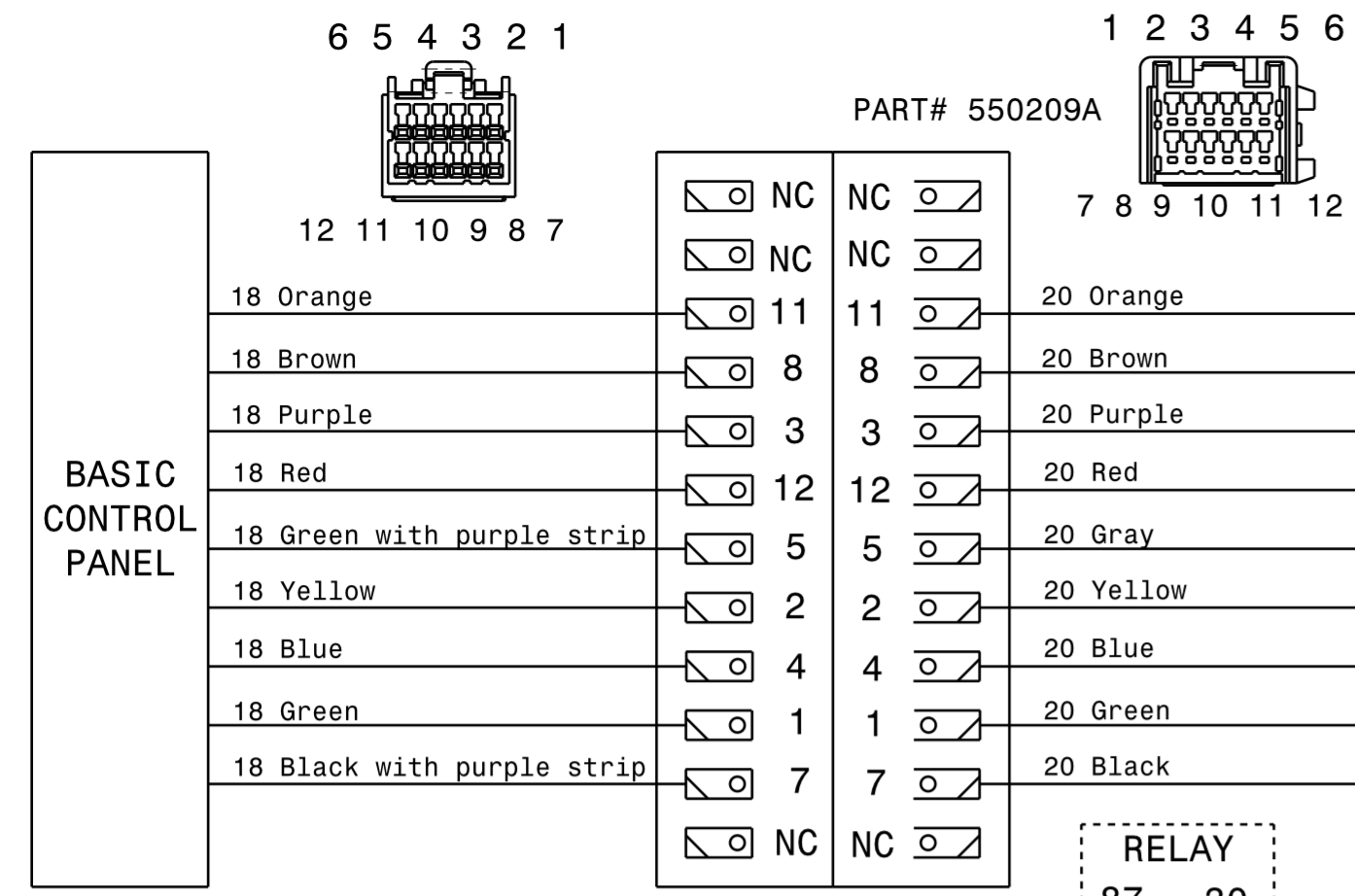
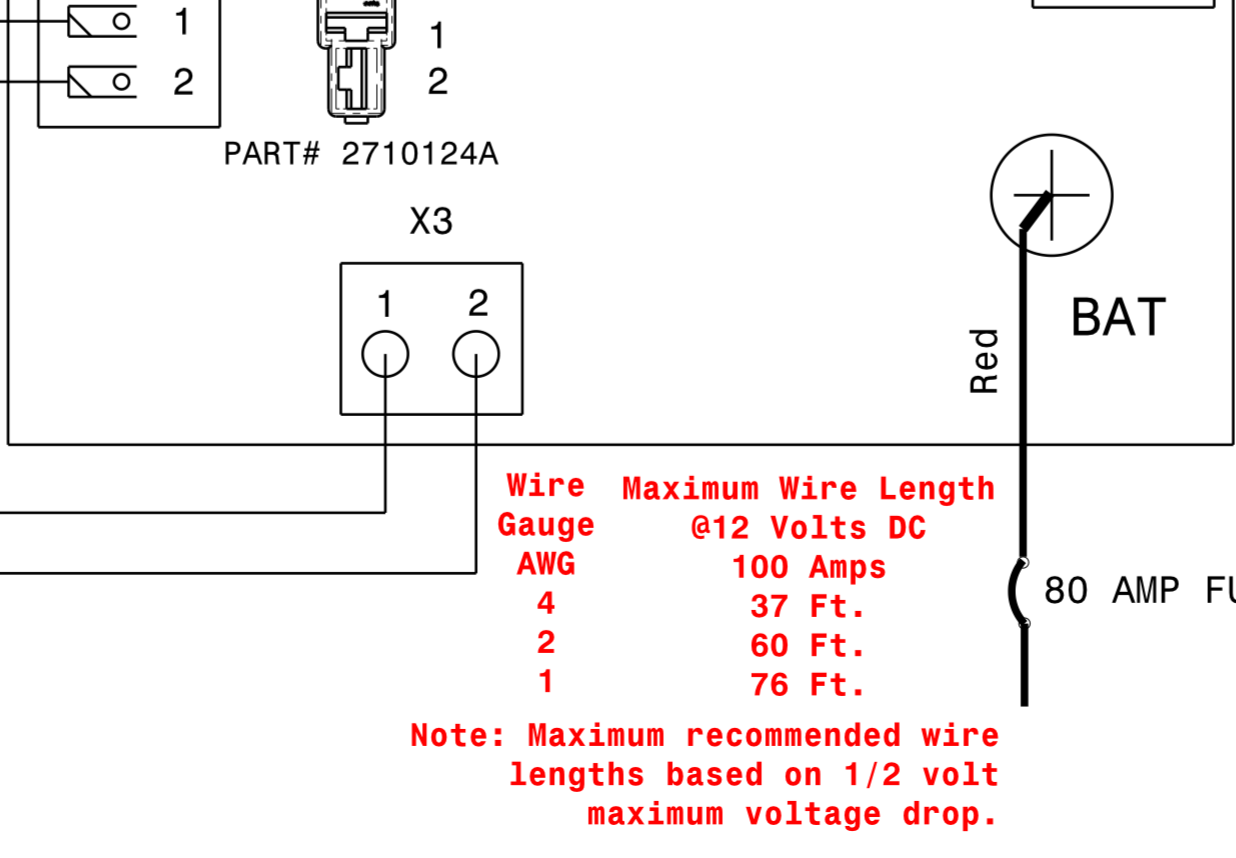
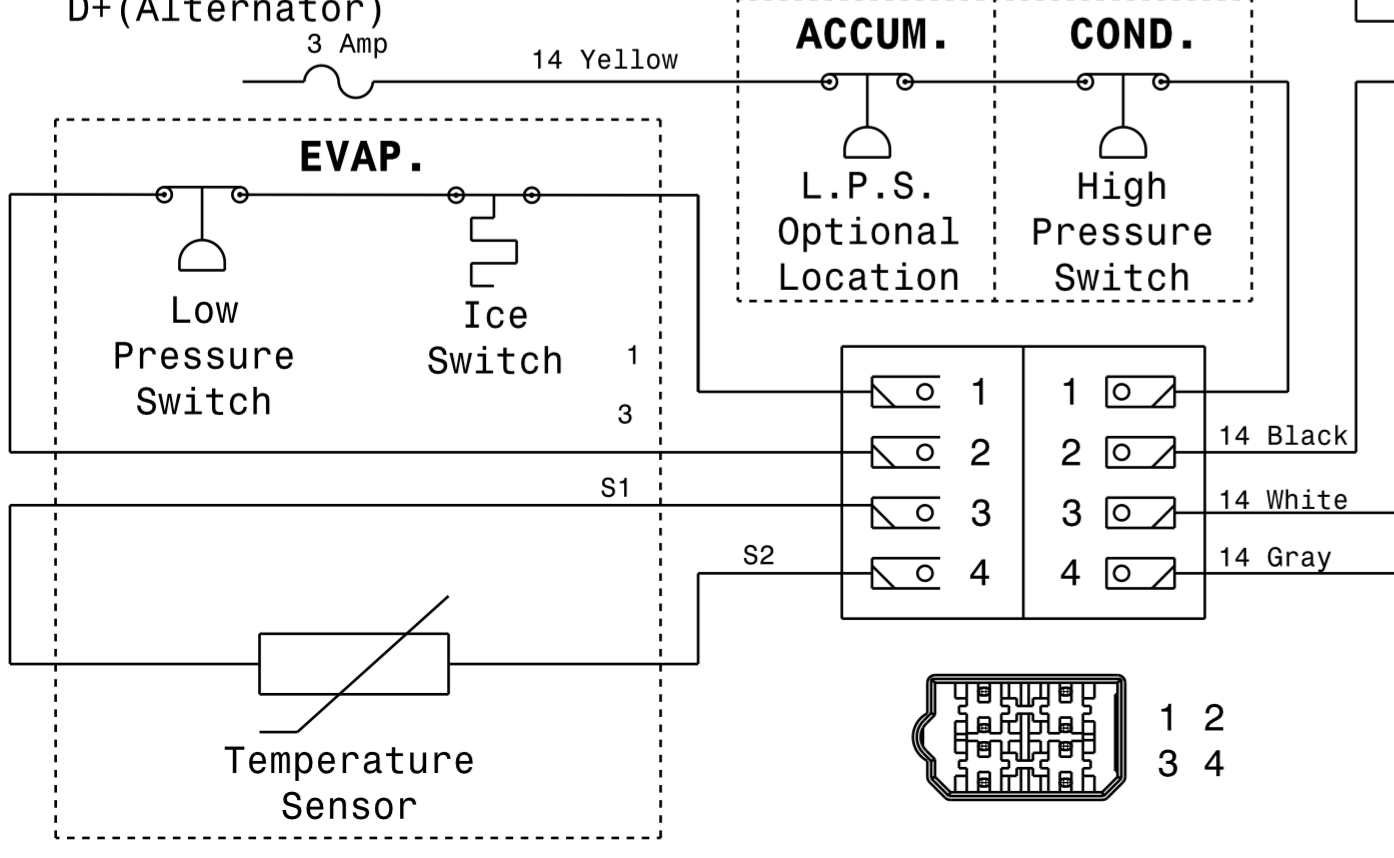

PART NAME				ARCTICSPHERE SPLIT SYSTEM WITH MANUAL CONTROL			
DATE	02/06/14	02/06/14	01/21/15	SCALE	FREE	DOC NO.	PART NO.
NAME	RAYY	JIMW	JIMW				20000027B-TAG
	DRAW	CHECK	APP			STATUS	
SPHEROS						SIZE	ISO A2
REPLACED BY PART-NO.				REPLACEMENT FOR PART-NO.			
PAGE				1 / 1			

Wire Maximum Wire Length @12 Volts DC
 Gauge 100 Amps
 4 37 Ft.
 2 60 Ft.
 1 76 Ft.
 Note: Maximum recommended wire lengths based on 1/2 volt maximum voltage drop.