

Bill of Materials Listing

TransArctic Canada Inc.

3/3/2021
Page 1 of 1

Product Number	Date	Description	Uof M	Weight	Yield		
Line	Qty	Component Prod#	Rev#	Description	Bin	Unit	
KMC62614	3/16/2012	2 Mt Kit, ISB, 6.7L, C2, 2 TM-21, '20				56.19	0
5	1	PAC23150		Pack, Carton, 23" x 15" x 10", 51 ECT		each	
10	1	BEL61816		Belt, 6gr, 1803mm (71.5") (5060715)		each	
20	1	BMC67182		1 Bkt, Main, Wldt, D-S, 6.7L, ISB, C2, '20		each	
25	1	BMZ00106		1 Bkt, Spacer PI, P/S Res, '20		each	
27	1	BMZ00107		2 Bkt, Support, Tran/lines		each	
30	1	FSP59286		0 Spacer, Fan, Pulley, ISB, 28.6mm (1.13")	Alley	each	
40	1	FSP62905		0 Spacer, Fan, Pulley, ISB, 29.05mm(1.14")		each	
45	2	4933235		Gasket, Connection,Throttle Body,Cummins	Alley	each	
50	1	PUL60089		0 Pulley, Frontside, STL, P6,89.4d (89174)		each	
60	1	PUL67006		0 Pulley, Crank, ADD-ON, Cum, ISB, 6.7, P6		each	
70	1	PUL80076		Pulley, Idler, Backside, P8, 74d (89101)		each	
75	1	SCD25730		0 Spacer, Step, Drl,25.7mm x 34.9o x10.08i	Alley	each	
82	1	SCD25408		0 Spacer, Col, Drl, 25.4mm x 25.4o x 8.33i	Alley	each	
84	1	SCD44212		0 Spacer, Col, Drl,44.48mm x 25.4o x 12.3i	Alley	each	
110	1	SLV17110		0 Sleeve, Pulley,S,16.9o x 22.23mm x 10.3i	Alley	each	
115	1	SPC25483		0 Spacer, Throttle Body, Offset,ISB,C2,'20	Alley	each	
120	1	TEN80002		Tenr, HD Spring, BackSide, CCW (89200A)		each	
130	1	KBC62614		2 Bag Kit, Fasteners, KMC62614/2014		each	

Bill of Materials Listing

TransArctic Canada Inc.

3/3/2021
Page 1 of 1

Product Number	Date	Description	Uof M	Weight	Yield	
Line	Qty	Component Prod#	Rev#	Bin	Unit	
KBC62614	11/6/2012	2 Bag Kit, Fasteners, KMC62614/2014			5.51	0
1	1	BTS10001			each	
3	4	BTS06015			each	
4	1	BTQ06200			each	
7	1	BTC06030			each	
9	1	BTC08050			each	
10	12	BTC08100			each	
20	3	BTC10045			each	
30	4	BSD00001			each	
35	1	BTC10080			each	
40	1	BTC10090			each	
50	6	BTC10110			each	
70	1	BTC12140			each	
75	2	BTC12030			each	
80	6	CSS12090			each	
85	1	NTA06000			each	
90	5	NTA10000			each	
92	1	NTS10254			each	
95	1	WFA06000			each	
100	12	WFA08000			each	
110	9	WFA10000			each	
120	3	WFA12000			each	
130	6	WFS12002			each	
135	1	WLA06000			each	
140	12	WLA08000			each	
150	9	WLA10000			each	
160	3	WLA12000			each	

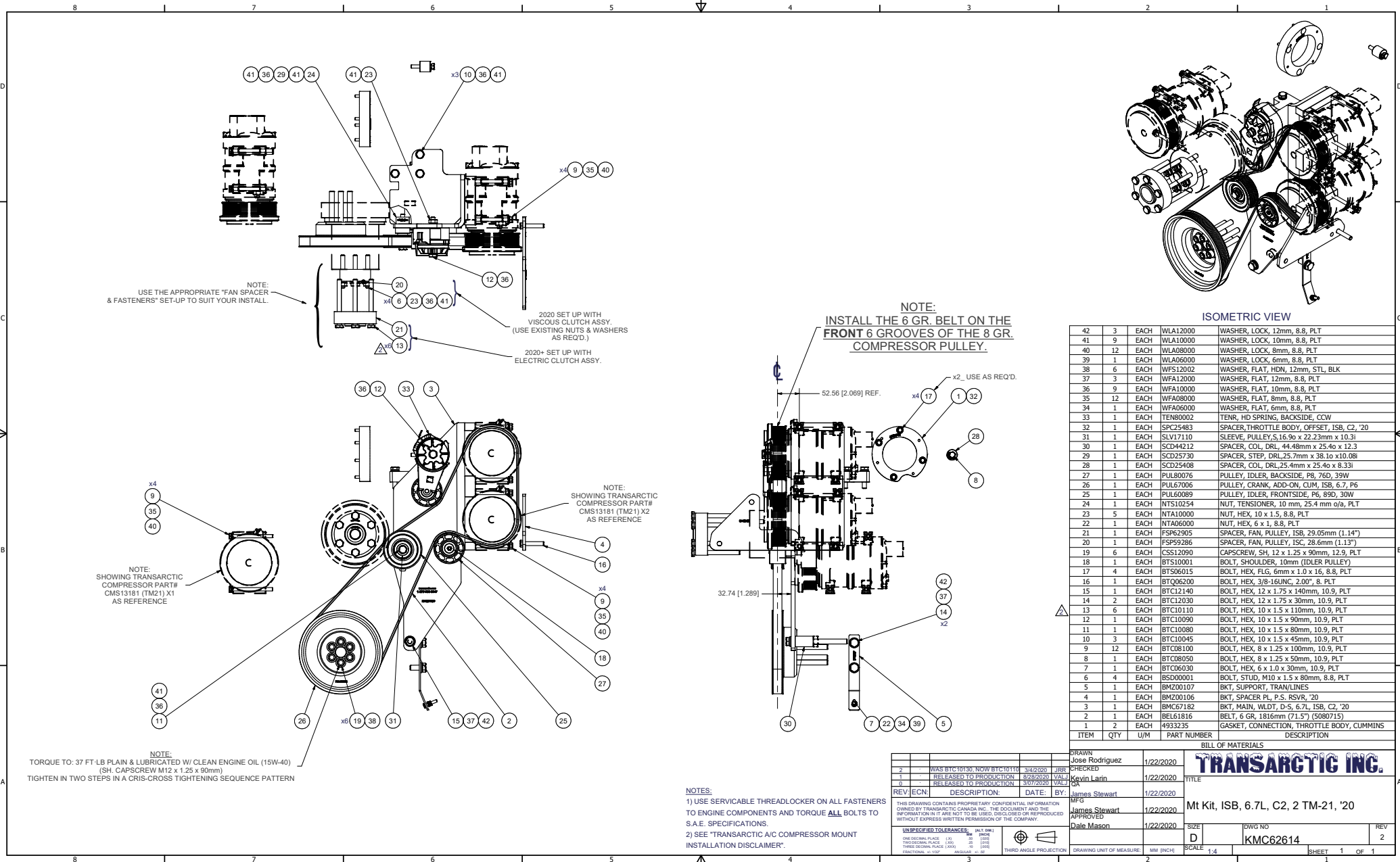

ITEM	QTY	U/M	PART NUMBER	DESCRIPTION
42	3	EACH	WLA12000	WASHER, LOCK, 12mm, 8.8, PLT
41	9	EACH	WLA10000	WASHER, LOCK, 10mm, 8.8, PLT
40	12	EACH	WLA08000	WASHER, LOCK, 8mm, 8.8, PLT
39	1	EACH	WLA06000	WASHER, LOCK, 6mm, 8.8, PLT
38	6	EACH	WFS12002	WASHER, FLAT, HDN, 12mm, STL, BLK
37	3	EACH	WFA12000	WASHER, FLAT, 12mm, 8.8, PLT
36	9	EACH	WFA10000	WASHER, FLAT, 10mm, 8.8, PLT
35	12	EACH	WFA08000	WASHER, FLAT, 8mm, 8.8, PLT
34	1	EACH	WFA06000	WASHER, FLAT, 6mm, 8.8, PLT
33	1	EACH	TEN80002	TENR, HD SPRING, BACKSIDE, CCW
32	1	EACH	SPC25483	SPACER, THROTTLE BODY, OFFSET, ISB, C2, '20
31	1	EACH	SLV17110	SLEEVE, PULLEY, 5,16.90 x 22.23mm x 10.31
30	1	EACH	SCD44212	SPACER, COL, DRL, 44.48mm x 25.40 x 12.3
29	1	EACH	SCD25730	SPACER, STEP, DRL, 25.7mm x 38.10 x 10.081
28	1	EACH	SCD25408	SPACER, COL, DRL, 25.4mm x 25.40 x 8.331
27	1	EACH	PUL80076	PULLEY, IDLER, BACKSIDE, P8, 760, 39W
26	1	EACH	PUL67006	PULLEY, CRANK, ADD-ON, CLM, ISB, 6.7, P6
25	1	EACH	PUL60089	PULLEY, IDLER, FRONTSIDE, P6, 890, 30W
24	1	EACH	NTS10254	NUT, TENSIONER, 10 mm, 25.4 mm o/a, PLT
23	5	EACH	NTA10000	NUT, HEX, 10 x 1.5, 8.8, PLT
22	1	EACH	NTA06000	NUT, HEX, 6 x 1, 8.8, PLT
21	1	EACH	FSP62905	SPACER, FAN, PULLEY, ISB, 29.05mm (1.14")
20	1	EACH	FSP9286	SPACER, FAN, PULLEY, ISC, 28.6mm (1.13")
19	6	EACH	CSS12090	CAPSCREW, SH, 12 x 1.25 x 90mm, 12.9, PLT
18	1	EACH	BTS10081	BOLT, SHOULDER, 10mm (IDLER PULLEY)
17	4	EACH	BTS06015	BOLT, HEX, FLG, 6mm x 1.0 x 1.6, 8.8, PLT
16	1	EACH	BTQ06200	BOLT, HEX, 3/8-16UNC, 2.00", 8, PLT
15	1	EACH	BTC12140	BOLT, HEX, 12 x 1.75 x 140mm, 10.9, PLT
14	2	EACH	BTC12030	BOLT, HEX, 12 x 1.75 x 30mm, 10.9, PLT
13	6	EACH	BTC10110	BOLT, HEX, 10 x 1.5 x 110mm, 10.9, PLT
12	1	EACH	BTC10090	BOLT, HEX, 10 x 1.5 x 90mm, 10.9, PLT
11	1	EACH	BTC10080	BOLT, HEX, 10 x 1.5 x 80mm, 10.9, PLT
10	3	EACH	BTC10045	BOLT, HEX, 10 x 1.5 x 45mm, 10.9, PLT
9	12	EACH	BTC08100	BOLT, HEX, 8 x 1.25 x 100mm, 10.9, PLT
8	1	EACH	BTC08050	BOLT, HEX, 8 x 1.25 x 50mm, 10.9, PLT
7	1	EACH	BTC06030	BOLT, HEX, 6 x 1.0 x 30mm, 10.9, PLT
6	4	EACH	BSD00001	BOLT, STUD, M10 x 1.5 x 80mm, 8.8, PLT
5	1	EACH	BMZ00107	BKT, SUPPORT, TRAN/LINES
4	1	EACH	BMZ00106	BKT, SPACER PL, P.S. RSVR, '20
3	1	EACH	BMC67182	BKT, MAIN, WLDT, D-S, 6.7L, ISB, C2, '20
2	1	EACH	BEL61816	BELT, 6 GR, 1816mm (71.5") (5080715)
1	2	EACH	4933235	GASKET, CONNECTION, THROTTLE BODY, CUMMINS

BILL OF MATERIALS				
2	WAS BTC1010; NOW BTC1010	3/4/2020	JRR	
1	RELEASED TO PRODUCTION	3/07/2020	VAL	
REV	ECN	DESCRIPTION	DATE	BY
0			1/22/2020	James Stewart
1			1/22/2020	James Stewart
2			1/22/2020	Dale Mason

DRAWN		Jose Rodriguez	1/22/2020	CHECKED	Kevin Latin	1/22/2020
DATE		1/22/2020	BY	DATE	1/22/2020	BY
APPROVED		James Stewart	1/22/2020	APPROVED	Dale Mason	1/22/2020
UNSPECIFIED TOLERANCES:		ALL DIMS	FINISH			
ONE DECIMAL PLACE (X1)	0.1	THREE DECIMAL PLACE (X100)	0.001			
FRACTIONAL (X16)	1/16	FRACTIONAL (X32)	1/32			
THIRD ANGLE PROJECTION						
DRAWING UNIT OF MEASURE		MM (INCH)	SCALE	1:4	DWG NO	KMC62614
SHEET		1	OF	1	REV	2

NOTES:
1) USE SERVICABLE THREADLOCKER ON ALL FASTENERS TO ENGINE COMPONENTS AND TORQUE ALL BOLTS TO S.A.E. SPECIFICATIONS.
2) SEE "TRANSARCTIC A/C COMPRESSOR MOUNT INSTALLATION DISCLAIMER".

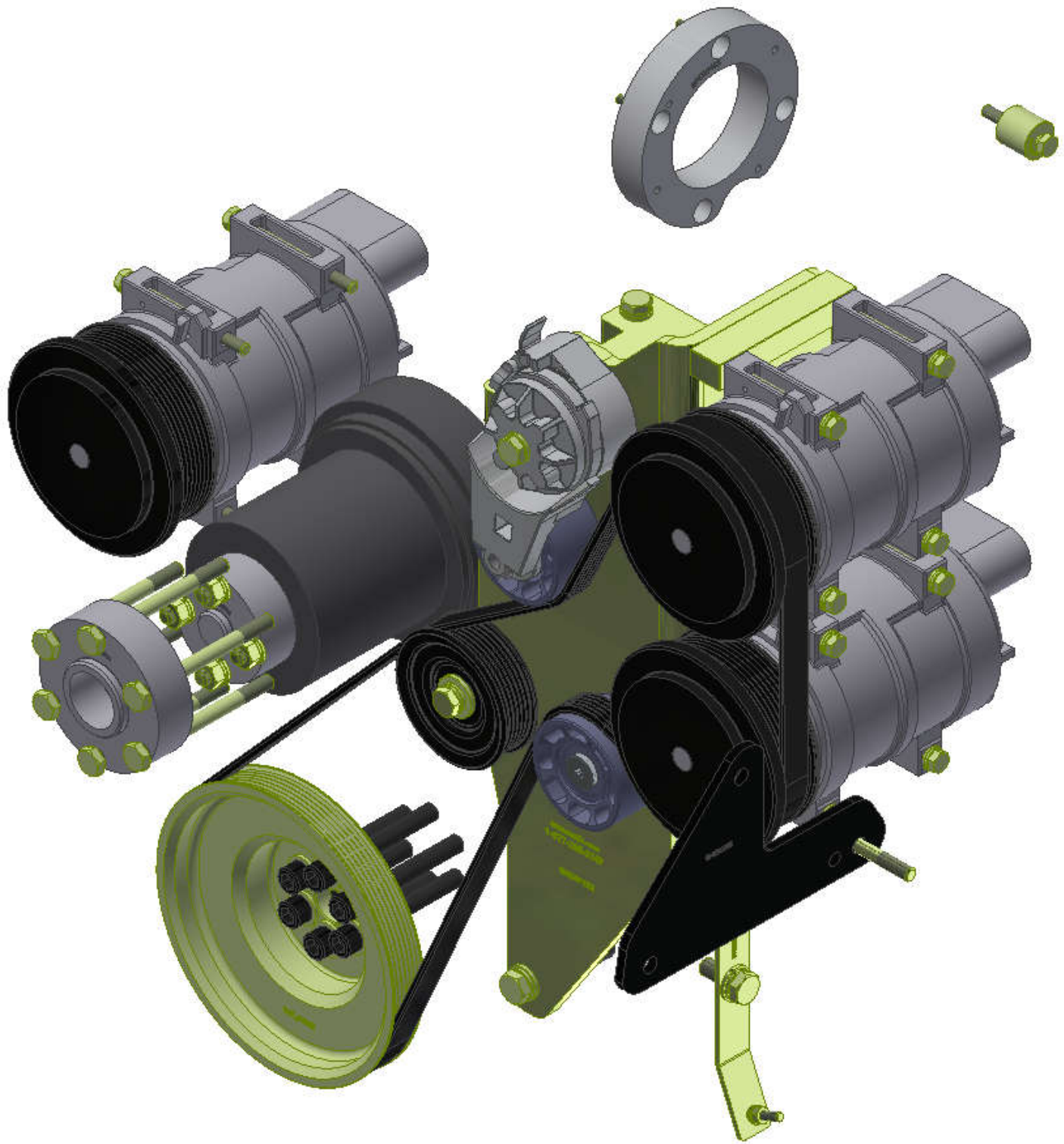

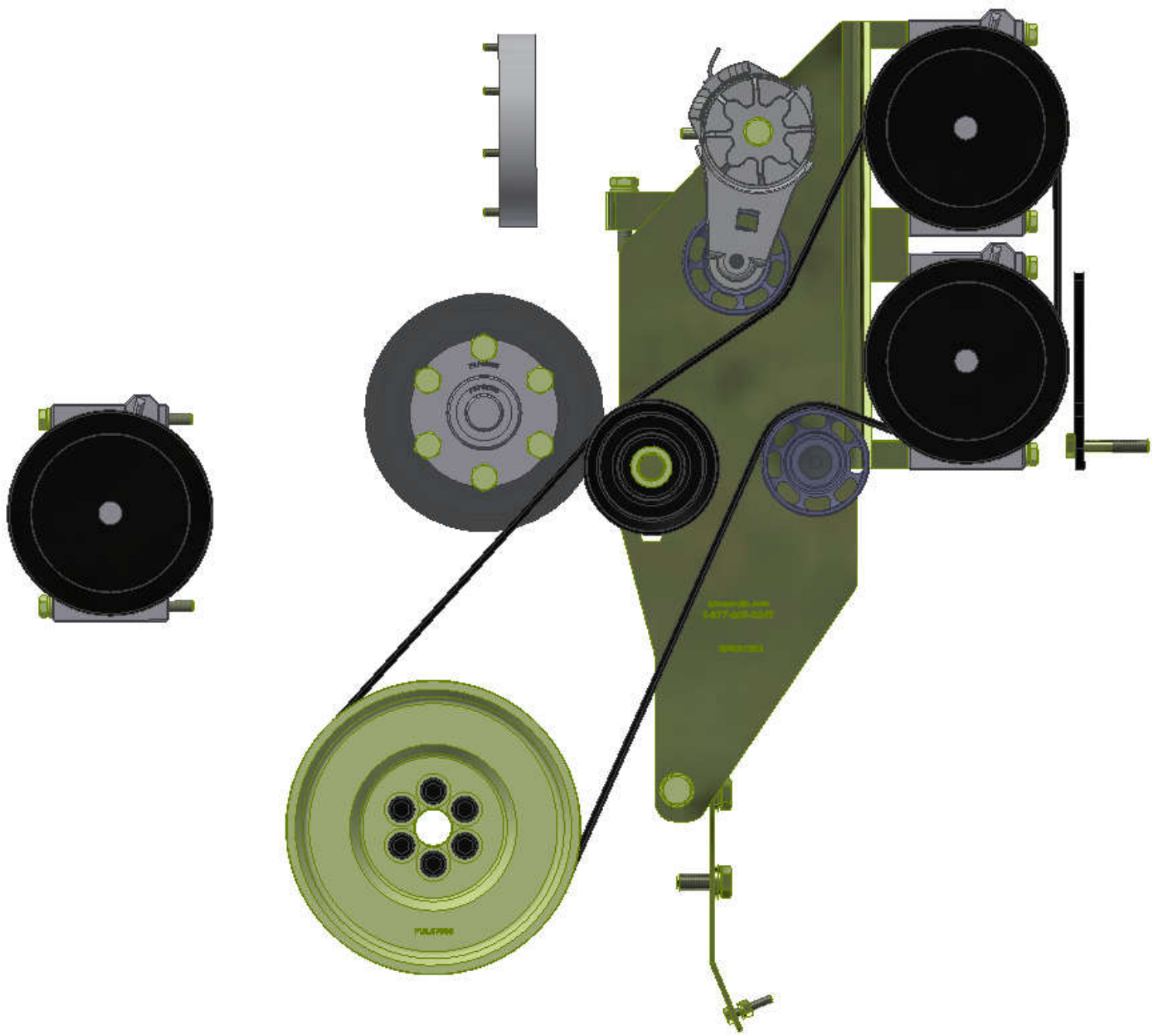

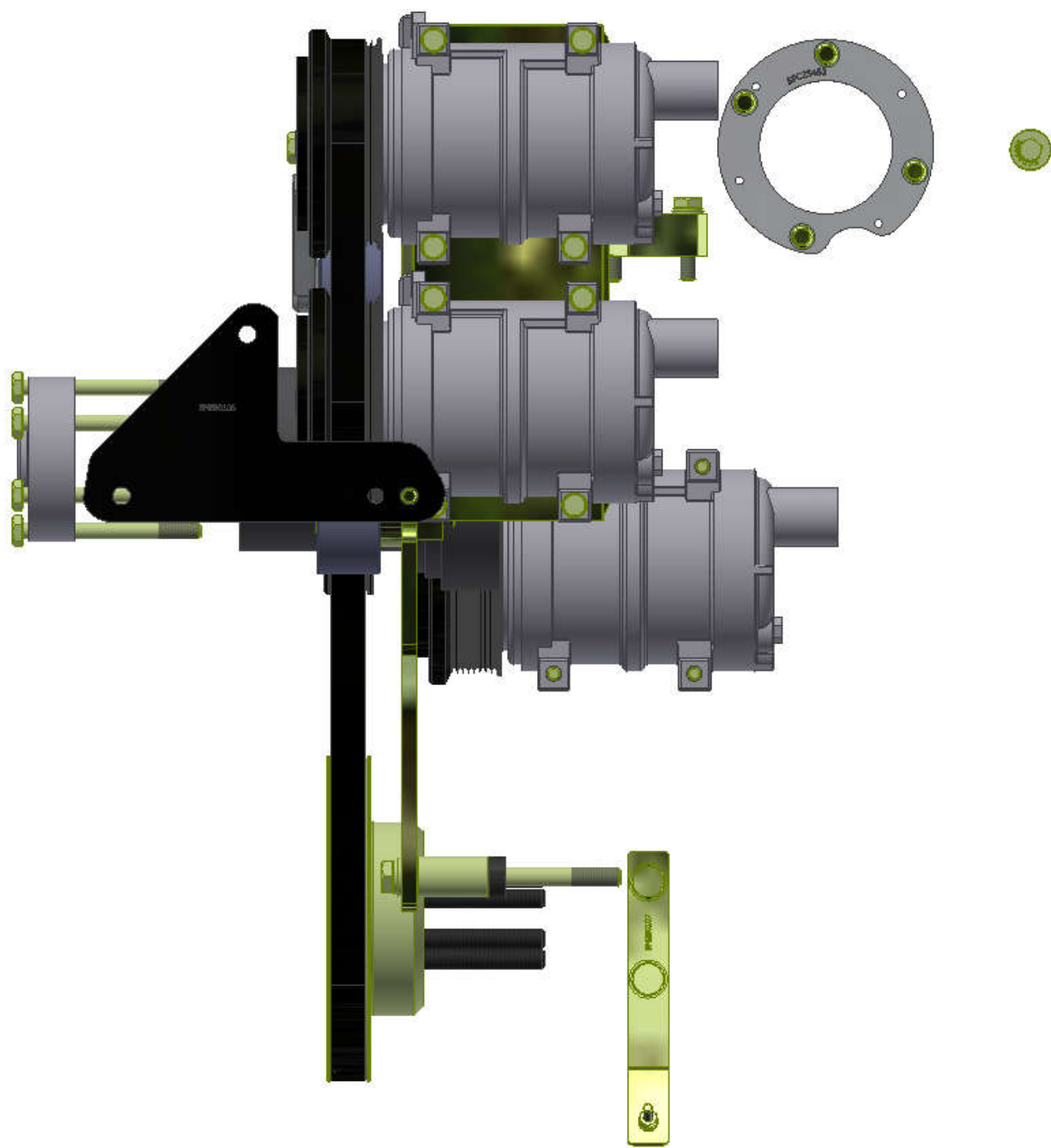

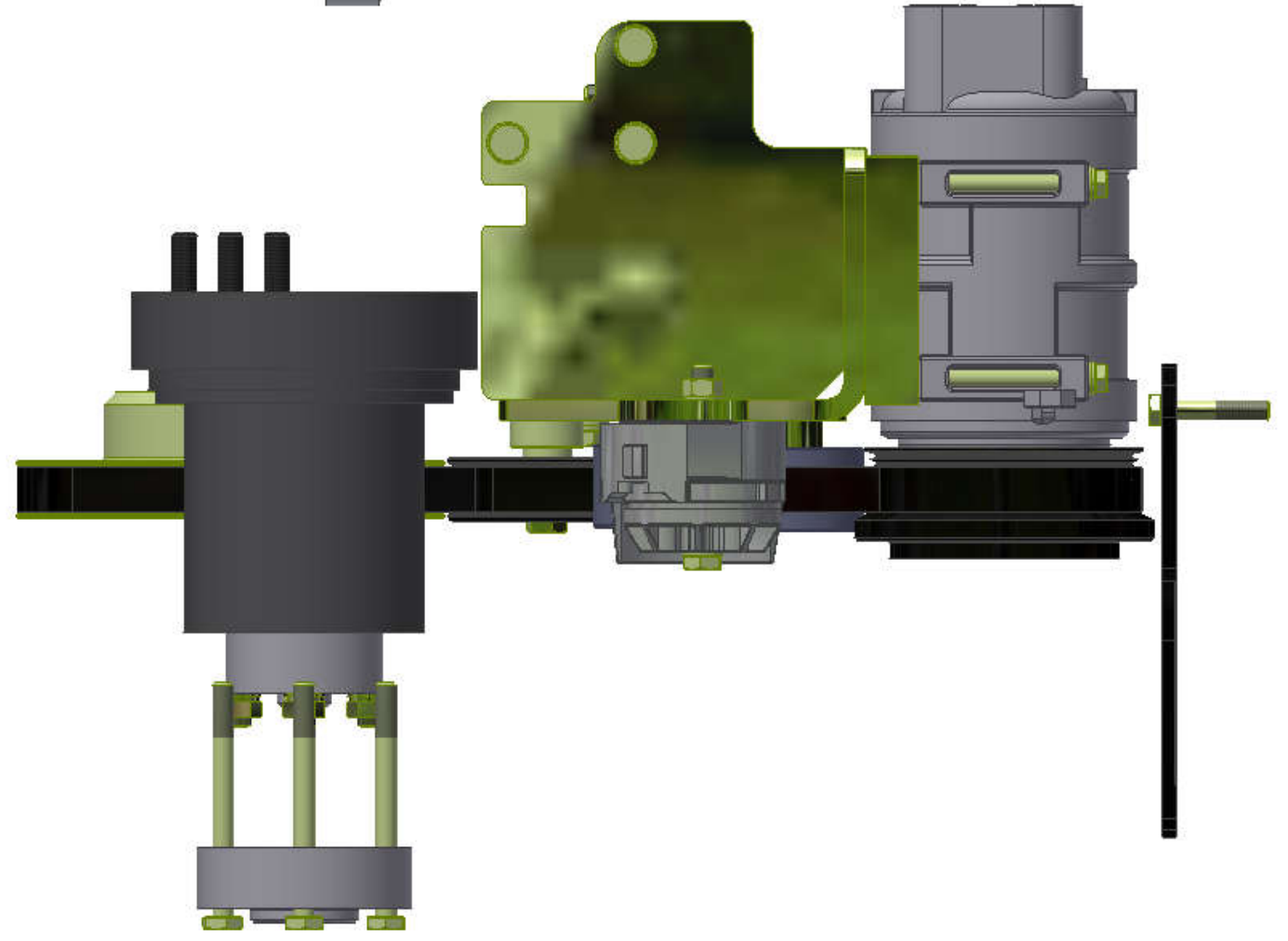
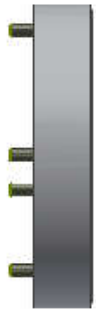
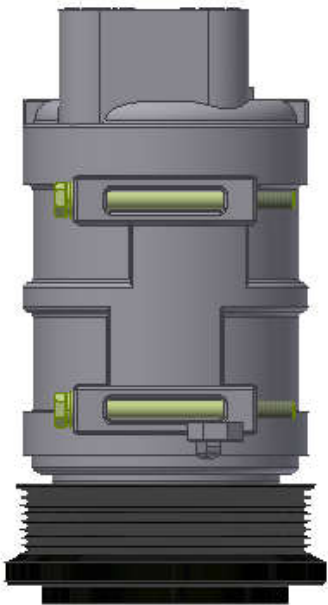

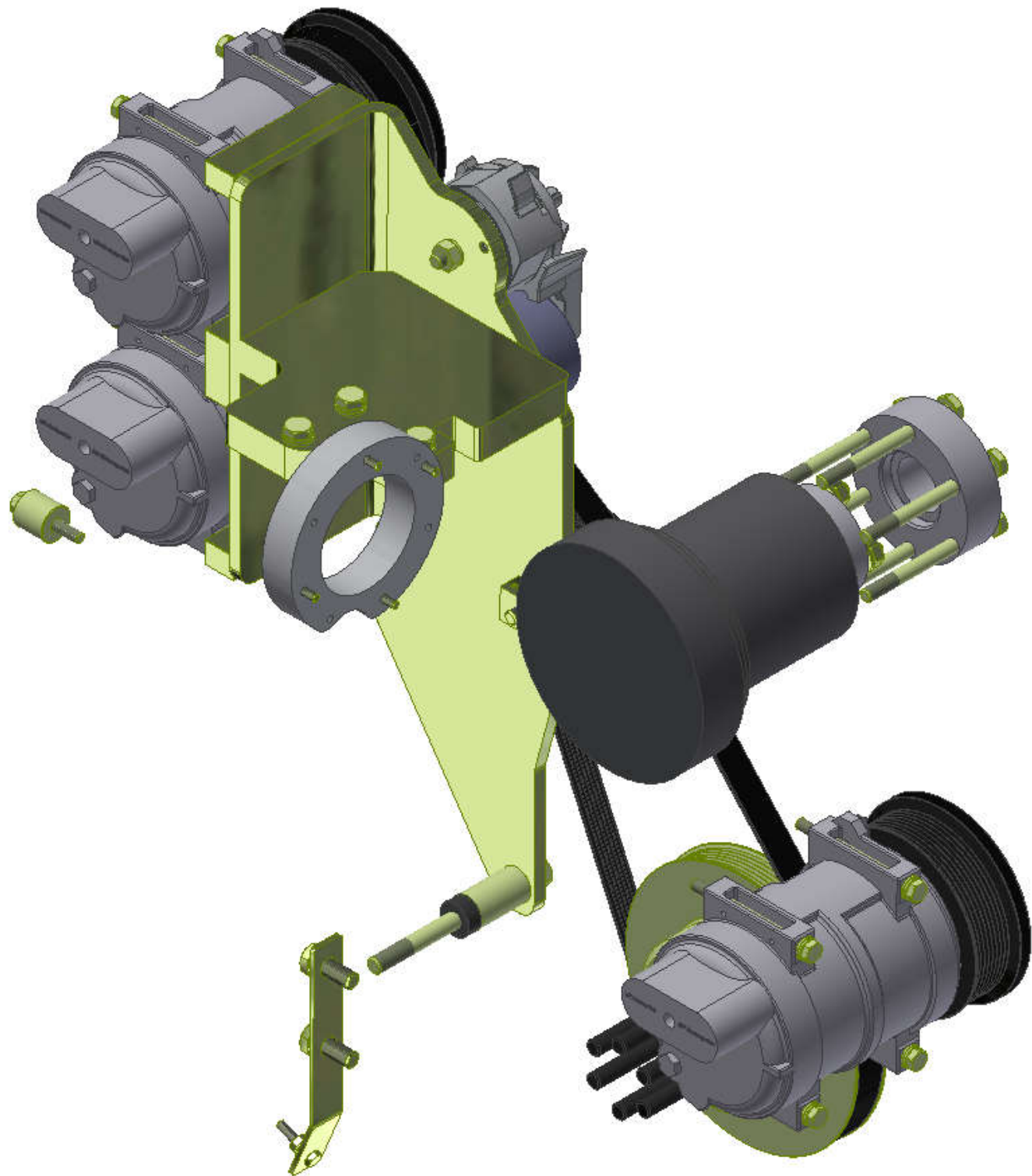

TransArctic A/C Compressor Mount Installation Disclaimer

All compressor mounts should be installed by qualified and trained personnel using proper tools and equipment in safe working conditions following industry standard guidelines for motor vehicle service and repair.

The installer of any compressor mount purchased from TransArctic must undertake all responsibility of issues arising from that compressor bracket being installed on any vehicle. As well as insure that a **proper and sufficient ground** is established between the compressors' clutches and the vehicle's engine. Mount functionality, operation and durability can all be compromised by an incompetent installation.

Due to the many different situations, parameters and application criteria, which are beyond the compressor mount manufacturer's control, TransArctic does not warrant design, durability, or operational functionality of any compressor mount improperly installed by another party.

With no implied guarantees it is the mount installer's strict responsibility to determine safety and functionality, of the compressor mount, at the time of installation.

Please contact TransArctic with any issue arising from installation so we may better improve the product. If you have any reservations about the compressor mount integrity contact TransArctic immediately at 1-877-COLD-AIR.

Mark OEM tensioner location

Install Kit

Check for Interferences

Check to ensure that the proper OEM tensioner orientation is maintained

Run engine with A/C system engaged for at least 10 minutes to run in belt

Check OEM tensioner orientation and adjust as required

Responsabilidad limitada de TransArctic en la instalación del soporte del compresor

Todos los soportes de los compresores deben ser instalados por personas calificadas y entrenadas, usando para ello los equipos y herramientas necesarios para esta labor en buenas condiciones y según las normas y guías para el servicio y/o reparación de motores de vehículos.

El instalador de los soportes comprados en TransArctic asume toda la responsabilidad de cualquier problema que surja en el soporte del compresor al vehículo; de igual manera es responsable que el cable a tierra sea conectado entre el embrague del compresor y el motor del vehículo.

Se advierte que el buen funcionamiento y la durabilidad del soporte pueden ser comprometidos por defectos en su instalación.

Debido a las diversas situaciones que se puedan presentar fuera del control del fabricante, TransArctic no garantiza el diseño, la durabilidad o el correcto funcionamiento de cualquier equipo inapropiadamente instalado por terceros.

Esta sobreentendido que el Instalador del montaje del compresor es estrictamente responsable de la seguridad y funcionamiento del equipo en el momento de la instalación.

Si tuviera algún problema o duda acerca de la instalación del soporte del compresor pongase en contacto inmediatamente con TransArctic al teléfono 1-877-COLD-AIR de modo que podamos mejorar nuestro producto.

Note la ubicación del medidor de tensión OEM

Instale el equipo

Controlar si hay interferencias.

Asegurese que el medidor de tensión mantenga la orientación justa.

Encienda el motor por lo menos 10 minutos con el sistema A/C enganchado para que la correa corra

Controle la orientación justa del medidor de tensión y ajuste a las condiciones requeridas del fabricante