

Bill of Materials Listing

TransArctic Canada Inc.

3/16/2012
Page 1 of 1

Product Number		Description	Bin	Date	Weight	Uof M	Yield
Line	Component Prod#	Description		Unit	Qty		
KMC84162		Mt Kit, ISC, D3RE 05G, 2B, 8" Crank, '10		4/9/2010	241.61		0
0	BEL22311	Belt, B gr, 2311mm (91") (BX88)		each	2		
10	BMC83047	Bkt, Brace, Vert, RR, Bumper, ISC, D3		each	1		
20	BMC83070	Bkt, Sup, Weldm't, ISC, D3RE, '10		each	1		
30	BMC83051	Bkt, Side, Extention, Plate		each	2		
40	BMC83052	Bkt, Main, RR Plate, MFDT, RE300		each	1		
50	BMC83053	Bkt, Diag, Brace RR, MFDT, RE300		each	1		
60	BMC83054	Bkt, Main, Idler, Weldm't, RE300		each	1		
70	BMC83057	Bkt, Main, Frt Pl, MFDT, RE300		each	1		
80	BMC83058	Bkt, Cover, Light Pl, MF DT, RE300		each	1		
90	BMC83059	Bkt, Diag, Brace Frt, MF DT, RE300		each	1		
95	BMC83074	Bkt, Relay, ISC, D3RE, 2010		each	1		
100	BMN80008	Vibration Isolator, Bar, 16.50 x 2 x 1.50		each	2		
102	BMC83075	Bkt, PI, Exhaust, Adapter, D3RE, '10		each	1		
110	BMN80009	Bkt, Main, Base Pl, IC, RE300		each	1		
120	BMN80010	Bkt, Main, Slide, Assy, 05G, IC, RE300		each	1		
130	BMN80024	Bkt, Comp, FRT, Z, IC, RE300		each	1		
140	BMN80025	Bkt, Back, PL, Slide, IC, RE300		each	1		
150	KAC84161	Alt. Kit, 24V, ISC, BBRE, '07		each	1		
160	PUA05012	Pulley, Assy, Idler, B/BX gr, 5", STL, Plt		each	1		
170	PUL80074	Pulley, Idler, B/S, Wide, 76d (89102)		each	1		
180	PUL89322	Pulley, Crank, ADD-ON, Combo, ISL, 2B/3V		each	1		
190	SCD29213	Spacer, Col, Drl, 29.21mm x 25.4o x 12.7i		each	2		
195	SCD37012	Spacer, Col, Drl, 37 mm x 25.4o x 12.3i		each	1		
200	SCD41012	Spacer, Col, Drl, 41 mm x 25.4o x 12.3i		each	1		
203	SLV17012	Sleeve, Pulley, 16.9o x 22.23mm x 12.32i		each	2		
205	TUS04095	Tube, Stl, Exh, 4" o.d., D3RE, ISC, '10		each	1		
206	FTS06006	Ftg, Pipe, Adapter, Bulkhead, 1/8x1-1/2		each	1		
207	FTS06007	Ftg, Pipe, Elbow, 90 DEG, Male		each	2		
208	TUP00014	Ftg, Tubing, Plastic, 1/4 OD, Black		feet	4		
210	HOA04083	Hose, Flex, CAC, 4.0d x 8.0, 3 ring		each	1		
220	CLP04000	Clamp, T bolt, Spring, 4", CAC		each	2		
230	KBC84162	Bag Kit, Fasteners, KMC84162		each	1		

Bill of Materials Listing

TransArctic Canada Inc.

3/16/2012
Page 1 of 1

Product Number		Description	Bin	Date	Weight	Uof M	Yield
Line	Component Prod#	Description		Unit	Qty		
KBC84162		Bag Kit, Fasteners, KMC84162		4/12/2010	4.68		0
0	BTC08035	Bolt, Hex, 8 x 1.25 x 35mm, 10.9, Plt,FT		each	4		
5	BTC10040	Bolt, Hex, 10 x 1.5 x 40mm, 10.9, Plt,FT		each	4		
10	BTC12035	Bolt, Hex, 12 x 1.75 x 35mm, 10.9,Plt,FT		each	1		
20	BTC12040	Bolt, Hex, 12 x 1.75 x 40mm, 10.9,Plt,FT		each	4		
30	BTC12050	Bolt, Hex, 12 x 1.75 x 50mm, 10.9,Plt		each	2		
40	BTC12100	Bolt, Hex, 12 x 1.75 x 100mm, 10.9, Plt		each	2		
50	BTP08653	Bolt, Hex, 1/2-13unc, 6.5", 5, Plt, FT		each	1		
60	BTQ06150	Bolt, Hex, 3/8-16unc, 1.50", 8, Plt		each	2		
65	BTQ05075	Bolt, Hex, 5/16-18unc, .75", 8, Plt		each	4		
70	BTQ08126	Bolt, Hex, 1/2-20unf, 1.25", 8, Plt		each	10		
80	BTQ08151	Bolt, Hex, 1/2-20unf, 1.5", 8, Plt		each	2		
90	NTA12000	Nut, Hex, 12 x 1.75, 8.8, Plt		each	9		
100	NTP07000	Nut, Hex, 7/16-14unc, 5, Plt		each	4		
101	SCP03075	Screw, PH, PD, SDT, #10-16 x .75, ST,Plt		each	3		
102	WFA08000	Washer, Flat, 8mm, 8.8, Plt		each	4		
105	WFA10000	Washer, Flat, 10mm, 8.8, Plt		each	4		
110	WFA12000	Washer, Flat, 12mm, 8.8, Plt		each	16		
115	WFN05000	Washer, Flat, 5/16", 2, Plt		each	4		
120	WFN06000	Washer, Flat, 3/8", 2, Plt		each	2		
130	WFN07000	Washer, Flat, 7/16", 2, Plt		each	4		
140	WFO08000	Washer, Flat, 1/2", 8, Plt		each	12		
145	WLA08000	Washer, Lock, 8mm, 8.8, Plt		each	4		
150	WLA12000	Washer, Lock, 12mm, 8.8, Plt		each	9		
153	WLA10000	Washer, Lock, 10mm, 8.8, Plt		each	4		
155	WLP05000	Washer, Lock, 5/16", 5, Plt		each	4		
160	WLP06000	Washer, Lock, 3/8", 5, Plt		each	2		
170	WLP07000	Washer, Lock, 7/16", 5, Plt		each	4		
180	WLP08000	Washer, Lock, 1/2", 5, Plt		each	13		

Bill of Materials Listing

TransArctic Canada Inc.

4/21/2010
Page 1 of 1

Product Number	Description	Date	Weight	Uof M	Yield
Line Component Prod#	Description	Bin Unit	Qty		
KAC84161	Alt. Kit, 24V, ISC, BBRE, '07		10/18/2007	11.77	0
10 BEL81257	Belt, 8gr, 1257mm (49.5") (5080495)		each	1	
20 BMC83015	Bkt, Alt, Weldmt, ISC, BBRE, '07		each	1	
30 PUL83008	Pulley, Fan, Add-on, Cum, ISC, 8.3, 8gr		each	1	
40 PUL80064	Pulley,ALT,Frontside,P8,63.5d (3972808)		each	1	
50 TEN80002	Tenr, HD Spring, BackSide, CCW (89200A)		each	1	
60 KBA84161	Bag Kit, Fasteners, KAC84161		each	1	

Bill of Materials Listing

TransArctic Canada Inc.

4/27/2010
Page 1 of 1

Product Number	Description	Date	Weight	Uof M	Yield
Line Component Prod#	Description	Bin Unit	Qty		
KBA84161	Bag Kit, Fasteners, KAC84161		10/19/2007	1.07	0
10 BTC10090	Bolt, Hex, 10 x 1.5 x 90mm, 10.9, Plt		each	1	
20 BTC10055	Bolt, Hex, 10 x 1.5 x 55mm, 10.9, Plt,FT		each	3	
25 CSS10055	Capscrew, SH, 10 x 1.5 x 55mm, 12.9,Plt		each	1	
30 BTQ08653	Bolt, Hex, 1/2-13unc, 6.5", 8, Plt		each	1	
40 BTQ08150	Bolt, Hex, 1/2-13unc, 1.5", 8, Plt		each	1	
50 NTA10000	Nut, Hex, 10 x 1.5, 8.8, Plt		each	1	
60 NTP08000	Nut, Hex, 1/2-13unc, 5, Plt		each	1	
70 WFA10000	Washer, Flat, 10mm, 8.8, Plt		each	4	
80 WFAQ08000	Washer, Flat, 1/2", 8, Plt		each	3	
90 WLA10000	Washer, Lock, 10mm, 8.8, Plt		each	4	
100 WLQ08000	Washer, Lock, 1/2", 8, Plt		each	2	

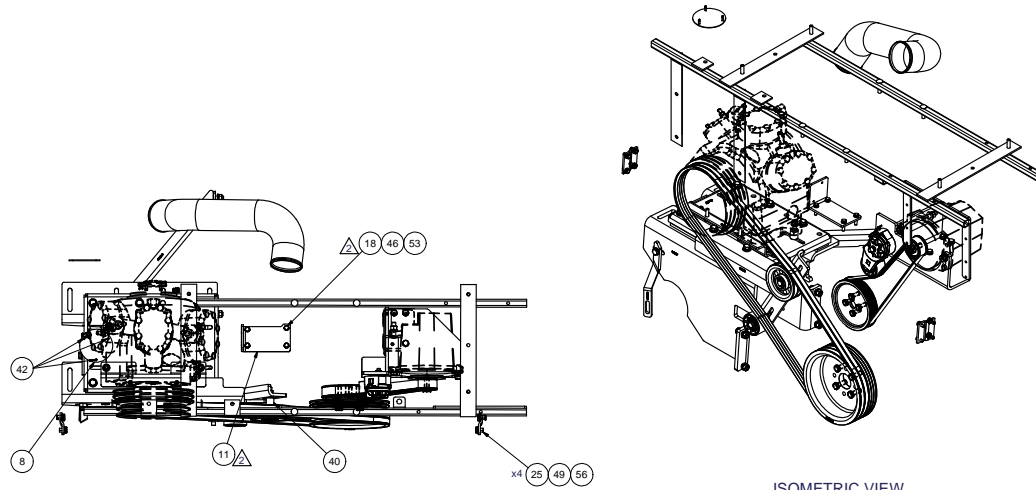

ISOMETRIC VIEW

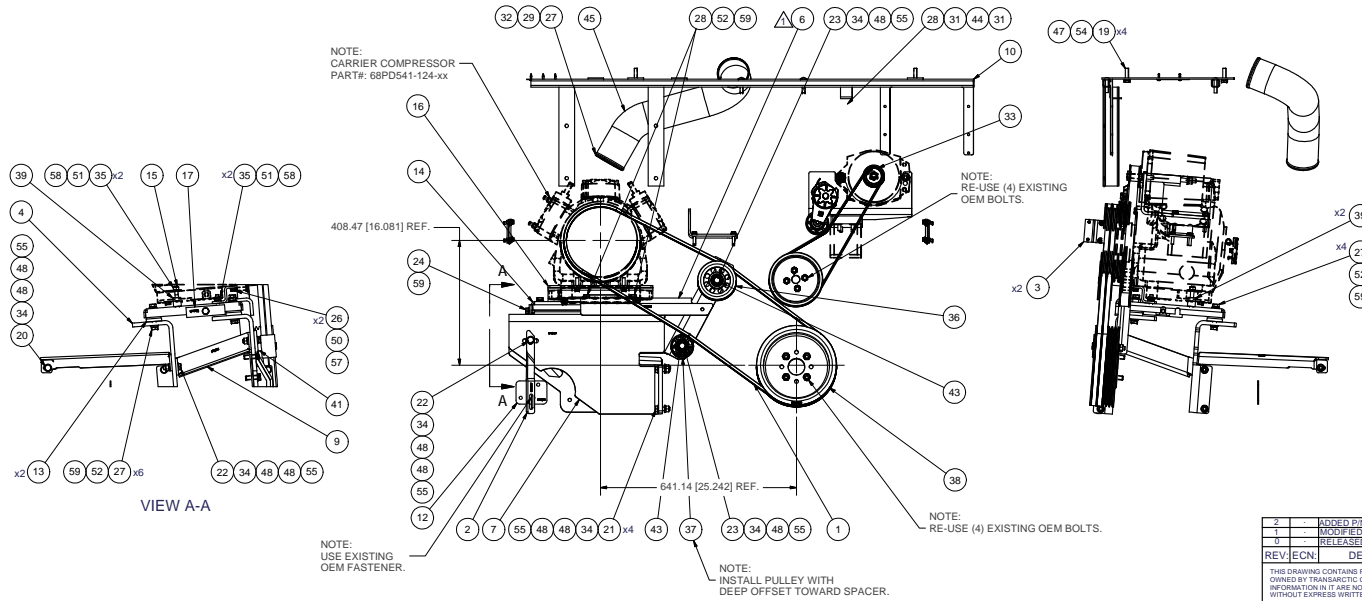

NOTE:
CARRIER COMPRESSOR
PART#: 68PD541-124-xx

NOTE:
RE-USE (4) EXISTING
OEM BOLTS.

NOTE:
RE-USE (4) EXISTING OEM BOLTS.

NOTE:
USE EXISTING
OEM FASTENER.

NOTE:
INSTALL PULLEY WITH
DEEP OFFSET TOWARD SPACER.

NOTES:

- 1) USE SERVICABLE THREADLOCKER ON ALL FASTENERS TO ENGINE COMPONENTS AND TORQUE ALL BOLTS TO S.A.E. SPECIFICATIONS.
- 2) SEE 'TRANSARCTIC A/C COMPRESSOR MOUNT INSTALLATION DISCLAIMER'.

ITEM	QTY	U/M	PART NUMBER	DESCRIPTION
59	13	EACH	WLP08000	WASHER, LOCK, 1/2", 5, PLT
58	4	EACH	WLP07000	WASHER, LOCK, 7/16", 5, PLT
57	2	EACH	WLP06000	WASHER, LOCK, 3/8", 5, PLT
56	4	EACH	WLP05000	WASHER, LOCK, 5/16", 5, PLT
55	9	EACH	WLA12000	WASHER, LOCK, 12mm, 8.8, PLT
54	4	EACH	WLA10000	WASHER, LOCK, 10mm, 8.8, PLT
53	4	EACH	WLA08000	WASHER, LOCK, 8mm, 8.8, PLT
52	12	EACH	WFO08000	WASHER, FLAT, 1/2", 8, PLT
51	4	EACH	WFO07000	WASHER, FLAT, 7/16", 2, PLT
50	2	EACH	WFO06000	WASHER, FLAT, 3/8", 2, PLT
49	4	EACH	WFO05000	WASHER, FLAT, 5/16", 2, PLT
48	16	EACH	WFA12000	WASHER, FLAT, 12mm, 8.8, PLT
47	4	EACH	WFA10000	WASHER, FLAT, 10mm, 8.8, PLT
46	4	EACH	WFA08000	WASHER, FLAT, 8mm, 8.8, PLT
45	1	EACH	TUS04095	TUBE, STL, EXH, 4" O.D., D3RE, ISC, 10
44	1	FEET	PUL00014	FTG. TUBING, PLASTIC, 1/4" O.D., BLACK
43	2	EACH	SLV17012	SLEEVE, PULLEY, 16.90 x 22.23 mm x12.19i
42	3	EACH	SCP03075	SCREW, PH, SDT, #10-16 x .75, ST, PLT
41	1	EACH	SCD41012	SPACER, COL, DRL, 41mm x 25.40 x 12.3i
40	1	EACH	SCD37012	SPACER, COL, DRL, 37mm x 25.40 x 12.3i
39	2	EACH	SCD29213	SPACER, COL, DRL, 29.21mm x 25.40 x 12.7i
38	1	EACH	PUL93222	PULLEY, CRANK, ADD-ON, COMBO, ISL, 28/3V
37	1	EACH	PUL80074	PULLEY, IDLER, BACKSIDE, P8, 74D, 46.27W
36	1	EACH	PLA05012	PULLEY, ASSY, IDLER, B/BX gr, 5" STL, PLT
35	4	EACH	NTP07000	NUT, HEX, 7/16-14UNC, 5, PLT
34	9	EACH	NTA12000	NUT, HEX, 12 x 1.75, 8.8, PLT
33	1	EACH	KAC84161	ALT. KIT, 24V, ISC, BBRE, '07
32	1	EACH	HOA04083	HOSE, FLEX, CAC, 4.0d x 8.0, 3 RING
31	2	EACH	FIS06007	FTG. PIPE, ELBOW, 90 DEG, MALE
30	1	EACH	FIS06006	FTG. PIPE, ADAPTER, BULKHEAD, 1/8x1-1/2
29	2	EACH	CLP04000	CLAMP, 1 BOLT, SPRING, 4", CAC
28	2	EACH	BTQ08151	BOLT, HEX, 1/2-20UNF x 1.50, 8, PLT
27	10	EACH	BTQ08126	BOLT, HEX, 1/2-20UNF x 1.25, 8, PLT
26	2	EACH	BTQ06150	BOLT, HEX, 3/8-16UNC, 1.50", 8, PLT
25	4	EACH	BTQ05075	BOLT, HEX, 5/16-18UNC, .75", 8, PLT
24	1	EACH	BTP08653	BOLT, HEX, 1/2-13UNC x 6.50, 5, PLT, FT
23	2	EACH	BTC12100	BOLT, HEX, 12 x 1.75 x 100mm, 10.9, PLT
22	2	EACH	BTC12050	BOLT, HEX, 12 x 1.75 x 50mm, 10.9, PLT
21	4	EACH	BTC12040	BOLT, HEX, 12 x 1.75 x 40mm, 10.9, PLT
20	1	EACH	BTC12035	BOLT, HEX, 12 x 1.75 x 35mm, 10.9, PLT
19	4	EACH	BTC10040	BOLT, HEX, 10 x 1.5 x 40mm, 10.9, PLT
18	4	EACH	BTC08035	BOLT, HEX, 8 x 1.25 x 35mm, 10.9, PLT
17	1	EACH	BMN80025	BKT, BACK, PL, SLIDE, IC, RE300
16	1	EACH	BMN80024	BKT, COMP, FRT, Z, IC, RE300
15	1	EACH	BMN80010	BKT, MAIN, SLIDE, ASSY, IC, RE300
14	1	EACH	BMN80009	BKT, MAIN, BASE PL, IC, RE300
13	2	EACH	BMN80008	VIBRATION ISOLATOR, BAR, 16.50 x 2 x 1.50
12	1	EACH	BMC83075	BKT, PL, EXHAUST, ADAPTER, D3RE, 10
11	1	EACH	BMC83074	BKT, RELAY, ISC, D3RE, 2010
10	1	EACH	BMC83070	BKT, SUP, WELDMT, ISC, D3RE, 10
9	1	EACH	BMC83059	BKT, DIAG, BRACE FRT, MFD, RE300
8	1	EACH	BMC83058	BKT, COVER, LIGHT PL, MFD, RE300
7	1	EACH	BMC83057	BKT, MAIN, FRT PL, MFD, RE300
6	1	EACH	BMC83054	BKT, MAIN, IDLER, WELDMT, RE300
5	1	EACH	BMC83053	BKT, DIAG, BRACE RR, MFD, RE300
4	1	EACH	BMC83052	BKT, MAIN, RR PL, MFD, RE300
3	2	EACH	BMC83051	BKT, SIDE, EXTENTION, PLATE
2	1	EACH	BMCS3047	BKT, BRACE, VERT, RR, BUMPER, ISC, D3
1	2	EACH	BEL22311	BELT, B Gr, 2311 mm (91") (BX88)

TRANSARCTIC INC.

DATE: 4/6/2010 BY: James Stewart

DESCRIPTION: MT KIT, ISC, D3RE OSG, 2B, 8" CRANK, '10

SCALE: 1:8

DWG NO: KMC84162

REV: 2

SHEET 1 OF 1

REV	DESCRIPTION	DATE	BY
2	ADDED P/N# BMC83074	3/16/2012	JRS
1	MODIFIED P/N# BMC83054	11/24/2010	JRS
0	RELEASED TO PRODUCTION	4/6/2010	JRS

UNSPECIFIED TOLERANCES: ALL DIM. ±.005

ONE DECIMAL PLACE (X.0) ±.010

TWO DECIMAL PLACE (X.00) ±.002

THREE DECIMAL PLACE (X.000) ±.0005

FRACTIONAL (X.1/8) ±.001

ANGULAR ±.05°

THIRD ANGLE PROJECTION

DRAWING UNIT OF MEASURE: MM (INCH)

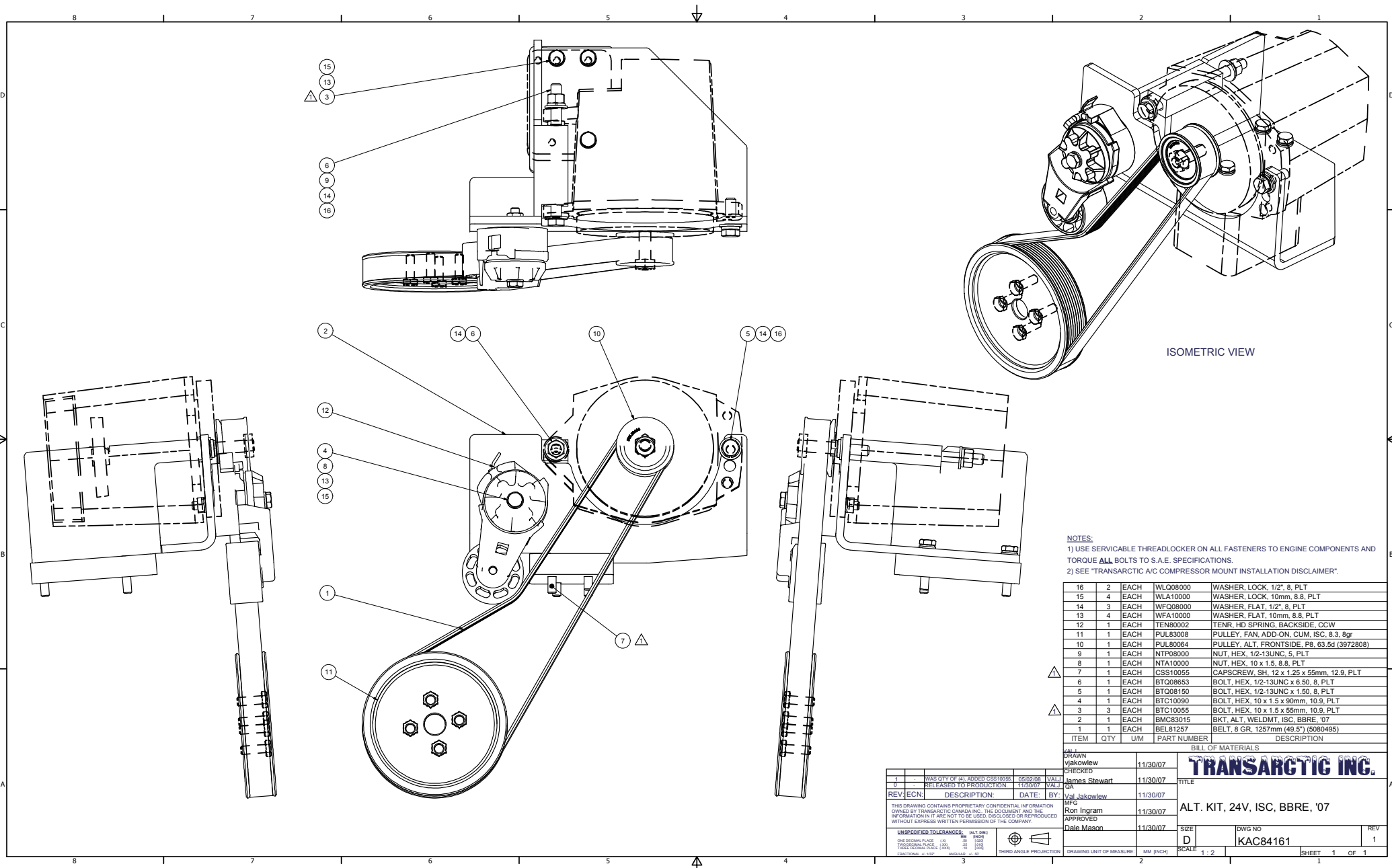

ISOMETRIC VIEW

NOTES:
 1) USE SERVICABLE THREADLOCKER ON ALL FASTENERS TO ENGINE COMPONENTS AND TORQUE ALL BOLTS TO S.A.E. SPECIFICATIONS.
 2) SEE "TRANSARGTIC A/C COMPRESSOR MOUNT INSTALLATION DISCLAIMER"

ITEM	QTY	UM	PART NUMBER	DESCRIPTION
16	2	EACH	WLG08000	WASHER, LOCK, 1/2", 8, PLT
15	4	EACH	WLA10000	WASHER, LOCK, 10mm, 8.8, PLT
14	3	EACH	WFG08000	WASHER, FLAT, 1/2", 8, PLT
13	4	EACH	WFA10000	WASHER, FLAT, 10mm, 8.8, PLT
12	1	EACH	TEN80002	TENR, HD SPRING, BACKSIDE, CCW
11	1	EACH	PUL83008	PULLEY, FAN, ADD-ON, CUM, ISC, 8.3, 8gr
10	1	EACH	PUL80064	PULLEY, ALT, FRONTSIDE, PB, 63.5d (3972808)
9	1	EACH	NTP08000	NUT, HEX, 1/2-13UNC, 5, PLT
8	1	EACH	NTA10000	NUT, HEX, 10 x 1.5, 8.8, PLT
7	1	EACH	CSS10055	CAPSCREW, SH, 12 x 1.25 x 55mm, 12.9, PLT
6	1	EACH	BT008653	BOLT, HEX, 1/2-13UNC x 6.50, 8, PLT
5	1	EACH	BT008150	BOLT, HEX, 1/2-13UNC x 1.50, 8, PLT
4	1	EACH	BT010090	BOLT, HEX, 10 x 1.5 x 90mm, 10.9, PLT
3	3	EACH	BT010055	BOLT, HEX, 10 x 1.5 x 55mm, 10.9, PLT
2	1	EACH	BMC83015	BKT, ALT, WELDMT, ISC, BBRE, '07
1	1	EACH	BEL81257	BELT, 8 GR, 1257mm (49.5") (5080495)

BILL OF MATERIALS					
DRAWN	HBAK0700	11/30/07	TRANSARGTIC INC.		
CHECKED	James Stewart	11/30/07			
REV	ECN	DESCRIPTION	DATE	BY	TITLE
			11/30/07	Val Jakowlew	ALT. KIT, 24V, ISC, BBRE, '07
			11/30/07	Ron Ingram	
			11/30/07	Dale Mason	
UNSPECIFIED TOLERANCES:		(ALL DIM)			
ONE DECIMAL PLACE (10)	AS SHOWN				
TWO DECIMAL PLACE (20)	AS SHOWN				
FRACTIONAL (1/32)	AS SHOWN				
DRAWING UNIT OF MEASURE		MM (INCH)	SCALE	1 : 2	SHEET 1 OF 1

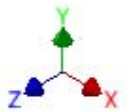
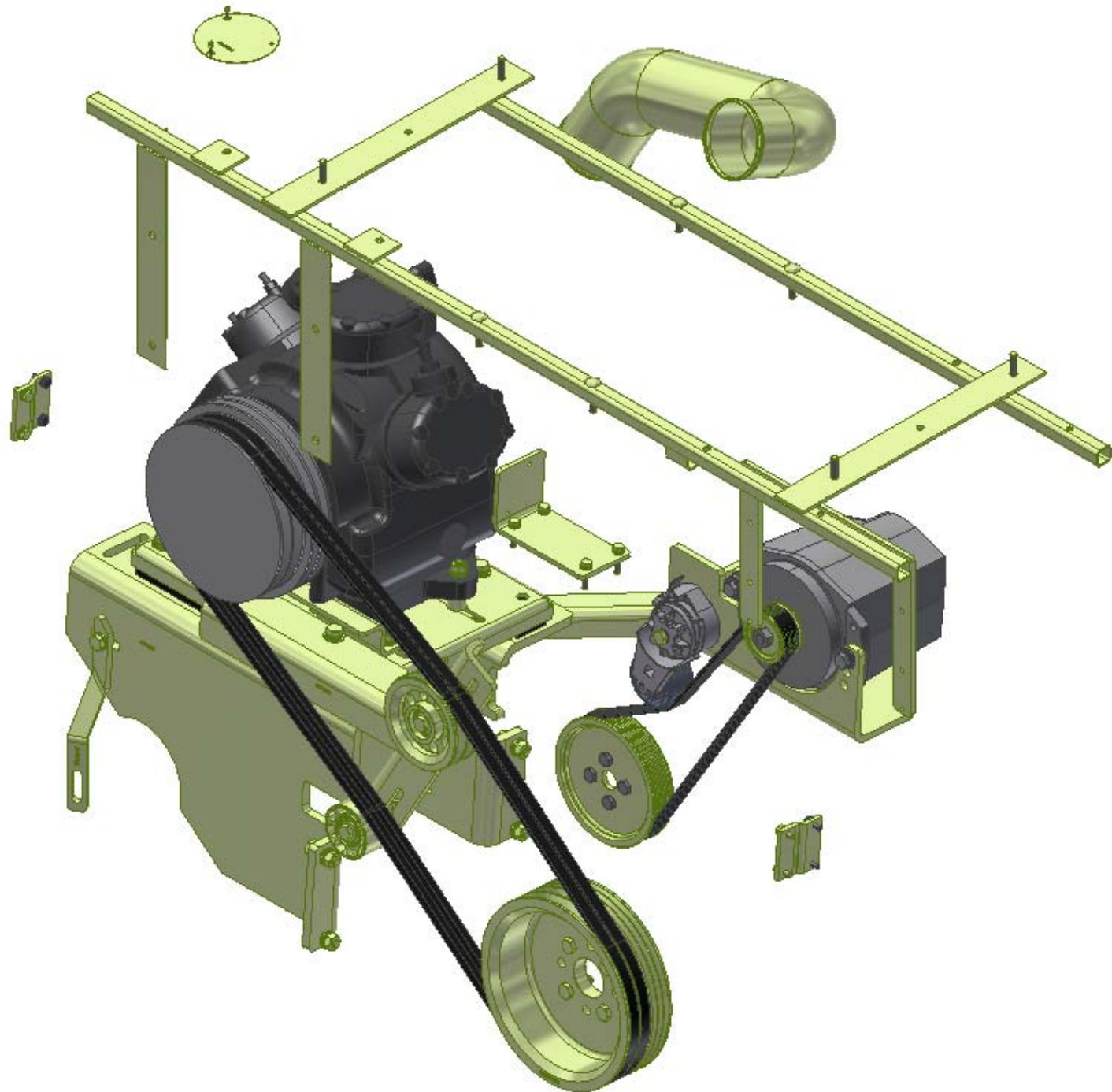

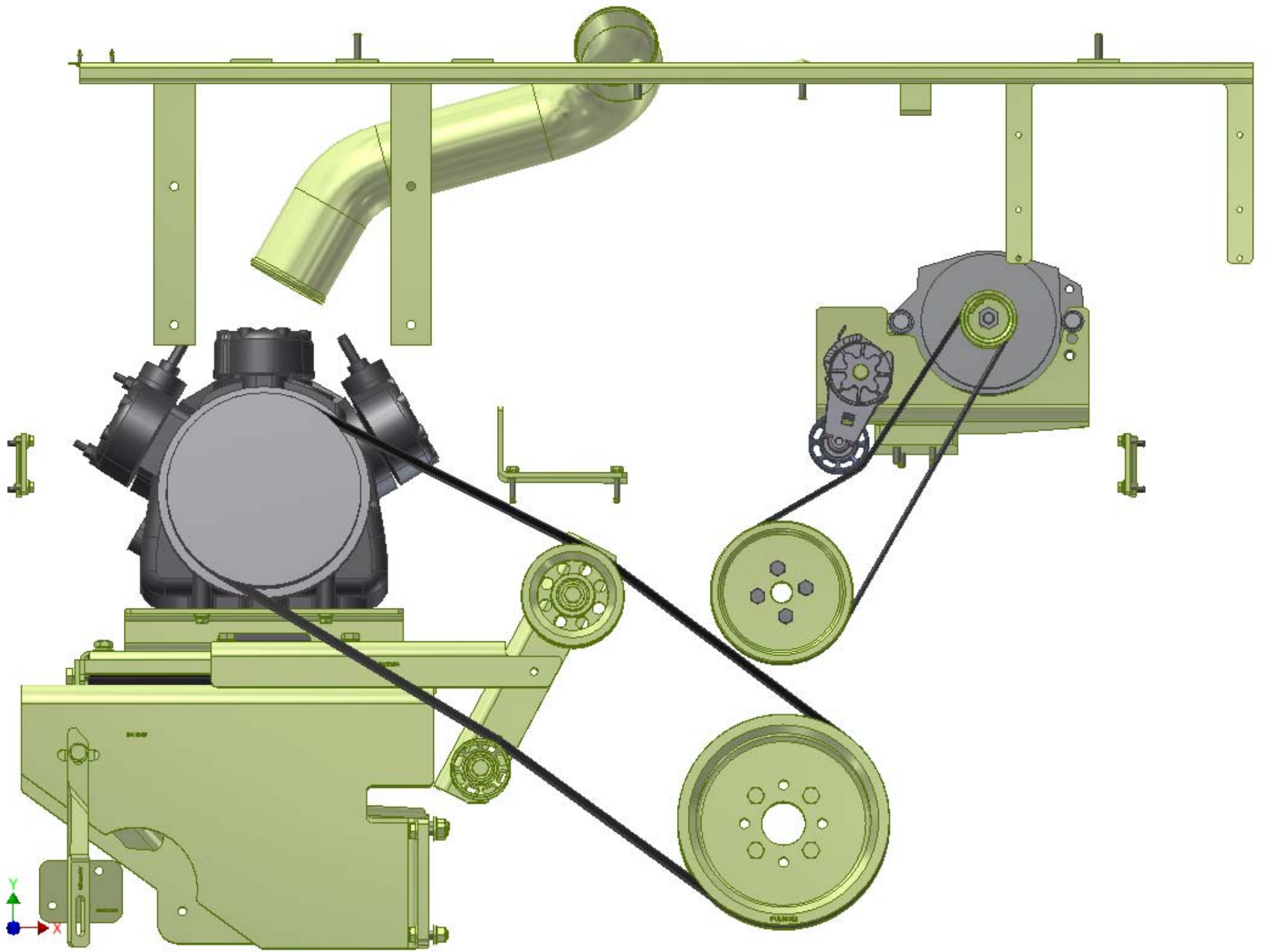



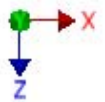
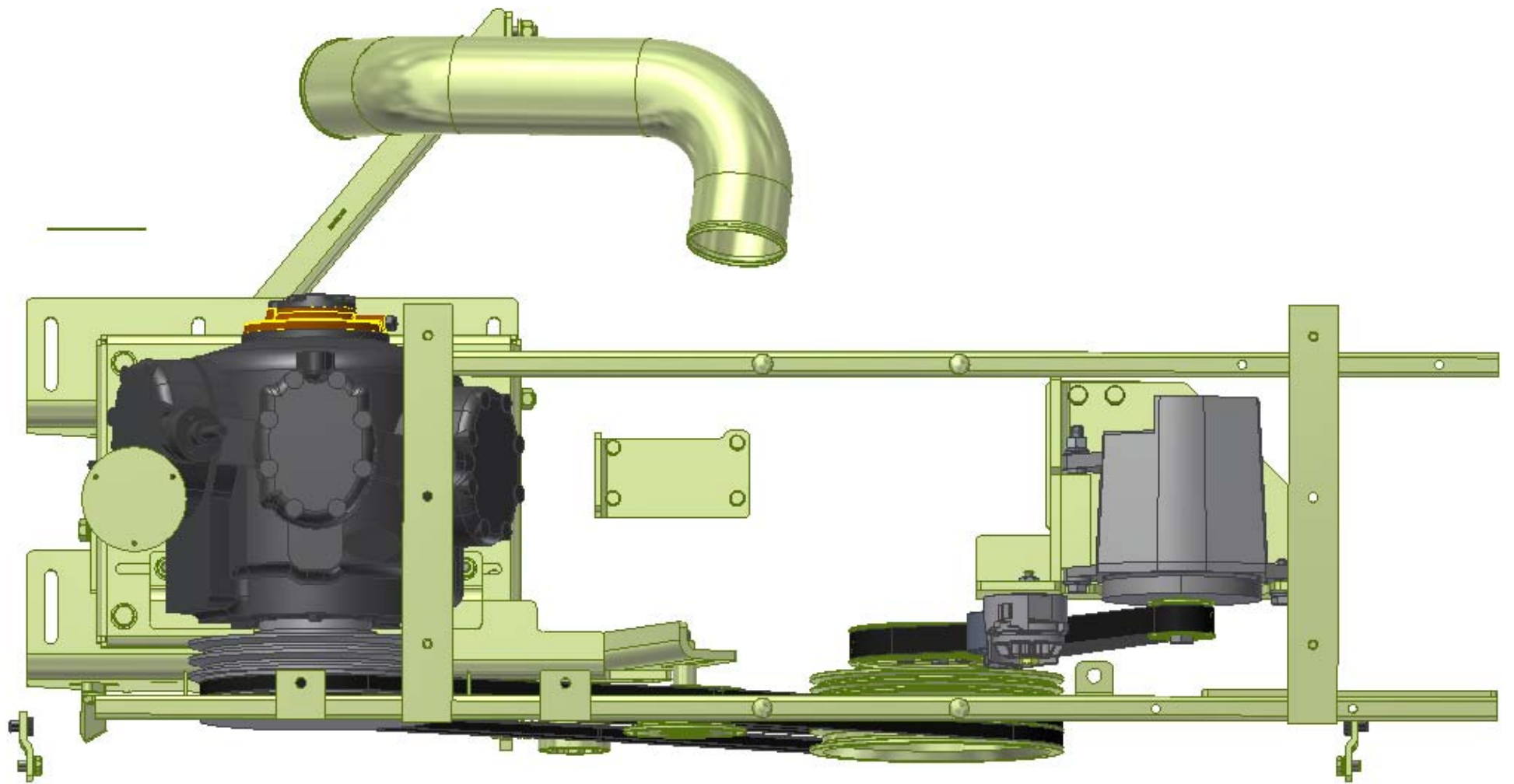

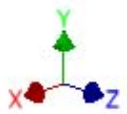

TransArctic A/C Compressor Mount Installation Disclaimer

All compressor mounts should be installed by qualified and trained personnel using proper tools and equipment in safe working conditions following industry standard guidelines for motor vehicle service and repair.

The installer of any compressor mount purchased from TransArctic must undertake all responsibility of issues arising from that compressor bracket being installed on any vehicle. As well as insure that a **proper and sufficient ground** is established between the compressors' clutches and the vehicle's engine. Mount functionality, operation and durability can all be compromised by an incompetent installation.

Due to the many different situations, parameters and application criteria, which are beyond the compressor mount manufacturer's control, TransArctic does not warrant design, durability, or operational functionality of any compressor mount improperly installed by another party.

With no implied guarantees it is the mount installer's strict responsibility to determine safety and functionality, of the compressor mount, at the time of installation.

Please contact TransArctic with any issue arising from installation so we may better improve the product. If you have any reservations about the compressor mount integrity contact TransArctic immediately at 1-877-COLD-AIR.

Mark OEM tensioner location

Install Kit

Check for Interferences

Check to ensure that the proper OEM tensioner orientation is maintained

Run engine with A/C system engaged for at least 10 minutes to run in belt

Check OEM tensioner orientation and adjust as required

Responsabilidad limitada de TransArctic en la instalación del soporte del compresor

Todos los soportes de los compresores deben ser instalados por personas calificadas y entrenadas, usando para ello los equipos y herramientas necesarios para esta labor en buenas condiciones y según las normas y guías para el servicio y/o reparación de motores de vehículos.

El instalador de los soportes comprados en TransArctic asume toda la responsabilidad de cualquier problema que surga en el soporte del compresor al vehículo; de igual manera es responsable que el cable a tierra sea conectado entre el embrague del compresor y el motor del vehículo.

Se advierte que el buen funcionamiento y la durabilidad del soporte pueden ser comprometidos por defectos en su instalación.

Debido a las diversas situaciones que se puedan presentar fuera del control del fabricante, TransArctic no garantiza el diseño, la durabilidad o el correcto funcionamiento de cualquier equipo inapropiadamente instalado por terceros.

Esta sobreentendido que el Instalador del montaje del compresor es estrictamente responsable de la seguridad y funcionamiento del equipo en el momento de la instalación.

Si tuviera algún problema o duda acerca de la instalación del soporte del compresor pongase en contacto inmediatamente con TransArctic al teléfono 1-877-COLD-AIR de modo que podamos mejorar nuestro producto.

Note la ubicación del medidor de tensión OEM

Instale el equipo

Controlar si hay interferencias.

Asegurese que el medidor de tensión mantenga la orientación justa.

Encienda el motor por lo menos 10 minutos con el sistema A/C enganchado para que la correa corra

Controle la orientación justa del medidor de tensión y ajuste a las condiciones requeridas del fabricante