

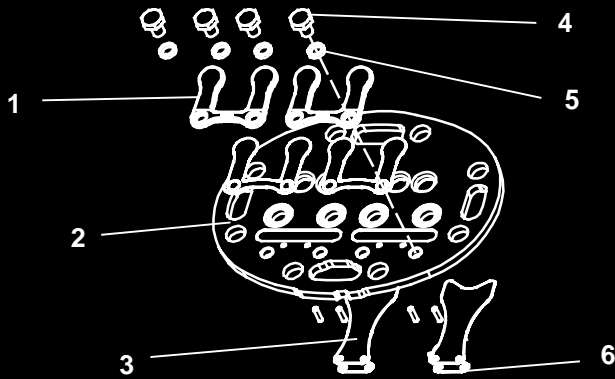

Compressor



SERVICE PARTS LIST  
for  
**MODEL 05G TWIN PORT  
COMPRESSOR**



**TRANSICOLD**

---

**SERVICE PARTS LIST**

**MODEL 05G TWIN PORT**

**COMPRESSOR**

# TABLE OF CONTENTS

INTRODUCTION .....	i
MODEL CHART .....	i
ORDERING INSTRUCTIONS .....	i
GENERAL NOTES .....	ii
COMPRESSOR OIL CHART .....	ii
1 CRANKCASE AND SUCTION SERVICE VALVE .....	1
2 COMPRESSOR BASE GROUP - ULTRA STYLE .....	2
3 COMPRESSOR BASE GROUP - STANDARD (NON-ULTRA) STYLE .....	3
4 BEARING HEAD AND OIL PUMP .....	4
5 CRANKSHAFT, ROD AND PISTON GROUP .....	5
6 SHAFT END GROUP .....	6
7 SHAFT SEAL RESERVOIR AND SHAFT END FLANGES .....	7
8 UNLOADERS .....	8
9 VALVE PLATE ASSEMBLY .....	10
10 UNLOADER VALVE PLATE ASSEMBLY .....	11
11 CYLINDER HEAD (SIDE) .....	12
12 CYLINDER HEAD (CENTER) .....	12
13 GASKET SET .....	13
14 CLUTCH ASSEMBLY - HOUSING MOUNTED (WARNER - GRAY IN COLOR) .....	14
15 CLUTCH ASSEMBLY - HOUSING MOUNTED (LINNIG - GOLD IN COLOR) .....	16
16 CLUTCH ASSEMBLY - SHAFT MOUNTED .....	18
17 UNLOADER KITS, BUS - PRESSURE TO ELECTRIC .....	20
PART NUMBER INDEX .....	Index-1

## INTRODUCTION

This parts list identifies service replacement parts for the 05G Twin Port Compressors listed in the Model Chart below. To find replacement parts, determine the major group in which the replacement parts are located (refer to the Table of Contents) and turn to the appropriate page for the illustrated parts breakdown of the replacement parts. A detailed list of the tools needed to service the 05G Twin Port Compressor may be found in the Service Tool List catalog 62-03213.

## MODEL CHART

<b>New Twin Port 05G Compressor Part Number</b>	<b>Carlyle/CSM Manufacturer's Number</b>	<b>Replaces This Part Number Of The Previous Design Three Port 05G Compressor</b>	<b>Compressor Configuration</b>	<b>Application</b>
18-00091-103	6GDG009UA0313A	18-00059-126RM	Ultra Bottom Cover, <b>37 CFM</b> , Contoured Pistons, Ultra Flange, 2 Electric Unloaders, No Oil	Trailer
18-00091-105	6GDJ009UA0313A	18-00059-72RM	Ultra Bottom Cover, <b>41 CFM</b> , Contoured Pistons, Ultra Flange, 2 Electric Unloaders, No Oil	Trailer
18-00091-106	6GCG008WB03131	18-00059-130RM	Standard Bottom Cover, <b>37 CFM</b> , Contoured Pistons, Star Flange, 1 Electric Unloader, No Oil	Truck (Supra 9XX)
18-00091-108	6GDG00DUA0313A	18-00059-128RM	Ultra Bottom Cover, <b>37 CFM</b> , Contoured Pistons, Ultra Flange With Threaded Clutch Hub, 2 Electric Unloaders, No Oil	Trailer With Standby
18-00091-150	6GCF00ATA03031	18-00059-169	Standard Bottom Cover, <b>37 CFM</b> , Flat Pistons, Half Moon Flange With Hub, 2 Electric Unloaders, No Oil	Bus (R-22 or R-134a)
18-00091-160	6GCH00ATA03431	17-44062-00	Standard Bottom Cover, <b>41 CFM</b> , Flat Pistons, Half Moon Flange With Hub, 2 Electric Unloaders, <b>5.8 Pints POE Oil</b>	Bus (R-134a)
18-00091-180	6GCF00A3A03031	18-00059-169	Standard Bottom Cover, <b>37 CFM</b> , Flat Pistons, Half Moon Flange With Hub, 2 Pressure Unloaders, No Oil	Bus (R-22 or R-134a)

## ORDERING INSTRUCTIONS

All orders and inquiries for parts must include: Unit Serial Number, Part Number, description of part as shown on list and quantity required. Address all correspondence for parts to the following address:

CARRIER TRANSICOLD DIVISION  
 Replacement Components Group, TR-20  
 P.O. Box 4805, Syracuse, NY 13221.  
 or  
 Fax to: (315) 432-3778

## GENERAL NOTES

To find replacement parts consult table of contents, and turn to the appropriate page for the illustrated breakdown of replacement parts. The following letter designations are used to classify parts throughout this list.

A/R *As Required*

NSA *Non-Stock Assembly* - order components listed under the assembly.

NSS *Not Sold Separately* - order next higher assembly or kit.

## COMPRESSOR OIL CHART

Part Number	Oil Type	Viscosity	Refrigerants	Application	Packaging
07-00275-00	Mineral	150	R-12, R-22, R-500, R-502	Large Bus	1 Gallon x 6
07-00377-00	Mineral	300	R-12, R-22, R-500	Large Bus	1 Gallon x 6
07-00430-00	Alkyl Benzene (A/B)	68	R-22	Large Bus	1 Gallon x 6
07-00274-00	Alkyl Benzene (A/B)	150	R-12, R-22, R-500, R-502	Trailer	1 Gallon x 6
07-00317-00PK6	Polyolester (POE)	68	R-134a, R-404a	Truck, Trailer, and Large Bus	1 Gallon x 6

## NOTE

Refer to the unit operation and service manual for the correct procedure for checking compressor oil level.

# 1 CRANKCASE AND SUCTION SERVICE VALVE

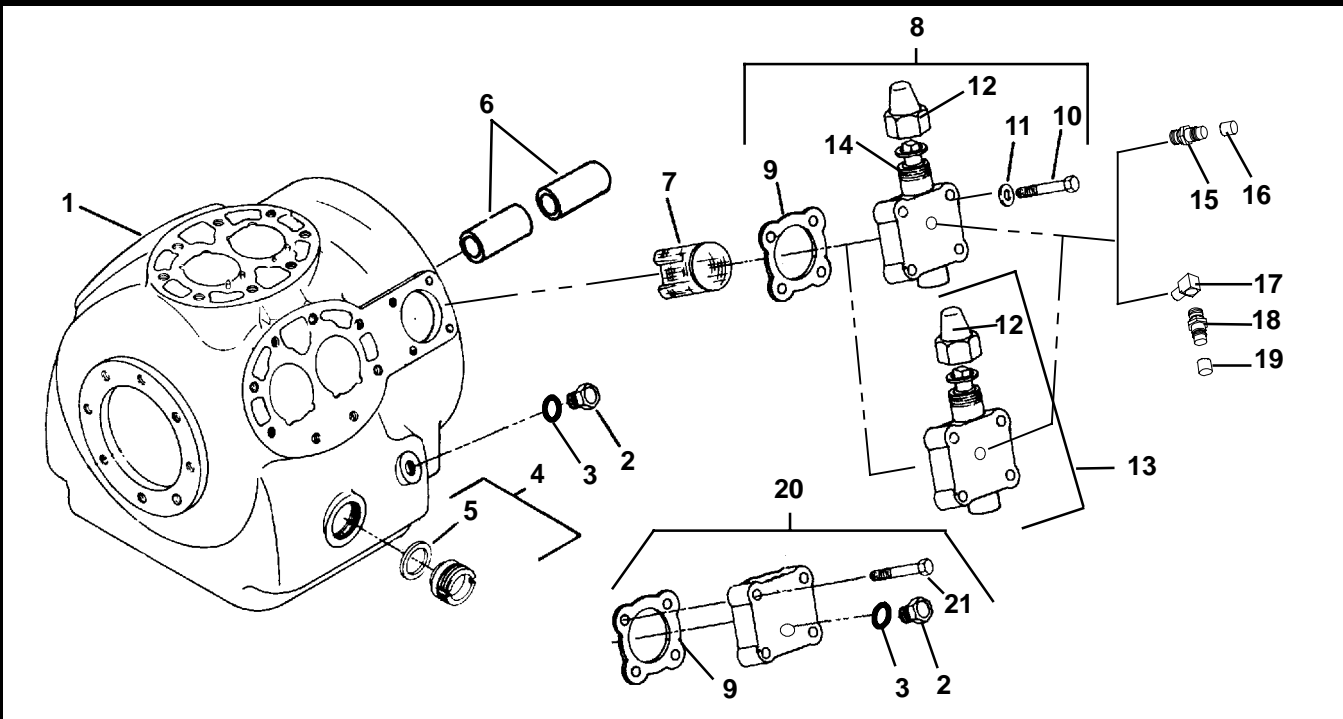

Item	Part Number	Description	Qty
1	NSA	Crankcase	1
2	17-44037-00	Plug, O-Ring, 7/16-20 - Includes:	1
3	42-00243-07	O-Ring	1
4	17-10218-00	Sight Glass, Oil Level - Includes:	2
5	17-10218-02	Gasket (Fiber)	1
	17-44021-00	Gasket (Metal)	
6	17-44015-00	Bearing, Main Seal End (Requires Line Boring)	2
7	17-44005-00	Strainer, Suction	1
8	17-31062-00	Valve, Service, 1-1/8 ODF (Bus/Supra 9xx) - Includes:	1
9	17-40005-05	Gasket, Service Valve (Fiber)	1
10	17-13020-00	Capscrew, 1/2-13 x 2-1/2 Inches Long - SAE Grade 5	4
11	17-40007-00	Gasket, Capscrew, 1/2 Inch	4
12	17-10812-01	Cap, Service Valve (Plastic) (With Relief Hole)	1
	17-10806-10	Cap, Service Valve (Brass)	
13	17-40002-01	Valve, Service, 1-3/8 ODF (Truck/Trailer) - Includes:	1
12	17-10812-01	Cap, Service Valve (Plastic) (With Relief Hole)	1
	17-10806-10	Cap, Service Valve (Brass)	
9	17-44141-00	Gasket, 4 Bolt Service Valve (Metal -May be used in place of fiber gasket)	1
14	34-50022-00	Packing Kit, Service Valve Stem (4-Bolt)	1
15	06DA403844	Valve, Access (1/4 Flare, Schrader) (for R-12, R-22, R-404A)	1
16	DD19CA061	Cap, 1/4 Flare, Schrader	1
17	40-00524-00	Elbow, 1/4 NPT x M13, Brass (for R-134a)	1
18	40-00520-00	Coupling, M13, R-134a, Brass - Includes:	1
19	40-00520-02	Cap, Service Port	1
20	17-13006-00	Kit, Valve Pad Blank Off, 4 Bolt Suction Service Valve - Includes:	1
2	17-44037-00	Plug, O-Ring, 7/16-20 - Includes:	1
3	42-00243-07	O-Ring	1
9	17-40005-05	Gasket, Service Valve (Fiber)	1
21	AA06BR293	Capscrew, 1/2-13 x 1-1/2 Inches Long - SAE Grade 5	4

## 2 COMPRESSOR BASE GROUP - ULTRA STYLE

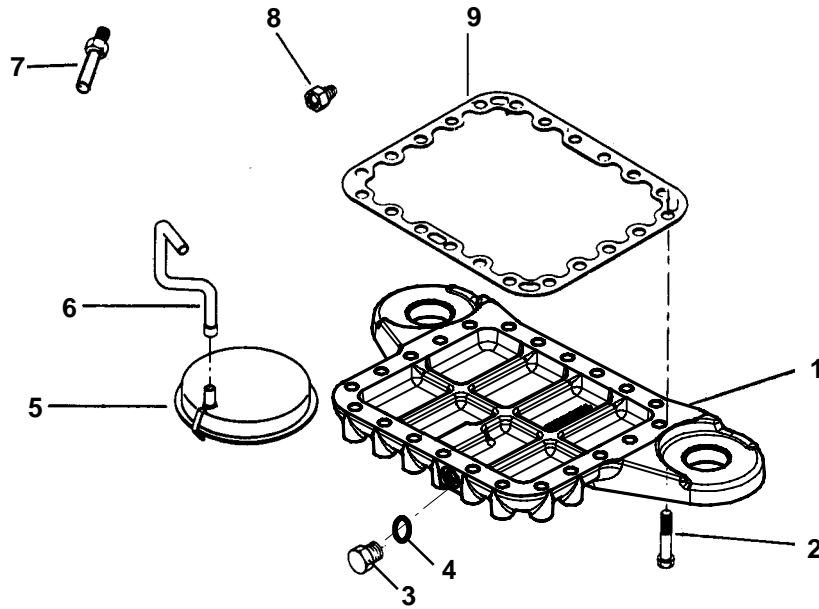

Item	Part Number	Description	Qty
1	17-44026-00	Plate, Bottom, Aluminum, (Ultra Style Compressors)	1
2	17-44117-00	Capscrew, Hex Head, 3/8-16 x 2-1/4 Inches Long - SAE Grade 8	22
3	17-44037-00	Plug, O-Ring, 7/16-20 - Includes:	1
4	42-00243-07	O-Ring	1
5	17-40020-00	Oil Filter Screen Assembly	1
6	17-40021-00	Tube, Oil Suction	1
7	17-44011-00	Oil Relief Valve	1
8	17-40042-00	Oil Return Check Valve Assembly	2
9	17-44129-00	Gasket, Bottom Plate (Metal)	1

### 3 COMPRESSOR BASE GROUP - STANDARD (NON-ULTRA) STYLE

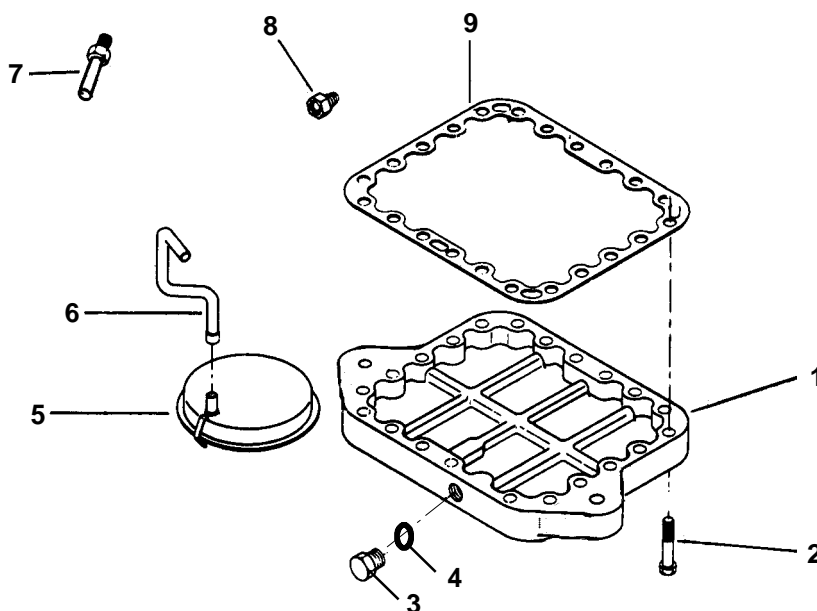

Item	Part Number	Description	Qty
1	17-44035-00	Plate, Bottom, Aluminum, (Non-Ultra Style Compressors)	1
2	17-44117-00	Capscrew, Hex Head, 3/8-16 x 2-1/4 Inches Long - SAE Grade 8	22
3	17-44037-00	Plug, O-Ring, 7/16-20 - Includes:	1
4	42-00243-07	O-Ring	1
5	17-40020-00	Oil Filter Screen Assembly	1
6	17-40021-00	Tube, Oil Suction	1
7	17-44011-00	Oil Relief Valve	1
8	17-40042-00	Oil Return Check Valve Assembly	2
9	17-44129-00	Gasket, Bottom Plate (Metal)	1



#### 4 BEARING HEAD AND OIL PUMP

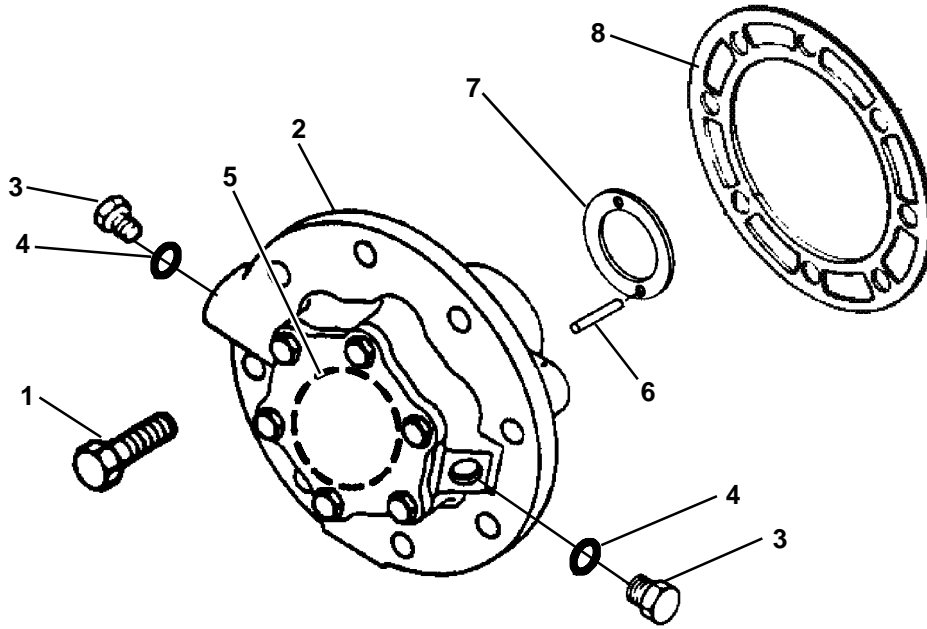

Item	Part Number	Description	Qty
1	17-10308-00	Capscrew, Hex Head, 3/8-16 x 1-1/4 Inches Long - SAE Grade 5	8
2	17-44137-00	Oil Pump and Bearing Head - Includes:	1
3	17-44037-00	Plug, O-Ring, 7/16-20 - Includes:	2
4	42-00243-07	O-Ring	2
5	17-44139-00	O-Ring, Pump Cover Plate	1
6	17-40204-00	Pin, Roll, 1/8 x 1/2 Inch	2
7	17-55009-01	Thrustwasher, Pump End	1
8	17-40078-05	Gasket, Bearing Head (Fiber)	1
	17-44022-00	Gasket, Bearing Head (Metal)	

## 5 CRANKSHAFT, ROD AND PISTON GROUP

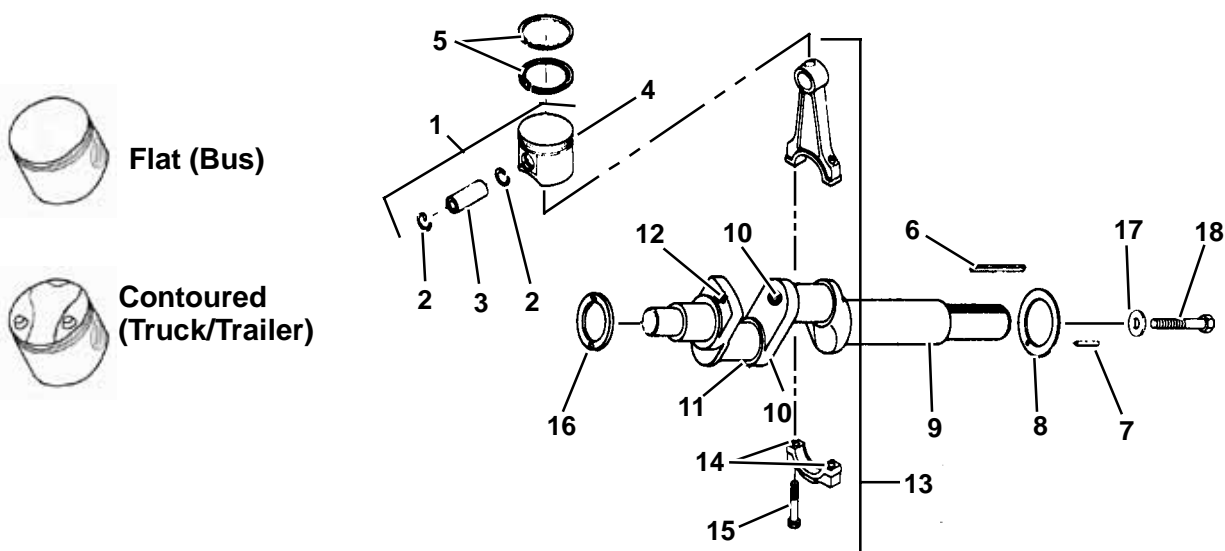

Item	Part Number	Description	Qty
1	17-44045-01	Piston, 05G37 CFM, <b>Flat</b> , Standard - Includes:	6
	17-44045-03	Piston, 05G37 CFM, <b>Flat</b> , .020 Inch Oversize - Includes:	
	17-44121-01	Piston, 05G41 CFM, <b>Flat</b> , Standard - Includes:	
	17-44122-01	Piston, 05G41 CFM, <b>Flat</b> , .020 Inch Oversize - Includes:	
1	17-44070-00	Piston, 05G37 CFM, <b>Contoured</b> , Standard - Includes:	6
	17-44071-00	Piston, 05G37 CFM, <b>Contoured</b> , .020 Inch Oversize - Includes:	
	17-44072-00	Piston, 05G41 CFM, <b>Contoured</b> , Standard - Includes:	
	17-44073-00	Piston, 05G41 CFM, <b>Contoured</b> , .020 Inch Oversize - Includes:	
2	17-40053-00	Retainer, Piston Pin	2
3	<b>NSS</b>	Pin, Piston	1
4	<b>NSS</b>	Piston	1
5	17-40055-00	Ring, Compression (Standard)	12
	17-55025-00	Ring, Compression (.020 Inch Oversize)	12
6	17-40324-00	Key, Crankshaft, 1/4 x 1/4 x 1-1/2 Inches Long (For Shaft Mounted or No Clutch)	1
	68G2-9072	Key, Crankshaft (For Housing Mounted Clutch)	
7	17-44036-00	Pin, Spiral, 1/8 x 1/2 Inch Long	2
8	17-44008-00	Thrustwasher, Seal End	1
9	17-44074-00	Crankshaft Assembly, 05G37 CFM (05G Twin Port) - Includes:	1
	17-44075-00	Crankshaft Assembly, 05G41 CFM (05G Twin Port) - Includes:	
10	17-40317-00	Expansion Plug	2
11	AF55CQ164	Setscrew, 1/4-28 x 1/2 Inch Long	1
12	34-00300-07	Capscrew, Hex Head, 1/4-20 x 7/8 Inch Long - Grade 5	1
13	17-40056-02	Connecting Rod and Cap Assembly (Standard) - Includes:	6
	17-55023-00	Connecting Rod and Cap Assembly (.010 Inch Undersize) - Includes:	A/R
14	17-40057-00	Pin, Dowel	2
15	17-55008-00	Capscrew (Special)	2
16	17-55009-01	Thrustwasher, Pump End	1
17	34-00616-00	Washer, 13/32 ID x 1-1/2 OD x 3/16 Thick	1
18	34-00613-07	Capscrew, Hex Head, 3/8-24 UNF x 7/8 Inch Long - SAE Grade 8	1

**6 SHAFT END GROUP**

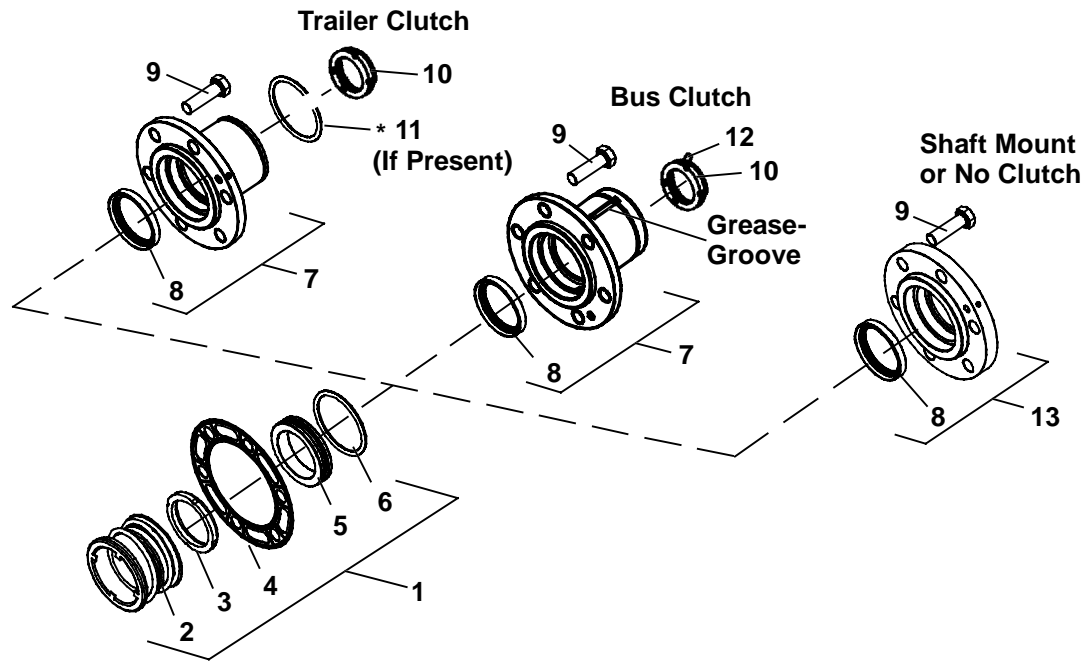

\*NOTE: Early production trailer compressors may have had the snap ring style clutch hub. Should the hub require replacement, it must be converted to the threaded clutch hub (Item 7).

Item	Part Number	Description	Qty
1	17-44770-00	Seal Assembly (Shaft) - Includes:	1
2	<b>NSS</b>	Spring And Bellows Assembly, Shaft Seal	1
3	17-44768-00	Rotor, Seal	1
4	17-44004-06	Gasket, Seal Cover - (Metal)	1
5	<b>NSS</b>	Stator, Seal, (Wear Ring)	1
6	17-44773-00	O-Ring, Stator	1
7	17-44766-00	Hub Assembly, Housing Mounted Clutch, Threaded, No Groove - <b>Trailer</b> - Includes:	1
	17-44767-00	Hub Assembly, Housing Mounted Clutch, Threaded, W/Grease Groove - <b>Bus</b> - Includes:	
8	17-44765-00	Seal, Lip, Shaft Seal	1
4	17-44004-06	Gasket, Seal Cover - (Metal)	1
9	17-40308-00	Capscrew, 3/8-16 X 1-1/4 Inch Long Grade 5	6
10	34-01304-00	Nut, Hub, Without Grease Fitting Port ( <b>Trailer Only</b> )	1
	34-06083-00	Nut, Hub, Without Grease Fitting Port - <b>Bus</b>	
	34-01161-00	Nut, Hub, With Grease Fitting Port - ( <b>Fitting Not Included</b> ) <b>Bus</b>	
11	50-00221-30	Ring, Snap (If Applicable)	1
12	40-01132-00	Fitting, Grease, 1/4-28 NPT- <b>Bus</b>	1
13	17-44772-00	Seal Cover Assembly, Shaft (Gland Plate) - Includes:	1
4	17-44004-06	Gasket, Seal Cover - (Metal)	1
8	17-44765-00	Seal, Lip, Shaft Seal	1

## 7 SHAFT SEAL RESERVOIR AND SHAFT END FLANGES

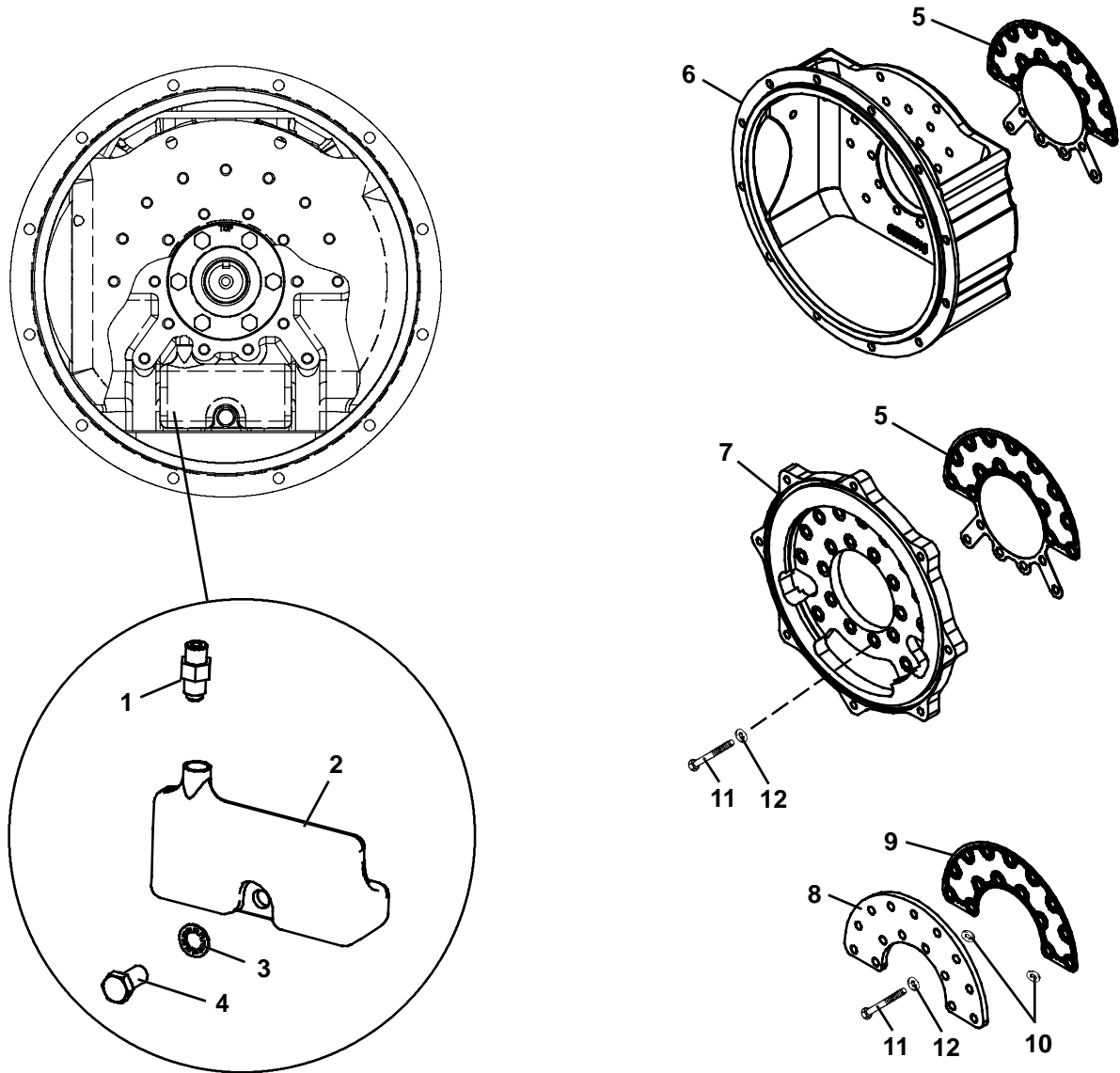

Item	Part Number	Description	Qty
1	05GA503-724	Access Valve, <b>Coreless</b> , 7/16-20, With O-Ring	1
2	17-44771-00	Reservoir, Shaft Seal (Bus Application)	1
	17-44774-00	Reservoir, Shaft Seal (Truck/Trailer Application)	
3	05GA503-734	Washer, Internal Tooth, 3/8 Inch, Plated	1
4	AA06GS228	Cap Screw, Hex Head, 3/8-16 X 0.75 Inch Long, Grade 8	1
5	17-44119-00	Gasket, End Flange, Ultra Style or Full Ring Flange (Used With Items 6 and 7)	1
6	17-44025-00	End Flange, Ultra Style (Trailer)	1
7	17-44002-00	End Flange, Full Ring (Star Flange)	1
8	17-44127-00	End Flange, Half Moon (Bus)	1
9	17-44118-00	Gasket, Half Moon End Flange (Used Only With Item 8)	1
10	17-44014-00	Gasket, Flange Spacer (Used Only With Items 8 and 9)	2
11	17-10308-00	Cap Screw, Hex Head, 3/8-16 X 1.25 Inch Long, Grade 5	A/R
12	17-40019-00	Gasket, Cap Screw	A/R

**Pressure Valve**

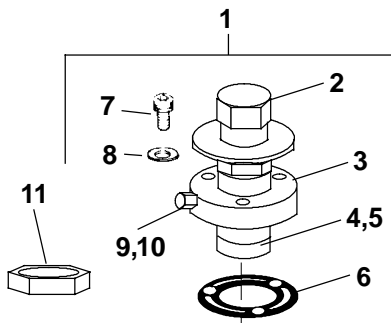

**Electric Valve**

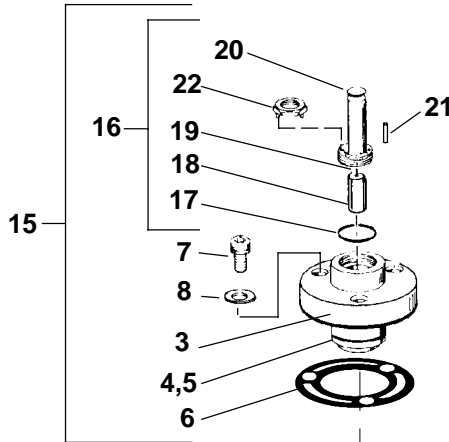

**Valve Plug**

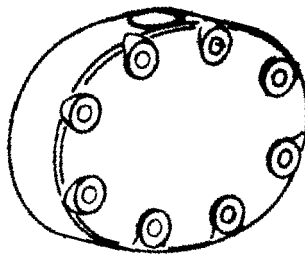
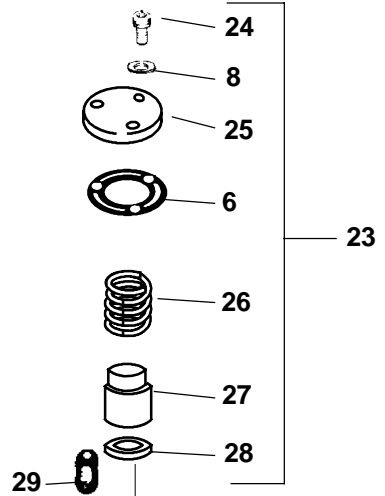

**COILS**

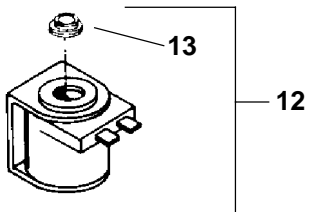

OR

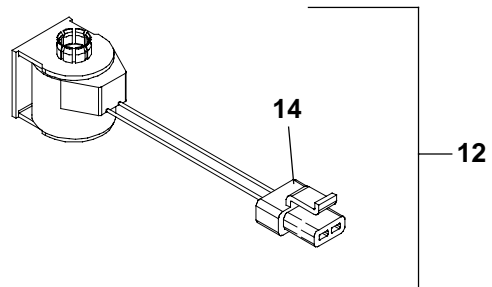

**8 UNLOADERS (Continued)**

Item	Part Number	Description	Qty
1	17-55018-01	Valve Assembly (Pressure) - Includes:	A/R
2	<b>NSS</b>	Power Assembly, Unloader (Suction Pressure Activated)	1
3	<b>NSS</b>	Body Assembly, Valve	1
4	17-40409-00	Piston, Unloader - Includes:	1
5	17-55010-00	Ring, Piston	1
6	17-40104-07	Gasket, Unloader Valve	1
7	17-40111-00	Screw, Socket Head, 1/4-28 x 3/4 Inch Long	1
8	17-40104-20	Gasket, Socket Head Screw, 1/4 Inch	1
9	17-55028-00	Cap, Adjustment Screw	1
10	42-50019-00	O-Ring, Adjustment Screw Cap	1
11	34-01139-00	Nut, Unloader Adjuster Lock	1
12	22-02804-00	Coil, Valve, 12 VDC With Connector ( <b>Truck/Trailer</b> ) - Includes:	A/R
	22-02567-00	Coil, Valve, 12 VDC With Spade Terminal - Includes:	
	14-00143-07	Coil, Valve, 12 VDC With 6 inch wire leads - Includes:	
	22-50030-00	Coil, Valve, 24 VDC With 42 inch wire leads - Includes:	
	22-02567-01	Coil, Valve, 24 VAC With Spade Terminal - Includes:	
	16-00149-00	Coil, Valve, 115 VAC With 42 inch Wire Leads - Includes:	
	17-10829-00	Coil, Valve, 230 VAC With 42 inch Wire Leads - Includes:	
13	17-40408-02	Cap, Snap	1
14	22-50078-02SV	Connector, 2 Wire, 22-02804-00 Coil Only (Mates With 22-50078-01SV)	1
15	17-40417-00	Valve Assembly (Electric) - Includes:	A/R
3	<b>NSS</b>	Body Assembly, Valve	1
4	17-40409-00	Piston, Unloader - Includes:	1
5	17-55010-00	Ring, Piston	1
6	17-40104-07	Gasket, Unloader Valve	1
7	17-40111-00	Screw, Socket Head, 1/4-28 x 3/4 Inch Long	1
8	17-40104-20	Gasket, Socket Head Screw, 1/4 Inch	1
16	17-40418-00	Kit, Valve Stem Repair (For 17-40417-00) - Includes:	A/R
17	42-00243-03	Gasket, O-ring	1
18	<b>NSS</b>	Plunger Assembly	1
19	<b>NSS</b>	Spring, Plunger	1
20	<b>NSS</b>	Enclosing Tube	1
21	34-06026-00	Pin, Unloader Coil Retainer	1
22	<b>NSS</b>	Tool, Valve Stem Installation/Removal	1
23	17-55013-00	Kit, Plug, To Fully Load Cylinder Bank - Includes:	A/R
24	17-10721-00	Screw, Socket Head, 1/4-28 x 1.0 Inch Long	3
25	<b>NSS</b>	Plate Cover	1
26	<b>NSS</b>	Spring	1
27	<b>NSS</b>	Plug	1
28	17-55014-00	Ring, Seat	1
29	17-40108-00	Strainer	1
6	17-40104-07	Gasket, Unloader Valve	1
8	17-40104-20	Gasket, Socket Head Screw, 1/4 Inch	1

## 9 VALVE PLATE ASSEMBLY

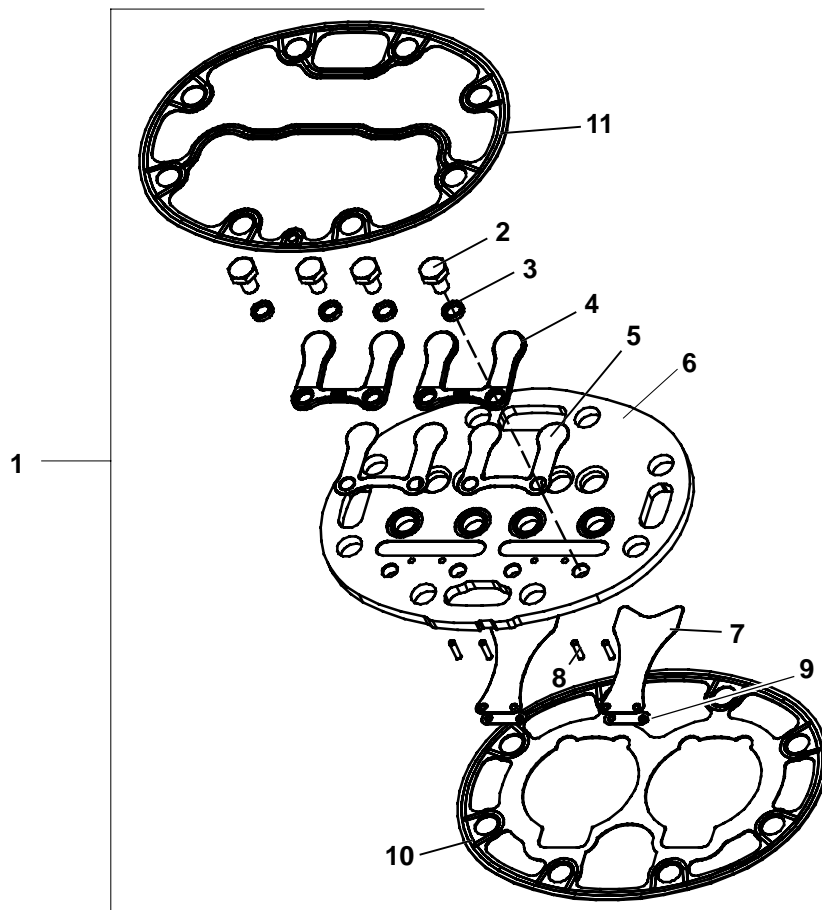

CAUTION: The above valve plate can only be used on the Twin Port 05G compressor.  
**It will not function in** the previous design (3 port) 05G compressor.

Item	Part Number	Description	Qty
1	17-44742-00	Valve Plate Assembly, <b>Center or Side Bank With No Unloader</b> - Includes:	1
2	17-44113-00	Capscrew, HexHead, 1/4-28 x 3/8 Inch Long	4
3	17-10715-00	Lockwasher, 1/4 Inch	4
4	17-44750-00	Backer, Discharge Valve	2
5	17-44749-00	Valve, Discharge	2
6	<b>NSS</b>	Valve Plate	1
7	17-44748-00	Valve, Suction	2
8	17-40057-00	Dowel, Pin Suction Valve	4
9	17-44751-00	Spring, Suction Valve	2
10	17-44746-00	Gasket, Valve Plate, Center or Side Banks	1
11	17-44747-00	Gasket, Cylinder Head, Center or Side Banks	1

## 10 UNLOADER VALVE PLATE ASSEMBLY

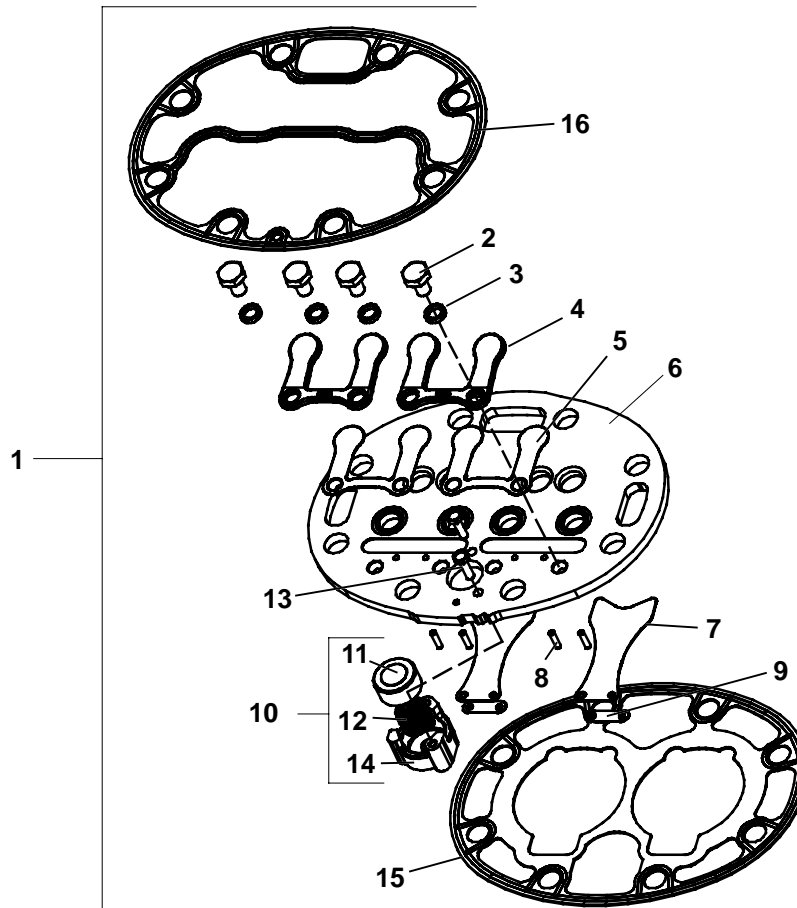

CAUTION: The above valve plate can only be used on the Twin Port 05G compressor.  
**It will not function in** the previous design (3 port) 05G compressor.

Item	Part Number	Description	Qty
1	17-44744-00	Valve Plate Assembly, <b>Side Bank With Unloader</b> - Includes:	1
2	17-44113-00	Capscrew, HexHead, 1/4-28 x 3/8 Inch Long	4
3	17-10715-00	Lockwasher, 1/4 Inch	4
4	17-44750-00	Backer, Discharge Valve	2
5	17-44749-00	Valve, Discharge	2
6	<b>NSS</b>	Valve Plate	1
7	17-44748-00	Valve, Suction	2
8	17-40057-00	Dowel, Pin Suction Valve	4
9	17-44751-00	Spring, Suction Valve	2
10	17-55012-00	Check Valve, Unloader, - Includes:	1
11	17-40104-08	Piston, Check Valve	1
12	17-40104-09	Spring, Check Valve	1
13	<b>NSS</b>	Screw, Round Phillips Head, #6-32 x 1/2 Inch Long	2
14	<b>NSS</b>	Body Check Valve	1
15	17-44746-00	Gasket, Valve Plate, Center or Side Banks	1
16	17-44747-00	Gasket, Cylinder Head, Center or Side Banks	1



## 11 CYLINDER HEAD (SIDE)

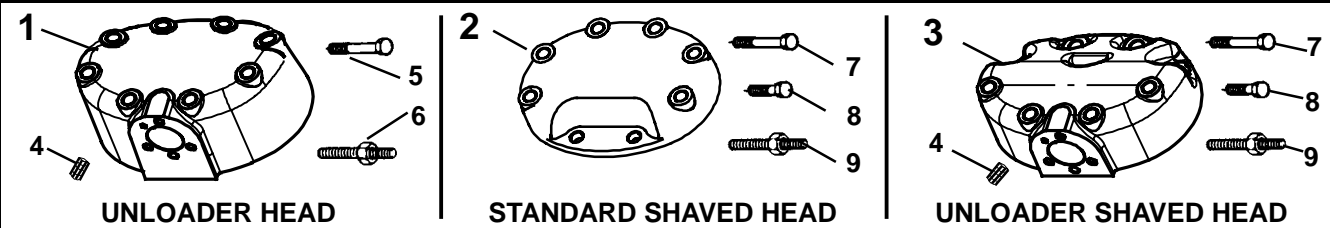

Item	Part Number	Description	Qty
1	17-44743-00	Cylinder Head, Unloader - Side Banks	A/R
2	17-44753-00	Cylinder Head - Side Banks, Shaved (Standard, No Unloader)	A/R
3	17-44790-00	Cylinder Head, Unloader - Side Banks - Shaved	A/R
4	17-40108-00	Strainer	1
5	17-10224-05	Capscrew, Hex Head, 3/8 -16 x 3-1/4 Inches Long - SAE Grade 8	8
6	17-44017-03	Stud, Cylinder Head (Unloader or Center), 3/8 -16 x 4-1/4 Inches Long	A/R
7	17-44117-00	Capscrew, Hex Head, 3/8 -16 x 2-1/4 Inches Long - SAE Grade 8	6
8	AA06GR232	Capscrew, Hex Head, 3/8 -16 x 1-1/4 Inches Long - SAE Grade 8	2
9	17-44780-00	Stud, Cylinder Head (Shaved), 3/8 -16 x 3-1/4 Inches Long	A/R

## 12 CYLINDER HEAD (CENTER)

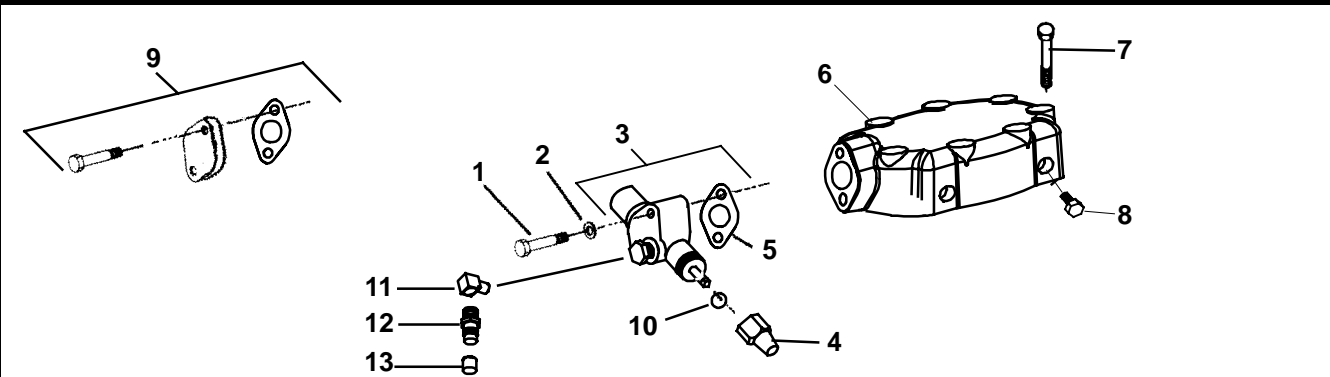

Item	Part Number	Description	Qty
1	34-00302-16	Capscrew, Hex Head, 5/16 -18 x 2 Inches Long - SAE Grade 5	2
2	17-40013-00	Gasket, Capscrew, 5/16 Inch	2
3	14-01042-07	Valve, Service 7/8 Inch ODF (1/8 Inch FPT Gauge Port)- Includes:	1
	14-00206-01	Valve, Service 7/8 Inch ODF (M15 Gauge Port For R-134a) - Includes:	1
4	17-10812-01	Cap, Service Valve (Plastic) (With Relief Hole)	1
5	17-10811-05	Gasket, Service Valve (Fiber)	1
	17-44138-00	Gasket, Service Valve (Metal)	1
4	17-10806-10	Cap, Service Valve (Brass)	1
6	17-44752-00	Cylinder Head, Center Bank, One Pressure Port (Bus)	1
	17-44754-00	Cylinder Head, Center Bank, Two Pressure Ports (T/T)	1
7	17-10224-05	Capscrew, Hex Head, 3/8 -16 x 3 -1/4 Inches Long - SAE Grade 8	8
8	CA63AA051	Pipe Plug, 1/4 -18NPT (package of 20)	A/R
9	17-13004-00	Kit, Valve Pad Blank Off, 2 Bolt Service Valve	1
10	17-13022-00	Graphite Packing, Service Valve Stem (2-Bolt)	1
11	40-00524-01	Elbow, 1/8 MPT x M15 - Brass (for R -134a)	1
12	40-00520-01	Coupling, M15, High Side - Brass - Includes:	1
13	40-00520-03	Cap, Service Port	1
11	40-00060-08	Elbow, 1/8 MPT x 1/4 FPT - Brass (for R -12, R -22)	1
12	06DA403-844	Valve, Access (1/4 Flare, Schrader)	1
13	DD19CA061	Cap, 1/4 Flare, Schrader	1

**13 GASKET SET**

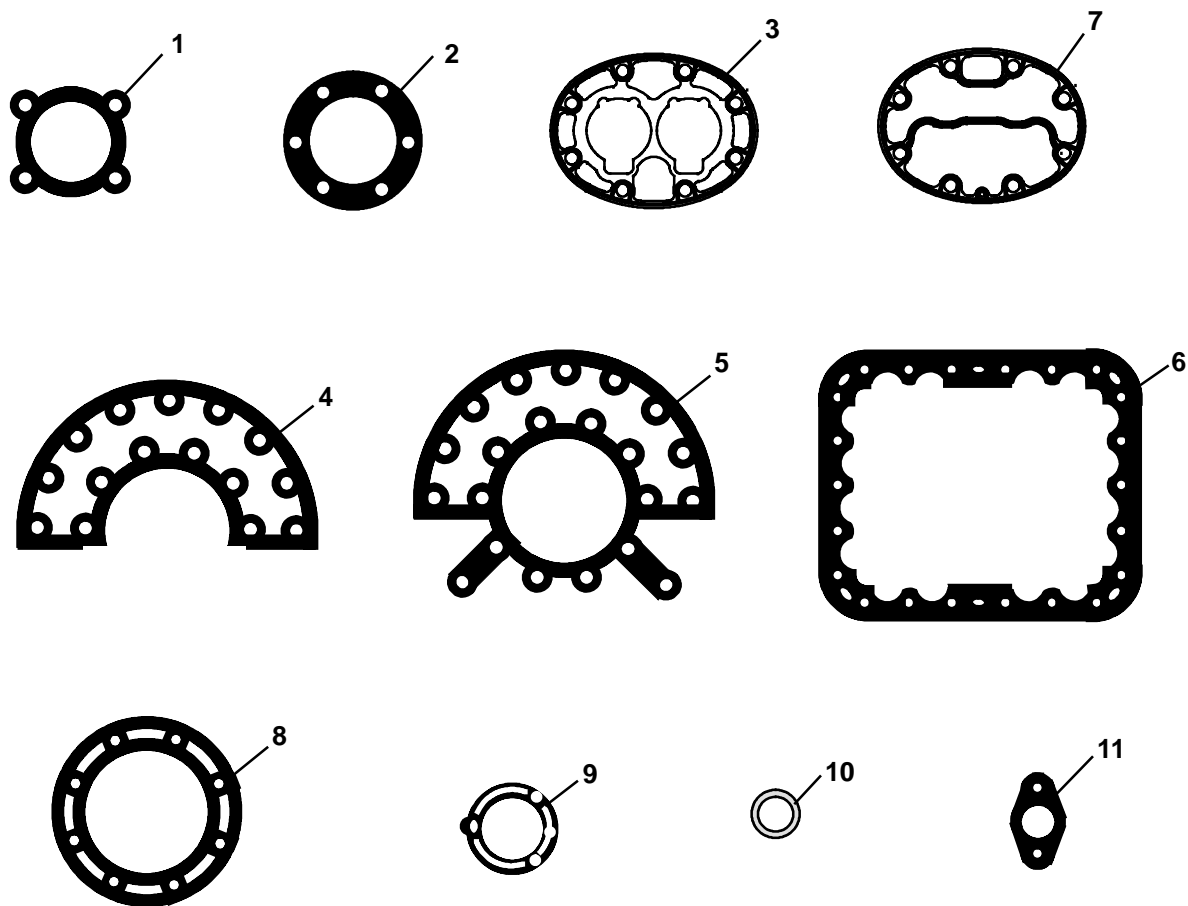

Item	Part Number	Description	Qty
-	17-44775-00	Gasket Set, Metal - Includes:	1
1	17-44141-00	Gasket, Suction Service Valve - 4 Bolt	1
2	17-44004-06	Gasket, Shaft Seal	1
3	17-44746-00	Gasket, Valve Plate	3
4	17-44118-00	Gasket, End Flange	1
5	17-44119-00	Gasket, End Flange	1
6	17-44129-00	Gasket, Bottom Plate	1
7	17-44747-00	Gasket, Cylinder Head, Center or Side Banks	3
8	17-44022-00	Gasket, Pump End Bearing Head	1
9	17-40104-07	Gasket, Unloader Body	2
10	17-44021-00	Gasket, Sight Glass	2
11	17-44138-00	Gasket, Service Valve - 2 Bolt	2

**14 CLUTCH ASSEMBLY - HOUSING MOUNTED (WARNER - GRAY IN COLOR)**

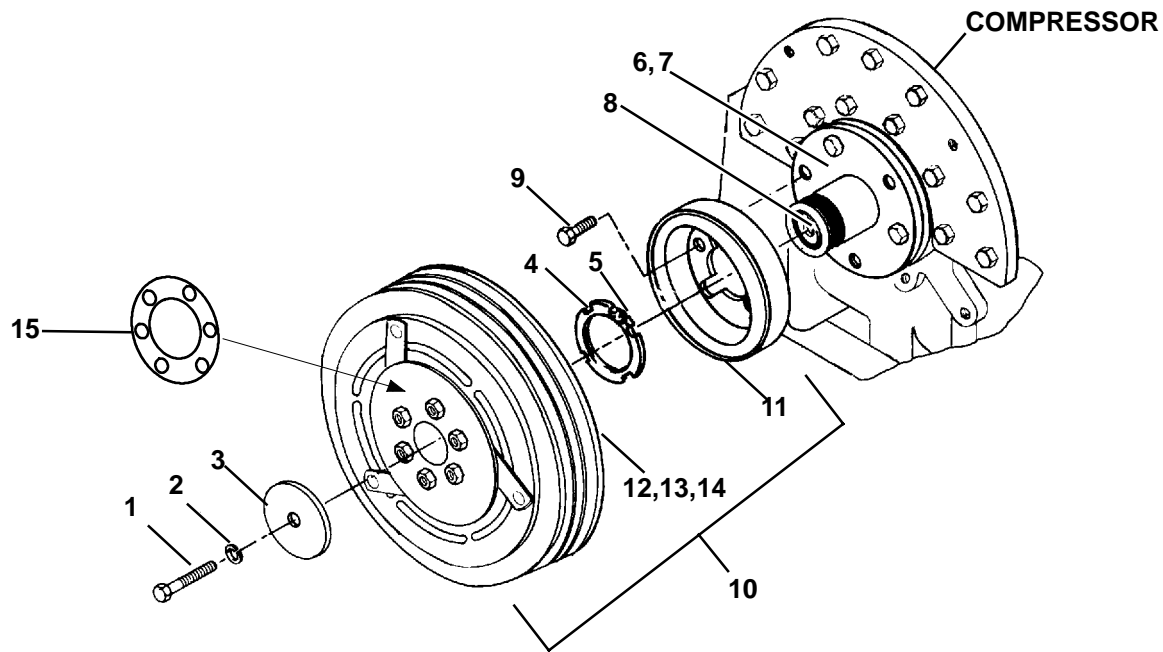

Item	Part Number	Description	Qty
NS	76-50013-00	Kit, Conversion Shaft to Housing Mounted Clutch	A/R
1	34-00613-07	Capscrew, Hex Head, 3/8-24 x 7/8 Inch Long - SAE Grade 8	1
2	AU11AR241	Washer, Lock, Spring, 3/8 Inch	1
3	34-00616-00	Washer, 13/32 ID x 1-1/2 OD x 3/16 Inch Thick	1
4	34-01161-00	Nut, Hub, With Grease Fitting Port (Fitting Not Included)	1
	34-06083-00	Nut, Hub Without Grease Fitting Port	
5	40-01132-00	Fitting, Grease, 1/4-18	1
6	17-44041-01	Hub, Clutch Mounting - Includes:	1
7	17-44042-00	Ring, Felt and Retainer	1
8	68G2-9072	Key, Crankshaft, Special	1
9	17-10308-00	Capscrew, Hex Head, 3/8-16 x 1-1/4 Inches Long - SAE Grade 8	1
10	50-01122-01	Clutch, Assembly, 24 VDC, 2-C Grooves, 9 Inch Diameter - Includes:	1
11	50-01122-50	Coil, 24 VDC	1
12	50-01122-85	Rotor/Armature, 2-C Grooves, 9 Inch Diameter - Includes:	1
13	34-01186-00	Ring, Snap	1
14	04-00130-00	Bearing, Rotor	1
10	50-01122-04	Clutch, Assembly, 12 VDC, 2-C Grooves, 9 Inch Diameter - Includes:	1
11	50-01122-41	Coil, 12 VDC	1
12	50-01122-85	Rotor/Armature, 2-C Grooves, 9 Inch Diameter - Includes:	1
13	34-01186-00	Ring, Snap	1
14	04-00130-00	Bearing, Rotor	1
10	50-01122-02	Clutch, Assembly, 24 VDC, 3-3V Grooves, 8.48 Inch Diameter - Includes:	1
11	50-01122-50	Coil, 24 VDC	1
12	50-01122-86	Rotor/Armature, 3-3V Grooves, 8.48 Inch Diameter - Includes:	1
13	34-01186-00	Ring, Snap	1
14	04-00130-00	Bearing, Rotor	1

**14 CLUTCH ASSEMBLY - HOUSING MOUNTED (WARNER - GRAY IN COLOR) - Continued**

<b>Item</b>	<b>Part Number</b>	<b>Description</b>	<b>Qty</b>
10	50-01122-07	Clutch, Assembly, 24 VDC, 2-B Grooves, 9 Inch Diameter - Includes:	1
11	50-01122-50	Coil, 24 VDC	1
12	50-01122-90	Rotor/Armature, 2-B Grooves, 9 Inch Diameter - Includes:	1
13	34-01186-00	Ring, Snap	1
14	04-00130-00	Bearing, Rotor	1
10	50-01122-09	Clutch, Assembly, 24 VDC, 4 Grooves (2-A/2-B), 10.35 Inch Diameter - Includes:	1
11	50-01122-50	Coil, 24 VDC	1
12	50-01122-501	Rotor/Armature, 4 Grooves (2-A/2-B), 10.35 Inch Diameter - Includes:	1
13	34-01186-00	Ring, Snap	1
14	04-00130-00	Bearing, Rotor	1
10	50-01122-12	Clutch, Assembly, 24 VDC, 2-5V Grooves, 8.7 Inch Diameter - Includes:	1
11	50-01122-50	Coil, 24 VDC	1
12	50-01122-91	Rotor/Armature, 2-5V Grooves, 8.7 Inch Diameter - Includes:	1
13	34-01186-00	Ring, Snap	1
14	04-00130-00	Bearing, Rotor	1
10	50-01122-14	Clutch, Assembly, 24 VDC, 2-5V Grooves, 10.5 Inch Diameter - Includes:	1
11	50-01122-50	Coil, 24 VDC	1
12	50-01122-93	Rotor/Armature, 2-5V Grooves, 10.5 Inch Diameter - Includes:	1
13	34-01186-00	Ring, Snap	1
14	04-00130-00	Bearing, Rotor	1
15	50-01122-65	Shim, .010 Inch Thick	5
	50-01122-66	Shim, .020 Inch Thick	1

## 15 CLUTCH ASSEMBLY - HOUSING MOUNTED (LINNIG - GOLD IN COLOR)

Note: Multiple groove rotor/armature designation describes groove location(s) starting at the compressor side and working out. Example: 3 Grooves 2B/1A shown below.

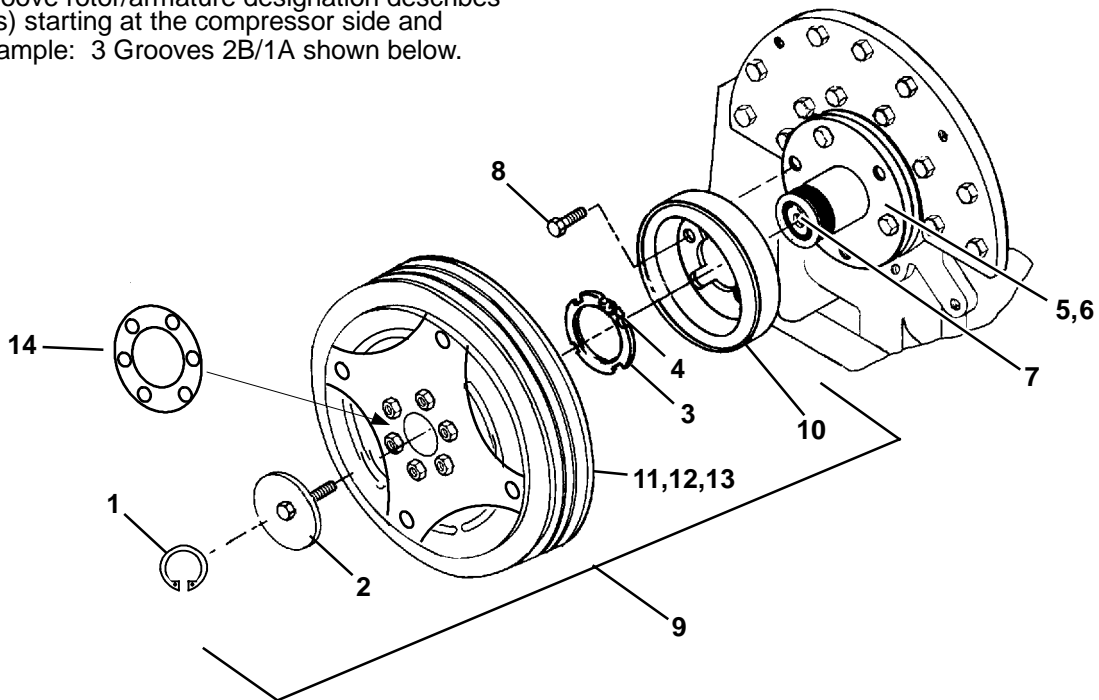

Item	Part Number	Description	Qty
NS	76-50013-00	Kit, Conversion Shaft to Housing Mounted Clutch	A/R
1	34-50035-00	Ring, Snap	1
2	34-50034-00	Bolt, Retaining, Special	1
3	34-01161-00	Nut, Hub, With Grease Fitting Port (Fitting Not Included)	1
	34-06083-00	Nut, Hub Without Grease Fitting Port	
4	40-01132-00	Fitting, Grease, 1/4-18	1
5	17-44041-01	Hub, Clutch Mounting - Includes:	1
6	17-44042-00	Ring, Felt and Retainer	1
7	68G2-9072	Key, Crankshaft, Special	1
8	17-10308-00	Capscrew, Hex Head, 3/8-16 x 1-1/4 Inches Long - SAE Grade 8	1
9	50-00226-09	Clutch Assembly, 24 VDC, 4 Grooves (2A/2B), 10.35 Inch Dia. - Includes:	1
10	50-00226-50	Coil, 24 VDC	1
11	50-00226-501	Rotor/Armature, 4 Grooves (2A/2B), 10.35 Inch Diameter - Includes:	1
12	50-50040-05	Ring, Snap	1
13	50-50040-04	Bearing	1
9	50-00226-18	Clutch Assembly, 12 VDC, 4 Grooves (2B/2A), 10.35 Inch Dia. - Includes:	1
10	50-00226-41	Coil, 12 VDC	1
11	50-50040-11	Rotor/Armature, 4 Grooves (2B/2A), 10.35 Inch Diameter - Includes:	1
12	50-50040-05	Ring, Snap	1
13	50-50040-04	Bearing	1

<b>15 CLUTCH ASSEMBLY - HOUSING MOUNTED (LINNIG - GOLD IN COLOR) - continued</b>			
<b>Item</b>	<b>Part Number</b>	<b>Description</b>	<b>Qty</b>
9	50-00226-19	Clutch Assembly, 24 VDC, 4 Grooves (2B/2A), 10.35 Inch Dia. - Includes:	1
10	50-00226-50	Coil, 24 VDC	1
11	50-50040-11	Rotor/Armature, 4 Grooves (2B/2A), 10.35 Inch Diameter - Includes:	1
12	50-50040-05	Ring, Snap	1
13	50-50040-04	Bearing	1
9	50-01130-03	Clutch Assembly, 24 VDC, 3-3V Grooves, 8.48 Inch Diameter - Includes:	1
10	50-00226-50	Coil, 24 VDC	1
11	50-50040-02	Rotor/Armature, 3-3V Grooves, 8.48 Inch Diameter - Includes:	1
12	50-50040-05	Ring, Snap	1
13	50-50040-04	Bearing	1
9	50-01130-20	Clutch Assembly, 12 VDC, 2-B Grooves, 10.35 Inch Diameter - Includes:	1
10	50-00226-41	Coil, 12 VDC	1
11	50-50040-03	Rotor/Armature, 2-B Grooves, 10.35 Inch Diameter - Includes:	1
12	50-50040-05	Ring, Snap	1
13	50-50040-04	Bearing	1
9	50-01130-21	Clutch Assembly, 24 VDC, 2-B Grooves, 10.35 Inch Diameter - Includes:	1
10	50-00226-50	Coil, 24 VDC	1
11	50-50040-03	Rotor/Armature, 2-B Grooves, 10.35 Inch Diameter - Includes:	1
12	50-50040-05	Ring, Snap	1
13	50-50040-04	Bearing	1
9	50-01130-22	Clutch Assembly, 12 VDC, 2-C Grooves, 10 Inch Diameter - Includes:	1
10	50-00226-41	Coil, 12 VDC	1
11	50-50040-12	Rotor/Armature, 2-C Grooves, 10 Inch Diameter - Includes:	1
12	50-50040-05	Ring, Snap	1
13	50-50040-04	Bearing	1
14	50-00226-65	Shim, .012 Inch Thick	5
	50-00226-66	Shim, .039 Inch Thick	1

**16 CLUTCH ASSEMBLY - SHAFT MOUNTED**

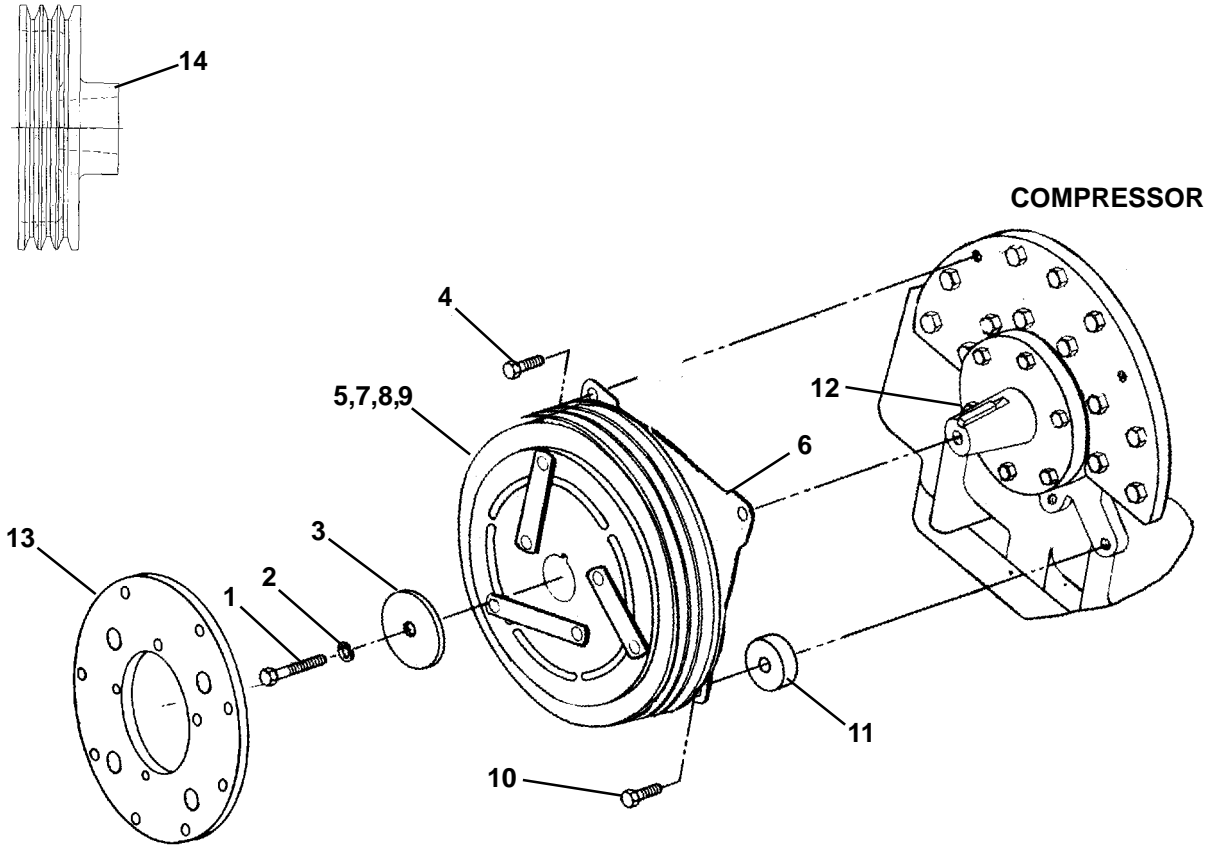

Item	Part Number	Description	Qty
1	34-00613-07	Capscrew, Hex Head, 3/8 UNF x 7/8 Inch Long - SAE Grade 8	1
2	AU11AR241	Washer, Lock, Spring, 3/8 Inch	1
3	34-00616-00	Washer, 13/32 ID x 1-1/2 OD x 3/16 Inch Thick	1
4	17-40037-05	Capscrew, Hex Head, 3/8-16 x 1 Inch Long	2

**16 CLUTCH ASSEMBLY - SHAFT MOUNTED**

<b>Item</b>	<b>Part Number</b>	<b>Description</b>	<b>Qty</b>
5	50-01108-00	Clutch, 24 VDC, 2-C Grooves, 9 Inch Diameter	1
	50-01110-00	Clutch, 24 VDC, 3-3V Grooves, 8.48 Inch Diameter	
	50-01110-01	Clutch, 12 VDC, 3-3V Grooves, 8.48 Inch Diameter	
	50-01114-00	Clutch, 12 VDC, 2-B Grooves, 8.64 Inch Diameter	
6	50-50011-00	Coil, 24 VDC	1
	50-50014-00	Coil, 12 VDC	
7	50-50015-00	Ring, Retaining - External	1
8	50-50016-00	Ring, Retaining - Internal	1
9	50-50017-00	Bearing	1
10	17-10308-00	Capscrew, Hex Head, 3/8-16 x 1-1/4 Inches Long - SAE Grade 8	2
11	68G2-8522-1	Spacer, 1-3/8 OD x 1/2 Inch Thick - CRES	2
12	17-40324-00	Key, Crankshaft, 1/4 x 1/4 x 1-1/2 Inches Long	1
13	50-01115-00	Plate, Adapter (Used with 50-01114 Clutch)	1
14	68G2-1823	Sheave, Power Takeoff, 3-3V Grooves, 6 Inch Diameter, (On Allison Transmission)	1



**17 UNLOADER KITS, BUS - PRESSURE TO ELECTRIC**



**17 UNLOADER KIT - PRESSURE TO ELECTRIC - R-134a ONLY - 24 VDC**

Item	Part Number	Description	Qty
	74-50111-00	Kit, Convert Pressure Hot Gas Bypass to Electric Unloader (24 VDC), Includes:	2
1	17-40417-00	Unloader Valve	2
2	68PD-2-102-3	Solenoid Coil - 24 VDC	2
3	12-00334-02	Switch, Pressure (UPS2) - R-134a	1
4	12-00334-03	Switch, Pressure (UPS1) - R-134a	1
5	40-00249-01	Fitting, Tee, Male Branch, 1/4 FPT x 1/4 FPT x 1/4 MPT	1
6	40-00243-01	Fitting, Tee, Street, 1/4 MPT x 1/4 x 1/4 FPT	1
7	06DA403-844	Valve, Access (1/4 Flare, Schrader)	3
8	40-00528-02	Connector, 1/4 FPT x 7/16-20 Straight Thread With O-Ring - Includes:	1
9	42-00243-07	O-Ring	1
10	DD19CA061	Cap, 1/4 Flare, Schrader	1
11	22-50222-00	Wire Harness	1

<b>17 UNLOADER KIT - PRESSURE TO ELECTRIC - R-22 ONLY - 24 VDC</b>			
<b>Item</b>	<b>Part Number</b>	<b>Description</b>	<b>Qty</b>
	74-50111-01	Kit, Convert Pressure Hot Gas Bypass to Electric Unloader (24 VDC), Includes:	2
1	17-40417-00	Unloader Valve	2
2	68PD-2-102-3	Solenoid Coil - 24 VDC	2
3	12-00334-00	Switch, Pressure (UPS2) - R-22	1
4	12-00334-01	Switch, Pressure (UPS1) - R-22	1
5	40-00249-01	Fitting, Tee, Male Branch, 1/4 FPT x 1/4 FPT x 1/4 MPT	1
6	40-00243-01	Fitting, Tee, Street, 1/4 MPT x 1/4 x 1/4 FPT	1
7	06DA403-844	Valve, Access (1/4 Flare, Schrader)	3
8	40-00528-02	Connector, 1/4 FPT x 7/16-20 Straight Thread With O-Ring - Includes:	1
9	42-00243-07	O-Ring	1
10	DD19CA061	Cap, 1/4 Flare, Schrader	1
11	22-50222-00	Wire Harness	1
<b>17 UNLOADER KIT - PRESSURE TO ELECTRIC - R-134a ONLY - 36 VDC</b>			
	74-50111-02	Kit, Convert Pressure Hot Gas Bypass to Electric Unloader (36 VDC), Includes:	2
1	17-40417-00	Unloader Valve	2
2	14-50086-00	Solenoid Coil - 36 VDC	2
3	12-00334-02	Switch, Pressure (UPS2) - R-134a	1
4	12-00334-03	Switch, Pressure (UPS1) - R-134a	1
5	40-00249-01	Fitting, Tee, Male Branch, 1/4 FPT x 1/4 FPT x 1/4 MPT	1
6	40-00243-01	Fitting, Tee, Street, 1/4 MPT x 1/4 x 1/4 FPT	1
7	06DA403-844	Valve, Access (1/4 Flare, Schrader)	3
8	40-00528-02	Connector, 1/4 FPT x 7/16-20 Straight Thread With O-Ring - Includes:	1
9	42-00243-07	O-Ring	1
10	DD19CA061	Cap, 1/4 Flare, Schrader	1
11	22-50222-00	Wire Harness	1
<b>17 UNLOADER KIT - PRESSURE TO ELECTRIC - R-22 ONLY - 36 VDC</b>			
	74-50111-03	Kit, Convert Pressure Hot Gas Bypass to Electric Unloader (36 VDC), Includes:	2
1	17-40417-02	Unloader Valve	2
2	14-50086-00	Solenoid Coil - 36 VDC	2
3	12-00334-00	Switch, Pressure (UPS2) - R-22	1
4	12-00334-01	Switch, Pressure (UPS1) - R-22	1
5	40-00249-01	Fitting, Tee, Male Branch, 1/4 FPT x 1/4 FPT x 1/4 MPT	1
6	40-00243-01	Fitting, Tee, Street, 1/4 MPT x 1/4 x 1/4 FPT	1
7	06DA403-844	Valve, Access (1/4 Flare, Schrader)	3
8	40-00528-02	Connector, 1/4 FPT x 7/16-20 Straight Thread With O-Ring - Includes:	1
9	42-00243-07	O-Ring	1
10	DD19CA061	Cap, 1/4 Flare, Schrader	1
11	22-50222-00	Wire Harness	1

# PART NUMBER INDEX

PART NO.	PAGE NO.	PART NO.	PAGE NO.	PART NO.	PAGE NO.
04-00130-00	14, 15	17-40056-02	5	17-44073-00	5
05GA503-724	7	17-40057-00	5, 10, 11	17-44074-00	5
05GA503-734	7	17-40078-05	4	17-44075-00	5
06DA403-844	1, 12, 20, 21	17-40104-07	9, 13	17-44113-00	10, 11
12-00334-00	21	17-40104-08	11	17-44117-00	2, 3, 12
12-00334-01	21	17-40104-09	11	17-44118-00	7, 13
12-00334-02	20, 21	17-40104-20	9	17-44119-00	7, 13
12-00334-03	20, 21	17-40108-00	9, 12	17-44121-00	13
14-00143-07	9	17-40111-00	9	17-44121-01	5
14-00206-01	12	17-40204-00	4	17-44122-01	5
14-01042-07	12	17-40317-00	5	17-44127-00	7
14-50086-00	21	17-40324-00	5, 19	17-44129-00	2, 3, 13
16-00149-00	9	17-40408-02	9	17-44137-00	4
17-10218-00	1	17-40409-00	9	17-44138-00	12, 13
17-10218-02	1	17-40417-00	9, 20, 21	17-44139-00	4
17-10224-05	12	17-40417-02	21	17-44141-00	1, 13
17-10308-00	4, 14, 16, 19	17-40418-00	9	17-44742-00	10
17-10715-00	10, 11	17-44002-00	7	17-44743-00	12
17-10721-00	9	17-44004-06	6, 13	17-44744-00	11
17-10806-10	1, 12	17-44005-00	1	17-44746-00	10, 11, 13
17-10811-05	12	17-44008-00	5	17-44747-00	10, 11, 13
17-10812-01	1, 12	17-44011-00	2, 3	17-44748-00	10, 11
17-10829-00	9	17-44013-00	12	17-44749-00	10, 11
17-13004-00	12	17-44014-00	7	17-44750-00	10, 11
17-13006-00	1	17-44015-00	1	17-44751-00	10, 11
17-13020-00	1	17-44017-03	12	17-44752-00	12
17-13022-00	1, 12	17-44022-00	4, 13	17-44753-00	12
17-31062-00	1	17-44025-00	7	17-44754-00	12
17-40002-01	1	17-44026-00	2	17-44765-00	6
17-40005-05	1	17-44035-00	3	17-44766-00	6
17-40007-00	1	17-44036-00	5	17-44767-00	6
17-40019-00	7	17-44037-00	1, 2, 3, 4	17-44768-00	6
17-40020-00	2, 3	17-44041-01	14, 16	17-44770-00	6
17-40021-00	2, 3	17-44042-00	14, 16	17-44771-00	7
17-40037-05	18	17-44045-01	5	17-44772-00	6
17-40042-00	2, 3	17-44045-03	5	17-44773-00	6
17-40053-00	5	17-44062-00	14, 18	17-44774-00	7
17-40055-00	5	17-44070-00	5	17-44775-00	13
		17-44071-00	5	17-44780-00	12
		17-44072-00	5	17-44790-00	12
				17-55008-00	5

# PART NUMBER INDEX

PART NO.	PAGE NO.	PART NO.	PAGE NO.	PART NO.	PAGE NO.
17-55009-01	4, 5	42-00243-07	1, 2, 3, 4, 20, 21	50-50040-02	17
17-55010-00	9	42-50019-00	9	50-50040-03	17
17-55012-00	11	50-00221-30	6	50-50040-04	16, 17
17-55013-00	9	50-00226-09	16	50-50040-05	16, 17
17-55014-00	9	50-00226-18	16	50-50040-11	16, 17
17-55018-01	9	50-00226-19	17	50-50040-12	17
17-55023-00	5	50-00226-41	16, 17	68G2-1823	19
17-55025-00	5	50-00226-50	16, 17	68G2-8522-1	19
17-55028-00	9	50-00226-501	16	68G2-9072	5, 14, 16
22-02567-00	9	50-00226-65	17	68PD-2-102-3	20, 21
22-02804-00	9	50-00226-66	17	74-50111-00	20
22-50030-00	9	50-01108-00	19	74-50111-01	21
22-50078-02SV	9	50-01110-00	19	74-50111-02	21
22-50222-00	20, 21	50-01110-01	19	74-50111-03	21
34-00300-07	5	50-01114-00	19	76-50013-00	14, 16
34-00302-16	12	50-01115-00	19		
34-00613-07	5	50-01116-00	19	<b>A</b>	
34-00616-00	5, 14, 18	50-01117-00	19	AA06BR293	1
34-01139-00	9	50-01122-01	14	AA06GR232	12
34-01161-00	6, 14, 16	50-01122-02	14	AA06GS228	7
34-01186-00	14, 15	50-01122-04	14	AF55CQ164	5
34-01304-00	6	50-01122-07	15	AU11AR241	14, 18
34-06026-00	9	50-01122-09	15	<b>C</b>	
34-06083-00	6	50-01122-12	15	CA63AA051	12
■ 34-50022-00	1	50-01122-14	15	<b>D</b>	
34-50034-00	16	50-01122-41	14	DD19CA061	1, 12, 20, 21
34-50035-00	16	50-01122-50	14, 15		
40-00060-08	12	50-01122-501	15		
40-00243-01	20, 21	50-01122-65	15		
40-00249-01	20, 21	50-01122-66	15		
40-00520-00	1	50-01122-85	14		
40-00520-01	12	50-01122-86	14		
40-00520-02	1	50-01122-90	15		
40-00520-03	12	50-01122-91	15		
40-00524-00	1	50-01122-93	15		
40-00524-01	12	50-01130-03	17		
40-00528-02	20, 21	50-01130-20	17		
40-01132-00	6	50-01130-21	17		
42-00243-03	9	50-01130-22	17		

Carrier Transport Air Conditioning  
50 Grumbacher Road  
York PA 17406 USA  
Tel: 1-800-673-2431  
Fax: 1-717-764-0401

**North America**  
Carrier Transicold  
700 Olympic Drive  
Athens, GA 30601 USA  
Tel: 1-706-357-7223  
Fax: 1-706-355-5435

**Central America  
and Mexico**  
Ejercito Nacional No. 418  
Piso 9, Torre Yumal  
Col. Chapultepec Morales  
11570 Mexico, D.F.  
Tel: (5255) 9126.0300  
Fax: (5255) 9126.0373



**Carrier**

A United Technologies Company

Carrier Transicold Division,  
Carrier Corporation  
Truck/Trailer Products Group  
P.O. Box 4805  
Syracuse, N.Y. 13221 U.S.A

[www.carrier.transicold.com](http://www.carrier.transicold.com)



A member of the United Technologies Corporation family. Stock symbol UTX  
©2009 Carrier Corporation D Printed in U. S. A. 05/09