



**20 Series Performance Parts Catalog
Bus – 2011/2012**



Build Carrier quality into your bus A/C unit.



Carrier
TRANSICOLD
20 SERIES
PERFORMANCE PARTS

20 Series Bus A/C 2011 Catalog



Build Carrier Quality into your Bus A/C unit.

This catalog has been developed to provide Carrier Transicold dealers and customers easy access to Carrier Transicold Performance Parts available for servicing TK[®], Sutrak USA[®], Trans/Air[®], American Cooling Technology[®] (A.C.T.) and ACC Climate Control[®] bus units.

You already know the benefits of using genuine Carrier replacement parts to service your Carrier units. That same tradition of quality, reliability, and warranty assurance is also available in an ever-expanding line of 20-Series parts.

All 20-Series parts are specified by transport refrigeration engineers. They are then put through field trial testing prior to release to the dealer and end-user customers to insure that fit, form and function meets or exceeds OEM specifications.

20-Series parts come with a nationwide warranty backed by our Carrier Transicold bus dealers and service centers throughout the U.S. and Canada. Contact your local dealer for details.

This catalog is divided into four sections:

Section 1: New Products & Accessories – provides detailed literature on new products and various accessories that we have available.

Section 2: Cross Reference – provides complete part number cross reference in numerical sequence by competitive part number. This section includes TK[®], Sutrak USA[®], Trans/Air[®], American Cooling Technology[®] (A.C.T.) and ACC Climate Control[®] cross references and a photo section of select parts for the convenience of identifying the part you need.

Section 3: Hoses & Fittings – provides a complete guide including photos and specifications to meet all your competitive hose and fittings needs.

Section 4: Coil Cleaners – provides a complete guide to our coil cleaners and chemicals.

We are continuously adding new parts to our 20-Series product line, so if you don't see the part you are looking for in this catalog, contact your local Carrier Transicold dealer to see if it has been added. Thank you for your confidence in Carrier Transicold Performance Parts. If you have any questions regarding information in this catalog or are in need of further assistance, please contact the Performance Parts Customer Service Response Center at (877) 763-0635 or visit us at www.performanceparts.carrier.com.

Table of Contents



Section 1: New Product Overview	1-11
Stainless Steel Replacement Hoses	2
Kidde Fire Extinguishers	4
PowerRush™ Platinum AGM Battery	6
Diablo Refrigerant Recovery Unit	8
Refrigerant Reclaim Units	9
Refrigerant	10
Coil Cleaners	11
Section 2: Competitive Cross Reference	12-69
Thermo King complete parts listing	13-44
TK Bus Component Parts (with photos)	45-47
TK Alternators (with photos)	48
TK Clutches & Components (with photos)	49-51
TK Compressors & Parts (with photos)	52-55
TK Rebuilt Electronics	56
Sutrak USA	57-61
Trans/Air	62-65
American Cooling Technology (A.C.T.)	66-68
ACC Climate Control	69
Section 3: Aeroquip Hoses & Fittings	70-83
Section 4: Coil Cleaners & Chemicals	84-89

New Products and Accessories

Carrier
TRANSICOLD
20 SERIES
PERFORMANCE PARTS

Build Carrier Quality into your Bus A/C unit with these new products.

The New Product and Accessories section is designed to highlight the recent additions to the Performance Parts' 20-Series product line.

This section includes:

- Stainless Steel Replacement Hoses
- PowerRush Platinum AGM Battery
- Kidde Fire Extinguishers
- Diablo Refrigeration Recovery Unit
- Refrigerant Reclaim units
- Refrigerant
- Coil Cleaners



CARRIER TRANSICOLD

20-SERIES PARTS

Stainless Steel Replacement Hoses



Announcing 20-Series Stainless Steel Replacement Hoses

Carrier Transicold’s Performance Parts Group is pleased to announce the addition of stainless steel replacement hoses to our line of Performance Parts 20-Series products.

Braided Steel Refrigerant Hose

Benefits:

- These highly flexible, vibration resistant refrigerant lines are an exact fit as a replacement for OEM hoses.
- Hoses improve system life in high pressure, severe system operating conditions.
- Braided steel construction helps to eliminate refrigerant leaks.

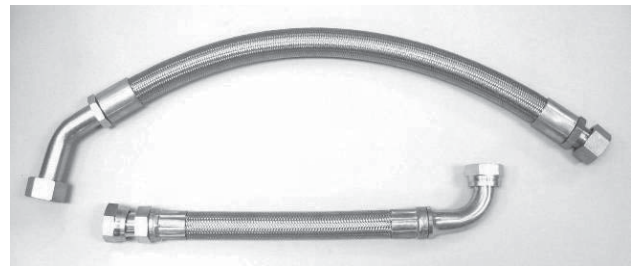

Late Model Nova RTS with RM-40 Systems:	
Carrier P/N	Description
58-50079-00	Suction Hose (#24) OAL 34" w/straight JIC swivel fittings
58-50080-00	Discharge Hose (#16) OAL 36" w/straight JIC swivel fittings

MC96A, MC12 & MC102D w/ 05G Compressor	
Carrier P/N	Description
58-50019-00SS	Receiver Tank Outlet Hose (#12), OAL 34" w/straight JIC swivel fittings
58-50020-00SS	Condenser Outlet Hose (#12), OAL 30" w/straight JIC swivel fittings
58-50021-00SS	Condenser Inlet Hose (#16), OAL 29" w/straight JIC swivel fittings
58-50022-00SS	Comp. Discharge Hose (#16), OAL 24" w/straight & 90 degree JIC swivel fittings
58-50023-00SS	Compressor Suction Hose (#20), OAL 40" w/straight JIC swivel fittings
58-50028-00SS	Filter Drier Hose (#10), OAL 32" w/90 degree JIC swivel fittings

MC96, MC12 & MC102D w/ 05G Compressor & Carrier Evaporator

Carrier P/N	Description
58-50029-00SS	SS Hose (#16), OAL 21.5" w/JIC straight & 90 degree swivel
58-50030-00SS	SS Suction (#20), OAL 37.5" w/straight JIC swivel fitting

MC-9 w/ 05F-30 Compressor

Carrier P/N	Description
58-50031-00SS	Condenser Inlet Hose (#16), OAL 27" w/straight JIC swivel fittings
58-50032-00SS	Condenser Outlet Hose (#12), OAL 30" w/straight JIC swivel fittings
58-50035-00SS	Compressor Discharge Hose (#16), OAL 37" w/straight JIC swivel fittings

Orion V Bus w/Carrier RM-35 Unit

Carrier P/N	Description
58-50092-00	Discharge Hose OAL 48" w/ 2 JIC swivel fittings

ABC / Van Hool (w/Caterpillar C13 engine)

Carrier P/N	ABC Bus P/N	Description
20-10218	10218	SS Suction Hose (#20), OAL 29" w/straight & 90 degree JIC swivel fittings
20-10219	10219	SS Discharge Hose (#16), OAL 23" w/straight & 90 degree JIC swivel fittings

Gillig Bus

Carrier P/N	Gillig P/N	Description
58-50097-00	46-44129-002	SS Compressor Suction Hose (#20) OAL 25" w/ORS straight fittings
58-50098-00	46-38363-022	SS Comp. Discharge Hose (#20), OAL 19" w/ORS straight & 90 degree fittings

Build Carrier Quality into your Bus units.



Kidde

Fire Extinguishers



Protect Your Investment with Heavy Duty Fire Extinguishers

Fire Control Extinguisher Features:

- All fire extinguishers are U.S. DOT and U.S.C.G. approved and are UL Listed.
- Easy-to-read gauge indicates fire extinguisher is charged and ready for use. Gauge allows for immediate pressure status check.
- Supplied with brackets for secure mounting.
- Easy-to-pull safety pin.
- Powder coated cylinder for corrosion protection.
- All extinguishers contain agents that do not need protection from freezing.
- Clear instruction label using graphics to show steps required to operate extinguisher.
- Available in Disposable and Rechargeable units.
- Six-year limited warranty.

Meets Commercial Vehicle Requirements

From the U.S. Department of Transportation:

- One extinguisher with a UL rating of 5-B:C or more, or two extinguishers each with a UL rating of 4-B:C or more.
- One extinguisher with a UL rating of 10-B:C, if the vehicle is transporting placardable quantities of hazardous material.



The Fire Classifications: Types of Fires

A



Common
Combustible



Wood, paper,
textiles, plastic,
rubber, etc.

B



Flammable
liquids



Gasoline,
heptane,
diesel, etc.

C



Electrical
Equipment



Switches,
outlets, etc.

Product Specifications

Carrier Part Number	440161	440162	466423	466425
Model Number	FC10	FC110	FC110M	FC340M
UL Rating	10-B:C	1-A, 10-B:C	1-A, 10-B:C	3-A, 40-B:C
Net agent weight (Average)	2.9 lb.	2.5 lb.	2.6 lb.	5.0 lb.
Unit weight (Average)	3.9 lb.	3.9 lb.	3.9 lb.	7.9 lb.
Diameter (inches)	3.25"	3.25"	3.25"	4.5"
Height (inches)	13.75"	13.75"	15"	16.07"
Discharge time (seconds)	8 - 12	8 - 12	8 - 12	13 - 15
Discharge range (feet)	6 - 8'	6 - 8'	10 - 15'	12 - 18'
Operating pressure	100 psi	100 psi	100 psi	195 psi
Cylinder	Seamless aluminum	Seamless aluminum	Seamless aluminum	Seamless aluminum
Valve, handle, lever	Nylon	Nylon	Metal	Metal



Basic



Disposable Unit:
Replace after 12 years.



Multipurpose



Disposable Unit:
Replace after 12 years.



Multipurpose



Rechargeable Unit



Multipurpose



Rechargeable Unit



PowerRush™ Platinum



The Ultimate Dual Purpose Battery – High Cranking Power and Deep Cycle Capability in One

Exceptional Performance

- Absorbent glass mat (AGM) technology
 - Pure flat-plate lead for maximum power
- Exceptional cold starting performance – 1150 CCA
 - 75% greater power retention vs. Group 31 wet cell batteries at -4°F
- Superior five-second cranking power
 - 40% more power vs. wet-cell batteries
- Long-term shock and vibration resistance for over-the-road, rail, and off-highway applications
 - Welded internal cells withstand extreme vibration
 - Passed extensive long-life tests including IEC 61373 Sections 8-10
- 400 cycle rated to 80% depth of discharge (DOD)

Benefits

- Reduced fuel consumption in Start-Stop mode
 - Fast charge acceptance lessens engine run time for recharging
- Two-year storage life at +77°F (25°C); over 4x greater than traditional wet cells
- 4 Year full-replacement warranty on approved reefer applications in the U.S. and Canada
- 5 – 8 year Service Life
- Maintenance-free
- Fast battery charger available
- Made in the U.S.A.



Specifications

Voltage.....	12 v
Size.....	Group 31
Terminals.....	3/8" stud or SAE post
CCA.....	1150 amps
5 second PCA.....	2150 amps
HCA.....	1545 amps
MCA.....	1370 amps
Reserve capacity.....	205 minutes
Amp hr. @ 20 Hrs.....	100 Ah
Operating temp range..	-40°F (-40°C) to 176°F (80°C)
Weight.....	78 lbs
Part Numbers.....	30-00482-00 SAE Smooth Post 30-00482-01 Threaded Stud

Designed and Built for Long Life over the Long Haul

Traditional wet cell batteries experience a trade-off in high starting power vs. deep cycling ability. The PowerRush Platinum relinquishes nothing, with exceptional performance in both elements, providing piece of mind for your reefer, on-highway, and off-highway battery needs.

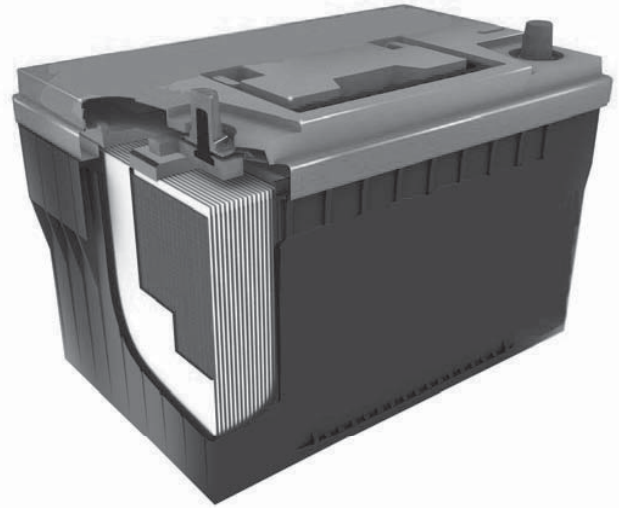

Battery Comparison

	PowerRush Platinum AGM	PowerRush High Cycle Wet Cell	Traditional Wet Cell
CCA	1,150 amps	700 amps	700 amps
Starting Power at -20°F	1,000 amps	560 amps	560 amps
Service Life	5 – 8 Years	20 – 28 Months	20 – 28 months
Warranty	4 Years, or 400 cycles to 80% depth of discharge	18 Months	18 Months
Reserve Capacity	205 Minutes	190 Minutes	180 Minutes
Construction	Pure-lead tin/ Sealed AGM	Lead-Calcium/ Flooded	Lead-Calcium/ Flooded
Corrosion	No terminal or battery compartment corrosion	Likely terminal & battery compartment corrosion	Likely terminal & battery compartment corrosion
Short Circuit	5,000 amps	Hazardous	Hazardous
Shock & Vibration Resistance	Excellent	Good	Fair
Shelf Life (at +77°F)	2 Years	6 Months	1-6 Months
End of Life	Slowly loses power, no catastrophic failure	Immediate loss of power	Immediate loss of power

Diablo

Refrigerant Recovery Unit



Fast and Easy Refrigerant Recovery

Features and Benefits

▪ Fast

- Fastest recovery rates of any residential unit on the market
- Patented ¾ hp Platinum Plus compressor is capable of recovering direct liquid
- Larger 1-1/8" piston allows for movement of greater volumes of refrigerant vs comparable units

▪ Durable

- Larger piston provides the Diablo increased durability and longevity in the field
- Incorporates the latest technology in injection mold design with internal channels increasing airflow across the compressor head and motor

▪ Easy to Operate – Designed with the Technician in Mind!

- Compact with a low center of gravity so it won't slide around in the truck
- Lighter design allows for extra ease of mobility. The Diablo can easily be carried up ladders or stairs to any jobsite
- Simple operation consists of one-line-in, one-line-out technology. Easily self-evacuate the lines to ensure air is not entering the recovery cylinder, then simply switch the valves to recover and go about your work. When recovery is done, evacuate the unit with a switch of the valve to ensure refrigerants are not cross contaminated

▪ Made in the USA







▪ Available at Carrier Transicold Dealers nationwide



Part Number	Description
DIABLO 115V	115 Volt Recovery Unit
DIABLO 240V	240 Volt Recovery Unit

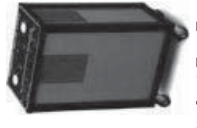

Refrigerant Reclaim Units

	BV-300 Series Reclaimer	JV-90 Series Reclaimer	LV-30 Series Reclaimer	CV-15 Series Reclaimer	RV-10 Series Recovery Unit	VS-29 Series Deep Vacuum
						
	<i>Just Right For Industrial Use</i>	<i>Self-Cleaning Option Available</i>	<i>Perfect For Facility Maintenance & Manufacturing</i>	<i>Designed For Extra Mobility</i>	<i>Unbeatable For Rapid & Numerous Changing of Refrigerants</i>	<i>Great For Pulling To Deep Vacuum Levels</i>
Dimensions	42 in. / 106.7 cm 24 in. / 61.0 cm 60 in. / 152.4 cm	28 in. / 71.1 cm 24 in. / 61.0 cm 60 in. / 152.4 cm	24 in. / 61.0 cm 16 in. / 40.6 cm 41 in. / 104.1 cm	28 in. / 71.1 cm 24 in. / 61.0 cm 45 in. / 114.3 cm	15 in. / 38.1 cm 18.5 in. / 46.9 cm 24 in. / 60.9 cm	20 in. / 50.8 cm 23.5 in. / 59.7 cm 33 in. / 83.8 cm
Weight	725 lbs. / 329 kg	460 lbs. / 209 kg	250 lbs. / 113 kg	223 lbs. / 101 kg	98 lbs. / 44.5 kg	90 lbs. / 40.8 kg
Compressor	2 Horsepower	2 Horsepower	1 Horsepower	1 Horsepower	1/2 Horsepower	1 Horsepower
Electrical	208/230, 60Hz, 1Ph	208/230, 60Hz, 1Ph	115/120, 60Hz, 1Ph	115/120, 60Hz, 1Ph	115/120, 60Hz, 1Ph	115/120, 60Hz, 1Ph
Amperage	20-amp service	20-amp service	15-amp service	15-amp service	10-amp service	10-amp service
Reclaim Capacity	5 lbs. / 2.3 kg Per Minute	5 lbs. / 2.3 kg Per Minute	3 lbs. / 1.4 kg Per Minute	3 lbs. / 1.4 kg Per Minute	1.2 lbs. / .5 kg Per Minute	Not Applicable
On-board Storage	300 lbs. / 136 kg	90 lbs. / 41 kg	30 lbs. / 14 kg	15 lbs. / 7 kg	None	None
Valves	1/4 in. / 6.3 mm SAE (3/8 in. Available)	1/4 in. / 6.3 mm SAE (3/8 in. Available)	1/4 in. / 6.3 mm SAE	1/4 in. / 6.3 mm SAE	1/4 in. / 6.3 mm SAE	1/4 in. / 6.3 mm SAE
Cabinet	Steel Powder Coat	Steel Powder Coat	Steel Powder Coat	Steel Powder Coat	Steel Powder Coat	Steel Powder Coat

Refrigerants

(Not all machines can handle all refrigerants)*
R-12, R-22, R-134a, R-401A, R-401B, R-401C, R-402A, R-402B, R-404A, R-406A, R-407C, R-407D, R-408A, R-409A, R-410A, R-410B, R-411A, R-411B, R-412A, R-414A, R-414B, R-416A, R-500, R-502, R-509 ... and more

Additional Available Equipment:

Sure Safe Storage Systems (Pressure Vessels)
ranging in size from 30 to 300 lbs. / 14 to 136 kg designed with safety and convenience in mind.

Features Include:

- ⇒ Alternate & International Voltages Available
- ⇒ Designed for Years of Dependable Service
- ⇒ Exclusive Patented Liquid Injection
- ⇒ Manufactured to customer's specifications with options to handle R-12, R-22, R-500 & R-502 and all alternates in the same range with one machine utilizing a unique multiple thermal expansion valve design
- ⇒ Measurable Oil Out Of Equipment Being Serviced
- ⇒ Meets All EPA Certification Requirements
- ⇒ UL Approved
- ⇒ Unique Air-Out Purging Feature
- ⇒ Unsurpassed Separation Of Contaminant

Refrigerant



Features and Benefits

- Carrier Transicold Performance Parts can handle all your refrigerant needs
- All Carrier brand refrigerants are American manufactured and meet all ARI700 regulations
- Competitively priced for incredible savings



- For more information about Transicold's refrigerant program and available refrigerants, contact your local Carrier Transicold Dealer

Refrigerant	Container lbs / Type
R-22	125 lb / returnable 50 lb / disposable 30 lb / disposable
R-134a	125 lb / returnable 30 lb / disposable
R-404A	100 lb / returnable 24 lb / disposable
R-401A	125 lb / returnable 30 lb / disposable
R-401B	125 lb / returnable 30 lb / disposable
R-402A	110 lb / returnable 27 lb / disposable
R-407C	25 lb / disposable
R-408A	100 lb / returnable 24 lb / disposable
R-409A	125 lb / returnable 30 lb / disposable
R-502	125 lb / returnable 50 lb / disposable 30 lb / disposable
R-12	145 lb / returnable 50 lb / disposable 30 lb / disposable
R-500	125 lb / returnable 30 lb / disposable



Coil Cleaners



Features and Benefits

- Complete line of coil cleaners and chemicals for all transport refrigeration and air conditioning units

Coil Cleaners

- Nu-brite, CalClean, Tri-power: Biodegradable acidic or alkaline based products are safe yet aggressive! Cleans condenser and evaporator coils restoring lost capacity and operating efficiencies

Coil Protection

- Cal-Shield: Cleans and protects your coil with Teflon. Helps coils resist dirt and grime. Extends coil service life in salt air environments and allows longer periods between cleaning

Insulation Products

- Cork and Foam Insulation Tapes, Insulation sealing plugs and Nufoam (expanding polyurethane), products to meet all your insulation and sealing requirements

Gas Leak Detectors

- Cal-Blue: Detects the smallest leaks due to its high viscosity formula. Non-corrosive to metals and offers freeze protection in -20 degree, 0 degree and 5 degree Fahrenheit

Sprayers

- Pump sprayer for coil cleaners. Available in ½ gallon, 2 gallon and 3 gallon capacities. Made of translucent polyethylene.

- Available from Carrier Transicold Dealers Nationwide



Competitive Cross Reference

Carrier
TRANSICOLD
20 SERIES
PERFORMANCE PARTS

Build Carrier Quality into your Bus A/C unit.

The Cross Reference section provides complete part number cross reference in numerical sequence by competitive part number. This section includes TK, Sutrak USA, Trans/Air, American Cooling Technology and ACC Climate Control unit cross references and a photo section of select parts for the convenience of identifying part you need.

This section includes Cross References on the following competitive product:

- Thermo King
 - Alternators
 - Clutches
 - Compressors
- Sutrak USA
- Trans/Air
- American Cooling Technology (A.C.T.)
- ACC Climate Control

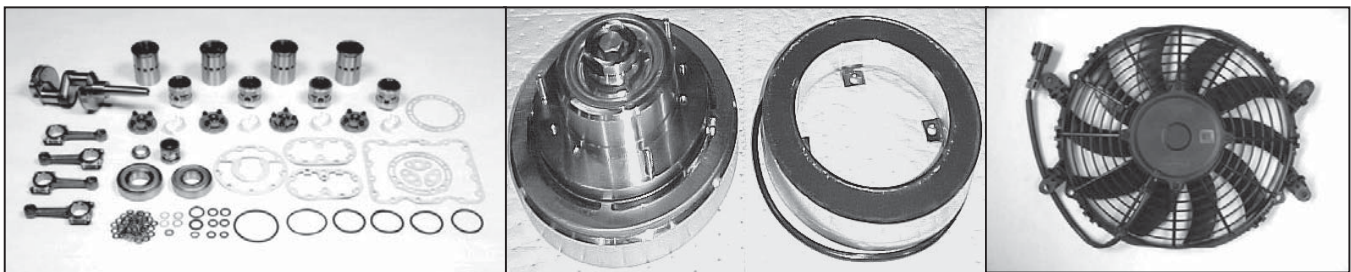

Parts Where Used - Numerical Sequence

TK P/N	CTD P/N	DESCRIPTION	COMPRESSOR				TK BUS UNITS									
			426 Comp	X426 Comp	X430 Compr	X640 Compr	"T" Series	"A" Series	SRT Units	RT Units	VRT Units	LRT Units	Shuttle/Aire			
10 258	20 10 258	FREEZE PLUGS BLOCK C201														
10 259	20 10 259	FREEZE PLUGS HEAD C201														
10 262	20 10 262	FILTER KIT, FUEL PUMP														
10 372	20 10 372	GEAR SET, 2.2DI SE														
11 921	44 00046 08	CAP, FUEL														
11 2501	12 01141 00	FUEL LEVEL GAUGE														
11 2593	12 01141 01	FUEL LEVEL GAUGE														
11 2719	20 11 2719	VALVE, EXHAUST C-201														
11 2727	20 11 2727	VALVE, INTAKE C-201														
11 2760	25 38666 08	NIPPLE														
11 2808	25 38666 07	SPRING - CHECK VALVE														
11 2854	25 38666 16	FILTER - SCREEN														
11 2886	17 13010 00	ACCESS FITTING 1/4" FLARE X 1/8" NPTF														
11 2916	30 00210	CAP, RAIN														
11 2923	25 38666 01	PISTON														
11 2924	25 38666 02	SPRING - PISTON														
11 2929	20 11 2929	COLLAR, SPLIT														
11 3068	30 00134 01	FILTER, SECONDARY FUEL														
11 3331	66U1 2155PK9	FILTER														
11 3356	20 11 3356	FUEL PUMP W/PRIME C201														
11 3365	20 11 3365	NOZZLE, INJECTOR C201														
11 3369	25 35077	SOFT PLUG, CAP SEALING 18MM														
11 3374	20 11 3374	VALVE, GUIDE INLET C201														
11 3375	20 11 3375	VALVE, GUIDE EXHAUST C201														
11 3404	20 11 3404	THRUST WASHER SET C201														
11 3431	20 11 3431	CAMSHAFT C201														
11 3439	20 11 3439	TAPPET C201														
11 3441	20 11 3441	ROCKER ARM, INTAKE C201														
11 3443	20 11 3443	ROCKER ARM, EXHAUST C201														
11 3535	30 00012 02	FILTER, PRE CLEANER														
11 3679	58 00615 01	HOSE OIL DRAIN														
11 3692	20 12 9097	FILTER, FUEL PRIMARY STD														
11 3693	20 12 9098	FILTER, FUEL SECONDARY STD														
11 3845	20 11 3845	BEARING CAM SET C201														
11 4076	20 11 4076	INJECTOR NOZZLE ASSY														
11 4207	20 11 4207	FUEL GAUGE ASSEMBLY														
11 4208	12 00104 03	DIAL, FUEL GAUGE														
11 4254	20 30 197	SEAL KIT, C201 REAR														
11 4414	20 11 4414	VALVE SEALS														

Parts Where Used - Numerical Sequence

TK P/IN	CTD P/IN	DESCRIPTION	COMPRESSOR				TK BUS UNITS									
			426 Comp	X426 Comp	X430 Compr	X640 Compr	"T" Series	"AT" Series	SRT Units	RT Units	VRT Units	LRT Units	Shuttle/Aire			
11 4564	20 11 4564	BY-PASS HOSE														
11 4565	30 00303 00	FILTER, LUBE														
11 4576	20 11 4576SV	PUMP, WATER C-201														
11 4702	30 00106 06	FILTER, WALBORO FUEL PUMP (4-PK)														
11 4744	20 11 4744	RING SET C201 STD														
11 4746	20 11 4746	RING SET .50														
11 4747	20 11 4747	RING SET 1.00														
11 4785	20 11 4785	BEARING SET,MAIN C201 STD														
11 4786	20 11 4786	BEARING SET,MAIN C201 .25														
11 4787	20 11 4787	BEARING SET,MAIN C201 .50														
11 4800	20 11 4800	BEARING SET,MAIN C201 .75														
11 4848	20 11 4848	PISTON ASSY C201 STD														
11 4849	20 11 4849	PISTON ASSY C201 .25														
11 4850	20 11 4850	PISTON C201 .50														
11 4851	20 11 4851	PISTON C201 1.00														
11 5002	20 11 5002	SLEEVE														
11 5006	20 11 5006	BEARING, MAIN REAR YANMAR														
11 5007	20 11 5007	BEARING, MAIN THRUST YANMAR														
11 5012	20 11 5012	VALVE, EXHAUST YANMAR														
11 5016	20 11 5016	GUIDE, INTAKE VALVE YANMAR														
11 5017	20 11 5017	GUIDE, EXHAUST VALVE YANMAR														
11 5028	20 11 5028	BEARING, CAM FRONT YANMAR														
11 5043	20 11 5043	BEARING, ROD STD YANMAR														
11 5051	20 11 7431	INJECTOR VALVE ASSY														
11 5106	20 11 5106	PISTON RINGS														
11 5182	20 11 5182	BEARING, MAIN ADDED ON 3 CYLINDER YANMAR														
11 5186	20 11 5186	ROCKER ARM SHAFT														
11 5248	20 11 5248	PISTON														
11 5313	44 00046 03	CAP, FUEL														
11 5338	20 11 5338	OIL PUMP														
11 5406	20 11 5406	CAP, RADIATOR														
11 5436	20 11 5436	WATER PUMP														
11 5450	20 11 5450	FUEL LEVEL GAUGE														
11 5459	20 11 5459	WRIST PIN BUSHING														
11 5481	20 11 5481	BEARING, FRONT MAIN (BALL) YANMAR														
11 5488	20 11 5488	OIL PUMP ASSY														
11 5629	20 11 5629	SLEEVE C201														
11 5686	20 11 5686	PISTON C201 .75														
11 5744	20 11 5744	BEARING SET, ROD C201 STD														

Parts Where Used - Numerical Sequence

TK P/N	CTD P/N	DESCRIPTION	COMPRESSOR				TK BUS UNITS									
			426 Comp	X426 Comp	X430 Compr	X640 Compr	"T" Series	"A" Series	SRT Units	RT Units	VRT Units	LRT Units	Shuttle/Aire			
11 5745	20 11 5745	BEARING SET, ROD C201 .025														
11 5746	20 11 5746	BEARING SET, ROD C201 .050														
11 5747	20 11 5747	BEARING SET, ROD C201 .075														
11 5779	20 11 5779	VALVE GUIDE, IN+EX ISUZU 2.2 DI														
11 5785	20 11 5785	BEARING SET CAM, ISUZU 2.2 DI														
11 5806	20 11 5806	BEARING SET, MAIN ISUZU 2.2 DI														
11 5807	20 11 5807	BEARING SET, MAIN ISUZU 2.2 DI .025														
11 5811	20 11 5811	THRUST BEARING SET, ISUZU 2.2 DI														
11 5825	20 11 5825	WRIST PIN BUSHING, ISUZU 2.2 DI														
11 5826	20 11 5826	BEARING, ROD ISUZU 2.2 DI STD														
11 5827	20 11 5827	BEARING, ROD ISUZU 2.2 DI 0.25														
11 5833	20 11 5833	WEAR RING, 2.2DI														
11 5838	20 11-5838	RING GEAR														
11 5850	20 11 5850	VALVE, INTAKE ISUZU 2.2 DI														
11 5851	20 11 5851	VALVE, EXHAUST ISUZU 2.2 DI														
11 5861	20 11 5861	HOSE, BYPASS														
11 5869	20 11 5869	NOZZLE, INJECTOR FOR 2.2DI														
11 5887	25 38666 05	TAPPET														
11 5895	25 38666 11	PUMP, HAND PRIMER														
11 5900	20 11 5900	PISTON ASSY, 2.2DI, STD														
11 5901	20 11 5901	PISTON ASSY, 2.2DI, .25MM														
11 5902	20 11 5902	PISTON ASSY, 2.2DI, .50MM														
11 5904	20 11 5904	PISTON ASSEMBLY +1.00 MM (WITH RINGS)														
11 5909	20 11 5909	HOSE, RADIATOR														
11 5946	65 00131 03	CAP, FUEL														
11 5967	20 11 5967	SPEEDI-SLEEVE, YANMAR CRANK REAR														
11 5998	20 11 7500	FUEL PUMP														
11 6005	30 00406 01	INDICATOR, AIR FILTER														
11 6016	29 50052 50	CHECK VALVE KIT														
11 6017	20 11 6017	OIL PUMP, ISUZU 2.2 DI														
11 6023	20 11 6023	RINGS, PISTON (.50MM) 366 YANMAR														
11 6026	20 11 6026	BEARING, MAIN (STD) 3.66 YANMAR														
11 6028	20 11 6028	WASHER, THRUST (STD) 3.66 YANMAR														
11 6033	20 11 6033	BEARING, CAMSHAFT 3.66 YANMAR														
11 6038	20 11 6038	GUIDE, VALVE														
11 6039	20 11 6039	VALVE, INTAKE 3.66 YANMAR														
11 6040	20 11 6040	VALVE, EXHAUST 3.66 YANMAR														
11 6072	20 11 6072	RINGS, PISTON (STD) 366 YANMAR														
11 6073	20 11 6073	RINGS, PISTON (.25MM) 366 YANMAR														

Parts Where Used - Numerical Sequence

TK P/N	CTD P/N	DESCRIPTION	COMPRESSOR				TK BUS UNITS									
			426 Comp	X426 Comp	X430 Compr	X640 Compr	"T" Series	"AT" Series	SRT Units	RT Units	VRT Units	LRT Units	Shuttle/Aire			
11 6077	20 11 6077	BEARING, CONNECTING ROD 3.66 YANMAR														
11 6078	20 11 6078	BUSHING, PIN (STD) 3.66 YANMAR														
11 6090	20 11 6090	WATER PUMP 3.66 YANMAR														
11 6102	20 11 6102	NOZZLE INJECTOR														
11 6182	20 12 6182	FILTER, OIL														
11 6285	20 12 6285	FILTER, FUEL RECTANGLE														
11 6286	20 12 6286	FILTER, FUEL WATER SEPERATOR RECT														
11 6557	20 11 6557	BEARING, MAIN (STD) 3.88 YANMAR														
11 6558	20 11 6558	WASHER, THRUST (STD) 3.88 YANMAR														
11 6568	20 11 6568	VALVE, INTAKE 3.88 YANMAR														
11 6569	20 11 6569	VALVE, EXHAUST														
11 6574	20 11 6574	GUIDE, VALVE														
11 6601	20 11 6601	RINGS, PISTON (STD) 388 YANMAR														
11 6603	20 11 6603	RINGS, PISTON (.25MM) 388 YANMAR														
11 6605	20 11 6605	RINGS, PISTON (.50MM) 388 YANMAR														
11 6606	20 11 6606	BUSHING, PIN (STD) 3.88 YANMAR														
11 6607	20 11 6607	BEARING, CONNECTING ROD 3.88 YANMAR														
11 6845	20 11 6845	SPEEDI SLEEVE FRONT														
11 6863	20 11 6863	SPEEDI SLEEVE FAN SHAFT 1"														
11 6976	20 11 6976	BEARING, CAMSHAFT 3.88 YANMAR														
11 7022	20 11 7022	PISTON ASSY W/RINGS (STD) 366 YANMAR														
11 7023	20 11 7023	PISTON ASSY W/RINGS (.25MM) 366 YANMAR														
11 7024	20 11 7024	PISTON ASSY W/RINGS (.50MM) 366 YANMAR														
11 7025	20 11 7025	PISTON ASSY W/RINGS (STD) 388 YANMAR														
11 7026	20 11 7026	PISTON ASSY W/RINGS (.25MM) 388 YANMAR														
11 7027	20 11 7027	PISTON ASSY W/RINGS (.50MM) 388 YANMAR														
11 7081	20 11 7081	SLEEVE, 2.2 DI ENGINE														
11 7234	20 11 7234	FILTER, PANEL TYPE														
11 7259	20 11 7259	SPEEDI-SLEEVE														
11 7264	20 12 7264	FILTER, FUEL WATER SEPERATOR RECT														
11 7382	20 12 7382	FILTER, DUAL ELEMENT														
11 7400	20 12 7400	FILTER,AIR CLEANER (DRY)														
11 7431	20 11 7431	INJECTOR VALVE ASSY														
11 7433	20 11 7433	FUEL PUMP														
11 7486	20 11 7486	DIPSTICK, OIL														
11 7500	20 11 7500	PUMP, FUEL														
11 7702	25 10391 01	THERMOSTAT, WATER														
11 7757	20 11 7757	INDICATOR, AIR FILTER														
11 7821	20 11 7821	HOSE, OIL DRAIN														

Parts Where Used - Numerical Sequence

TK P/IN	CTD P/IN	DESCRIPTION	COMPRESSOR				TK BUS UNITS									
			426 Comp	X426 Comp	X430 Compr	X640 Compr	"T" Series	"AT" Series	SRT Units	RT Units	VRT Units	LRT Units	Shuttle/Aire			
11 7985	20 11 7985	EXHAUST TUBE														
11 8079	20 11 8079	RING SET, C201, .25MM														
11 8082	20 11 8082	RING SET, 2.2DI, STD														
11 8083	20 11 8083	RING SET, 2.2DI, .25MM														
11 8084	20 11 8084	RING SET, 2.2DI, .50MM														
11 8715	20 11 8715	INJECTOR, 486 YANMAR														
11 8769	20 11 8769	INJECTOR, 374/395														
11 9059	30 60049 20P12	FILTER, AIR														
11 9097	20 12 9097	FILTER, FUEL PRIMARY														
11 9098	20 12 9098	FILTER, FUEL SECONDARY														
11 9099	20 12 9099	FILTER,OIL														
11 9100	20 12 9100	FILTER, OIL EMI														
11 9101	20 12 9101	FILTER, OIL, CASE OF 12														
11 9102	20 12 9102	FILTER, FUEL PRIMARY EMI														
11 9103	20 12 9103	FILTER, FUEL SECONDARY EMI														
11 9182	20 12 9182C	FILTER, EMI OIL , CASE OF 12														
11 9300	20 12 9300	FILTER, AIR														
11 9321	20 12 9321	FILTER, OIL BYPASS, EMI														
11 9338	20 11 9338	VALVE, OIL DRAIN														
11 9341	20 12 9341	FILTER, FUEL, EMI														
11 9341	20 12 9341	FILTER, FUEL "EMI" (CASE OF 12)														
11 9342	20 12 9342C	FILTER, FUEL WATER SEPERATOR w/DRAIN														
11 9356	20 11 9356	WATER PUMP, 2.2 DI														
11 9499	20 11 9499	WATER PUMP, 486 ENGINE														
11 9529	20 11 9529	HOSE, COOLANT														
11 9621	20 11 9621	THERMOSTAT, YANMAR 395														
11 9624	20 11 9624	THERMOSTAT, YANMAR 482/486														
12 145	65 01082 00	TANK, FUEL 50 GALLON														
12 476	20 12 476	MUFFLER														
12 765	20 12 765	MUFFLER														
12 6228	20 12 6228	FILTER, BYPASS OIL														
12 6285	20 12 6285	FILTER, FUEL RECTANGLE														
12 6286	20 12 6286	FILTER, FUEL WATER SEPERATOR RECT														
12 7264	20 12 7264	FILTER, FUEL WATER SEPERATOR RECT														
12 7382	20 12 7382	FILTER, DUAL ELEMENT														
12 7400	20 12 7400	FILTER, AIR 9 PACK														
12 8047	20 12 9342C	FILTER, FUEL WATER SEPERATOR, CASE OF 12														
12 9097	20 12 9097	FILTER, FUEL PRIMARY														
12 9098	20 12 9098	FILTER, FUEL SECONDARY														

Parts Where Used - Numerical Sequence

TK P/N	CTD P/N	DESCRIPTION	COMPRESSOR				TK BUS UNITS								
			426 Comp	X426 Comp	X430 Compr	X640 Compr	"T" Series	"AT" Series	SRT Units	RT Units	VRT Units	LRT Units	ShuttleAire		
12 9099	20 12 9099	FILTER,OIL													
12 9100	20 12 9100	FILTER PKG													
12 9102	20 12 9102	FILTER,FUEL													
12 9103	20 12 9103	FILTER PKG													
12 9190	20 12 9190	FILTER, OIL													
12 9300	20 12 9300	FILTER, AIR, CASE OF 12													
12 9341	20 12 9341	FILTER, FUEL "EMI" (CASE OF 12)													
12 9342	20 12 9342C	FILTER, FUEL WATER SEPERATOR, CASE OF 12													
13 507	20 13 507	WATER PUMP													
13 509	20 13 509	WATER PUMP													
13 924	20 13 924	BEARING, ROD (482 ENGINE)													
20 131	20 20 131	KIT, COMP. CYLINDER HEAD SEALING W/O PLUGS	X	X											
20 169	20 20 169	KIT, X430 LARGE SHAFT CONVERSION													
22 220	20 22 220	BEARING, 214 PUMP END													
22 297	20 22 297	SLEEVE, STD 214 MODEL COMP													
22 306	20 22 306	SCREEN, SUCTION INLET	X	X											
22 306F	20 22 306F	FILTER, SUCTION SOCK 4 CYLINDER COMP	X	X											
22 307	20 22 784	REGULATOR, COMPRESSOR OIL PRESSURE	X	X											
22 313	20 22 313	REED VALVE	X	X											
22 314	20 22 314	WAVE WASHER	X	X											
22 350	20 22 350	SIGHT GLASS, 426, 214, X430 COMPRESSOR	X	X											
22 373	20 22 373	CRANKSHAFT, 2 CYLINDER COMP W/GEAR PUMP													
22 439	20 22 439	CRANKSHAFT 426 FORGED	X												
22 453	20 22 453	REED VALVE PISTON	X	X											
22 552	20 22 552	SUMP, OIL "X" 4 CYLINDER COMPRESSORS		X											
22 554	20 22 554	HOUSING, OIL PUMP X-426 COMPRESSOR		X											
22 555	20 22 555	COVER, OIL PUMP "X" TYPE COMPRESSORS		X											
22 568	20 22 568	CHECK VALVE, COMP SEAL PLATE	X	X											
22 580	20 22 1160	OIL PUMP KIT, TK "X" TYPE COMPRESSOR		X	X										
22 586	20 22 586	CRANKSHAFT X426 FORGED		X											
22 608	20 22 608	SLEEVE,COMP D-214 & X-214													
22 611	20 22 611	PICK UP TUBE, COMPRESSOR OIL		X											
22 639	20 22 639	ROD ASSY,CONN	X	X											
22 653	20 22 653	CHECK VALVE, COMP BETWEEN CYL	X	X											
22 655	20 22 655	CRANKSHAFT X430 FORGED		X											
22 656	20 22 656	SLEEVE,COMP X430		X											
22 660	20 22 660	MANIFOLD, DISCHARGE X-430 COMPRESSOR		X											
22 663	20 22 663	HOUSING, OIL PUMP X-430 COMPRESSOR		X											
22 723	20 22 723	FLANGE, COMPRESSOR		X											

NEW

Parts Where Used - Numerical Sequence

TK P/N	CTD P/N	DESCRIPTION	COMPRESSOR					TK BUS UNITS								
			426 Comp	X426 Comp	X430 Compr	X640 Compr	"T" Series	"AT" Series	SRT Units	RT Units	VRT Units	LRT Units	ShuttleAire			
22 735	20 22 735	MANIFOLD, X430														
22 751	20 22 751	SHAFT SEAL, X426, X430 BUS		X	X	X										
22 777	20 22 777	SHAFT SEAL, X214 COMPRESSOR														
22 778	20 22 778	CRANKSHAFT SEAL	X	X	X	X										
22 784	20 22 784	REGULATOR, COMP OIL PSI	X	X	X	X										
22 786	20 22 786	REED VALVE PISTON	X	X	X	X										
22 787	20 22 787	CHECK VALVE, COMP CENTER LARGE	X	X	X	X										
22 789	20 22 789	CYLINDER HEAD, TK COMP., w/o TAPPED HOLE														
22 790	20 22 790	PLATE		X	X	X										
22 804	20 22 804	CRANKSHAFT, 2 CYL COMP "X" W/GEROTOR PUMP														
22 849	20 22 849	PISTON ASSY, 214, 426, X-426 NEW TYPE	X	X	X	X										
22 850	20 22 850	PISTON ASSY X430 NEW TYPE			X	X										
22 899	20 22 899	SHAFT SEAL, X214 HFC														
22 990	20 22 990	VALVE PLATE ASSY	X	X	X	X										
22 1003	20 22 1003	BEARING SET CONN ROD STD	X	X	X	X										
22 1005	20 22 1005	BEARING SET CONN ROD .010	X	X	X	X										
22 1006	20 22 1006	BEARING SET CONN ROD .020	X	X	X	X										
22 1007	20 22 1007	BEARING SET CONN ROD .030	X	X	X	X										
22 1027	20 22 1027	CRANKSHAFT, LARGE SHAFT X430														
22 1028	20 22 1028	FRONT COVER, X430 LARGE SHAFT COMPRESSOR														
22 1075	20 22 1075	CRANKSHAFT, X426 (LS)														
22 1100	20 22 1100	SEAL, CRANKSHAFT, STAINLESS STEEL BELLOW	X	X	X	X										
22 1101	20 22 1101	SEAL, LARGE SHAFT, STAINLESS STEEL BELLOW														
22 1149	20 22 1149	SHAFT, COMPRESSOR OIL PUMP, "X" TYPE		X	X	X										
22 1160	20 22 1160	OIL PUMP KIT, TK "X" TYPE COMPRESSOR														
22 1181	20 22-1181	OIL SUMP, 7 QUART														
22 1246	20 22 1246	BEARING, ROD, SET (STD)														
22 1265	20 22 1265	BEARING, ROD, SET (.010)														
22 1266	20 22 1266	BEARING, ROD, SET (.030)														
23 122	20 23 122	CRANKCASE, X-426 COMPRESSOR		X												
23 123	20 23 123	CRANKCASE, X-430 COMPRESSOR			X											
30 148	20 30 148	GASKET SET, HEAD C-201														
30 155	66U1 6225	GASKET KIT TXV														
30 173	20 30 173	GASKET KIT YANMAR														
30 174	20 30 174	GASKET KIT YANMAR														
30 175	20 30 175	GASKET SET, C201 ENGINE														
30 196	20 30 196	GASKET KIT D-214														
30 197	20 30 197	SEAL KIT, C201 REAR														
30 235	20 30 235	GASKET SET, 3.74 YANMAR														

NEW

Parts Where Used - Numerical Sequence

TK P/IN	CTD P/IN	DESCRIPTION	COMPRESSOR					TK BUS UNITS								
			426 Comp	X426 Comp	X430 Compr	X640 Compr	"T" Series	"AT" Series	SRT Units	RT Units	VRT Units	LRT Units	ShuttleAire			
30 243	20 30 243	GASKET KIT, X426 & X430		X												
30 247	20 30 247	GASKET KIT, X214														
30 251	20 30 251	GASKET SET, 366 ENGINE														
30 261	20 30 261	GASKET SET, 388 YANMAR ENGINE														
30 262	20 30 262	GASKET SET, 2.2DI ENGINE														
30 263	20 30 263	GASKET SET, TK 482														
30 264	20 30 264	GASKET SET, (486/486E)														
30 276	20 30 276	GASKET KIT, 353 OVERHAUL														
309 615	EK02JA210	FUSIBLE PLUG 210 F														
33 110	20 33 110	GASKET, PUMP HSG D214,426,X426	X	X												
33 115	20 33 115	GASKET, OIL PAN DEEP 426	X													
33 122	20 33 122	GASKET, SEAL PLATE D-214														
33 123	20 33 123	GASKET, THROTTLING VALVE														
33 184	20 33 184	GASKET														
33 199	20 33 2514	GASKET, OIL PAN D-214														
33 200	20 33 2513	GASKET, DRIVE PLATE COMP		X	X											
33 211	20 33 211	GASKET, SUCTION PORT D-214														
33 230	17 44043 02	O-RING, VIBRASORBER														
33 235	20 33 235	O-RING, DUST SEAL, COMP														
33 239	20 33 239	O-RING, OIL GALLEY, COMP	X	X	X											
33 241	20 33 1221	O-RING, THROTTLING VALVE	X	X	X											
33 243	20 33 243	GASKET, SIGHT GLASS 426	X													
33 392	16 03300 00	GASKET, CHECK VALVE														
33 408	20 33 408	O-RING, CYL SLEEVE, COMP	X	X	X											
33 487	20 33 487	GASKET														
33 544	KK71JV013	O-RING														
33 652	20 33 652	GASKET, GEAR CASE														
33 653	20 33 653	GASKET PLUG														
33 672	20 33 672	O-RING, OIL REG, TK COMP	X	X	X											
33 714	20 33 714	GASKET, INJECTION PUMP														
33 726	20 33 726	O-RING, TK COMP	X	X	X											
33 737	20 33 737	GASKET, PUMP COVER 426+214	X													
33 782	20 33 782	O-RING VALVE CVR														
33 792	20 33 792	GASKET HEAD														
33 796	25 10096 00	GASKET WASHER														
33 797	20 33 2535	SEAL, C201 REAR CRANKSHAFT														
33 799	20 33 799	SEAL OIL PAN														
33 820	20 33 820	O-RING, OIL SCREEN 426 COMP	X													
33 928	20 33 928	O-RING														

Parts Where Used - Numerical Sequence

TK P/N	CTD P/N	DESCRIPTION	COMPRESSOR					TK BUS UNITS							
			426 Comp	X426 Comp	X430 Compr	X640 Compr	"T" Series	"AT" Series	SRT Units	RT Units	VRT Units	LRT Units	Shuttle/Aire		
33 1015	42-00243-09	O-RING													
33 1034	17 10812 00	GASKET, PLASTIC SERVICE VALVE CAP													
33 1058	20 33 1058	GASKET FRONT PLATE													
33 1121	20 33 1121	GASKET													
33 1175	20 33 1175	O-RING, OIL PUMP HSG X430			X	X									
33 1221	20 33 1221	O-RING, THROTTLING VALVE													
33 1223	20 33 1223	O-RING, OIL PUMP SHAFT, COMP	X	X	X	X									
33 1238	20 33 1238	SEAL, REAR CLUTCH													
33 1262	20 33-2515	GASKET, OIL PAN DEEP SUMP													
33 1285	20 33 1285	SEAL, FRONT CLUTCH													
33 1290	25 38666 09	O-RING													
33 1491	20 33 1491	O-RING													
33 1506	20 33 1506	SEAL, REAR OIL													
33 1520	20 33 1520	THERMOSTAT GASKET													
33 1527	20 33 1527	WATER PUMP GASKET													
33 1549	20 33 1549	GASKET, OIL PUMP HSG X430			X										
33 1583	07 00237 13	GASKET, 3/8 HOSE FIT													
33 1627	20 33 1627	GASKET, CYLINDER HEAD 2.2DI													
33 1641	25 38667 00	O-RING, LIFT PUMP													
33 1642	20 33 1642	GASKET OIL PAN, 2.2 DI													
33 1646	20 33 1646	O-RING (USED ON 11-5858 WATER PUMP)													
33 1652	25 38666 04	WASHER - PISTON CHAMBER													
33 1653	25 38666 09	O-RING, PRIMER PUMP ALUMINIUM													
33 1656	25 37599 00	O-RING, INJECTOR (2.2DI)													
33 1676	30 01044 21	GASKET, WALBORO FUEL PUMP													
33 1719	20 33 1719	WASHER OIL TUBE													
33 1726	20 33 1726	GASKET HEAD, 3.66 ENGINE													
33 1727	20 33 1727	SEAL, OIL													
33 1732	20 33 1732	SEAL, VALVE STEM													
33 1907	20 33 1907	GASKET, EXHAUST (4 BOLT)													
33 1952	20 33 1952	SEAL, FRONT OIL	X	X	X	X									
33 2019	20 33 2019	O-RING													
33 2043	20 33 2043	O-RING													
33 2044	20 33 2044	SEAL, LIP (214 COMP)													
33 2095	20 33 2095	O-RING (USED ON COMP DRAIN PLUGS)	X	X	X	X									
33 2111	20 33 2805	GASKET, MANIFOLD "WIRE" TYPE													
33 2115	17 31205 00	O-RING TEFLON													
33 2120	20 33 2120	SEAL, LIP (X430 & X426)	X	X	X	X									
33 2134	20 33 2134	SEAL, OIL													

Parts Where Used - Numerical Sequence

TK P/N	CTD P/N	DESCRIPTION	COMPRESSOR				TK BUS UNITS							
			426 Comp	X426 Comp	X430 Compr	X640 Compr	"T" Series	"AT" Series	SRT Units	RT Units	VRT Units	LRT Units	Shuttle/Aire	
33 2205	20 33 2205	O-RING, OIL PICK-UP TUBE	X	X	X	X								
33 2230	20 33 2230	O-RING												
33 2513	20 33 2513	GASKET, DRIVE PLATE COMP.	X	X	X	X								
33 2514	20 33 2514	GASKET, OIL PAN D-214	X	X	X	X								
33 2515	20 33 2515	GASKET, OIL PAN DEEP SUMP	X	X	X	X								
33 2535	20 33 2535	SEAL, C201 REAR CRANKSHAFT												
33 2550	20 33 2550 P10	GASKET, 3 WAY VALVE												
33 2552	20 33 2552	GASKET, HEAD TK COMP GREEN	X	X	X	X								
33 2634	20 33 2634	SEAL, OIL, 2.2DI SE												
33 2738	20 33 2738	GASKET HEAD 3.74 ENGINE												
33 2759	20 33 2759	SEAL, RADIAL, REAR OIL												
33 2767	20 33 2767	GASKET,TK THERMOSTAT UPPER												
33 2768	20 33 2768	GASKET,TK THERMOSTAT LOWER												
33 2805	20 33 2805	GASKET, MANIFOLD "WIRE" TYPE				X								
33 2880	20 33 2880	SEAL, CRANKSHAFT (2.2DI)												
33 2881	20 33 2881	SEAL CRANKSHAFT, C201 FRONT												
33 2935	20 33 2935	GASKET, VALVE COVER, 482/486												
33 2974	20 33 2974	SEAL, AXIAL, REAR OIL,												
33 3004	20 33 3004	SEAL, LIP (X430 LARGE SHAFT COMP)												
33 3096	20 33 3096	GASKET, WATER PUMP												
33 3797	20 33 3797	GASKET, OIL SUMP (7 QT)												
33 3877	20 33 3877	GASKET, OIL LEVEL SENSOR												
33 4088	20 33 4088	SEAL, FRONT OIL, 486 ENGINE												
40 348	12 50040 00	CTM DUAL PROBE												
40 356	20 40 356	THERMOMETER, DIGITAL F W/PROBE												
40 791	20 40 791	SENSOR, UNIVERSAL												
40 871	20 40 871	SENSOR, TEMPERATURE												
40 872	20 40 872	SENSOR KIT, UNGRADED								X				
40 871	20 40 871	SENSOR KIT, GRADED									X			
41 307	20 41 307	SWITCH, PRESSURE												
41 385	20 41 385	SWITCH, OIL PRESSURE												
41 387	20 41 6865	SWITCH, OIL PRESSURE SAFETY												
41 390	10 00316 01	SWITCH, OIL PRESSURE												
41 402	20 41 402SV	SENSOR, OIL LEVEL												
41 740	20 41 740	SENSOR, TEMPERATURE												
41 741	20 40 871	SENSOR, TEMPERATURE												
41 1155	20 41 1155RB	MicroP IV RELAY BOARD, REBUILT												
41 1509	20 41 1509RB	MOTOR CONTROLLER, REPAIRED								X				
41 1514	20 41 1514	DEFROST TERMINATION SWITCH												

NEW

NEW

Parts Where Used - Numerical Sequence

TK P/N	CTD P/N	DESCRIPTION	COMPRESSOR				TK BUS UNITS								
			426 Comp	X426 Comp	X430 Compr	X640 Compr	"T" Series	"AT" Series	SRT Units	RT Units	VRT Units	LRT Units	Shuttle/Aire		
41 1521	20 41 1521	COIL, 12 V													
41 1525	20 41 1525	COIL, 12 V													
41 1740	30 50338 00	REGULATOR, VOLTAGE													
41 1818	20 41 1818	SENSOR, COOLANT LEVEL													
41 2194	30 50345 00	ALTERNATOR, 23 AMP													
41 2195	30 50341 00	ALTERNATOR, 37 AMP													
41 2197	30 50342 00	ALTERNATOR, 65 AMP													
41 2198	30 50337 00	ALTERNATOR, 37 AMP													
41 2200	30 50336 00	ALTERNATOR, 65 AMP													
41 2446	20 41 2446	CONTACTOR													
41 2523	20 41 2523RB	MOTOR CONTROLLER, REPAIRED								X	X				
41 2572	20 41 2572	SOLENOID								X	X				
41 2794	20 41 2794	RELAY, STARTER													
41 3372	20 41 3372	ALTERNATOR, 105 AMP													
41 3590	20 41 3590RB	MOTOR CONTROLLER, REPAIRED								X	X				
41 3627	20 41 3627	ALTERNATOR, 150 AMP, BUS													
41 3669	20 41 3669	SWITCH, HPCO													
41 3987	20 41 3987	SOLENOID, 24 V								X	X				X
41 4022	20 40 871	SENSOR, GRADED													
41 4300	20 41 4300	SENSOR, COMPRESSOR													
41 4306	20 41 4306	SOLENOID, LINEAR													
41 4306	20 41 4306	SOLENOID, LINEAR													
41 4470	20 41 4470	SWITCH, OIL LEVEL													
41 4523	20 41 4523	SWITCH, HPCO													
41 4523	20 41 4523	SWITCH, HPCO													
41 5456	20 41 5456	ALTERNATOR, 120 AMP BOSCH													
41 5457	20 41 5457	ALTERNATOR, 65 AMP													
41 5458	20 41 5458	ALTERNATOR, 37 AMP													
41 6383	20 41 6383	SOLENOID, LINEAR													
41 6539	20 41 6539	SENSOR, ENGINE COOLANT													
41 6582	20 41 6582	GLOW PLUG (TRI-PAK)													
41 6780	20 41 6780	ALTERNATOR, 37 AMP													
41 6781	20 41 6781	ALTERNATOR, 65 AMP													
41 6782	20 41 6782	ALTERNATOR, 120 AMP													
41 6865	20 41 6865	SWITCH, OIL SAFETY													
41 6990	20 41 6990	ALTERNATOR, TRI-PAK (TIER 2 AND AFTER 10/08)													
41 7006	20 41 7006	BLOWER ASSEMBLY, TRIPAK (BEFORE 8/1/05)													
41 7020	20 41 7020	SWITCH, BINARY TRI-PAK													
41 7059	20 41 7059	PUMP, FUEL LIFT													

NEW

NEW

3

NEW

NEW

NEW

Parts Where Used - Numerical Sequence

TK P/N	CTD P/N	DESCRIPTION	COMPRESSOR				TK BUS UNITS									
			426 Comp	X426 Comp	X430 Compr	X640 Compr	"T" Series	"AT" Series	SRT Units	RT Units	VRT Units	LRT Units	Shuttle/Aire			
41 7063	20 41 7063	SWITCH, OIL PRESSURE														
41 7068	20 41 7068	SENSOR, ENGINE COOLANT														
41 7370	20 41 7370	GLOW PLUG														
41 7599	20 41 7599	VALVE, COOLANT														
44 1659	20 44 1659	SWITCH, SAFETY CUTOUT														
44 177	10 00133 00	SWITCH, TOGGLE														
44 440	22 00538 01SV	GAUGE, AMPMETER														
44 490	10 00072 02	SWITCH, TOGGLE														
44 668	22 00518 01	SOCKET, PILOT LIGHT														
44 709	20 44 709	SWITCH														
44 730	20 44 730	CIRCUIT BREAKER														
44 739	66U2 1081	SEAL, BOOT														
44 864	30 00038 04	PLUG, SPARK														
44 984	22 00049 00	LAMP, INCANDESCENT														
44 1093	22 00518 01	SOCKET, PILOT LIGHT														
44 1164	20 44 1164	SWITCH, DEFROST														
44 1357	10 00027 01	SWITCH, TOGGLE														
44 1362	10 01165 00	GAUGE, HOUR METER														
44 1556	20 44 1556	RESISTOR														
44 1634	22 00060 01	FUSE, 30 AMP														
44 1936	10 00071 01	SWITCH, TOGGLE														
44 2039	10 00265 01	REGULATOR, VOLTAGE														
44 2089	20 44 2089	DIAL, GAUGE														
44 2100	10 00072 02	SWITCH, TOGGLE														
44 2152	09 00138 00	ELEMENT														
44 2170	30 00171 28	DIODE ASSY, ISOLATION														
44 2193	30 00171 10	CABLE, ASSEMBLY														
44 2219	30 50001 01	BRUSH SET, ALTERNATOR														
44 2260	12 00136 00	GAUGE, OIL PRESSURE														
44 2286	30 00306 14	FAN														
44 2587	22 15272 00	HOLDER, FUSE														
44 2596	10 00171 09	CIRCUIT BREAKER 15 AMP														
44 2602	20 44 2602	PLUG SOCKET														
44 2756	22 01030 17	DIODE ASSY, RUN/SPEED SOLENOID														
44 2814	20 44 2814	GAUGE, WATER TEMP														
44 2823	10 01095 00	SOLENOID														
44 2847	34 50009 01	PLUNGER ASSY														
44 2853	10 00279 00	CONTACTOR														
44 2911	20 44 2911	SOLENOID														

Parts Where Used - Numerical Sequence

TK P/N	CTD P/N	DESCRIPTION	COMPRESSOR				TK BUS UNITS									
			426 Comp	X426 Comp	X430 Compr	X640 Compr	"T" Series	"AT" Series	SRT Units	RT Units	VRT Units	LRT Units	Shuttle/Aire			
44 2922	20 44 2922	GLOW PLUG														
44 3018	20 44 3018	SWITCH, ENGINE WATER SAFETY														
44 3155	20 44 3155	SWITCH,DEFROST														
44 3183	20 44 3183	SWITCH START PREHEAT														
44 3184	10 01153 00	SOCKET, RELAY														
44 3186	20 44 3186	RELAY,DEFROST														
44 3280	10 01120	RECTIFIER														
44 3325	20 44 3325	ALTERNATOR ASSY 37 AMP														
44 3473	20 44 3473	GAUGE, HOUR METER														
44 3474	12 01039 08	AIR SWITCH														
44 3516	10 00171 09	CIRCUIT BREAKER 25 AMP														
44 3555	12 01039 08	AIR SWITCH														
44 3711	22 01467 00	BULB, WEDGE TYPE														
44 3781	10 01078 01	TRANSFORMER														
44 3842	20 44 3842	DIODE HARNESS														
44 3843	12 50021 00	SWITCH, PRESSURE LOW														
44 3930	20 44 3930	COIL, SOLENOID, 12V														
44 4139	30 00363 19	SLIP RING														
44 4238	10 00171 03	CIRCUIT BREAKER 20 AMP														
44 4258	20 44 4258	SWITCH, PRESSURE														
44 4435	54 00508 30	BRUSHES, GE MOTORS 104-343 & 344														
44 4546	25 32113	CONDENSER														
44 4569	10 00171 09	CIRCUIT BREAKER 15 AMP														
44 4661	22 01131 03	RECEPTACLE														
44 4728	20 44 4728	GLOW PLUG, YANMAR HOSE TYPE														
44 4774	20 44 4774	SWITCH OIL SAFETY														
44 5013	20 44 5013	VOLTAGE REGULATOR														
44 5066	22 02430 00	TERMINAL, FEMALE 1/4 STR														
44 5175	14 50021 02	COIL, MODULATION VALVE														
44 5214	20 44 5214	SOCKET 12 CONTACT														
44 5227	20 44 5227	PLUG 12 CONTACT														
44 5234	20 44 5234	SENSOR, 3000 OHM														
44 5236	20 44 5236	SENSOR														
44 5262	10 01165 00	GAUGE, HOUR METER														
44 5293	10 00171 03	CIRCUIT BREAKER 20 AMP														
44 5305	20 44 5305	SWITCH, HIGH PRESSURE R-12														
44 5310	20 44 5310	SOCKET, 15 CONTACT														
44 5311	20 44 5311	PLUG, 15 CONTACT														
44 5415	10 00316 01	SWITCH														

Parts Where Used - Numerical Sequence

TK P/N	CTD P/N	DESCRIPTION	COMPRESSOR				TK BUS UNITS							
			426 Comp	X426 Comp	X430 Compr	X640 Compr	"T" Series	"AT" Series	SRT Units	RT Units	VRT Units	LRT Units	Shuttle/Aire	
44 5416	20 44 5416	BRUSHES, GE MOTOR					X							
44 5448	20 44 5448	SENSOR												
44 5508	20 44 5508	SWITCH, HIGH PRESSURE R-502												
44 5512	10 00171 12	CIRCUIT BREAKER 30 AMP												
44 5536	10 00301 01	RELAY												
44 5537	10 00302 00	RECEPTICAL (BASE RELAY)					X							
44 5568	20 44 5568	SENSOR, 12' LEAD												
44 5571	10 00286 00	RELAY												
44 5575	10 00171 13	CIRCUIT BREAKER 50 AMP												
44 5585	66U1 7802	GAUGE, HOUR METER, FLANGE TYPE												
44 5633	22 02429 00	TERMINAL, MALE SPADE												
44 5834	20 44 5305	SWITCH, HP								X				
44 5835	22 02392 00SV	CONNECTOR, 2 PIN CAVITY BLACK								X				
44 5836	22 02393 00	TERMINAL, MALE 14-16 AWG								X				
44 5837	22 02394 00	SEAL, CABLE GRAY								X				
44 5838	22 01585 00SV	CONNECTOR, MALE 2 CAVITY BLACK								X				
44 5839	22 01566 00	CONTACT, SOCKET TYPE								X				
44 5847	10 00301 01	RELAY												
44 5857	12 50021 00	SWITCH, LOW PRESSURE												
44 5867	20 44 5867	RESISTOR												
44 5883	22 02393 01	TERMINAL, MALE 18-20 AWG												
44 5896	20 44 5896	SENSOR, MULTITEMP												
44 5985	20 44 5985	THERMOMETER F, MULTITEMP												
44 6008	10 00301 00	RELAY								X				
44 6016	20 44 6016	SENSOR, RPM												
44 6018	20 44 6018	SWITCH, THERMOSTAT												
44 6019	20 44 6019	BOLT THERMISTOR												
44 6047	20 44 6047	RELAY												
44 6132	20 44 6132	SWITCH, LOW PRESSURE												
44 6148	20 44 6148	TIMER DEFROST												
44 6241	12 01039 08	AIR SWITCH												
44 6242	12 01039 08	AIR SWITCH												
44 6257	20 44 6257	ALTERNATOR ASSY, 51 AMP EXT												
44 6263	12 50021 00	SWITCH, LOW PRESSURE								X				
44 6265	12 50022 00	SWITCH, PRESSURE HIGH								X				
44 6307	12 01039 08	AIR SWITCH												
44 6324	22 02394 01	SEAL, CABLE BLUE												
44 6348	20 44 6348	RESISTOR												
44 6368	20 44 6368	ALTERNATOR, 150 AMP, BUS								X				

Parts Where Used - Numerical Sequence

TK P/N	CTD P/N	DESCRIPTION	COMPRESSOR				TK BUS UNITS									
			426 Comp	X426 Comp	X430 Compr	X640 Compr	"T" Series	"A" Series	SRT Units	RT Units	VRT Units	LRT Units	Shuttle/Aire			
44 6424	20 44 6424	SOLENOID, STARTER C-201 "HITACHI"														
44 6463	20 44 6463	MODULE, BATTERY SENTRY														
44 6534	20 44 6534	SENSOR, WATER LEVEL														
44 6544	10 01150 00	SOLENOID														
44 6545	12 01039 08	AIR SWITCH														
44 6553	20 44 6553	TIMER (TK CONTAINER)														
44 6565	20 44 6565	SENSOR														
44 6679	20 44 6679	SOLENOID, STARTER 2.2 DI "HITACHI"														
44 6727	20 44 6727	SOLENOID, FUEL SHUTOFF														
44 6918	20 44 6918	ALTERNATOR, 24V, 150 AMP, BUS														
44 6959	22 01586 00	CONNECTOR, MALE 3 CAVITY														
44 7050	20 44 7050	BRUSHES, MOTOR														
44 7077	12 50019 03	PROBE, 58"														
44 7130	25 36482 01	GLOW PLUG, YANMAR 12 VOLT														
44 7131	20 44 7131	RESISTOR														
44 7172	20 44 7172	MOTOR, DUAL SHAFT, 12 VDC														
44 7192	20 44 7192	SWITCH, STARTER LOCKOUT														
44 7238	20 44 7238	BRUSH RIGGING														
44 7246	20 44 7246	PC BOARD CYCLE SENTRY W/BUZZER														
44 7255	30 00363 21	DIODE, FIELD, ALT														
44 7263	20 44 7263	MODULE, BATTERY SENTRY														
44 7315	30 00363 16	HOUSING, FRONT, ALT														
44 7318	30 00363 20	STATOR														
44 7320	30 00363 25	BRUSH SET, ALTERNATOR														
44 7323	30 00363 15	SPACER, FAN ALT														
44 7370	20 44 7370	GLOW PLUG, 2.2 D.I.														
44 7486	20 44 7486	GAUGE, WATER TEMPERATURE														
44 7531	20 44 7531	TIMER, DEFROST														
44 7553	20 44 7553	COIL, 24 V														
44 7620	20 44 7620	BOOT, RPM SENSOR 44-6016														
44 7711	20 44 7711	SWITCH, HIGH PRESSURE														
44 7774	20 44 7774	CIRCUIT BREAKER, BUTTON RESET														
44 7792	20 44 7792	SWITCH, TOGGLE														
44 7793	20 44 7793	SWITCH, TOGGLE														
44 7816	30 00384 00	FUEL PUMP, FACET (SQUARE)														
44 7929	20 44 7929	SWITCH, TOGGLE														
44 7932	20 44 7932	SWITCH, TOGGLE														
44 8029	20 44 8029	RELAY														
44 8045	20 44 8045	THERMOMETER, DIGITAL F														

Parts Where Used - Numerical Sequence

TK P/N	CTD P/N	DESCRIPTION	COMPRESSOR				TK BUS UNITS									
			426 Comp	X426 Comp	X430 Compr	X640 Compr	"T" Series	"AT" Series	SRT Units	RT Units	VRT Units	LRT Units	ShuttleAire			
44 8244	20 44 8244	FUSIBLE LINK														
44 8276	10 00286 04	RELAY														
44 8400	20 44 8400	THERMISTER BOLT														
44 8526	20 44 8526	MOTOR, KIT														
44 8679	20 44 8679	TIMER, FUEL SAVER & UNLOADER FUEL SAVER														
44 8716	22 02429 00	TERMINAL, MALE SPADE														
44 8764	20 44 8764	METER, HOUR														
44 8883	20 44 8883	SENSOR, OIL PRESSURE														
44 9041	20 44 9041	HARNES, ALTERNATOR														
44 9111	10 00286 03	RELAY														
44 9143	20 44 9143	SOLENOID, BOSCH ALTERNATORS														
44 9181	20 44 9181	SOLENOID														
44 9259	20 44 9259	METER, HOUR														
44 9298	20 44 9298	SENSOR, RPM														
44 9302	20 44 9302	GAUGE, AMMETER -50 TO +50														
44 9336	20 44 9336	HARNES, ALTERNATOR														
44 9408	20 44 9408	SWITCH, HPCO														
44 9468	20 44 9468RB	MicroP IV RELAY BOARD, REBUILT														
44 9571	20 41 5458	ALTERNATOR, BOSCH, 37 AMP														
44 9572	20 41 5457	ALTERNATOR, BOSCH, 65 AMP														
44 9588	20 44 9588	BOLT THERMISTOR														
45 271	20 45 271	COIL, CLUTCH														
45 897	20 45 897	BATTERY BOX, STEEL, WHITE														
45 935	20 45 0935RB	3K THERMOSTAT, REBUILT														
45 954	20 45 0954RB	3K THERMOSTAT, REBUILT														
45 1001	20 45 1001RB	3K THERMOSTAT, REBUILT														
45 1002	20 45 1002RB	3K THERMOSTAT, REBUILT														
45 1003	20 45 1003RB	3K THERMOSTAT, REBUILT														
45 1055	20 45 1055RB	3K THERMOSTAT, REBUILT														
45 1071	20 45 1071RB	3K THERMOSTAT, REBUILT														
45 1083	20 45 1083RB	3K THERMOSTAT, REBUILT														
45 1084	20 45 1084RB	3K THERMOSTAT, REBUILT														
45 1085	20 45 1085RB	3K THERMOSTAT, REBUILT														
45 1086	20 45 1086RB	3K THERMOSTAT, REBUILT														
45 1087	20 45 1087RB	3K THERMOSTAT, REBUILT														
45 1135	20 45 1135RB	3K THERMOSTAT, REBUILT														
45 1227	20 45 1227	COIL, 24 V, BUS CLUTCH														
45 1251	20 45 1251	STARTER, YANMAR 235 & 353														
45 1285	20 45 1285	STARTER, ISUZU C201														

Parts Where Used - Numerical Sequence

TK P/N	CTD P/N	DESCRIPTION	COMPRESSOR				TK BUS UNITS									
			426 Comp	X426 Comp	X430 Compr	X640 Compr	"T" Series	"AT" Series	SRT Units	RT Units	VRT Units	LRT Units	Shuttle/Aire			
45 1300	20 45 1300	BATTERY BOX, SS														
45 1375	20 45 1375RB	3K THERMOSTAT, REBUILT														
45 1389	20 45 1389	COIL, 24V CLUTCH														
45 1440	20 45 1440RB	MicroP IV CONTROLLER, REBUILT														
45 1441	20 45 1441RB	MicroP IV CONTROLLER, REBUILT														
45 1511	20 45 1511RB	MicroP IV CONTROLLER, REBUILT														
45 1512	20 45 1512RB	MicroP IV CONTROLLER, REBUILT														
45 1517	20 45 1517RB	MicroP IV CONTROLLER, REBUILT														
45 1520	20 45 1520RB	MicroP IV CONTROLLER, REBUILT														
45 1521	20 45 1521RB	MicroP IV CONTROLLER, REBUILT														
45 1524	20 45 1524RB	MicroP IV CONTROLLER, REBUILT														
45 1557	20 45 1557RB	MicroP IV CONTROLLER, REBUILT														
45 1558	20 45 1558RB	MicroP IV CONTROLLER, REBUILT														
45 1570	20 45 1570RB	MicroP IV CONTROLLER, REBUILT														
45 1596	20 45 1596RB	MicroP IV CONTROLLER, REBUILT														
45 1597	20 45 1597RB	MicroP IV CONTROLLER, REBUILT														
45 1600	20 45 1600RB	MicroP IV CONTROLLER, REBUILT														
45 1601	20 45 1601RB	MicroP IV CONTROLLER, REBUILT														
45 1676	20 45 1676RB	MicroP IV RELAY BOARD, RAIL UNITS, REBUILT														
45 1688	20 45 1688	STARTER, 486 ENGINES														
45 1718	20 45 1718	STARTER														
45 1791	20 45 1791	HEATER, TK EVAPORATOR (CONTAINER)														
45 1841	20 45 1841RB	MicroP VI CONTROLLER, REBUILT														
45 1930	20 45 1930RB	MicroP VI CONTROLLER, REBUILT														
45 1993	20 45 1993	STARTER, ISUZU 2.2 DI														
45 1993	20 45 1993	STARTER, ISUZU 2.2 DI														
45 1998	20 45 1998	COIL, 24V CLUTCH														
45 2176	20 45 2176	STARTER, TRI-PAK TIER 2														
45 2177	20 45 2177	STARTER, TIER 2 ENGINE														
55 308	40 00102 03	ELBOW, 1/8 MALE PIPE X 1/4 MALE FLARE														
55 370	20 55 370	WASHER, SS COMP SIGHT GLASS														
55 381	20 55 381	O-RING, COPPER TK COMP														
55 386	20 55 386	O-RING, COPPER TK COMP														
55 455	20 55 455	KEY														
55 457	20 55 457	KEY														
55 466	40 00102 03	ELBOW, 1/4 MALE PIPE X 1/4 MALE FLARE														
55 644	40 00102 12	ELBOW, 3/8 MALE PIPE X 1/2 MALE FLARE														
55 664	20 55 664	NUT													X	X
55 692	66U1 6821 2	WASHER														

Parts Where Used - Numerical Sequence

TK P/N	CTD P/N	DESCRIPTION	COMPRESSOR				TK BUS UNITS							
			426 Comp	X426 Comp	X430 Compr	X640 Compr	"T" Series	"AT" Series	SRT Units	RT Units	VRT Units	LRT Units	Shuttle/Aire	
55 895	20 55 895	O-RING, STEEL TK COMP 5/16"	X	X	X	X								
55 896	20 55 896	O-RING, STEEL TK COMP 3/8"	X	X	X	X								
55 1521	44 00045 01	CLAMP, HOSE												
55 1600	30 00171 31P05	KEY, WOODRUFF, ALT												
55 1636	44 00045 05	CLAMP, HOSE												
55 1922	25 38666 13	WASHER - FUEL PIPE												
55 1951	25 38666 10	RING - SNAP												
55 1953	25 38666 03	PLUG												
55 1965	25 38666 14	SCREW - HOLLOW												
55 1983	40 00086 04	FLARE CAP 1/4" PACKAGE OF 10												
55 2042	30 00171 13	NUT, MITG FAN, ALT												
55 2069	44 00045 06	CLAMP, HOSE												
55 2208	20 55 2208	WASHER, BOLT (10 PK)												
55 2459	20 55 2459	WASHER NOZZLE												
55 2669	40 00086 06	CAP, FLARE, KING VALVE, 3/8"												
55 2687	44 00045 15	CLAMP, HOSE												
55 2717	20 55 2717	SNAP RING												
55 2762	34 50009 00	EYE BOLT												
55 2796	44 00045 25	CLAMP, HOSE												
55 3345	20 55 3345	WASHER HEATSHIELD												
55 3451	20 55 3451	STUD, CLUTCH COIL												
55 3534	20 55 3534	WASHER CORRUGATED												
55 3631	20 55 3631	SCREW, 3/8-16 X 3" LONG												
55 4226	34 01226 00	WASHER												
55 4306	20 55 4306	O-RING, COPPER TK COMP												
55 4316	20 55 4316	SCREW, 3/8-16 X 2-3/4" LONG												
55 4979	44 00045 04	CLAMP, HOSE												
55 5094	40 00117 01	DRAIN COCK												
55 5264	DD19CA061	CAP, 1/4 FLARE KNURLED												
55 5283	20 55 5283	SCREW, 3/8-16 X 3-1/4" LONG												
55 5524	25 38666 12	SCREW - HOLLOW												
55 5617	65 00131 02	VENT, FUEL TANK												
55 5672	DD19CA061	CAP, 1/4 FLARE KNURLED												
55 6559	20 55 6559	SCREW, SET												
55 6751	20 55 6751	DRAIN PLUG, COMP MAGNETIC												
55 6752	20 55 6752	PLUG, COMP OIL PUMP												
55 9024	20 55 9024	KEY, COMPRESSOR SHAFT												
55 9031	20 55 9031	SCREW, M12 X 1.75 X 70 MM LONG												
55 9032	20 55 9032	KEY, COMPRESSOR SHAFT												

Parts Where Used - Numerical Sequence

TK P/N	CTD P/N	DESCRIPTION	COMPRESSOR				TK BUS UNITS									
			426 Comp	X426 Comp	X430 Compr	X640 Compr	"T" Series	"A" Series	SRT Units	RT Units	VRT Units	LRT Units	ShuttleAire			
55 9088	20 55 9088	KEY, COMPRESSOR SHAFT, 1.5" LONG														
55 9092	20 55 9092	SCREW, M12 X 1.75 X 80MM LONG														
55 9404	20 55 9404	FITTING, 90° ELBOW-FEMALE O-RING, 3/4-16, HOSE SZ #8														
55 9405	20 55 9405	FITTING, 90° ELBOW-FEMALE O-RING, 7/8-14, HOSE SZ #10														
55 9406	20 55 9406	FITTING, 90° ELBOW-FEMALE O-RING, 1-1/16-14, HOSE SZ #12														
55 9407	20 55 9407	FITTING, 90° ORS FEMALE SWIVEL, 1-1/16-16, HOSE SZ #6														
55 9408	20 55 9408	FITTING, 90° ORS FEMALE SWIVEL, 13/16-16, HOSE SZ #8														
55 9409	20 55 9409	FITTING, 90° ORS FEMALE SWIVEL, 1-14, HOSE SZ #10														
55 9410	20 55 9410	FITTING, 90° ORS FEMALE SWIVEL, 1-14, HOSE SZ #12														
55 9411	20 55 9411	CAGE, -06 HOSE														
55 9412	20 55 9412	CAGE, -08 HOSE														
55 9413	20 55 9413	CAGE, -10 HOSE														
55 9414	20 55 9414	CAGE, -12 HOSE														
55 9415	20 55 9415	CLIP, 18MM, -06 HOSE														
55 9416	20 55 9416	CLIP, 20.5MM, -08 HOSE														
55 9417	20 55 9417	CLIP, 23MM, -10 HOSE														
55 9418	20 55 9418	CLIP, 27.5MM, -12 HOSE														
55 9446	20 55 9446	FITTING, 90° ELBOW-FEMALE O-RING, 5/8-18, HOSE SZ #8														
55 9447	20 55 9447	FITTING, 90° ELBOW-FEMALE O-RING, 3/4-16, HOSE SZ #10														
55 9448	20 55 9448	FITTING, 90° ELBOW-FEMALE O-RING, 7/8-14, HOSE SZ #12														
55 9520	20 55 9520	FITTING, 90° ORS FEMALE SWIVEL, 1-3/16-12, HOSE SZ #12														
55 9521	20 55 9521	FITTING, STRAIGHT, ORS FEMALE SWIVEL, 1-3/16-16, HOSE SZ #8														
55 9522	20 55 9522	FITTING, STRAIGHT, ORS FEMALE SWIVEL, 1-14, HOSE SZ #10														
55 9524	20 55 9524	FITTING, 45° ORS FEMALE SWIVEL, 13/16-16, HOSE SZ #8														
55 9525	20 55 9525	FITTING, 45° ORS FEMALE SWIVEL, 1-14, HOSE SZ #10														
55 9531	20 55 9531	FITTING, STRAIGHT-FEMALE O-RING, 7/8-14, HOSE SZ #10														
55 9535	20 55 9535	FITTING, STRAIGHT-FEMALE O-RING, 3/4-16, HOSE SZ #8														
55 9536	20 55 9536	FITTING, STRAIGHT-FEMALE O-RING, 3/4-16, HOSE SZ #10														
55 9537	20 55 9537	FITTING, STRAIGHT-FEMALE O-RING, 7/8-14, HOSE SZ #12														
55 9596	20 55 9596	FITTING, STRAIGHT, ORS FEMALE SWIVEL, 1-3/16-12, HOSE SZ #12														
55 9600	20 55 9600	FITTING, SPLICER W/HIGH SIDE R134a PORT, HOSE SZ #8														
55 9601	20 55 9601	FITTING, SPLICER W/LOW SIDE R134a PORT, HOSE SZ #10														
55 9602	20 55 9602	FITTING, SPLICER W/LOW SIDE R134a PORT, HOSE SZ #12														
55 9685	20 55 9685	FITTING, STRAIGHT, ORS FEMALE SWIVEL, 1-1/16-16, HOSE SZ #6														
55 9760	20 55 9760	KEY, COMPRESSOR OIL PUMP														
60 147	20 60 147	KIT, 3 WAY VALVE SCREEN														
60 156	20 60 156	STEM KIT 3 WAY VALVE														
60 158	16 00124	SEAT, CHECK VALVE														
60 181	20 60 181	KIT, VALVE REPAIR														

Parts Where Used - Numerical Sequence

TK P/N	CTD P/N	DESCRIPTION	COMPRESSOR				TK BUS UNITS									
			426 Comp	X426 Comp	X430 Compr	X640 Compr	"T" Series	"A" Series	SRT Units	RT Units	VRT Units	LRT Units	Shuttle/Aire			
60 186	20 60 186	KIT, VALVE REPAIR														
60 203	20 60 203	KIT, VALVE REPAIR														
60 246	20 60 246	KIT, VALVE REPAIR														
60 283	20 60 283	KIT, 3 WAY VALVE REPAIR														
60 298	20 60 298	KIT, THROTTLING VALVE REPAIR														
60 300	20 60 300	KIT, VALVE STEM														
61 600	20 68 600	FILTER DRIER (CASE OF 10)														
61 617	20 61 617	HOSE, 50 ft, #6														
61 627	20 61 627	HOSE, 50 ft, #8														
61 637	20 61 637	HOSE, 50 ft, #10														
61 643	20 61 643	HOSE, 50 ft, #12														
61 3316	20 61 3316	DRIER, RECEIVER TRI-PAK														
61 3316LS	20 61 3316-WOS	DRIER, RECEIVER TRI-PAK (WITHOUT BINARY SWITCH)														
61 3596	20 61 3596	CAP, BRASS 3-WAY VALVE														
61 3597	20 61 3597	CAP, BRASS														
61 6467	20 61 3467	GAUGE, THERMOMETER														
66 129	20 66 129	VALVE, SERVICE														
66 376	12 01038 02	GAUGE, THERMOMETER														
66 384	14 00029 04	VALVE, CHECK														
66 508	14 50030 00	FILTER DRIER														
66 527	12 00003 00	GAUGE, COMPOUND R-12														
66 596	16 00124 00	SEAT, CHECK VALVE														
66 814	14 01063 03	FILTER DRIER														
66 1153	16 03002 00	LENS, PLASTIC														
66 1179	14 01068 00	SOLENOID VALVE														
66 1185	20 66 1185	TXV														
66 1224	20 66 1224	VIBERSORBER														
66 1316	20 66 1316	SIGHT GLASS														
66 1409	14 00036 00P10	FILTER DRIER														
66 1587	66U1 3303 1	GAUGE, COMPOUND R-502														
66 1592	20 66 1592	VALVE, CHECK														
66 1723	14 01105 00	FILTER DRIER														
66 1784	73 00328 00	VIBERSORBER														
66 2009	20 66 2009	VALVE, SOLENOID														
66 2020	12 01039 08	AIR SWITCH														
66 2296	17 10812 00	CAP, SERVICE VALVE														
66 3015	17 10806 10	CAP, SERVICE VALVE, BRASS														
66 3253	20 66 3253	VIBRASORBER, DISCHARGE														
66 3379	20 66 5784	VIBRASORBER														

Parts Where Used - Numerical Sequence

TK P/N	CTD P/N	DESCRIPTION	COMPRESSOR				TK BUS UNITS											
			426 Comp	X426 Comp	X430 Compr	X640 Compr	"T" Series	"AT" Series	SRT Units	RT Units	VRT Units	LRT Units	Shuttle/Aire					
66 3467	20 66 3467	VIBRASORBER, DISCHARGE																
66 3576	20 66 3576	VALVE, SUCTION SERVICE																
66 3644	14 00029 04	VALVE, CHECK, 5/8" OD						X										
66 3653	14 00029 06	VALVE, CHECK, 1/4" OD																
66 3656	16 00121 01	CAP, CHECK VALVE																
66 3693	14 01068 00	VALVE, SOLENOID																
66 3974	20 66 3974	VIBRASORBER, DISCHARGE																
66 3994	20 66 3994	VIBRASORBER, DISCHARGE																
66 4284	20 66 4284	HOSE SUCTION																
66 4420	17 21002 01	CAP, CHECK VALVE																
66 4423	20 66 4423	VIBRASORBER, DISCHARGE																
66 4551	20 66 4551	VIBRASORBER, DISCHARGE																
66 4729	14 50033 00	FILTER DRIER																
66 4765	20 66 4765	GAUGE, THERMOMETER																
66 4857	14 50031 00	FILTER DRIER																
66 4858	14 50032 00	FILTER DRIER																
66 4884	20 66 4884	VIBRASORBER, DISCHARGE																
66 4900	14 50034 00	FILTER DRIER																
66 4917	20 66 4917	FILTER, COMPRESSOR OIL																
66 4961	20 66 4961	HOSE, TEFLON																
66 4990	20 66 4990	VIBRASORBER, DISCHARGE																
66 5150	20 66 5150	HOSE, TEFLON																
66 5175	20 66 5175	HOSE, TEFLON																
66 5176	20 66 5176	HOSE, TEFLON																
66 5177	20 66 5177	HOSE, TEFLON																
66 5318	20 66 5318	VALVE, SUCTION SERVICE																
66 5374	20 66 5374	VALVE, SOLENOID																
66 5717	20 66 5717	VIBRASORBER, SUCTION																
66 5784	20 66 5784	VIBRASORBER, DISCHARGE																
66 5788	20 67 9700	FILTER DRIER																
66 5908	20 66 5908	SOLENOID, PILOT																
66 6024	20 66 6024	VIBRASORBER, DISCHARGE																
66 7179	AC302 438	ADAPTER, (FEMALE) QUICK CONNECT (HIGH SIDE)																
66 7181	AC302 439	ADAPTER, (FEMALE) QUICK CONNECT (LOW SIDE)																
66 7392	20 66 7392	VALVE, PRESSURE RELIEF																
66 7636	20 66 7636	SOLENOID, PILOT																
66 7790	20 66 7790	STRAINER, 1.125 DIA. TUBE																
66 7791	20 66 7791	STRAINER, 1.375 DIA. TUBE																
66 7800	20 66 7800	FILTER, COMPRESSOR OIL																

NEW

Parts Where Used - Numerical Sequence

TK P/N	CTD P/N	DESCRIPTION	COMPRESSOR				TK BUS UNITS									
			426 Comp	X426 Comp	X430 Compr	X640 Compr	"T" Series	"AT" Series	SRT Units	RT Units	VRT Units	LRT Units	Shuttle/Aire			
66 7848	20 66 7848	VIBRASORBER, DISCHARGE														
66 8473	20 66 8473	FILTER														
66 8560	20 66 8560	VALVE, SOLENOID														
66 8767	20 66 8767	FILTER DRIER, CONTAINER														
66 9015	20 66 9015	DRIER, FILTER														
66 9200	20 67 9200	FILTER DRIER, 41 CU.IN. ORS														
66 9516	20 66 9516	VALVE, THROTTLING														
66 9700	20 67 9700	FILTER DRIER														
67 404	07 00274 00	OIL SYNTHETIC COMP,6, 1 GALLON JUGS														
67 426	07 00275 00	OIL COMP PETROLEUM 6, 1 GALLON JUGS														
67 1708	20-67-1708	HOSE, 300 ft, #6														
67 1709	20-67-1709	HOSE, 300 ft, #8														
67 1710	20-67-1710	HOSE, 300 ft, #10														
67 1711	20-67-1711	HOSE, 300 ft, #12														
67 4729	14 50033 00	FILTER DRIER														
67 4900	14 50034 00	FILTER DRIER (10 PACK)														
67 5788	20 67 9700	FILTER DRIER														
67 9200	20 68 600	FILTER DRIER, 41 CU.IN. ORS 10 PK														
67 9700	67 9700	FILTER DRIER														
68 600	20 68 600	FILTER DRIER														
70 105	20 70 105	BEARING KIT, BUS CLUTCH														
70 135	20 70-135	BEARING KIT														
70 199	20 70-199	IDLEY PULLEY														
70 214	20 70 214SV	FAN ASSEMBLY, W/HARNES														
77 167	20 77 167	BEARING MAIN DRIVE END	X	X	X	X										
77 169	20 77 169	BEARING MAIN PUMP END	X	X	X	X										
77 671	30 00171 20	BEARING, SEALED, ALT														
77 672	30 00171 17	BEARING, SEALED, ALT														
77 713	16 00128 00	CLUTCH SPRING														
77 960	04 00039 00	BEARING, FLANGE														
77 1070	20 77 1070	BEARING														
77 1082	20 77 1082	NUT, RETAINER														
77 1229	20 77 1229	PULLEY, 2-B / 2-A														
77 1233	20 77 1233	BEARING, BUS CLUTCH														
77 1304	04 50027 01	BEARING														
77 1366	20 77 1366	BOSS PULLEY														
77 1457	20 77 1457	HUB, BUS FAN														
77 1476	20 77 1476	COUPLING, FAN SHAFT														
77 1483	20 77 1483	BLOWER WHEEL														

Parts Where Used - Numerical Sequence

TK P/IN	CTD P/IN	DESCRIPTION	COMPRESSOR				TK BUS UNITS									
			426 Comp	X426 Comp	X430 Compr	X640 Compr	"T" Series	"AT" Series	SRT Units	RT Units	VRT Units	LRT Units	Shuttle/Aire			
77 1484	20 77 1484	BLOWER WHEEL														
77 1487	20 77 1487	NUT, RETAINER														
77 1491	20 77 1491	SPACER														
77 1591	20 77 1591	PULLEY, BOSS (2.2DI)														
77 1609	20 77 2504	COUPLING, COMPRESSOR DRIVE														
77 1672	20 77 1672	PULLEY, 2-5V														
77 1752	20 77 1752	PULLEY, 2-B GROOVE														
77 2003	20 77 2003	PULLEY, IDLER ASSY														
77 2004	20 77 2004	PULLEY, IDLER ASSY														
77 2306	20 77 2306	BEARING, SEALED X426, X430														
77 2355	20 77 2355	PULLEY, 2-5V / 2-2A														
77 2358	20 77-2358	COUPLER STANDARD SHAFT, 8 PIN														
77 2391	20 77 2391	ARMATURE														
77 2392	20 77 2392	ARMATURE														
77 2498	20 77 2498	WASHER														
77 2504	20 77 2504	COUPLING, COMPRESSOR DRIVE														
77 2505	20 77 2505	SPACER														
77 2506	20 77 2506	COUPLER, 8 PIN, LARGE SHAFT COMPRESSOR														
77 2509	20 77 2509	COUPLING, LARGE SHAFT COMPRESSOR														
77 2589	20 77 2589	COUPLING, FAN SHAFT														
77 2613	20 77 2613	SHAFT, PULLEY IDLER														
77 2613	20 77 2613	SHAFT, PULLEY IDLER														
77 2614	20 77-2614	SHAFT														
77 2617	20 77 2617	SHAFT, FAN														
77 2620	20 77-2620	SHAFT														
77 2621	20 77-2621	SHAFT														
77 2748	20 77 2748	BUSHING, DRIVE COUPLER														
77 2856	20 77 2748	BUSHING, DRIVE COUPLER														
78 214	20 78 214	BELT, FAN SHAFT														
78 264	20 78 264	BELT														
78 267	20 78 267	BELT, WATER PUMP W/O TIGHTENER														
78 272	50 00093 00	BELT														
78 278	20 78 278	BELT														
78 287	20 78 287	BELT, FAN SHAFT														
78 315	20 78 315	BELT														
78 321	20 78 321	BELT MAT SET														
78 328	20 78 328	BELT														
78 339	20 78 339	BELT, WATER PUMP WITH TIGHTENER														
78 340	20 78 340	BELT														

Parts Where Used - Numerical Sequence

TK P/N	CTD P/N	DESCRIPTION	COMPRESSOR				TK BUS UNITS									
			426 Comp	X426 Comp	X430 Compr	X640 Compr	"T" Series	"AT" Series	SRT Units	RT Units	VRT Units	LRT Units	Shuttle/Aire			
78 341	50 01121 01	BELT														
78 343	50-01086-01	BELT														
78 344	50-01086-00	BELT														
78 346	20 78 346	BELT / SET OF 2														
78 362	20 78 362	BELT, ALTERNATOR														
78 368	20 78 368	BELT, STANDBY														
78 428	20 78 428	BELT														
78 429	20 78 429	BELT														
78 432	20 78 432	BELT														
78 434	20 78 434	BELT														
78 436	20 78 436	BELT														
78 446	20 78 446	BELT														
78 448	20 78 448	BELT														
78 466	20 78 466	BELT														
78 467	20 78 467	BELT, ALTERNATOR / WATER PUMP														
78 470	20 78 470	BELT, FAN SHAFT X-426														
78 471	20 78 471	BELT, ALTERNATOR & WATER PUMP														
78 486	20 78 486	BELT ENG. TO COMP. XMD R502														
78 494	20 78 494	BELT														
78 495	20 78 495	BELT														
78 498	20 78 498	BELT														
78 500	20 78 500	BELT														
78 513	20 78 513	BELT, TRUCK WATER PUMP														
78 556	20 78 556	BELT														
78 558	20 78-558	FAN, EVAP														
78 585	20 78 585	BELT														
78 591	20 78 591	BELT ENG-COMP MDI SSIV														
78 592	20 78 592	BELT														
78 603	20 78 603	BELT														
78 604	20 78 604	BELT														
78 626	20 78 626	BELT, LND 30 & 50 FAN & ALT														
78 628	20 78 628	BELT, LND WITH ELECTRIC CLUTCH														
78 629	20 78 629	BELT														
78 632	20 78 632	BELT SB 11														
78 656	20 78 656	BELT														
78 666	20 78 666	BELT														
78 667	20 78 667	BELT														
78 668	20 78 668	BELT														
78 669	20 78 669	BELT														

Parts Where Used - Numerical Sequence

TK P/N	CTD P/N	DESCRIPTION	COMPRESSOR				TK BUS UNITS									
			426 Comp	X426 Comp	X430 Compr	X640 Compr	"T" Series	"A" Series	SRT Units	RT Units	VRT Units	LRT Units	ShuttleAire			
78 679	20 78 679	BELT														
78 684	20 78 684	BELT														
78 689	20 78 689	BELT														
78 697	20 78 697	BELT														
78 698	20 78 698	BELT														
78 700	20 78 700	BELT														
78 721	20 78 721	BELT														
78 723	20 78 723	BELT, SET OF 2														
78 731	20 78 731	BELT														
78 747	20 78 747	BELT														
78 751	20 78 751	BELT														
78 757	20 78 757	BELT														
78 765	20 78 765	BELT														
78 766	20 78 766	BELT														
78 767	20 78 767	BELT														
78 773	20 78 773	BELT														
78 784	20 78 784	BELT														
78 785	20 78 785	BELT														
78 787	20 78 787	BELT														
78 800	20 78 800	BELT														
78 805	20 78 805	BELT														
78 809	20 78 809	BELT														
78 826	20 78 826	BELT														
78 827	20 78 827	BELT														
78 835	20 78 835	BELT														
78 837	20 78 837	BELT														
78 841	20 78 841	BELT														
78 842	20 78 842	BELT														
78 843	20 78 843	BELT														
78 844	20 78 844	BELT														
78 845	20 78 845	BELT														
78 890	20 78 890	BELT														
78 896	20 78 896	BELT														
78 898	20 78 898	BELT														
78 899	20 78 899	BELT														
78 900	20 78 900	BELT														
78 905	20 78 905	BELT														
78 928	20 78 928	BELT														
78 929	20 78 929	BELT														

Parts Where Used - Numerical Sequence

TK P/N	CTD P/N	DESCRIPTION	COMPRESSOR				TK BUS UNITS									
			426 Comp	X426 Comp	X430 Compr	X640 Compr	"T" Series	"AT" Series	SRT Units	RT Units	VRT Units	LRT Units	ShuttleAire			
78 936	20 78 936	BELT														
78 941	20 78 941	BELT														
78 977	20 78 977	BELT														
78 983	20 78 983	BELT														
78 1000	20 78 1000	BELT														
78 1012	20 78 1012	BELT														
78 1021	20 78 1021	FAN ASSY, 11", 12V														
78 1026	20 78 1026	BELT														
78 1031	20 78 1031	BELT														
78 1048	20 78 1048	BELT														
78 1051	20 78 1051	BELT														
78 1062	20 78 1062	BELT														
78 1067	20 78 1067	BELT														
78 1083	20 78 1083	BELT														
78 1109	20 78 1341	BELT														
78 1129	20 78 1129	BELT														
78 1134	20 78 1134	BELT														
78 1137	20 78 1137	BELT														
78 1185	20 78 1185	FAN ASSEMBLY, 255MM, 12 VOLT														
78 1263	20 78 1263	BELT														
78 1340	20 78 1340	BELT														
78 1341	20 78 1341	BELT														
78 1351	20 78 1351	BELT														
78 1360	20 78 1360	BELT														
78 1484	20 78 1484	BELT POLYRIB 6 FOR TRI-PAC														
78 1487	20 78 1487	BELT														
78 1487	20 78 1487	BELT														
78 1492	20 78 1492	BELT, COGGED														
91 188	20 91 188	LATCH, DOOR														
91 1199	20 91 1199	BELT GUIDE														
91 2281	20 91 2281	MOUNT, SHOCK														
91 2338	20 91 2338	MOUNT, SHOCK														
91 2619	20 91 2619	MOUNT, SHOCK														
91 2674	20 91 2674	COVER, THERMOSTAT														
91 3095	20 91 3095	BOOT, SOLENOID														
91 3095	20 91-3095	BOOT, SOLENOID														
91 3905	20 91 3905	BEARING DAMPER														
91 4043	20 91 4043	MOUNT, SHOCK														
91 4159	20 91 4159	MOUNT, SHOCK														

Parts Where Used - Numerical Sequence

TK P/N	CTD P/N	DESCRIPTION	COMPRESSOR				TK BUS UNITS									
			426 Comp	X426 Comp	X430 Compr	X640 Compr	"T" Series	"AT" Series	SRT Units	RT Units	VRT Units	LRT Units	Shuttle/Aire			
91 5588	20 91 5588	PLATE, COMPRESSOR DISCHARGE														
91 6146	20 91 6146	HARNES, BATTERY														
91 6670	20 91 6670	AIR FILTER														
91 7709	20 91 7709	MOUNT, SHOCK														
91 9303	20 91 9303	BEZEL, MICRO														
91 9621	20 91 9621	LATCH, DOOR														
91 9621	20 91 9621	LATCH, DOOR														
91 9642	20 91 9642	FILTER, AIR (BUS)														
91 9642	20 91 9642	FILTER PAD WITH FRAME														
98 753	20 98 753	EVAP PANEL														
98 2747	20 98 2747	TOP CAP, SBII														
98 2748	20 98 2748	PANEL, CURBSIDE														
98 3030	20 98 3030	DOOR, SBII ALUMINUM CURB SIDE														
98 3031	20 98 3031	DOOR, SBII ALUMINUM ROAD SIDE														
98 3032	20 98 3032	DOOR														
98 4489	20 98 4489	DOOR, ROAD SIDE														
99 214	34 01235 03	BOLT, 10" X 1/2-13 UNC-2A THD														
99 317	20 99 317	SPRING														
99 630	34 01235 04	BOLT, 6" X 1/2-13 UNC-2A THD														
99 1142	58 01071 00	TUBING, VINYL .18 ID														
99 1175	20 99 6599	LATCH, DOOR														
99 1197	20 99 1197	SPRING														
99 1259	68 03811 00	BRACKET, HANGER														
99 1275	58 00793 00	FITTING, AIR SENSING														
99 1428	20 99 1428	LATCH, DOOR														
99 1433	20 99 1433	MOUNT, SHOCK														
99 1514	30 00175 01	CLAMP, U BOLT														
99 1672	58 50006	BOOT, SOLENOID														
99 1916	20 99 1916	MOUNT, SHOCK														
99 2124	68 03812 00P04	BACKUP PLATE														
99 2127	20 99 2127	HINGE, DOOR LEFT														
99 2128	20 99 2128	HINGE, FRAME RIGHT														
99 2327	20 99 2327	BUSHING, DEFROST DAMPER DOOR														
99 3649	20 99 3649	MOUNT, SHOCK														
99 4482	20 99 4482	ROD, BATTERY HOLD DOWN														
99 4820	20 99 4820	MOUNT, SHOCK														
99 5264	20 99 5264	HINGE														
99 5265	20 99 5265	HINGE														
99 6083	68 03811 00	BRACKET, HANGER, FUEL TANK														

NEW

NEW

Parts Where Used - Numerical Sequence

TK P/N	CTD P/N	DESCRIPTION	COMPRESSOR				TK BUS UNITS								
			426 Comp	X426 Comp	X430 Compr	X640 Compr	"T" Series	"A" Series	SRT Units	RT Units	VRT Units	LRT Units	Shuttle/Aire		
99 6085	68 03812 00	BACKUP, PLATE, FUEL TANK													
99 6545	20 99 6545	PLATE, COMPRESSOR SUCTION													
99 6565	20 99 6565	BEARING													
99 6599	20 99 6599	DOOR LATCH, PLASTIC CURVED END													
99 6900	20 99 6900	DOOR LATCH, PLASTIC FLAT END													
99 7321	20 99 7321	BRACKET, FUEL PUMP MOUNTING													
99 8021	20 99 8021	HINGE, DOOR (SBII SBIII)													
99 8022	20 99 8022	HINGE, DOOR (SBII SBIII)													
99 8029	20 99 8029	HINGE,FEMALE SBII													
99 8103	20 99 8103	STRIKE PLATE, DOOR													
99 8104	20 99 8104	HINGE,MALE LH SBII													
99 8304	20 99 8304	HINGE,MALE RH SBII													
99 8555	20 99 8555	ROD, SOLENOID													
102 870	20 102 870	COMP. TM15, 12V, POLY 8 GROOVE (TRI-PAK)													
104 461	54 50077 00	MOTOR, EVAP, 27 VOLT								X	X				
104 651	54 50077 00	MOTOR, EVAP, 27 VOLT								X	X				
104 652	20 104 652	MOTOR, CONDENSER, 27 VOLT								X	X				
104 740	20 104 740	MOTOR, CONDENSOR								X	X				
104 741	20 104 741	MOTOR, EVAP DUAL SHAFT								X	X				
104 758	20 104 758	MOTOR, EVAP								X	X				
107 150	20 107 150	CLUTCH DRIVE REPAIR KIT								X	X				
107 184	20 107 184	CLUTCH													
107 192	20 107 192	CLUTCH DRIVE REPAIR KIT								X	X				
107 196	20 107 196	CLUTCH													
107 197	20 107 197	CLUTCH													
107 234	20 107 234	CLUTCH													
107 349	20 107 349	CLUTCH, 3 GROOVE TRUCK													
107 341	20 107 341	CLUTCH ASSEMBLY													
107 343	20 107 343	CLUTCH, 8 BUSHING FOR LARGE SHAFT X430 COMPRESSOR													
203 346	07 00260 00	OIL ACID TEST KIT, MINERAL & SYNTHETIC OIL													
203 413	07 00349 00	OIL, POE 35 TRAILER UNITS WITH R-404a													
203 426	07 00354 00	COMPRESSOR OIL, POE 32 CONTAINER UNITS													
203 433	07 00318 00	COMP. OIL, MOBILE POE 22CC (COPELAND COMP)													
203 438	10 01162 00	BATTERY, 12 V													
203 444	07 00337 00	COMPRESSOR OIL ACID TEST KIT FOR POE OIL													
204 244	20 204 244	WRENCH,SIGHT GLASS													
204 290	07 00140	TESTER INJECT NOZZLE													
204 345	07 00259 00	HEAD ASSY, HALIDE LEAK DETECTOR													
204 395	07 00013 02	LEAD THERMISTOR 50F													

Parts Where Used - Numerical Sequence

TK P/N	CTD P/N	DESCRIPTION	COMPRESSOR				TK BUS UNITS								
			426 Comp	X426 Comp	X430 Compr	X640 Compr	"T" Series	"AT" Series	SRT Units	RT Units	VRT Units	LRT Units	ShuttleAire		
204 436	07 00486 00	STROBE LIGHT													
204 442	07 00177	GAUGE, MAGNEHELIC													
204 458	07 00206 01	FLASH TUBE, XENON													
204 476	46 50002 00	GREASE, EXXON N-2 (14 ounce tube)													
204 487	07 00238	REFRIGERATION WRENCH													
204 494	07 00177 01	ASPIRATOR													
204 526	07 00314 00	KIT, GAUGE SET "CFC"													
204 542	07 00179 01	COMPRESSOR TESTER													
204 544	07 00179 07	CHART,COMP (150 - 850 PSI)													
204 548	07 00255 11	ELEMENT, FOR 07-00255-10 CFC LEAK DETECTORS													
204 561	07 00237 06	GAUGE, PRESSURE FOR 07-00314-00 CFC													
204 562	07 00237 05	GAUGE, COMPOUND FOR 07-00314-00 CFC													
204 622	07 00277 00	KIT, STATIC DISSIPATE													
204 622	07 00304 00	STRAP, GROUNDING													
204 623	07 00254 00	PIN, EXTRACTOR AMP CONNECTOR													
204 624	07 00330 00	CRIMPER, ML-2 & ML-2I CONNECTORS													
204 635	07 00298 00	INSERTER (EPROM)													
204 636	07 00297 00	EXTRACTOR (EPROM)													
204 677	AC101 708	HOSE CUTTER TOOL													
204 678	AC101 711	BLADE, HOSE CUTTER TOOL AC101-707													
204 680	07 00240 01	WRENCH, SPANNER FOR CLUTCH ARMATURE													
204 681	AC101 707	CLUTCH TOOL, VARI SPEED COMPRESSOR DKS-26													
204 699	07 00176 11	VACUUM PUMP, 110-115/220-240V 50/60 HZ													
204 713	07 00176 11	VACUUM PUMP, 110-115/220-240V 50/60 HZ													
204 740	07 00315 00	AUTO CHARGING METER													
204 758	07 00294	MANIFOLD GAUGE SET FOR R134a													
204 783	07 00237 04	HANDWHEEL PKG													
204 784	07 00294 01	GAUGE, COMPOUND FOR 07-00294-00 R-134a													
204 785	07 00294 02	GAUGE, PRESSURE FOR 07-00294-00 R-134a													
204 791	07 00307 05	COUPLER QUICK CONN, HIGH SIDE R-134A													
204 792	07 00307 04	COUPLER QUICK CONN, LOW SIDE R-134A													
204 793	07 00301 00	ADAPTER, 1/4" FEMALE FLARE X 1/2" ACME													
204 825	07 00294 05	GAUGE SET (METRIC)													
204 850	07 00307 01	HOSE, (YELLOW) 1/2 ACME X 1/2 ACME BARRIER 72"													
204 851	07 00307 02	HOSE, GAUGE (RED) 1/2 ACME X 14 MM BARRIER 72"													
204 852	07 00307 03	HOSE, GAUGE (BLUE) 1/2 ACME X 14 MM BARRIER 72"													
301 123	14 50037 00	FILTER DRIER T TYPE													
301 124	14 50037 00	FILTER DRIER T TYPE													
301 134	38 00515 00	FILTER, DRIVERS HEATER													

Parts Where Used - Numerical Sequence

TK P/N	CTD P/N	DESCRIPTION	COMPRESSOR				TK BUS UNITS								
			426 Comp	X426 Comp	X430 Compr	X640 Compr	"T" Series	"AT" Series	SRT Units	RT Units	VRT Units	LRT Units	ShuttleAire		
302 153	20 302 153	CRANKSHAFT, GB COMPRESSOR													
303 114	20 303 114	GASKET, HEAD													
303 116	20 303 116	GASKET, DISTRIBUTOR COVER													
303 182	20 303 182	GASKET, OIL PUMP COVER													
303 201	17 10812 00	GASKET, PLASTIC SERVICE VALVE CAP													
303 253	20 33 408	O-RING													
303 266	20 33 726	O-RING													
304 126	10 00302 00	RECEPTICAL (BASE RELAY)													
304 179	10 00303 01	CIRCUIT BREAKER 15 AMP										X			
304 185	10 00303 03	CIRCUIT BREAKER 50 AMP										X			
304 187	10 00303 02	CIRCUIT BREAKER 35 AMP										X			
304 272	20 304 272	COIL, CLUTCH 24 VOLT PITTS													
304 302	10 00300 00	CONTACTOR, N.O.													
304 327	12 00272 01	CONTROLLER, REHEAT													
304 328	12 00272 00	CONTROLLER, CYCLING CLUTCH													
304 357	12 00272 02	CONTROLLER, HEAT ONLY													
304 570	22 01585 00SK	RECEPTICAL, 2 WAY													
304 589	10 00301 00	RELAY													
304 596	10 00286 03	RELAY													
304 636	22 01593 00	RESISTOR, DRIVERS HEATER													
304 648	22 01583 00	RESISTOR, SHORT, EVAP 240 WATTS													
304 649	22 01584 00	RESISTOR, LONG, COND 420 WATTS													
305 191	44 00252 03	CLAMP, HOSE, DRIVERS HEATER													
305 492	20 305 492	SCREW, GB CRANK													
305 549	40 00107 01	TEE, 1/8" FPT X FPT X FPT													
306 115	17 21002 01	VALVE STEM CAP													
306 121	17 10812	CAP, SERVICE VALVE													
306 194	68BH 401 104	COIL, DRIVERS HEATER													
306 217	14 50037 00	FILTER DRIER, T TYPE													
306 255	20 306 255	SIGHT GLASS													
306 267	20 306 615	TXV POWER HEAD													
306 578	EP23SC090	VALVE, OIL DRAIN 90													
306 599	40 00117 01	DRAIN COCK													
306 615	20 306 615	TXV VALVE ASSEMBLY													
306 635	40 00480 00	VALVE, HOT WATER SHUT OFF													
306 640	14 01109 02	VALVE, PRESSURE RELIEF													
306 661	14 01106 00	VALVE, SHUT OFF													
307 116	20 307 116	BEARING, 4GB SEAL END MAIN													
307 117	20 307 117	BEARING, 4GB PUMP END MAIN													

Parts Where Used - Numerical Sequence

TK P/IN	CTD P/IN	DESCRIPTION	COMPRESSOR				TK BUS UNITS									
			426 Comp	X426 Comp	X430 Compr	X640 Compr	"T" Series	"AT" Series	SRT Units	RT Units	VRT Units	LRT Units	Shuttle/Aire			
307 172	20 307 172	CLUTCH 3 GROOVE 3V RG 50MM														
309 615	EK02JA210	FUSIBLE PLUG 210 F														
810 1257	20 10 1257RM	2.2DI; REMAN ENGINE														
810 2647	20 X430LS COMP	COMPRESSOR, REMAN, X430 LARGE SHAFT CRANK														
841 1411	20 41 1411RB	BOARD, TERMINAL, REPAIRED														
841 1544	20 41 1544RB	CONTROLLER, TG-V, IN CAB, REPAIRED														
841 1548	20 41 1548RB	CONTROLLER, TG-V MT, IN CAB, REPAIRED														
841 1812	20 41 1812RB	RELAY BOARD, REPAIRED														
841 2523	20 41 2523RB	CONTROLLER, MOTOR (BUS)														
841 2783	20 41 2783RB	RELAY BOARD, uP MT, REPAIRED														
841 3061	20 41 3061RB	RELAY BOARD, uP VI, REPAIRED														
841 3305	20 41 3305RB	CONTROLLER, TG-V, IN CAB, REPAIRED														
841 3306	20 41 3306RB	CONTROLLER, TG-V, IN CAB, REPAIRED														
841 3307	20 41 3307RB	CONTROLLER, TG-V, IN CAB, REPAIRED														
841 3308	20 41 3308RB	CONTROLLER, TG-V, IN CAB, REPAIRED														
841 3310	20 41 3310RB	CONTROLLER, TG-V, IN CAB, REPAIRED														
841 3411	20 41 3411RB	CONTROLLER, TG-V, IN CAB, REPAIRED														
841 3562	20 41 3562RB	RELAY BOARD, uP MT, REPAIRED														
841 3563	20 41 3563RB	RELAY BOARD, uP MT, REPAIRED														
841 3590	20 41 3590RB	MOTOR CONTROLLER, REPAIRED								X						
841 3727	20 41 3727RB	RELAY BOARD, REPAIRED														
841 4316	20 41 4316RB	BOARD, RELAY														
841 4458	20 41 4458RB	PC BOARD, REPAIRED														
841 5366	20 41 5366RB	PC BOARD, REPAIRED														
841 5457	20 41 5457RM	ALTERNATOR 65 AMP, BOSCH REMAN														
841 5458	20 41 5458RM	ALTERNATOR 37 AMP, BOSCH REMAN														
841 5763	20 41 5763RB	RELAY BOARD, uP MT, REPAIRED														
841 6931	20 41 6931RB	RELAY BOARD, uP MT, REPAIRED														
841 7053	20 41 7053RB	PC BOARD, REPAIRED														
841 7288	20 41 7288RB	RELAY BOARD, uP MT, REPAIRED														
841 733	20 41 733RB	RELAY BOARD, REPAIRED														
841 7423	20 41 7423RB	BOARD, RELAY, REPAIRED														
841 866	20 41 866RB	MODULE, I/O Up IV MT, REPAIRED														
844 3325	20 44 3325RM	ALTERNATOR, REMANUFACTURED														
844 6266	20 44 6266RM	ALTERNATOR, REMANUFACTURED														
844 9865	20 44 9865RB	BOARD, CYCLE SENTRY, REPAIRED														
845 1251	20 45 1251RM	STARTER, REMANUFACTURED														
845 1263	20 45 1263RM	STARTER, REMANUFACTURED														
845 1285	20 45 1285RM	STARTER, REMANUFACTURED														
845 1312	20 45 1312RM	STARTER, REMANUFACTURED														

Parts Where Used - Numerical Sequence

TK P/N	CTD P/N	DESCRIPTION	COMPRESSOR				TK BUS UNITS									
			426 Comp	X426 Comp	X430 Compr	X640 Compr	"T" Series	"AT" Series	SRT Units	RT Units	VRT Units	LRT Units	ShuttleAire			
845 1453	20 45 1453RB	CONTROLLER, uP-A														
845 1463	20 45 1463RB	CONTROLLER, uP														
845 1509	20 45 1509RB	CONTROLLER, REPAIRED														
845 1525	20 45 1525RB	MICRO, uP IV, REPAIRED														
845 1532	20 45 1532RB	CONTROLLER, REPAIRED														
845 1573	20 45 1573RB	PANEL, CONTROL														
845 1579	20 45 1579RB	THERMOSTAT, TG5, REPAIRED														
845 1599	20 45 1599RB	CONTROLLER, REPAIRED														
845 1609	20 45 1609RB	CONTROLLER, uP IV,MT REPAIRED														
845 1610	20 45 1610RB	CONTROLLER, MP4+ W/COMM														
845 1626	20 45 1626RB	REMOTE CONTROL, REPAIRED														
845 1630	20 45 1630RB	CONTROLLER, Up-A+, REPAIRED														
845 1708	20 45 1708RB	CONTROLLER, TG-VI REPAIRED														
845 1724	20 45 1724RM	STARTER, REMANUFACTURED														
845 1731	20 45 1731RB	CONTROLLER, MICRO P IV, REPAIRED														
845 1767	20 45 1767RB	CONTROLLER, TG-VI REPAIRED														
845 1768	20 45 1768RB	CONTROLLER, TG-VIa REPAIRED														
845 1769	20 45 1769RB	CONTROLLER, TG-VIb REPAIRED														
845 1784	20 45 1784RB	CONTROLLER, uP IV,MT REPAIRED														
845 1785	20 45 1785RB	CONTROLLER, uP IV,MT REPAIRED														
845 1790	20 45 1790RB	CONTROLLER, uP IV, REPAIRED														
845 1811	20 45 1811RB	REMOTE CONTROL, REPAIRED														
845 1851	20 45 1851RB	CONTROLLER MPC 2000, REPAIRED														
845 1866	20 45 1866RB	REMOTE CONTROL, REPAIRED														
845 1909	20 45 1909RB	CONTROLLER MPC 3000, REPAIRED														
845 1916	20 45 1916RB	CONTROLLER, uP-D, REPAIRED														

Cross Reference

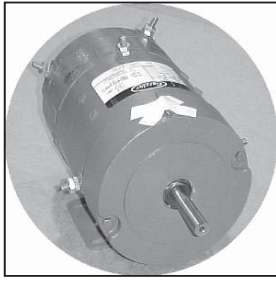

DC Motor, Condenser
TK P/N 104-652
Carrier P/N 20-104652

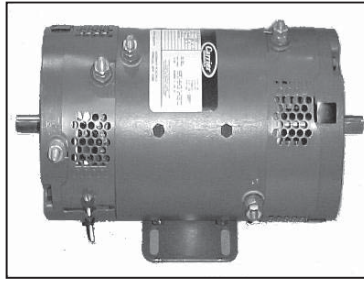

DC Motor, Evaporator
TK P/N 104-651
Carrier P/N 54-50077-00

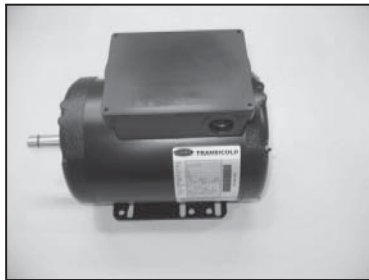

Motor, Condenser
TK P/N 104-740
Carrier P/N 20-104-740



Motor, Evaporator
TK P/N 104-741
Carrier P/N 20-104-741

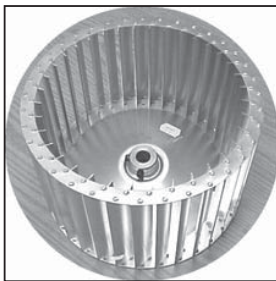

Blower Wheel, CW
TK P/N 77-1483
Carrier P/N 20-77-1483

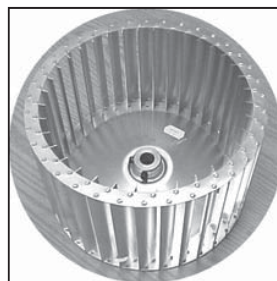

Blower Wheel, CCW
TK P/N 77-1484
Carrier P/N 20-77-1484

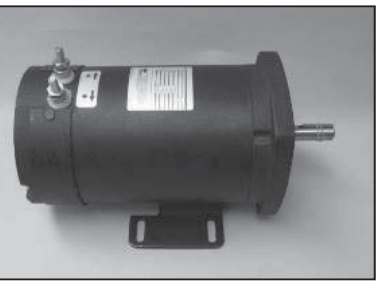

Condenser Motor
TK P/N 104-476
Carrier P/N 20-104-476

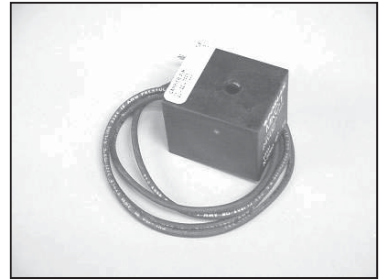

Coil, 24V Solenoid
TK P/N 44-7553
Carrier P/N 20-44-7553

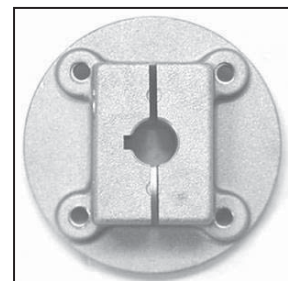

Fan Hub
TK P/N 77-1457
Carrier P/N 20-77-1457

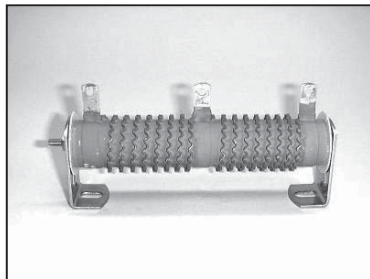

Resistor, .9 Ohm Fixed
TK P/N 44-6348
Carrier P/N 20-44-6348



Resistor, Fan Motor
TK P/N 44-7131
Carrier P/N 20-44-7131

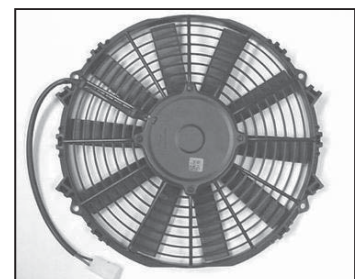

Fan Assy, 12V
TK P/N 78-1021
Carrier P/N 20-78-1021

Thermoking

CARRIER TRANSICOLD

20-SERIES PARTS

Cross Reference



Relay
TK P/N 44-6008
Carrier P/N 10-00301-00

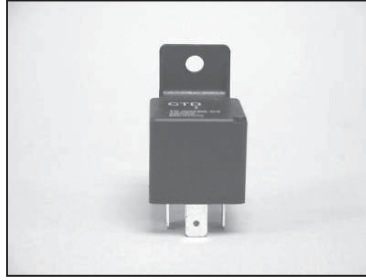

Relay
TK P/N 44-9111
Carrier P/N 10-00286-03

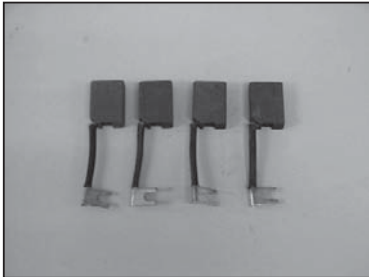

Brush Set, GE Motors
TK P/N 44-5416
Carrier P/N 20-44-5416



Coupling
TK P/N 77-2589
Carrier P/N 20-77-2589

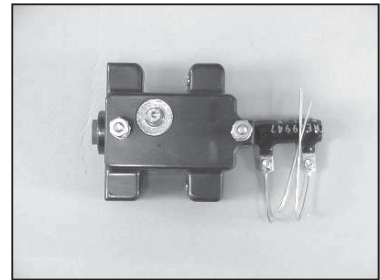

Switch, Safety Cutout
TK P/N 44-1659
Carrier P/N 20-44-1659



Switch, HPCO
TK P/N 41-4523
Carrier P/N 20-41-4523



Air Filter
TK P/N 91-9642
Carrier P/N 20-91-9642



Filter Drier, 41 cu. inch
TK P/N 66-4729
Carrier P/N 14-50033-00



Filter Drier
TK P/N 66-4857
Carrier P/N 14-50031-00



Filter Drier
TK P/N 66-4858
Carrier P/N 14-50032-00



Filter Drier, 41 cu. inch
TK P/N 61-600
Carrier P/N 20-68-600



Water Valve (Transit)
TK P/N 41-7599
Carrier P/N 20-41-7599

CARRIER TRANSICOLD

20-SERIES PARTS

Cross Reference



Relay
TK P/N 41-3987
Carrier P/N 20-41-3987

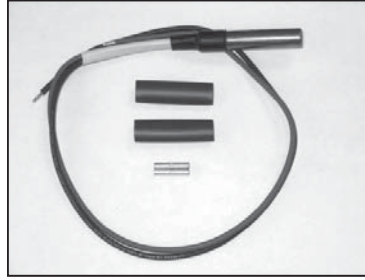

Sensor Kit
TK P/N 40-872
Carrier P/N 20-40-872

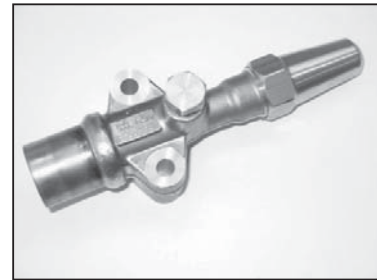

Valve, Suction Service
TK P/N 66-3576
Carrier P/N 20-66-3576

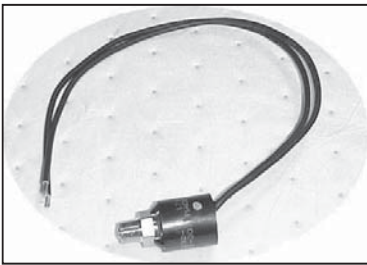

Switch, Pressure
P/N 41-307
Carrier P/N 20-41-307



Switch, Pressure
TK P/N 44-6263
Carrier P/N 20-44-6263



Switch, Pressure
TK P/N 44-6265
Carrier P/N 20-44-4523



Plate, Compressor
TK P/N 22-754
Carrier P/N 20-22-754



Clutch Repair Kit
TK P/N 107-192
Carrier P/N 20-107-192



Clutch Repair Kit
TK P/N 107-150
Carrier P/N 20-107-150



Diode Assembly
TK P/N 44-3842
Carrier P/N 20-44-3842



Bearing Kit
TK P/N 70-105
Carrier P/N 20-70-105



Pulley
TK P/N 77-1672
Carrier P/N 20-77-1672

CARRIER TRANSICOLD

20-SERIES PARTS

Cross Reference

Thermoking

Alternators:

150A, 24 VDC, 24 V Excite

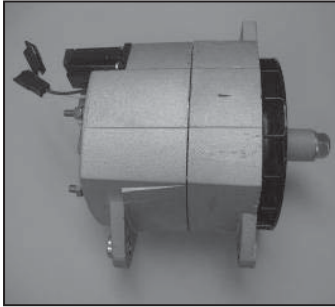

TK P/N 41-3020
Carrier P/N 20-41-3020

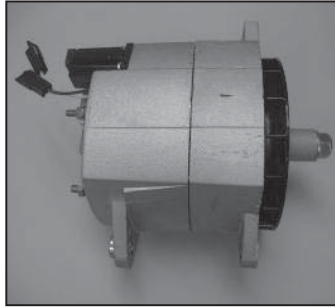

TK P/N 41-2791
Carrier P/N 20-41-2791

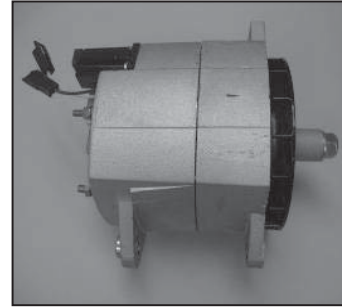

TK P/N 44-6918
Carrier P/N 20-44-6918

Alternators:

150A, 24 VDC, 12 V Excite

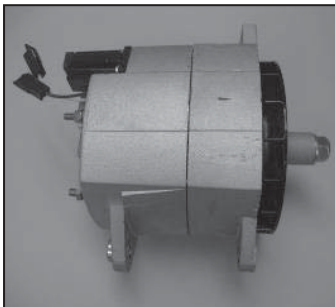

TK P/N 44-6368
Carrier P/N 20-44-6368

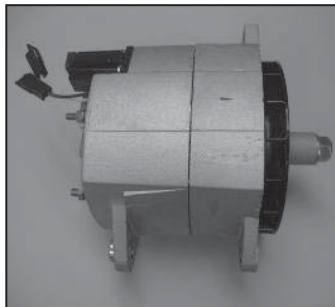

TK P/N 41-3021
Carrier P/N 20-41-3021

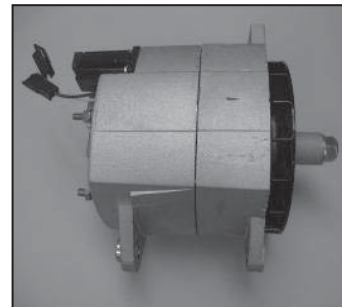

TK P/N 41-3627
Carrier P/N 20-41-3627



Carrier
TRANSICOLD
20 SERIES
PERFORMANCE PARTS

Build Carrier Quality into your TK® Bus units.

All 20-Series parts come with a nationwide warranty backed by our Carrier Transicold bus dealers and service centers throughout the U.S. and Canada.

CARRIER TRANSICOLD

20-SERIES PARTS

Cross Reference

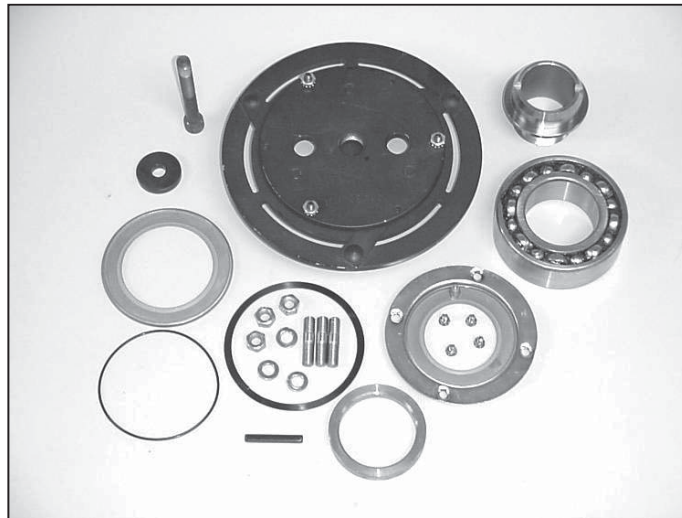

Thermoking

Clutch Repair Kit

TK P/N 107-150

Carrier P/N 20-107-150

(Grease sold separately in 14oz. tubes)

Kit includes: (Items also sold separately)

Armature - P/N 20-77-2521

Bearing - P/N 20-77-1233

Nut retainer - P/N 20-77-1082

Seal, front, w/hardware - P/N 20-33-1285

Seal, rear - P/N 20-33-1238

O-ring - P/N 20-33-928

Snap ring - P/N 20-55-2717

Bolt - P/N 20-55-3631

Washer - P/N 20-77-2498

Studs - P/N 20-55-3451

Clutch Repair Kit

TK P/N 107-192

Carrier P/N 20-107-192

(Grease sold separately in 14oz. tubes)

Kit Includes: (Items also sold separately)

Armature - P/N 20-77-2392

Bearing - P/N 20-77-1233

Spacer - P/N 20-77-1491

Nut retainer - P/N 20-77-1487

Seal, front, w/hardware - P/N 20-33-1285

Seal, rear - P/N 20-33-1238

O-ring - P/N 20-33-928

Snap ring - P/N 20-55-2717

Bolt - P/N 20-55-5283

Washer - P/N 20-77-2498

Studs - P/N 20-55-3451

Key - P/N 20-55-9088

Bearing Kit

TK P/N 70-105

Carrier P/N 20-70-105

(Grease sold separately in 14oz. tubes)

Kit Includes: (Items also sold separately)

Bearing - P/N 20-77-1233

Seal, front - P/N 20-33-1285

Seal, rear - P/N 20-33-1238

O-ring - P/N 20-33-928

Snap ring - P/N 20-55-2717

CARRIER TRANSICOLD

20-SERIES PARTS

Cross Reference



Hub & Armature Assy's
TK P/N 77-2521
Carrier P/N 20-77-2521



Hub & Armature Assy's
TK P/N 77-2392
Carrier P/N 20-77-2392



24V Clutch Coil
TK P/N 45-1227
Carrier P/N 20-45-1227

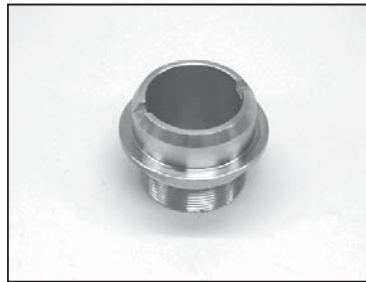

Nut, Retainer
TK P/N 77-1082
Carrier P/N 20-77-1082

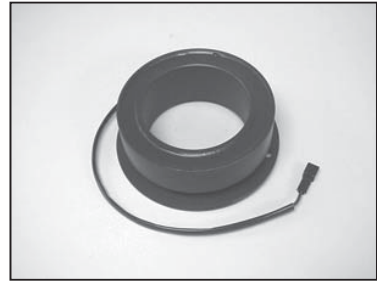

24V Clutch Coil
TK P/N 45-271
Carrier P/N 20-45-271

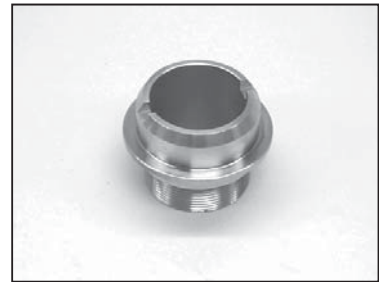

Nut, Retainer
TK P/N 77-1487
Carrier P/N 20-77-1487



Rear Seal
TK P/N 33-1238
Carrier P/N 20-33-1238



Front Seal
TK P/N 33-1285
Carrier P/N 20-33-1285



Bearing
TK P/N 77-1233
Carrier P/N 20-77-1233

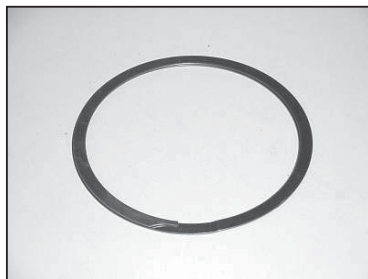

Snap Ring
TK P/N 55-2717
Carrier P/N 20-55-2717



Spacer
TK P/N 77-1491
Carrier P/N 20-77-1491



Stud
TK P/N 55-3451
Carrier P/N 20-55-3451

Thermoking

CARRIER TRANSICOLD

20-SERIES PARTS

Cross Reference

Thermoking



Clutch, Vapor/TK
 Vapor P/N CLU-035
 TK P/N 307-172
 Carrier P/N 20-307-172

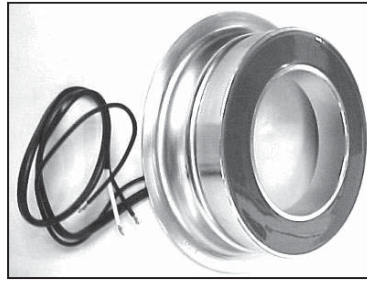

24V Coil, Vapor/TK
 Vapor P/N COL-2126
 TK P/N 304-272
 Carrier P/N 20-304-272



These pulleys are machined from high quality billet steel and powder painted to give you maximum life.

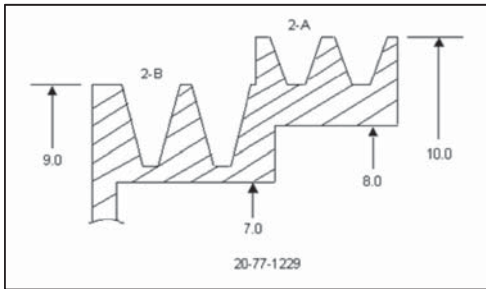

Pulley, 2-B / 2-A
 TK P/N 77-1229
 Carrier P/N 20-77-1229

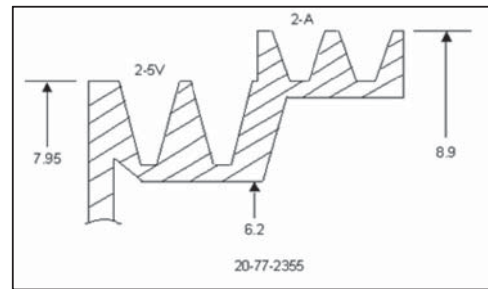

Pulley, 2-5V / 2-2A
 TK P/N 77-2355
 Carrier P/N 20-77-2355

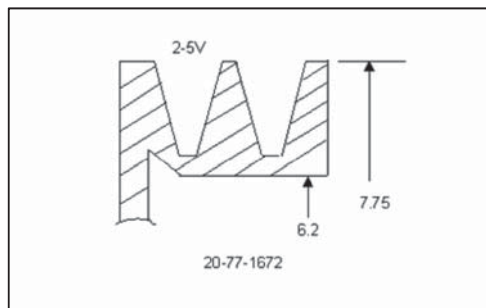

Pulley, 2-5V
 TK P/N 77-1672
 Carrier P/N 20-77-1672

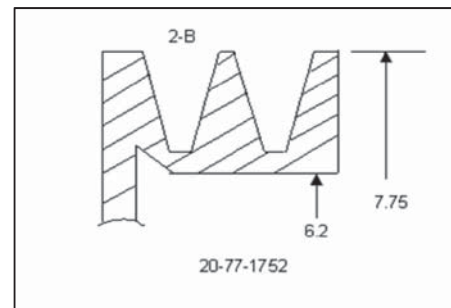

Pulley, 2-2B
 TK P/N 77-1752
 Carrier P/N 20-77-1752

Cross Reference

Thermoking

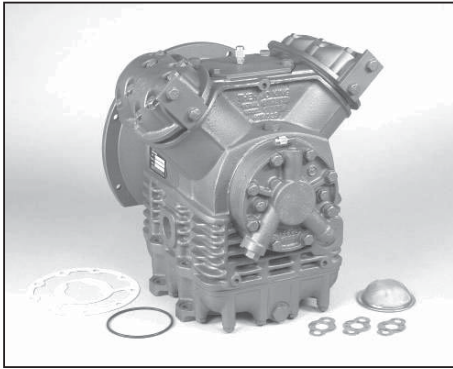

Replacement Compressors for HFC & HCFC Applications:

X430 Compressor - P/N 20-X430-COMP

X426 Compressor - P/N 20-X426-COMP

Replacement Bus Compressors:

X426 Compressor w/hub - P/N 20-X426-BUS

X430 Compressor w/hub - P/N 20-X430-BUS

•Includes drive plate & stainless steel crankshaft seal.

These compressors are not just repaired, they are totally rebuilt.

New parts include:

Pistons, Connecting rods, Sleeves, Valve plates, Discharge valves, Crankshaft, Main bearings, Rod bearings, Shaft seal, Gaskets & O-rings.



Compressor Rebuild Kits

X430 Compressor

P/N 20-20-X430-WC (with crank & rods)

P/N 20-20-X430-WOC (without crank & rods)

X426 Compressor

P/N 20-20-X426-WC (with crank & rods)

P/N 20-20-X426-WOC (without crank & rods)

Kits for rebuilding small shaft compressors being used in **R407C and R134a** systems. They include the 20-77-2306 sealed bearing and 20-22-1100 metal bellows shaft seal.

X430 Compressors

P/N 20-20-X430HP-WC (with crank & rods)

P/N 20-20-X430HP-WOC (without crank & rods)

X426 Compressors

P/N 20-20-X426HP-WC (with crank & rods)

P/N 20-20-X426HP-WOC (without crank & rods)

Cross Reference

Thermoking

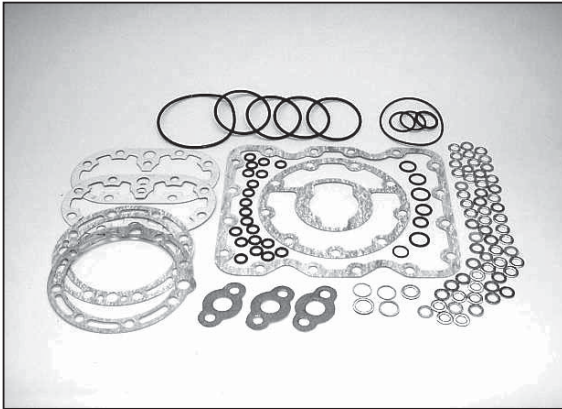

Gasket Kits

X430 & X426
Compressors
TK P/N 30-243
Carrier P/N 20-30-243



X430 Piston
TK P/N 22-850
Carrier P/N 20-22-850



X426 Piston
TK P/N 22-849
Carrier P/N 20-22-849



Connecting Rod
TK P/N 22-639
Carrier P/N 20-22-639



X430 Sleeve
TK P/N 22-656
Carrier P/N 20-22-656



X426 & 426 Sleeve
TK P/N 22-297
Carrier P/N 20-22-297

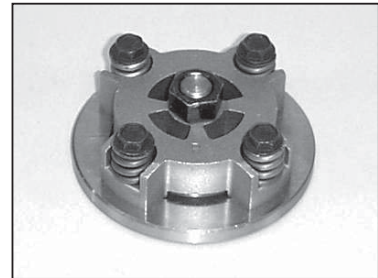

Valve Plate
TK P/N 22-990
Carrier P/N 20-22-990

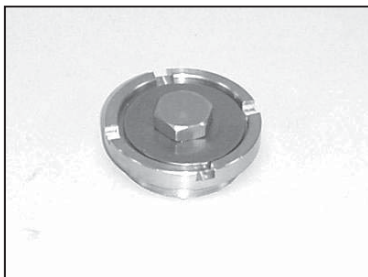

Check Valve
TK P/N 22-787
Carrier P/N 20-22-787



Pressure Regulator
TK P/N 22-784
Carrier P/N 20-22-784

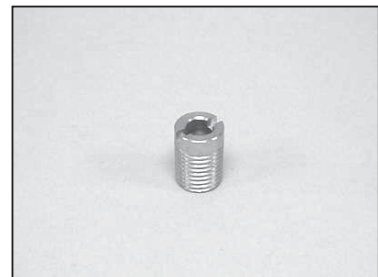

Check Valve
TK P/N 22-568
Carrier P/N 20-22-568

CARRIER TRANSICOLD

20-SERIES PARTS

Cross Reference

Thermoking



Check Valve
TK P/N 22-653
Carrier P/N 20-22-653

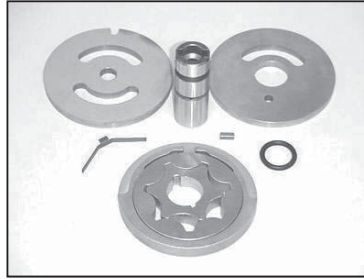

Oil Pump (X430 & X426)
TK P/N 22-1160
Carrier P/N 20-22-1160

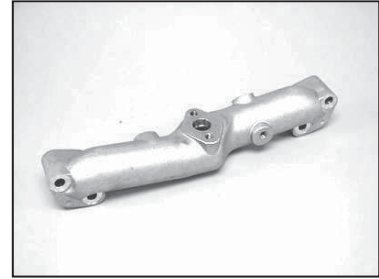

Manifold
TK P/N 22-660
Carrier P/N 20-22-660

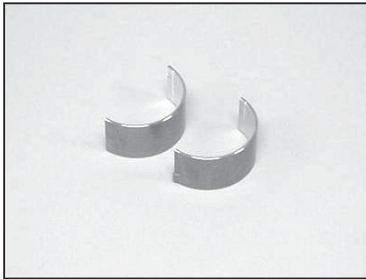

Bearings, Connecting Rod
Standard - P/N 20-22-1246
.010" Over P/N 20-22-1265
.020" Over P/N 20-22-1266
.030" Over P/N 20-22-1007

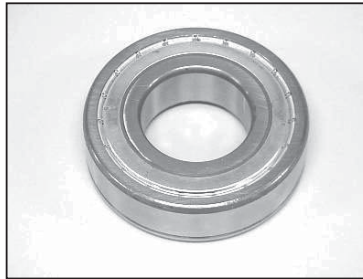

Bearings, Crankshaft
P/N 20-77-167 Drive End
P/N 20-77-169 Pump End
P/N 20-77-2306 Sealed

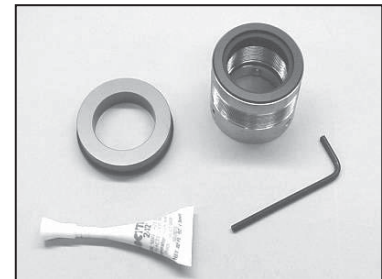

Shaft Seals, Metal Bellows
TK P/N 22-751
Carrier P/N 20-22-751

TK P/N 22-1100
Carrier P/N 20-22-1100



Shaft Seal, Rubber Bellows
TK P/N 22-778
Carrier P/N 20-22-778

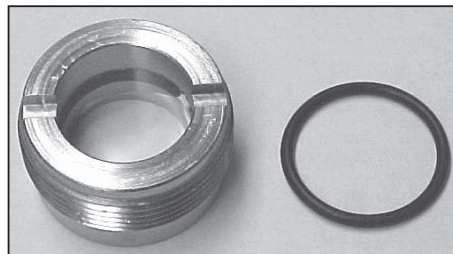

Sight Glass w/O-ring
TK P/N 22-350
Carrier P/N 20-22-350



Sight Glass Wrench
3/8" Drive
P/N 20-204-244

Cross Reference



Crankshaft (X430)
TK P/N 22-655
Carrier P/N 20-22-655

Thermoking



Crankshaft (X426)
TK P/N 22-586
Carrier P/N 20-22-586

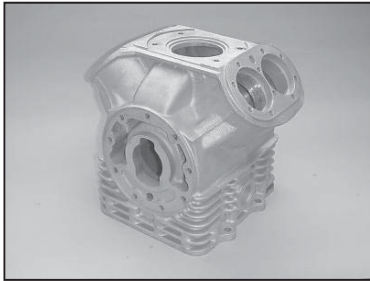

X430 Crankcase
TK P/N 23-123
Carrier P/N 20-23-123

X426 Crankcase
TK P/N 23-122
Carrier P/N 20-23-122

*When you need it
done right...*

Turn to the Experts.



Contact your local dealer
or visit us at
www.transportparts.carrier.com
to find a dealer near you.

Carrier
TRANSICOLD
**PERFORMANCE
PARTS**

Cross Reference

Rebuilt Electronics



Motor Drive Controller

DESCRIPTION	TK P/N	CTD P/N
Drive, Motor Controller	41 1509	20 41 1509RB
Drive, Motor Controller	41 2523	20 41 2523RB
Drive, Motor Controller	41 3590	20 41 3590RB

ONE YEAR WARRANTY ON ALL OUR REPAIRED ELECTRONICS

SEND US YOUR MIRCO'S AND START SAVING!

CALL YOUR LOCAL CARRIER TRANSICOLD DEALER FOR DETAILS

Cross Reference

Sutrak USA

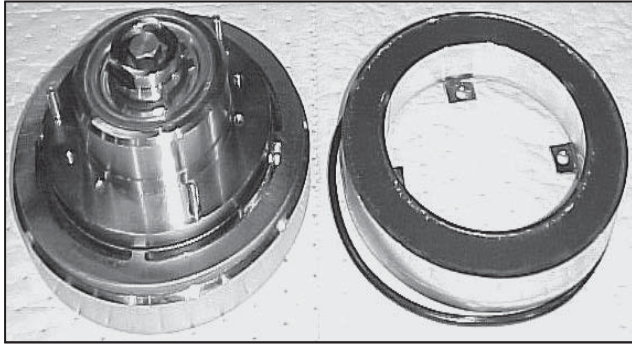

Clutch Assembly (clutch & coil)
Sutrak USA P/N - 554.142
Carrier P/N - 20-554-142

Clutch Only
Sutrak USA P/N - 554.138
Carrier P/N - 20-554-138

Coil Only (24V)
Sutrak USA P/N - 554.264
Carrier P/N - 20-554-264

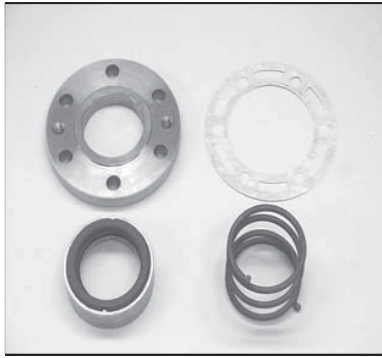

Shaft Seal, Bock FK4
Sutrak P/N 8005
Carrier P/N 24-01-75-105



Pressure Switch, HPCO
Sutrak P/N 524.146.1
Carrier P/N 20-524-146-1

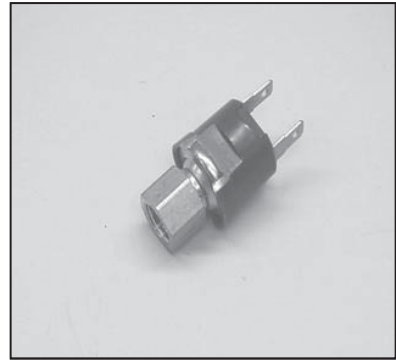

Pressure Switch, LPCO
Sutrak P/N 524.450
Carrier P/N 20-524-450



Solenoid Valve
Sutrak P/N 551.217
Carrier P/N 22-05-12-004

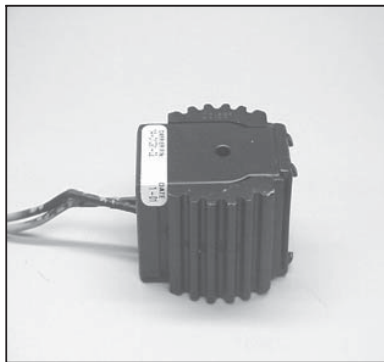

Coil, 24V
Sutrak P/N 551.212
Carrier P/N 14-01091-02

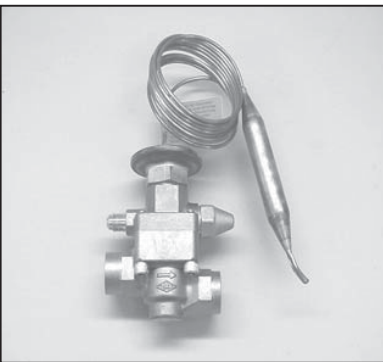

TXV, R22
Sutrak P/N 528.123
Carrier P/N 24-04-01-087

CARRIER TRANSICOLD

20-SERIES PARTS

Cross Reference



Fan Motor, 24V
Sutrak P/N 533.116S
Carrier P/N 28-02-10-015

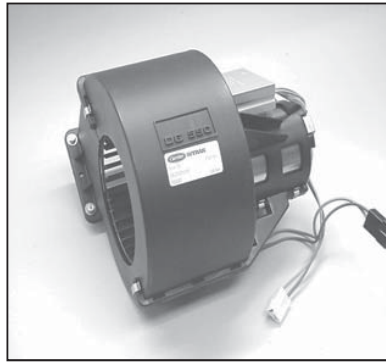

Blower Assy, w/Speed Control
Sutrak P/N 735.019BLOW
Carrier P/N 28-20-01-016

Sutrak USA



Fan Blade
Sutrak P/N 524.110S
Carrier P/N 28-23-01-024

Sutrak USA P/N	CTD P/N	DESCRIPTION
524.107	24-07-15-003	Sight glass
524.110S	28-23-01-024	Fan
524.146.1	20-524-146-1	Switch, pressure
524.450	20-524-450	Switch, pressure
528.123	24-04-01-087	TXV, R22
533.116S	28-02-10-015	Motor, 24V
551.212	14-01091-02	Coil, 24V
551.217	22-05-12-004	Solenoid valve
553.117K	26-43-01-014	Knob
554.138	20-554-138	Clutch only, for 554-142 assy. (less coil)
554.142	20-554-142	Clutch assy., includes coil (24V)
554.264	20-554-264	Coil only, for 554-142 clutch assy (24V)
735.019BLOW	28-20-01-016	Blower assy w/ speed control
8005	24-01-75-105	Shaft seal, Boch compressor

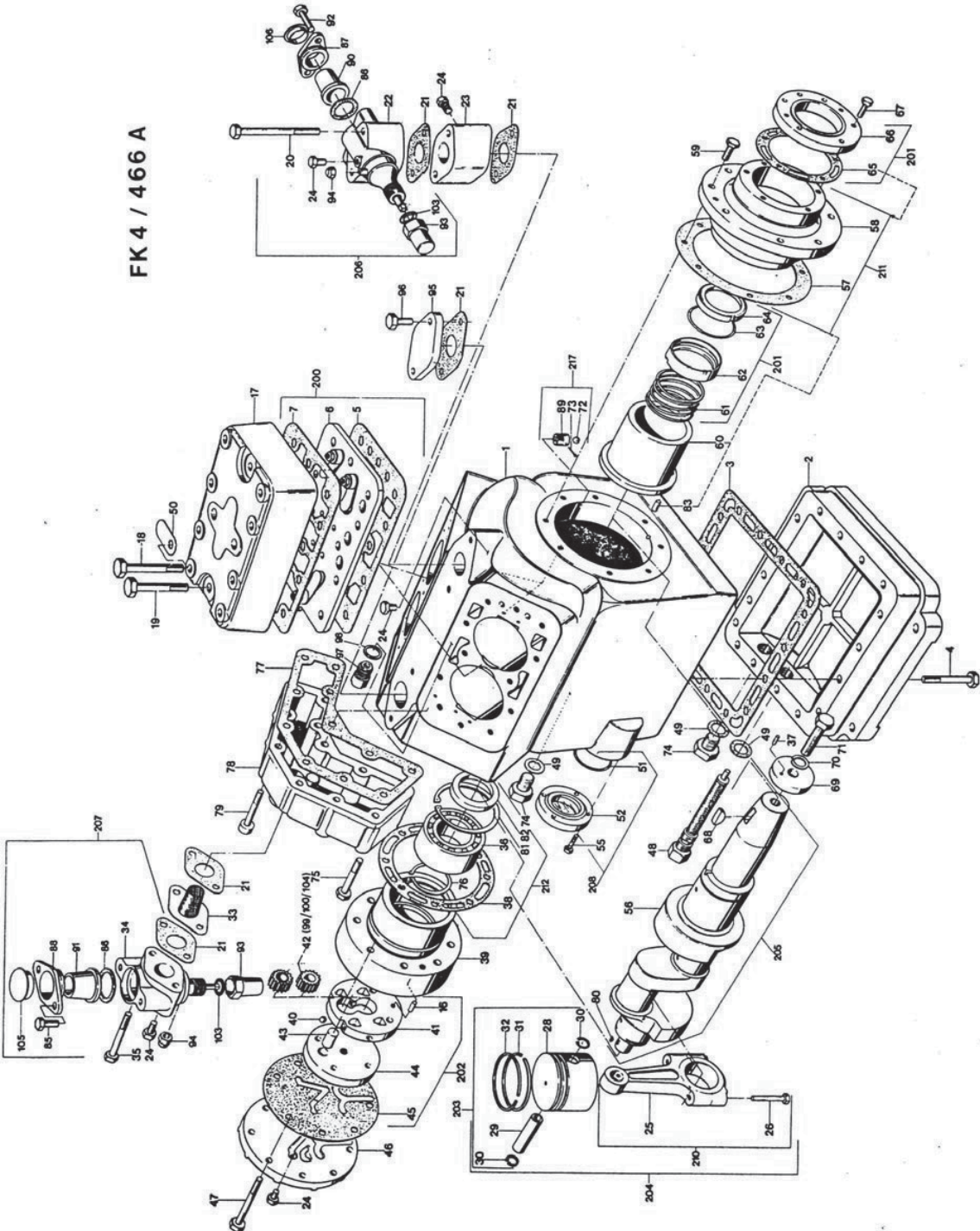

Compressors

Bock FK 4

Item#	SUTRAK	CTD P/N	DESCRIPTION
1	08328	24-01-75-157	Casing
3	05046	24-01-75-006	Base plate gasket
4	05431	24-01-75-007	Screw M 8x55
5	05028	24-01-75-008	Lower valve plate gasket
7	05010	24-01-75-010	Upper valve plate gasket
16	05688	24-01-75-011	Grooved pin 5X14
17	04089	24-01-75-012	Cylinder cover
18	05453	24-01-75-013	Screw M 10x75
19	05452	24-01-75-014	Screw M 10x65
20	05455	24-01-75-015	Screw M 10x10
21	05083	24-01-75-101	Valve flange gasket
22	07128	24-01-75-109	Shut off valve
23	04167	24-01-75-017	Flange for pressure valve
24	05514	24-01-75-018	Stopper NPT 1/8"
26	05516	24-01-75-020	Bolt for conn. Rod
29	07212	24-01-75-023	Piston pin
30	05551	24-01-75-024	Seeger circlip 15x1
31	05390	24-01-75-025	Tab ring
32	05380	24-01-75-026	Compression ring
33	04437	24-01-75-027	Filter with flange
33	03370	24-01-75-027	Filter with flange
36	07257	24-01-75-029	Ball bearing
37	05686	24-01-75-030	Adaper sleeve 4x10
38	05056	24-01-75-031	Rear bearing flange gasket
39	04132	24-01-75-032	Rear bearing flange
45	05077	24-01-75-038	Cover plate gasket
46	04164	24-01-75-039	Cover plate
47	05430	24-01-75-040	Screw, M 8x50
48	04442	24-01-75-041	Filter with magnet
49	05342	24-01-75-042	Copper disc 28x22x2
51	05153	24-01-75-044	O-ring 34,59 x 2,62
55	05402	24-01-75-048	Screw, M 6x15
57	05058	24-01-75-050	Front bearing flange gasket
58	04141	24-01-75-051	Front bearing flange
60	04359	24-01-75-053	Journal box
65	05063	24-01-75-058	Shaft seal cover gasket
67	05422	24-01-75-060	Screw M 8x25
68	05673	24-01-75-061	Woodruff ket 5x9
69	04425	24-01-75-062	Washer, 50x13x8
71	05462	24-01-75-064	Screw, M 12x40
75	06624	24-01-75-068	Screw, M 8x50

Compressors

Bock FK 4

Item#	SUTRAK	CTD P/N	DESCRIPTION
76	05570	24-01-75-069	Circlip 35x1,5
77	05071	24-01-75-070	Gasket, suction side
78	04162	24-01-75-071	Cover, suctions side
79	05484	24-01-75-117	Screw, M 8x40
80	05670	24-01-75-073	Woodruff key 3x3,7
81	05557	24-01-75-074	Circlip 72x2,5
82	05350	24-01-75-075	Shim, ballbearing
83	05688	24-01-75-076	Grooved pin
85	05489	24-01-74-566	Bolt, M 10x35
86	05067	24-01-75-083	Ring gasket
87	04328	24-01-75-084	Oval flange discharge
88	04329	24-01-75-085	Oval flange suction
90	04367	24-01-75-086	Soldering flange NW 25
91	05313	24-01-75-087	Soldering flange NW 32
92	05447	24-01-75-089	Bolt M 10x35
93	05784	24-01-74-567	Cap nut, M 22x1,5
94	05789	24-01-74-560	Cap nut, UNF 7/16
96	05446	24-01-75-078	Bolt, M 10x30
97	07134	24-01-75-153	Safety valve
97	07940	24-01-75-153	Safety valve
98	05791	24-01-75-120	Ring gasket
103	05808	24-01-75-121	Ring gasket
200	08198	24-01-75-090	Valve plate kit. Incl. 5,6,7,8,9,10,11,12,13,14,15,16
201	08005	24-01-75-105	Shaft seal assy kit. Incl 61,62,63,64,65,66
202	08044	24-01-75-091	Oil pump assy kit. Incl 16,40,41,42,43,44,45
203	08034	24-01-75-096	Piston assy kit. Incl. 28,29,30,31,32
204	08022	24-01-75-092	Piston conn. Rod. Incl. 25,26,28,29,30,31,32
205	08055	24-01-75-049	Crankshaft assy kit. Incl. 56,68,80
206	08084	24-01-75-094	Valve(disch)Incl.21,22,24,86,87,90,92,93,94,103,106
207	08082	24-01-75-095	Valve (suct) Incl. 21,24,34,85,86,88,91,94,96,103,105
208	08130	24-01-75-099	Sight glass assy kit. Incl. 51,52
209	08071	24-01-75-093	Gasket set. Incl. 3,5,7,21,38,45,49,51,57,65,77,86,98
210	08304	24-01-75-125	Conn. Rod kit Incl. 25,26
211	08158	24-01-75-126	Front bearing assy kit. Incl. 578,58,60,65,83
212	08104	24-01-75-130	Rear bearing assy kit. Incl. 36,38,76,81,82
217	08111	24-01-75-106	Compensation jet kit. Inc. 72,73,89

Cross Reference



TXV, 1.5 Ton, R134A
Transair P/N 2160074
Carrier P/N AC101-107



TXV, 2 Ton, R134A
Transair P/N 210019
Carrier P/N 20-210019



TXV, 3 Ton, 3/8 x 1/2 SAE
Transair P/N 210031
Carrier P/N 20-210031



Resistor, 1 Ohm, 35 Watt
Transair P/N 111022

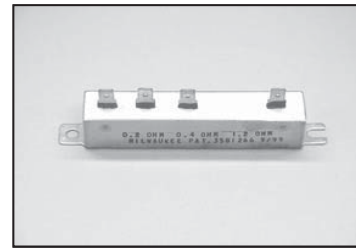

Resistor, 1.8 Ohm, 4 Tap
Transair P/N 111060
Carrier P/N AC201-611

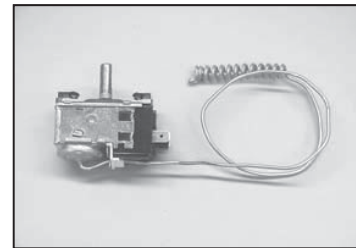

Thermostat, Rotary
Transair P/N 111059
Carrier P/N 20-111059



Thermostat, Rotary
Transair P/N 111051
Carrier P/N AC201-500

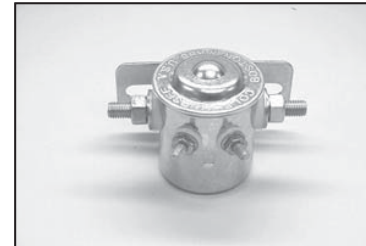

Solenoid, 12 V
Transair P/N 112001
Carrier P/N AC201-800



Circuit Breaker
Transair P/N 110001
Carrier P/N AC201-112



Switch, HPCO
Transair P/N 111001
Carrier P/N AC201-400



Switch, LPCO
Transair P/N 111025
Carrier P/N AC201-404

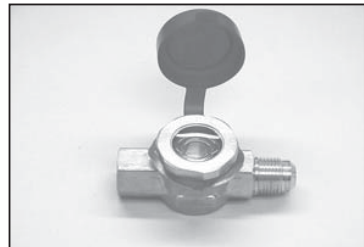

Sight Glass
Transair P/N 211004
Carrier P/N AC101-200

Trans/Air Parts

Cross Reference

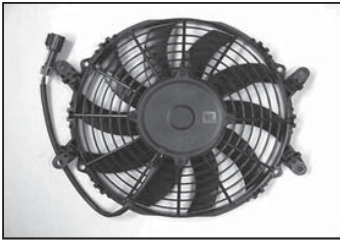

Fan, 10" w/ Mounting Clips

Transair P/N 2160088

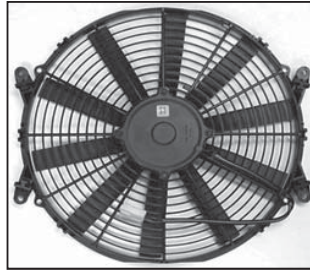

Fan, 14" w/ Mounting Clips

Transair P/N 2160089
Carrier P/N 20-2160089

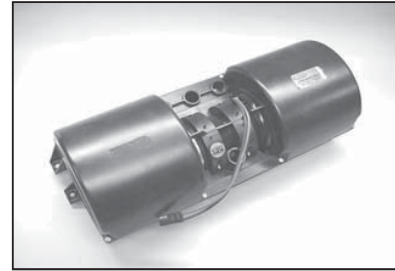

Blower Assy, 12 V

Transair P/N 412025
Carrier P/N AC401-209A

Trans/Air Parts

Cross Reference

Trans/Air Parts

Trans/Air P/N	CTD P/N	DESCRIPTION
110001	AC201-112	Resetable C.B. 40A
110004	AC201-119	Circuit Breaker 40A
111001	AC201-400	High Pressure Switch
111022	20-111022	Resistor
111025	AC201-404	Low Pressure Switch
111051	AC201-500	Thermostat
111059	20-111059	Thermostat
111060	AC201-611	Resistor, 1.8 Ohm
112001	AC201-800	Solenoid
112007	AC201-806	Relay, 40 Amp, 12V
113006	AC201-305	Switch fan speed
113033	AC202-300	Knob (Fan)
113032	AC202-303	Knob (Snowflake)
210019	20-210019	TXV
210031	20-210031	TXV
211004	AC101-200	Sight Glass
211007	AC101-200	Sight Glass
202021	14-00288-00	Filter Drier with sight glass
212010	14-00329-11	Filter Drier
212029	AC101-312	Receiver/drier
2160074	14-00301-03	TXV
2160088	20-2160088	Fan Assembly, with brackets. Replaces 2160080
2160089	20-2160089	Fan assembly, 14", 12V
311006	AC301-100	Hose # 6
311007	AC301-101F50	Hose # 8
311008	AC301-102	Hose # 10
311009	AC301-103	Hose # 12
312010	AC301-240	Hose, valve Kazoo, 1-1/4 x 3"
313018	AC301-448	Fitting "Y" 12 x 12 x 12

CARRIER TRANSICOLD

20-SERIES PARTS

Cross Reference

Trans/Air Parts

Transair P/N	CTD P/N	DESCRIPTION
313176	AC302-432	Fitting 90 5/8 x 12
313177	AC301-419	Fitting 90 1/2 x 10
313178	AC301-473	Fitting 90 5/8 x 10
313179	AC301-447	Fitting STR 1/2 x 10
313181	AC302-465	Fitting 90 3/4 x 12
313183	AC301-429	Fitting TEE 12 x 12 x 12
313184	AC301-432	Fitting TEE 8 x 8 x 8
313185	AC301-418	Fitting 90 1/2 x 8
313186	AC301-497	Fitting STR 3/4 x 12
313189	AC301-435	Fitting STR 5/8 x 10
313191	AC301-465	Fitting STR 3/8 x 8
313193	AC301-457	Fitting Tube "O" 1/2 M.I.O.
313194	AC301-458	Fitting Tube "O" 5/8 M.I.O.
313195	AC302-436	Fitting SPL 10 x 10 (Low Side)
313197	AC302-437	Fitting SPL 10 x 10 (High Side)
313199	AC301-483	Fitting STR 5/8 x 10
313204	AC302-443	Fitting TEE 12 M.SL. x 12 F.SL. x 12
313208	AC301-482	Fitting STR 1/2 x 8
313209	AC302-444	Fitting 90 8 M. SL. x 10
313210	AC302-403	Fitting 90 8 M. SL. x 8
313212	AC301-433	Fitting 90 3/8 x 8
313213	AC302-429	Fitting TEE 27 mm M.I.O. x 27 mm F.O x 12
313214	AC302-452	Fitting TEE 22 mm M.I.O. x 22 mm F.O x 12
313215	AC302-457	Fitting TEE 22 mm M.I.O. x 22 mm F.O x 10
313216	AC301-423	Fitting STR 3/8 x 6
313217	AC301-421	Fitting STR 5/8 x 10
313219	AC301-462	Fitting 90 3/8 x 6
313221	AC302-405	Fitting TEE 10 M.SL. 10 F.SL. x 12
313224	AC301-409	Fitting TEE 12 x 12 x 10
313225	AC301-408	Fitting TEE 8 x 8 x 6
313230	AC302-433	Fitting TEE 20 mm M.I.O. x 20 mm F.O x 8
313231	AC301-464	Fitting STR 3/8 x 8
313232	AC301-403	Fitting 90 3/8 x 8
313241	AC301-492	Fitting STR 8 F. SL. x 8
313252	AC301-412	Fitting - Ref splicer #8
313253	AC301-413	Fitting - Ref splicer
313254	AC301-414	Fitting - Ref splicer
314016	AC302-438	Adapter 7/16 FFL x R134a Access (High Side)
314017	AC302-439	Adapter 7/16 FFL x R134a Access (Low Side)
412012	AC401-301	Louver 3" Diameter
412014	AC401-314	Louver
412025	AC401-209A	Blower Assembly
501005	AC010-008	Back Hose Cover
501-003-W	AC011-032-1	Cover hose, transition, white

CARRIER TRANSICOLD

20-SERIES PARTS

Cross Reference

Trans/Air Parts

Transair P/N	CTD P/N	DESCRIPTION
512129	AC502-210	Compressor, TM-16
518002	AC801-201	O-Ring 3/8
518003	AC801-202	O-Ring 1/2
518004	AC801-203	O-Ring 5/8
518006	AC801-217	O-Ring 3/4
611028	AC701-213	Ferrule # 8
611029	AC701-214	Ferrule # 10
611030	AC701-215	Ferrule # 12
611031	AC701-216	Ferrule # 6
701127	AC202-301	Plate 3 Switch
711003	AC601-505	Eccentric 1.25 Throw x 1.125 High
711008	AC601-524	Shoulder Bolt Single Pulley
711018	AC6601-510	Eccentric 1-7/8 "
714053	AC601-508	Brushing 7/16 Bore
816021	AC101-708	Tool, Hosecutter
816035	07-00295-00	Leak Detector

Cross Reference

A.C.T. Parts

A.C.T. P/N	CTD P/N	DESCRIPTION
211007	AC101-200	INDICATOR,1/2MFL x 1/2FFL SAE
313252	AC301-412	FTG, REF-SPLICER #8
313253	AC301-413	FTG.REF.SPLICER
313254	AC301-414	FITTING,REF.SPLICER
200-009	AC401-300	GRILLE,ROUND 2" BLCK
220-008-W	AC011-049-1	HOSE COVER,60 DEG ELBOW(WHITE)
220-009-W	AC011-032-1	COVER HOSE, TRANSITION(WHITE)
400-009	AC502-220	COMPR,TM16,2A GRV,VOR,12V,134A
400-011	AC502-210	COMPRESSOR, TM-16
400-013	18-00074-36	COMPRESSOR, TM16 BOLT PAD 12V
400-015	AC502-210	COMPRESSOR, TM-17
400-018	18-00074-35	COMPRESSOR,TM-16,8GR POLY V
400-024	18-00073-00	MOTOR, 5HP GP 208-230/460-3-6
400-036	17-31248-00	COMPR, TM31,12VDC,8-GRV POLY V
410-002	17-31244-00	COMPR, TM31,12VDC, 2A GROOVE
500-015	AC201-600	DIODE,IN-LINE 6A
501-003-W	AC011-032-1	COVER HOSE, TRANSITION(WHITE)
BLW-200	AC401-209A	BLOWER ASSY, 12VDC, GEN II
BLW-200-41	AC401-209A	BLOWER ASSY, 12VDC, GEN II
BLW-202	AC401-200A	BLOWER,12V,GEN I,(W/6 CLIPS)
BLW-204	AC401-203	BLOWER ASSY EM14 12V
BRK-020	AC201-105	BREAKER, CIRCUIT 20A MANUAL
BRK-030	AC201-106	BREAKER, CIRCUIT 30A MANUAL
BRK-040	AC201-112	BREAKER, CIRCUIT 40A MANUAL
BRK-050	AC201-107	CIR BREAKER, 50A MAN
BRK-120	10-00171-14	BREAKER, CIRCUIT 20A TYPE 2
DRI-100	AC101-312	DRIER,FILTER, WITH O-RINGS
DRI-101	14-00326-11	DRIER, FILTER
DRI-103	AC101-304	RECEIVER/DRIER #8
DSI-300	14-00288-00	DRIER, FILTER (W/ SIGHTGLASS)
EXP-001	20-210019	TXV, R134A
EXP-012	AC101-100	THERM EXP VALVE R-12
EXP-134	14-00301-03	VALVE, EXPANSION, TXV, 2 TON
EXP-134	14-00301-03	VALVE, EXPANSION, TXV, 2 TON
FTG-101	AC301-404	FITTING, REFG, 9
FTG-102	AC301-419	FITTING,REF.-90 1/2"
FTG-103	AC302-432	FITTING,REF.-90 5/8"
FTG-105	AC302-453	FTG,ADAPTOR W. ACC
FTG-106	AC302-454	FTG,ADAPTOR W. ACC
FTG-107	AC302-437	FITTING,SPLICER 1/2
FTG-108	AC302-436	FITTING,SPLICER 5/8
FTG-109	AC301-412	FTG, REF-SPLICER #9
FTG-110	AC301-413	FTG.REF.SPLICER
FTG-111	AC301-414	FITTING,REF.SPLICER
FTG-112	AC301-432	FTG,REF,TEE 8X8X8

CARRIER TRANSICOLD

20-SERIES PARTS

Cross Reference

A.C.T. Parts

Transair P/N	CTD P/N	DESCRIPTION
FTG-113	AC301-429	FTG,REF,TEE12X12X12
FTG-114	AC302-494	FITTING, 1/2-10
FTG-115	AC302-495	FITTING, 5/8-12
FTG-116	AC301-441	FTG,REF,90-SU 1/2
FTG-119	AC301-435	FTG.REF STRGHT 5/8"
FTG-120	AC303-415	FITTING,SUCTION LINE
FTG-121	AC301-447	FTG,REF-STRGT 1/2"
FTG-122	AC301-433	FTG,REF 90-3/8"
FTG-123	AC301-464	FTG.STR 3/8"
FTG-124	AC301-418	FTG,REF.90 1/2"
FTG-125	AC301-482	FTG.REF.STR 1/2"
FTG-126	AC302-429	FTG,TEE-27MM
FTG-127	AC302-430	FTG,90W/ADD-20MM
FTG-129	AC302-466	FTG,TUBE-O
FTG-133	AC301-473	FTG,REF 90 5/8"
FTG-134	AC302-465	FTG,90-3/4 X#12
FTG-142	AC301-451	FTG.REF.Y-SPLICER
FTG-143	AC301-448	FTG.REF.Y-SPLCR
FTG-146	AC301-410	FTG.REF.STEPUP SPLCR
FTG-148	AC302-400	FITTING,TEE (1/2 x 1/2 x #6)
FTG-177	AC302-464	FITTING,STRGT 27 MM
FTG-181	AC301-462	FTG,REF.90 3/8"F
FTG-184	AC301-444	FTG,REF-TEE#6X#6X#6
FTG-193	40-62019-01	FITTING,TEE,O-RING,#8Mx#8Fx#8M
FTG-266	AC301-455	FTG.REF. SPLCR STEP
FTR-001	AC801-405	FILTER, METAL, EM-1/2
FTR-002	AC101-306	FILTER,SUCT LINE
FTR-011	38-00573-07	FILTER, AIR, EM-3, GEN 4
HPS-501	AC201-400	SWITCH, PRESSURE, HIGH
HPS-504-P	AC201-400	SWITCH, PRESSURE, HIGH
HPS-505-P	AC201-404	SWITCH PRESSURE LOW
HSC-002	AC701-205	CLAMP, DRAIN HOSE
HSE-008	AC301-101F50	HOSE,REFRIGERANT #8 (50 FT LG)
HSE-010	AC301-102	HOSE,REFRIGERANT #10
HSE-012	AC301-103	HOSE,REFRIGERANT #12
KAZ-002	AC301-240	HOSE, VALVE-KAZOO, 1-1/4 x 3"
LPS-101-P	AC201-400	SWITCH, PRESSURE, HIGH
LPS-101-P	AC201-404	SWITCH PRESSURE LOW
MTR-100	AC501-102A	MOTOR, 12 V COND
MTR-104	79-01957-01	FAN ASSY, COND, VECTOR 6500
MTR-140-V	54-00618-01	MOTOR/FAN ASY,12VDC,11",W/FUSE
NCV301	AC202-306	NUT,HEX(FAN SPD SW)
NOB-001	AC202-300	KNOB, FAN, RUBBER, BLACK
NOB-001	AC202-300	KNOB, FAN, RUBBER, BLACK
NOB-002	AC202-303	KNOB, SNOWFLAKE

CARRIER TRANSICOLD

20-SERIES PARTS

Cross Reference

A.C.T. Parts

Transair P/N	CTD P/N	DESCRIPTION
NOB-002	AC202-303	KNOB, SNOWFLAKE
ORG-012	AC801-202	O-RING, 1/2"
ORG-034	AC801-217	O-RING, GREEN, .676"ID/.070"THK
ORG-038	AC801-201	O-RING, 3/8"
ORG-058	AC801-203	O-RING, 5/8"
ORG-111	AC801-218	O-RING, TUBE-O SQRE
PDE-001	AC301-908	FTG, PLAS DRN ELL 5/8
PDT-001	AC301-907	FITTING, TEE, DRAIN, PLASTIC 5/8"
PEP-101	AC101-200	INDICATOR, 1/2MFL x 1/2FFL SAE
PLT-100	AC202-301	SWITCHPLATE, CONTROL PANEL
PLT-150	AC202-302	SWITCHPLATE, ROUND
REL-500	AC201-806	RELAY 40AMP/12 VOLT
REL-510	10-00328-00	RELAY (70 AMP)
RES-400	76-62019-00	RESISTOR, KIT
RES-400	AC201-611	RESISTOR 1.8 OHM/EVA
SKT-300	AC201-902	HARNESS, FAN SPEED SW. (GEN 4)
SWC-300	AC201-305	SWITCH FAN SPEED
SWC-300	AC201-305	SWITCH FAN SPEED
SWC-301	AC201-500	SWITCH, THERMOSTAT, DRIVERS

Cross Reference

ACC Parts

A.C.C. P/N	CTD P/N	DESCRIPTION
02220606A	AC301-240	HOSE, VALVE-KAZOO, 1-1/4 x 3"
04200501A	AC201-500	SWITCH,THERMOSTAT, DRIVERS
04205400A	AC202-300	KNOB, FAN, RUBBER, BLACK
04205450A	AC202-303	KNOB, SNOWFLAKE
08801800A	AC801-203	O-RING,5/8"
08802000A	AC801-217	O-RING,GREEN, .676"ID/.070"THK
08813803A	AC201-119	BREAKER, CIRCUIT 40 AMP
08813921A	AC201-404	SWITCH PRESSURE LOW
08813961A	AC201-400	SWITCH, PRESSURE, HIGH
26060036B	AC401-209A	BLOWER ASSY, 12VDC, GEN II

Hoses & Fittings

Carrier
TRANSICOLD
20 SERIES
PERFORMANCE PARTS

Build Carrier Quality into your Bus A/C unit with these new products.

The Hoses & Fittings section is designed to provide you with a complete guide including photos and specifications on all our hoses and fittings. We offer a full line of hoses and fittings to meet all your competitive needs.





EAT•N Aeroquip

A/C & Refrigeration Hose & Fittings



**Carrier Specific -
20 Series Parts**
Form 62-11246 Rev A

E-Z Clip System™

Tool Case

Part # FF12139

NOTE:

The E-Z Clip System has been designed to work exclusively with Aeroquip GH134 Hose.



KIT CONTENTS DESCRIPTION	QTY/PER KIT
Clips #6/#8/#12	20 each size
Cages #6/#8/#10/#12	10 each size
Assy. Tool	1
Hose Cutter	1
Replacement Blade	1

E-Z Clip System™

GH134 Multi-Refrigerant Hose

SAE J2064
Type E Class 1

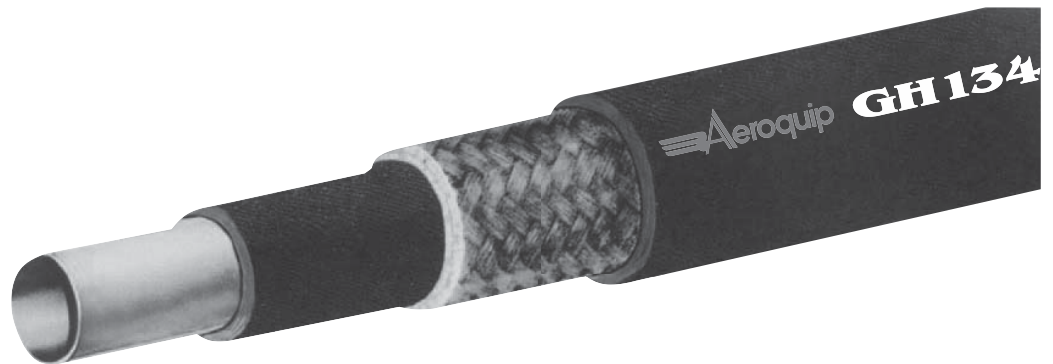

50' LENGTH PART#	300' LENGTH PART#	SIZE	HOSE I.D.	HOSE O.D.	MAXIMUM OPERATING PRESSURE	E-Z CLIP MINIMUM BURST PRESSURE	MINIMUM BEND RADIUS	WEIGHT PER FOOT
			MM/INCHES	MM/INCHES	BAR/PSI	BAR/PSI	MM/INCHES	POUNDS
20-61-617	20-67-1708	#6	7.9/.31	14.7/.58	35/500	140/2000	50/2.00	.09
20-61-627	20-67-1709	#8	10.3/.41	17.8/.70	35/500	140/2000	63/2.50	.12
20-61-637	20-67-1710	#10	12.7/.50	19.8/.78	35/500	140/2000	76.2/3.00	.15
20-61-643	20-67-1711	#12	15.9/.63	24.9/.98	35/500	140/2000	101.6/4.00	.18

Application: Transportation, refrigeration and air conditioning systems.

Operating Temperature Range: -22°F to +257°F (-30°C to +125°C).

R404a Effusion: .2 lbs./ft²/yr. at 140°F (.8 kg./m²/yr. at 60°C)

HFC 134a Effusion: .50 lbs./ft²/yr. at 176°F (2.42 kg./m²/yr. at 80°C)

R22 Effusion: 27.7 lbs./ft²/yr. at 158°F (135 kg./m²/yr. at 70°C)

R407C Effusion: 20 kg./m²/yr. at 80°C

Moisture Ingression: .08 gm./in²/yr. (.013/cm²/yr)

Features

- Internal polyamide veneer tube
- Synthetic-rubber backing layer
- Stabilized, synthetic braided reinforcement
- Chlorobutyl rubber cover
- E-Z Clip fittings

Benefits

- Excellent effusion resistance
- Maximum resistance to moisture ingress
- Extended service performance
- Superior flexibility
- Assured coupling integrity, exceeds SAE J2064 performance

E-Z Clip System™

Fittings

FJ5984

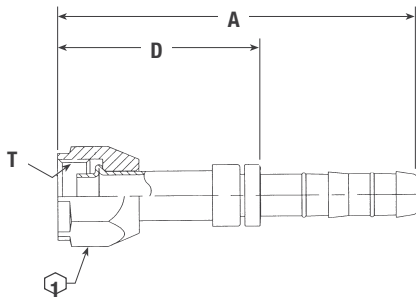

Straight – Female O-ring (short pilot)

PART NUMBER	TH'D "T"	HOSE SIZE	A REF	D REF	F REF	H REF	① REF
FJ5984-606S	5/8-18	6	3.14	1.62	—	—	0.75
20-55-9450	5/8-18	8	3.16	1.62	—	—	0.75
20-55-9526	3/4-16	8	3.56	2.02	—	—	0.88
20-55-9527	3/4-16	10	3.57	2.02	—	—	0.88
20-55-9528	7/8-14	10	3.63	2.08	—	—	1.06
20-55-9451	7/8-14	12	3.66	2.08	—	—	1.06
FJ5984-1212S	1-1/16-14	12	4.25	2.67	—	—	1.25

FJ3055

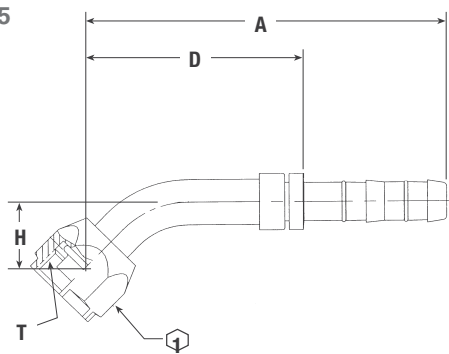

45° Elbow Female O-ring (short pilot)

PART NUMBER	TH'D "T"	HOSE SIZE	A REF	D REF	F REF	H REF	① REF
FJ3055-03-0808S	3/4-16	8	3.94	2.40	—	0.73	0.88
FJ3055-04-0810S	3/4-16	10	3.95	2.40	—	0.73	0.88
FJ3055-05-1010S	7/8-14	10	4.37	2.81	—	1.19	1.06
FJ3055-06-1012S	7/8-14	12	4.46	2.88	—	1.25	1.06
FJ3055-07-1212S	1-1/16-14	12	5.33	3.75	—	1.47	1.25

FJ5985

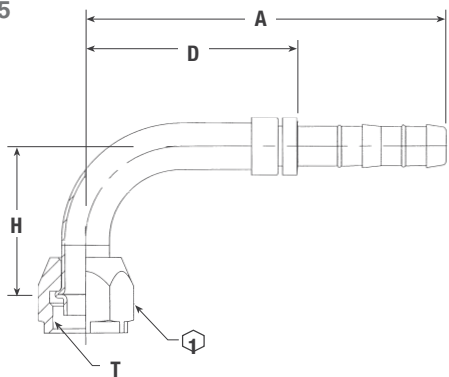

90° Elbow – Female O-ring (short pilot)

PART NUMBER	TH'D "T"	HOSE SIZE	A REF	D REF	F REF	H REF	① REF
20-55-9403	5/8-18	6	3.32	1.79	—	1.38	0.75
20-55-9446	5/8-18	8	3.33	1.79	—	1.38	0.75
20-55-9404	3/4-16	8	3.77	2.23	—	1.62	0.88
20-55-9447	3/4-16	10	3.78	2.23	—	1.62	0.88
20-55-9405	7/8-14	10	4.22	2.67	—	1.89	1.06
20-55-9448	7/8-14	12	4.24	2.67	—	1.89	1.06
20-55-9406	1-1/16-14	12	4.74	3.16	—	2.56	1.25

FJ3053

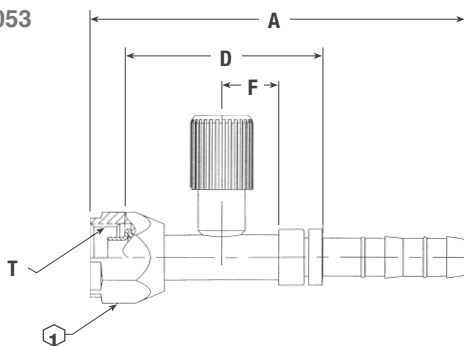

Straight – Female O-ring (short pilot) with R134a High Side Port

PART NUMBER	TH'D "T"	HOSE SIZE	A REF	D REF	F REF	H REF	① REF
FJ3053-0808S	3/4-16	8	4.09	2.16	0.63	—	0.88
FJ3053-0810S	3/4-16	10	4.09	2.16	0.63	—	0.88

E-Z Clip System™

Fittings

FJ3054

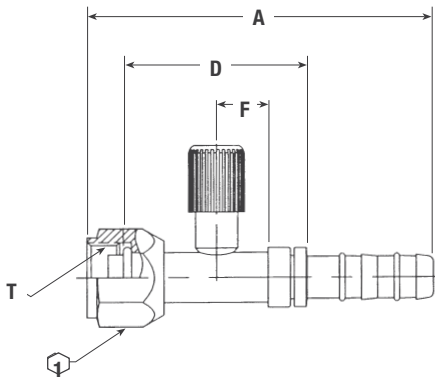

Straight – Female O-ring (short pilot) with R134a Low Side Port

PART NUMBER	TH'D "T"	HOSE SIZE	A REF	D REF	F REF	H REF	① REF
20-55-9531	7/8-14	10	4.24	2.25	0.63	—	1.06

FJ3363

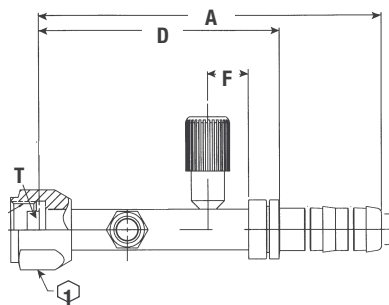

Straight – Female O-ring (short pilot), with R134a High side port and female switch connection, (1/8-27 thread)

PART NUMBER	TH'D "T"	HOSE SIZE	A REF	D REF	F REF	H REF	① REF
20-55-9535	3/4-16	8	5.16	3.62	.63	—	.88
20-55-9536	3/4-16	10	5.54	3.62	.63	—	.88
20-55-9537	7/8-14	12	5.30	3.72	.63	—	1.06

FJ3012

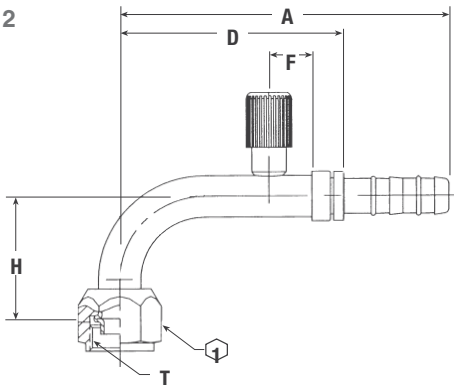

90° Female O-ring (short pilot) with R134a Low Side Port

PART NUMBER	TH'D "T"	HOSE SIZE	A REF	D REF	F REF	H REF	① REF
FJ3012-01-1012S	7/8-14	10	4.83	3.25	0.63	1.89	1.06
FJ3012-03-1212S	1-1/16-14	12	5.10	3.52	0.63	2.56	1.25

FJ3013

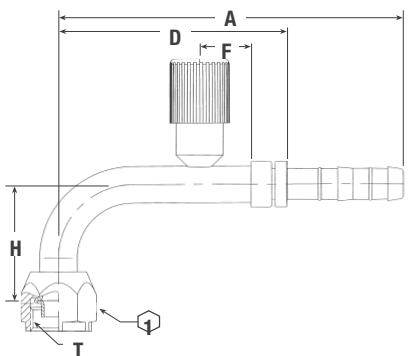

90° Female O-ring (short pilot) with R134a High Side Port

PART NUMBER	TH'D "T"	HOSE SIZE	A REF	D REF	F REF	H REF	① REF
FJ3013-03-0808S	3/4-16	8	4.61	3.07	0.69	1.62	0.88
FJ3013-01-0810S	3/4-16	10	4.53	2.98	0.69	1.62	0.88

E-Z Clip System™

Fittings

FJ3289

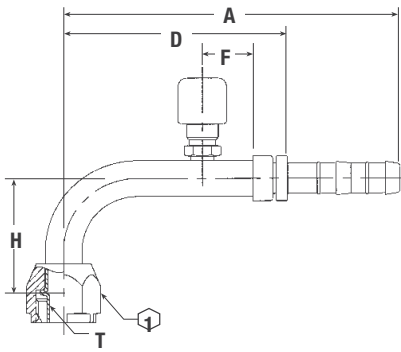

90° Female O-ring (long pilot) with Switch Port (7/16-20 thd)

PART NUMBER	TH'D "T"	HOSE SIZE	A REF	D REF	F REF	H REF	① REF
FJ3289-02-1010S	7/8-14	10	4.80	2.77	0.63	1.93	1.06

FJ3052

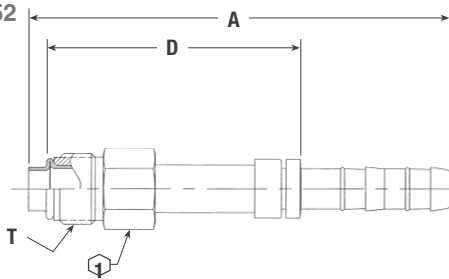

Straight Male O-ring (short pilot)

PART NUMBER	TH'D "T"	HOSE SIZE	A REF	D REF	F REF	H REF	① REF
FJ3052-0606S	5/8-18	6	3.41	1.70	—	—	0.62
FJ3052-0608S	5/8-18	8	3.43	1.70	—	—	0.62
FJ3052-1010S	7/8-18	10	3.66	1.92	—	—	0.88
FJ3052-1012S	7/8-18	12	3.68	1.92	—	—	0.88

FJ3116

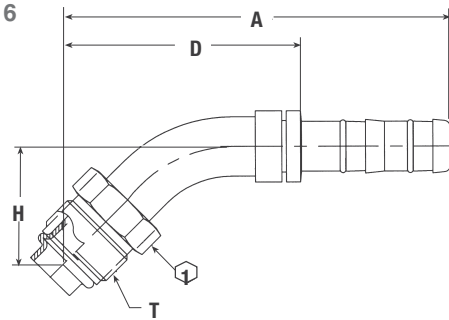

45° Male O-ring (short pilot)

PART NUMBER	TH'D "T"	HOSE SIZE	A REF	D REF	F REF	H REF	① REF
FJ3116-04-0608S	5/8-18	8	4.01	2.47	—	0.94	0.62

FJ3019

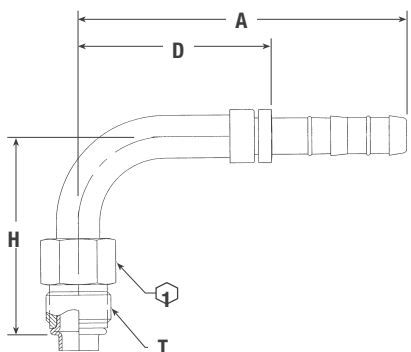

90° Male O-ring (short pilot)

PART NUMBER	TH'D "T"	HOSE SIZE	A REF	D REF	F REF	H REF	① REF
FJ3019-03-0606S	5/8-18	6	3.33	1.80	—	1.77	0.62
FJ3019-02-0608S	5/8-18	8	3.34	1.80	—	1.77	0.62
FJ3019-07-1010S	7/8-18	10	4.22	2.67	—	2.453	0.88
FJ3019-01-1012S	7/8-18	12	4.24	2.67	—	2.45	0.88

E-Z Clip System™

Fittings

FJ3026

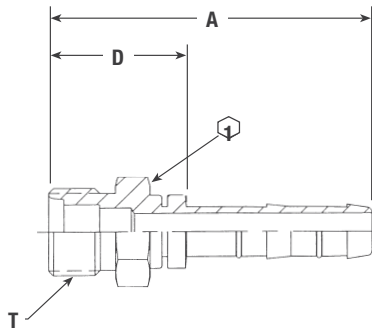

Male MIO (male insert O-ring) Straights

PART NUMBER	TH'D "T"	HOSE SIZE	A REF	D REF	F REF	H REF	① REF
FJ3026-1010S	7/8-14	10	2.90	1.35	—	—	0.940

FJ3057

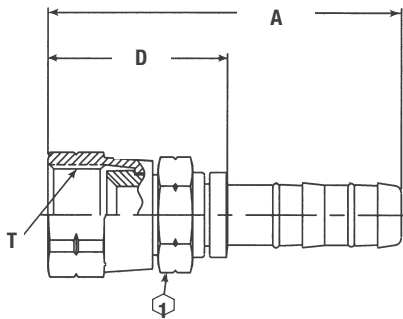

Female SAE 45° Flares

PART NUMBER	TH'D "T"	HOSE SIZE	A REF	D REF	F REF	H REF	① REF
FJ3057-03-0808S	3/4-16	8	2.96	1.42	—	—	0.69

FJ3149

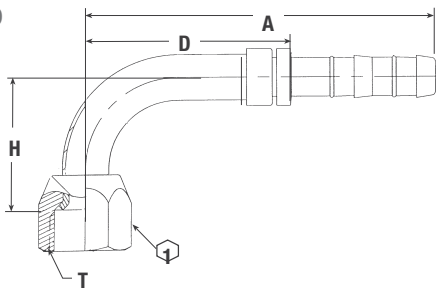

90° Female SAE 45° and Universal Flares

PART NUMBER	TH'D "T"	HOSE SIZE	A REF	D REF	F REF	H REF	① REF
FJ3149-03-0808S*	3/4-16	8	2.74	1.20	—	1.09	0.88
FJ3149-04-1010S*	7/8-14	10	3.09	1.54	—	1.19	1.00
FJ3149-06-1212S†	1-1/16-14	12	3.68	2.11	—	1.80	1.25

†Double notch in nut for universal type identification

*Universal Flare

GA23911

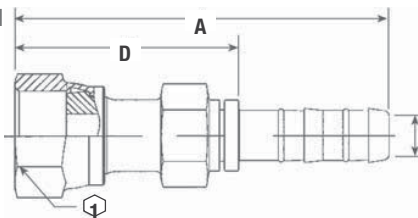

Straight – ORS Female Swivel Metric Hex Nut^Δ

PART NUMBER REF	TH'D	HOSE "T"	A SIZE	D REF	F REF	H REF	① REF
20-55-9685	1-1/16-16	6	2.95	1.43	—	—	22mm
20-55-9521	1-3/16-16	8	3.17	1.62	—	—	24mm
20-55-9522	1-1/4	10	3.33	1.78	—	—	30mm
20-55-9596	1-3/16-12	12	3.38	1.80	—	—	36mm

Δ Metric Hex

E-Z Clip System™

Fittings

FJ3161
GA23912

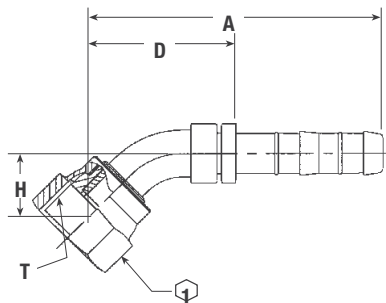

45° ORS Female Swivel

PART NUMBER REF	TH'D	HOSE "T"	A SIZE	D REF	F REF	H REF	① REF
FJ3161-01-0606S	11/16-16	6	2.65	1.12	—	0.44	0.81
20-55-9524*	13/16-16	8	3.02	1.47	—	0.59	29mm
20-55-9525*	1-14	10	3.22	1.67	—	0.70	30mm

Δ*Metric Hex

FJ5994

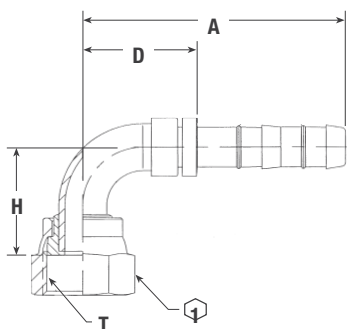

90° ORS Female Swivel

PART NUMBER REF	TH'D	HOSE "T"	A SIZE	D REF	F REF	H REF	① REF
20-55-9407	1-1/16-16	6	2.50	0.98	—	0.91	0.81
20-55-9408	13/16-16	8	2.74	1.20	—	1.15	0.94
20-55-9409	1-14	10	3.09	1.53	—	1.27	1.12
20-55-9520	1-3/16-12	12	3.36	1.78	—	1.90	1.38
20-55-9410	1-14	12	3.11	1.53	—	1.78	1.13

FJ3045

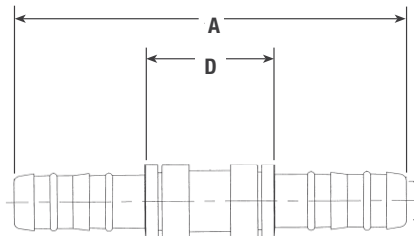

Straight Splicer

PART NUMBER REF	TH'D	HOSE SIZE	A REF	D REF	F REF	H REF	① REF
FJ3045-0808S	—	8	4.76	1.68	—	—	—
FJ3045-1010S	—	10	5.68	2.58	—	—	—
FJ3045-1212S	—	12	4.72	1.57	—	—	—

FJ3058

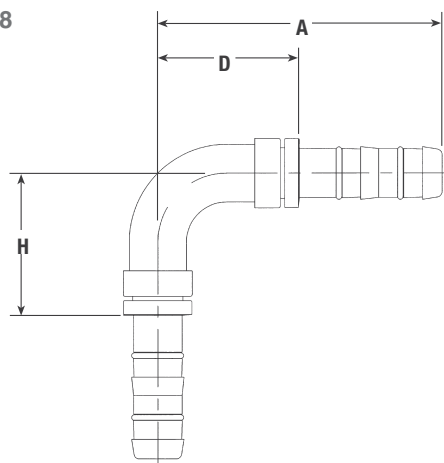

90° Splicer

PART NUMBER REF	TH'D	HOSE "T"	A SIZE	D REF	F REF	H REF	① REF
FJ3058-02-0808S	—	8	2.98	1.43	—	2.98	—
FJ3058-03-1010S	—	10	3.08	1.53	—	3.08	—
FJ3058-04-1212S	—	12	3.68	2.11	—	3.68	—

E-Z Clip System™

Fittings

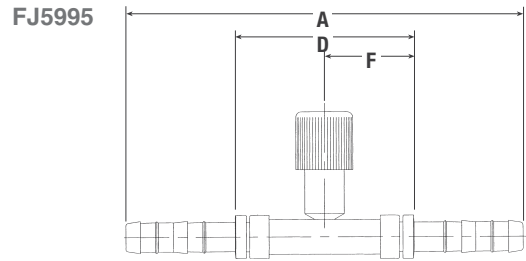

Splicer with High Side R134a Port

PART NUMBER	TH'D "T"	HOSE SIZE	A REF	D REF	F REF	H REF	① REF
20-55-9600	—	8	5.61	2.52	1.26	—	—
FJ5995-1010S	—	10	5.62	2.52	1.26	—	—

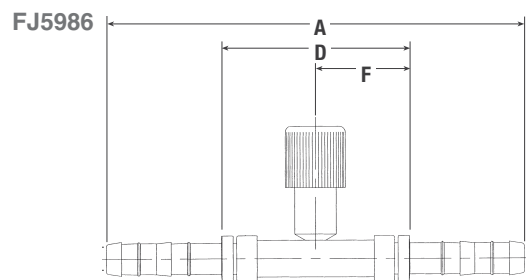

Splicer with R134a Low Side Port

PART NUMBER	TH'D "T"	HOSE SIZE	A REF	D REF	F REF	H REF	① REF
20-55-9601	—	10	5.54	2.44	1.22	—	—
20-55-9602	—	12	5.60	2.44	1.22	—	—

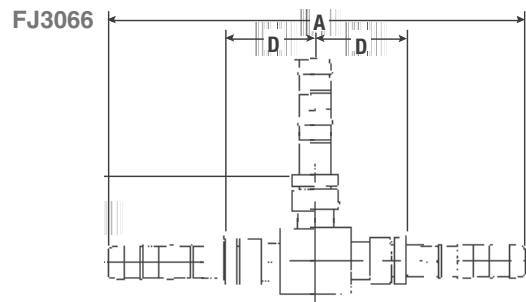

"T" Splicer – 3 Hose Connector

PART NUMBER	TH'D "T"	HOSE SIZE	A REF	D REF	F REF	H REF	① REF
FJ3066-0808S	—	8	5.48	2.40	—	—	—
FJ3066-1010S	—	10	5.62	2.52	—	—	—
FJ3066-1212S	—	12	5.67	2.52	—	—	—

E-Z Clip System™

Cages and Clips

Cages / Fitting to Hose Attachment

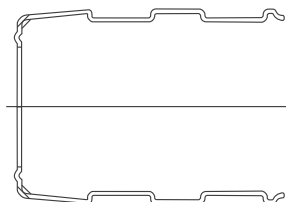

PART NUMBER	CAGE SIZE	HOSE DESCRIPTION
20-55-9411	-06	Cages for size -06 hose
20-55-9412	-08	Cages for size -08 hose
20-55-9413	-10	Cages for size -10 hose
20-55-9414	-12	Cages for size -12 hose

Clips Hose / Cage Connection

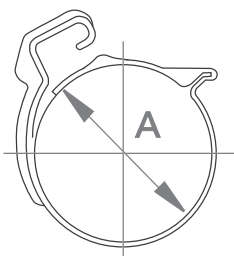

PART NUMBER	A REF	DESCRIPTION
20-55-9415	18 mm	Clips for size -06 hose
20-55-9416	20.5 mm	Clips for size -08 hose
20-55-9417	23 mm	Clips for size -10 hose
20-55-9418	27.5 mm	Clips for size -12 hose

E-Z Clip System™

Assembly Tools

Pliers / Connecting Tool



PART NUMBER	DESCRIPTION
FT1357	Connecting Tool

Core Tool

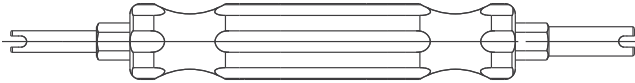

PART NUMBER	DESCRIPTION
FT1406	Core Tool

E-Z Clip System™

Assembly Instructions

Step 1. Cut the Hose

Cut the hose to proper length with an appropriate cutting tool. Aeroquip's hand-held hose cutter (FT1356) has been specially designed for cutting all non-wire reinforced hose, such as GH134 Multi-Refrigerant hose. Be sure the cut is made square to the hose length.



Step 2. Slip on Two Clips

Install two proper-sized clips onto the cut end of the hose. Orientation of the clips does not affect the performance of the connection. However, for ease of assembly, both clips should have the same orientation.

NOTE: Failure to slide the clips over the hose at this time will require the clips to be stretched over the hose or fitting later. This may permanently damage the clip.



Step 3. Oil the Nipple

Lubricate the nipple with a generous amount of the refrigeration or A/C system's compressor lubricating oil. This MUST be done to lower the force of nipple insertion.

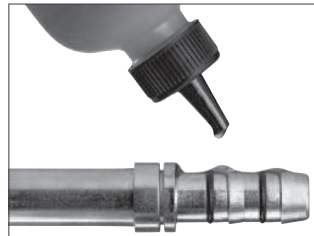

Step 4. Insert the Nipple into the Hose

Insert the nipple into the hose. To ensure that the nipple is fully inserted, check the gap between the cut end of the hose and the shoulder on the nipple. Care should be taken to avoid kinking or other damage to the hose during nipple insertion.

NOTE: Be sure to wipe excess oil from the nipple and hose.



Step 5. Snap on the Cage

Snap the cage into the groove on the nipple. The arms should extend over the hose length. When the cage has been correctly installed in the cage groove, the cage will be able to rotate in the groove. This step MUST be performed to ensure:

1. The clips will be located over the O-rings on the nipple.
2. The connection will be compatible with the connection's pressure rating.



E-Z Clip System™

Assembly Instructions (cont.)

Step 6: Slide the Clips

Slide the clips over the cage arms and into the channels on each arm.

Step 7: Close the Clips

Use the FT1357 pliers to close the clips. The pliers should be positioned squarely on the clip connection points and should remain square during the closing of the clip.

Nose of the pliers should be firmly seated under the assembly bump and lock latch.

If the pliers are not kept square during closing of the clip, the clasp may have an offset. Use the pliers to correct the clasp alignment.

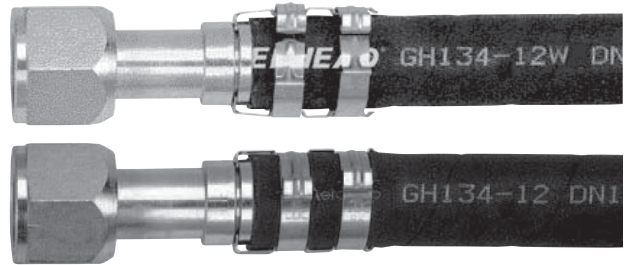

For easiest assembly, the clasp should be closed between the cage arms.

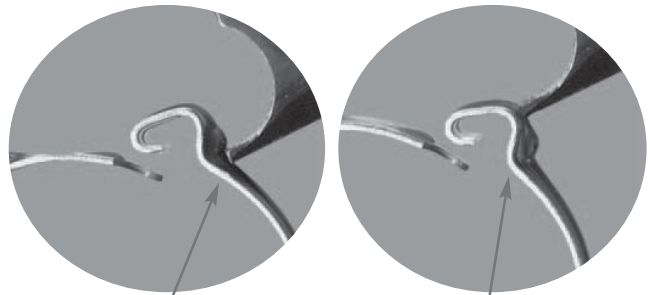

Correct

Incorrect

Notice

E-Z Clip components should not be reused. For recommendations on cleaning and routing hose assemblies, please consult Aeroquip Assembly Bulletin JA776.

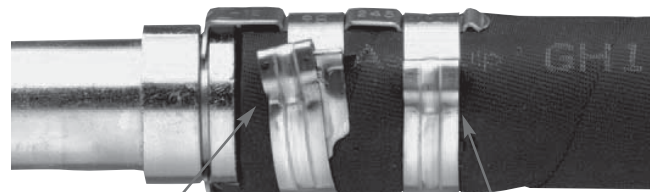

Incorrect

Correct



CAUTION: Failure to follow these assembly instructions and/or the use of Aeroquip hose with fittings supplied by other manufacturers may result in unreliable and unsafe hose assemblies, which may result in sudden or unintended escape of refrigerant gases. Personal injury and/or violations of EPA regulations may occur as a consequence. Aeroquip recommends adherence to all guidelines, including EPA guidelines, concerning the service of refrigerant systems.

Coil Cleaners

Carrier
TRANSICOLD
20 SERIES
PERFORMANCE PARTS

The Coil Cleaners section is designed to provide you with a complete guide to our coil cleaners and chemicals product line.

This section includes:





- HVACR Coil Cleaners
- Coil Sanitizers
- Insulation Products
- Gas Leak Detectors
- System Flush
- Specialty Products
- Sprayers



HVACR Coil Cleaners & Chemicals

Coil Cleaners		
	<p>Cal-Brite – Low pH or acid-based product developed for cleaning evaporator and condenser coils, safe yet aggressive!</p> <p>Package Size: 4 – 1 gallon jugs</p>	Part #: NU4133-08
	<p>Cal-Shield w/Teflon – Contains Teflon to shield and protect finned cooling and heating coils from dirt and corrosion</p> <p>Package Size: 4 – 1 gallon jugs</p>	Part #: NU4148-08
	<p>Cal-Shield w/Teflon – Contains Teflon to shield and protect finned cooling and heating coils from dirt and corrosion</p> <p>Package Size: 6 – 1 quart bottles</p>	Part #: NU4148-32
	<p>Tri-Pow'r – Alkaline detergent/degreaser for cleaning air cooled condensers, evap coils, permanent filters, fan blades, motors, etc.</p> <p>Package Size: 4 – 1 gallon jugs</p>	Part #: NU4371-88
	<p>Evap Foam No Rinse – High performance, heavy-duty detergent. Foaming, no rinse, aerosol evaporator coil cleaner, foams out dirt!</p> <p>Package Size: 6 – 18 ounce cans</p>	Part #: NU4171-75
	<p>Nu-Brite – Revolutionary strong, foaming condenser coil cleaner, Alkaline. The Acid alternative!</p> <p>Package Size: 4 – 1 gallon jugs</p>	Part #: NU4291-08
	<p>Nu-Brite – Revolutionary strong, foaming condenser coil cleaner, Alkaline. The Acid alternative!</p> <p>Package Sizes: 2.5 gallon pail 55 gallon drum</p>	<p>2.5 Gallon Part #: NU4291-05</p> <p>55 Gallon Part #: NU4291-01</p>

HVACR Coil Cleaners & Chemicals

Coil Sanitizers		
	<p>Bio-Fresh CD – A concentrated, ready to use bacteriostat-fungistat-depdorizer formulated for use in HVACR systems. 1 Qt. Sanitizes evap coils and drain pans, deodorizes and kills bacteria</p> <p>Package Size: 12 – 1 quart bottles</p>	Part #: NU4126-34
	<p>Bio-Fresh CD – – A concentrated, ready to use bacteriostat-fungistat-depdorizer formulated for use in HVACR systems. 1 Qt. Sanitizes evap coils and drain pans, deodorizes and kills bacteria</p> <p>Package Size: 4 – 1 gallon jugs</p>	Part #: NU4126-38
	<p>PanPads - ACP – Condensate drain pads prevent bacteria & slime in pans. Combats a broad spectrum of harmful bacteria.</p> <p>Package Size: 24 pads</p>	Part #: NU4295-34
Insulation Products		
	<p>Insulation Slugs – Thumbing grade slugs for plugging holes</p> <p>Package Size: 24 – 2lb. Boxes</p>	Part #: NU4216-92
	<p>Cork Insulation Tape – Insulation tape for wrapping refrigerant lines</p> <p>Package Size: 12 – 2” x 30’ Rolls</p>	Part #: NU4217-W3

HVACR Coil Cleaners & Chemicals

Insulation Products (cont.)		
	<p>Foam Insulation Tape – Insulation tape for wrapping refrigerant lines</p> <p>Package Size: 12 – 2” x 30’ Rolls</p>	<p>Part #: NU4218-W3</p>
	<p>Nu-Foam Insulation Foam – A triple expanding foam that insulates as well as seals cracks, crevices and other openings. Created for refrigeration, air conditioning and heating pipes and tubing.</p> <p>Package Size: 9 oz or 20 oz Cans</p>	<p>9 oz Part #: NU4293-04</p> <p>20 oz Part #: NU4293-75</p>
Gas Leak Detectors		
	<p>Cal-Blue – Gas leak detector</p> <p>Package Size: 4 – 1 gallon jugs</p>	<p>Part #: NU4182-08</p>
	<p>Cal-Blue – Gas leak detector with trigger spray</p> <p>Package Size: 12 – 1 quart bottles</p>	<p>Part #: NU4182-24</p>
	<p>Cal-Blue – Gas leak detector with dauber in cap</p> <p>Package Size: 24 – 6 ounce bottles</p>	<p>Part #: NU4182-53</p>

HVACR Coil Cleaners & Chemicals

System Flush		
	<p>Rx11 Flush “2 in 1” Display – Rx11 flushing solvent for burnouts and oil removal. 2 cylinder pack w/ valve</p> <p>Package Size: 1 – 2 cylinder pack</p>	<p>Part #: NU4300-10</p>
	<p>Rx11 Flush – Rx11 flushing solvent for burnouts and oil removal. Single cylinder.</p> <p>Package Size: 4 single cylinders</p>	<p>Part #: NU4300-11</p>
	<p>Rx11 Flush – Rx11 flushing solvent for burnouts and oil removal. 50 ton capacity.</p> <p>Package Size: 15lb. cylinder</p>	<p>Part #: NU4300-15</p>
	<p>Rx11 Flush Fitting Assembly – Access valve for single Rx11 cylinders</p> <p>Package Size: 1 valve</p>	<p>Part #: NU4300-99</p>
	<p>Rx Acid Scavenger – Acid neutralizer for refrigeration oil. 2oz treats up to 1 gallon of contaminated oil.</p> <p>Package Size: 6 – 2 ounce bottles</p>	<p>Part #: NU4301-02</p>

HVACR Coil Cleaners & Chemicals

Specialty Products

	<p>Kleen-N-Toss – Scrubbing hand cleaning towels with special cleanser</p> <p>Package Size: 6 – 72 towel buckets</p>	<p>Part #: NU4230-72</p>
	<p>Phase III– Refrigeration oil acid test kit</p> <p>Package Size: 24 kits</p>	<p>Part #: NU4320-W8</p>
<h3>Sprayers</h3>		
	<p>Sprayer, no. 50P Poly – Pump sprayer for coil cleaners, ½ gallon capacity.</p> <p>Package Size: 1 sprayer</p>	<p>Part #: NU4770-00</p>
	<p>Sprayer, no. 220CP – Pump sprayer for coil cleaners, 2 gallon capacity.</p> <p>Package Size: 1 sprayer</p>	<p>Part #: NU4771-30</p>
	<p>Sprayer, no. 300P – Pump sprayer for coil cleaners, 3 gallon capacity.</p> <p>Package Size: 1 sprayer</p>	<p>Part #: NU4772-00</p>
	<p>Coil Gun – Hose end sprayer with mixing valve to dilute coil cleaners</p> <p>Package Size: 1 gun</p>	<p>Part #: NU4774-00</p>

CARRIER TRANSICOLD

CLEANERS



Specifications are subject to change without notice. TK is a trademark of Thermo King Corporation.
©2011 Carrier Corporation • Printed in USA 1-11 • A member of the United Technologies Corporation family. Stock symbol UTX. • Form 62-10616 Rev. F



Carrier

A United Technologies Company

Carrier Transicold Division
Carrier Corporation
Performance Parts Group
P.O. Box 4805
Carrier Parkway
Syracuse, NY 13221 USA

www.transportparts.carrier.com



MIX
Paper from
responsible sources
FSC® C006895