

Bill of Materials Listing

TransArctic Canada Inc.

2/11/2015
Page 1 of 1

Product Number	Description	Date	Weight	Uof M	Yield
Line Component Prod# Description	Bin	Unit	Qty		
KMC62562	Mt Kit, ISB, D3/T3RE, F400, 12V, '13	9/5/2012	170.61		0
10 BEL32007	Belt, Banded B gr,2007mm (79") (RBX76-2)	each	1		
20 KBB00001	Mt Kit, Platform, Transit, ADM, '12	each	1		
30 KCF40000	Kit, Comp, F400, Conversion, '12	each	1		
40 KFB67001	Kit, Found'n, BB T3/D3RE, ISB, '13	each	1		
50 KPC67001	Kit, Pulley, ISB, T3/D3RE, '12	each	1		

Bill of Materials Listing

TransArctic Canada Inc.

6/27/2013
Page 1 of 1

Product Number		Description	Bin	Date	Weight	Uof M	Yield
Line	Component Prod#	Description		Unit	Qty		
KBB00001		Mt Kit, Platform, Transit, ADM, '12		06/20/12	75.97		0
10	BMZ01034	Bkt, Spring, Support Arm, ADM, '12		each	1		
20	BMZ01035	Bkt, Main, Pivot, Ass'y, ADM Transit,'12		each	1		
30	BMZ01037	Bkt, Fork, Knuckle-Joint, Adm, '12		each	1		
40	BMZ01038	Bkt, Main, Base Pl, ADM, '12		each	1		
50	BMZ01040	Bkt, Ass'y, THRD Rod, Isolator, ADM, '12		each	1		
60	BMZ01041	Shaft Key, 8mm W x7mm H x13.7mm Long		each	2		
70	BMZ01042	Vibration Isolator, Bar, 9.63 x 2 x 1.50		each	2		
80	BMZ01044	Bkt, Cradle, Pivot, Adm Transit, '12		each	1		
90	BMZ01047	Bkt, Bar, Slide Nut, ADJ, Trans ADM, '12		each	2		
100	BTS08100	Bolt, Grease,Nipple,1/2-13 x 1.0"		each	1		
105	FTS04007	Ftg, Grease, Nipple, 1/4-28 UNF-2A,Brass		each	1		
110	PIS01010	Shaft, Stl, Grease, ADM Transit, '12		each	1		
120	SPR00002	Spring, Comp, R/H, 110 x 50 x 8.4, Red		each	1		
130	WFS16001	Washer, Flat, Dbl Step, 17mm, 50mm, Plt		each	1		
140	WFS27001	Washer, Flat, Dbl Step, 27mm, 63.5, Plt		each	1		
150	KBB000025	Bag Kit, Fasteners, KBB00001		each	1		

Bill of Materials Listing

TransArctic Canada Inc.

2/11/2015
Page 1 of 1

Product Number	Description	Date	Weight	Uof M	Yield
Line Component Prod#	Description	Bin Unit	Qty		
KBB00025	Bag Kit, Fasteners, KBB00001		8/1/2012	3.98	0
5	BTQ08101		Bolt, Hex, 1/2-20unf, 1.00", 8, Plt	each	6
10	BTQ08126		Bolt, Hex, 1/2-20unf, 1.25", 8, Plt	each	6
15	BTQ08100		Bolt, Hex, 1/2-13unc, 1.00", 8, Plt	each	1
20	BTQ08150		Bolt, Hex, 1/2-13unc, 1.5", 8, Plt	each	9
30	BTQ10351		Bolt, Hex, 5/8-18unf, 3.5", 8, PLT	each	1
50	NTQ08000		Nut, Hex, 1/2-13unc, 8, Plt	each	5
60	NTQ10000		Nut, Hex, 5/8-11unc, 8, Plt	each	2
65	NTQ10001		Nut, Hex, 5/8-18unf, 8, Plt	each	1
70	WFS08001		Washer, Flat, 1/2", 8, USS, Plt	each	2
100	WFQ08000		Washer, Flat, 1/2", 8, Plt	each	14
110	WFQ10000		Washer, Flat, 5/8", 8, Plt	each	2
120	WLQ08000		Washer, Lock, 1/2", 8, Plt	each	23
130	WLQ10000		Washer, Lock, 5/8", 8, Plt	each	2

Bill of Materials Listing

TransArctic Canada Inc.

6/27/2013
Page 1 of 1

Product Number	Description	Date	Weight	Uof M	Yield
Line Component Prod# Description	Bin	Unit	Qty		
KCF40000	Kit, Comp, F400, Conversion, '12	08/07/12	4.17		0
5 PAC08080	Pack, Carton, 8" x 8" x 3 1/2", 32 ECT	each	1		
10 BMZ01045	Bkt, RR Bar, 4UFC/ F400, Conv, ADM,'12	each	1		
20 BMZ01046	Bkt, Frt Bar, 4UFC/ F400, Conv, ADM,'12	each	1		
30 KBF40000	Bag Kit, Fasteners, KCF40000	each	1		

Bill of Materials Listing

TransArctic Canada Inc.

6/27/2013
Page 1 of 1

Product Number	Description	Date	Weight	Uof M	Yield
Line Component Prod#	Description	Bin Unit	Qty		
KBF40000	Bag Kit, Fasteners, KCF40000		09/21/12	1.31	0
10	BTQ08200		Bolt, Hex, 1/2-13unc, 2.0", 8, Plt	each	2
20	BTQ08350		Bolt, Hex, 1/2-13unc, 3.5", 8, Plt	each	2
30	CSF10031		Capscrew, FH, 10 x 1.5 x 30mm, 10.9,Plt	each	2
40	CSF10071		Capscrew, FH, 10 x 1.5 x 70mm, 10.9,Plt	each	2
50	NTQ08000		Nut, Hex, 1/2-13unc, 8, Plt	each	4
60	WFQ08000		Washer, Flat, 1/2", 8, Plt	each	4
70	WLQ08000		Washer, Lock, 1/2", 8, Plt	each	4

Bill of Materials Listing

TransArctic Canada Inc.

6/27/2013
Page 1 of 1

Product Number	Description	Date	Weight	Uof M	Yield
Line Component Prod#	Description	Bin Unit	Qty		
KFB67001	Kit, Found'n, BB D3RE, ISB, '13		08/20/12	70.31	0
10	BFB00001	Bkt, Foundation, Main, BB D3RE, '13	each	1	
20	BMZ01050	Bkt, Frt, Angle, Weldmt, BB, D3RE, '13	each	1	
30	PUL80074	Pulley, Idler, B/S, Wide, 76d (89102)	each	2	
40	SCD25412	Spacer, Col, Drl,25.4mm x 25.4o x 12.3i	each	2	
50	SLV17012	Sleeve, Pulley, 16.9o x 22.23mm x 12.32i	each	2	
60	KBB90020	Bag Kit, Fasteners, KFB67001	each	1	

Bill of Materials Listing

TransArctic Canada Inc.

6/27/2013
Page 1 of 1

Product Number	Description	Date	Weight	Uof M	Yield
Line Component Prod#	Description	Bin Unit	Qty		
KBB90020	Bag Kit, Fasteners, KFB67001		08/20/12	1.45	0
10	BTC12080		Bolt, Hex, 12 x 1.75 x 80mm, 10.9,Plt,FT	each	2
20	BTQ06150		Bolt, Hex, 3/8-16unc, 1.50", 8, Plt	each	2
25	BTQ08150		Bolt, Hex, 1/2-13unc, 1.5", 8, Plt	each	4
30	NTA12000		Nut, Hex, 12 x 1.75, 8.8, Plt	each	2
40	NTP06000		Nut, Hex, 3/8-16unc, 5, Plt	each	2
45	NTQ08000		Nut, Hex, 1/2-13unc, 8, Plt	each	4
50	WFA12000		Washer, Flat, 12mm, 8.8, Plt	each	2
60	WFN06000		Washer, Flat, 3/8", 2, Plt	each	4
65	WFQ08000		Washer, Flat, 1/2", 8, Plt	each	8
70	WLA12000		Washer, Lock, 12mm, 8.8, Plt	each	2
80	WLP06000		Washer, Lock, 3/8", 5, Plt	each	2
90	WLQ08000		Washer, Lock, 1/2", 8, Plt	each	4

Bill of Materials Listing

TransArctic Canada Inc.

6/27/2013
Page 1 of 1

Product Number	Description		Date	Weight	Uof M	Yield
Line Component Prod#	Description	Bin	Unit	Qty		
KPC67001	Kit, Pulley, ISB, D3RE, '12		05/13/08	18.08		0
10	PUL67323		each	1		
20	BTC12040		each	4		

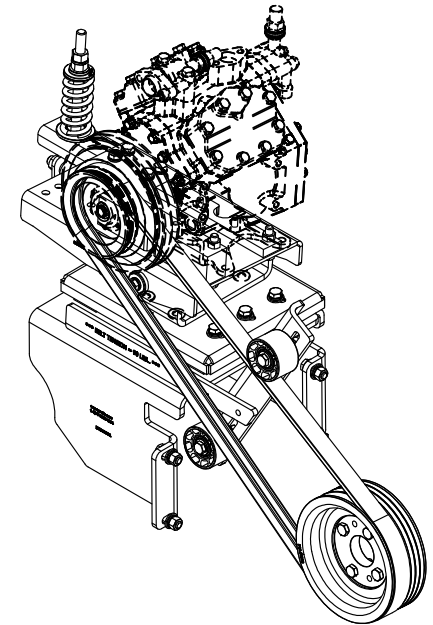
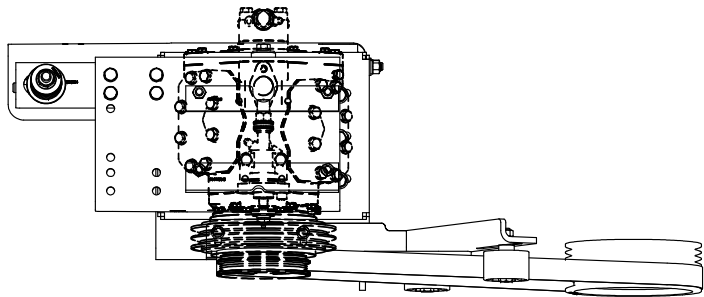

ISOMETRIC VIEW

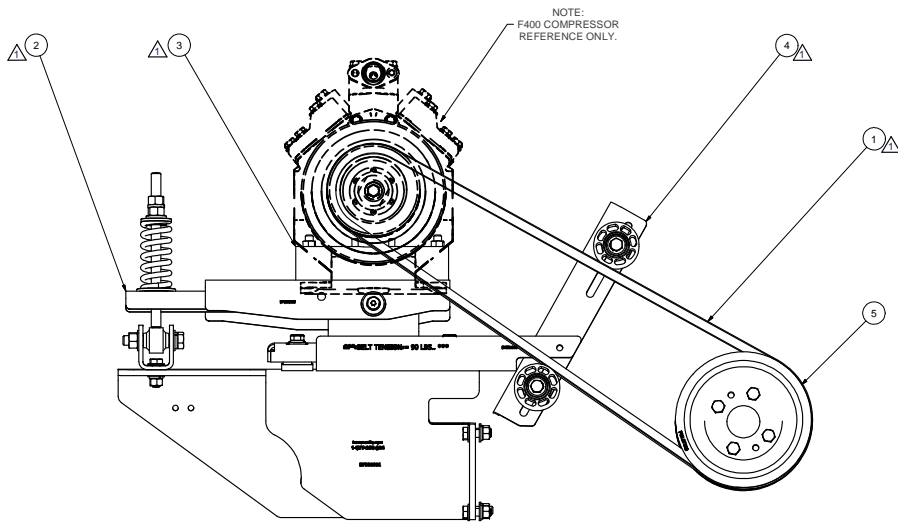

NOTE:
F400 COMPRESSOR
REFERENCE ONLY.

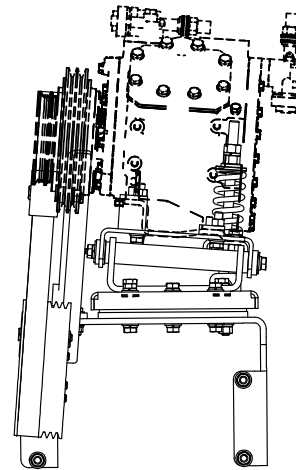

NOTES:

- 1) USE SERVICABLE THREADLOCKER ON ALL FASTENERS TO ENGINE COMPONENTS AND TORQUE **ALL** BOLTS TO S.A.E. SPECIFICATIONS.
- 2) SEE 'TRANSARCTIC A/C COMPRESSOR MOUNT INSTALLATION DISCLAIMER'.

ITEM	QTY	U/M	PART NUMBER	DESCRIPTION
5	1	EACH	KPC67001	KIT, PULLEY, ISB, D3RE, '12
4	1	EACH	KFB67001	KIT, FOUNDN, BB D3RE, ISB, '13
3	1	EACH	KCF40000	MT KIT, COMP, 4UFC/F400, CONVERSION, '12
2	1	EACH	KBB0001	MT KIT, PLATFORM, TRANSIT, ADM, '12
1	1	EACH	BEL32007	BELT, BANDED B GR, 2007mm (79") (RBX76-2)

TRANSARCTIC INC.

REV	DESCRIPTION	DATE	BY
1	GENERAL REVISION	2/10/2015	JRR
0	RELEASED TO PRODUCTION	9/6/2012	JRR
1	RELEASED TO PRODUCTION	9/6/2012	Vaj Jakovlew
2	RELEASED TO PRODUCTION	9/6/2012	James Stewart
3	RELEASED TO PRODUCTION	9/6/2012	Ron Ingram
4	RELEASED TO PRODUCTION	9/6/2012	Dale Mason

BILL OF MATERIALS		TITLE	
DRAWN	jrodriquez	9/6/2012	
CHECKED	Vaj Jakovlew	9/6/2012	
APPROVED	Dale Mason	9/6/2012	
DRAWING UNIT OF MEASURE		MM (INCH)	
SCALE		1:4	
DWG NO		KMC62562	
REV		1	
SHEET		1	OF 1

THIS DRAWING CONTAINS PROPRIETARY CONFIDENTIAL INFORMATION OWNED BY TRANSARCTIC CANADA INC. THE DOCUMENT AND THE INFORMATION IT IS NOT TO BE USED, DISCLOSED OR REPRODUCED WITHOUT EXPRESS WRITTEN PERMISSION OF THE COMPANY.

UNSPECIFIED TOLERANCES: ALL DIMS ±0.25
 ONE DECIMAL PLACE (X) ±0.10
 TWO DECIMAL PLACE (XX) ±0.05
 THREE DECIMAL PLACE (XXX) ±0.025
 FRACTIONAL (1/16) ANGULAR ±30'

THIRD ANGLE PROJECTION

8 7 6 5 4 3 2 1

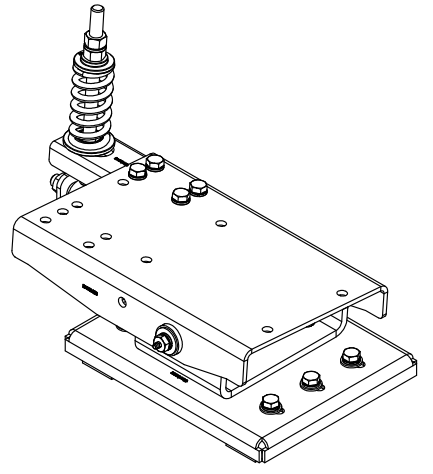
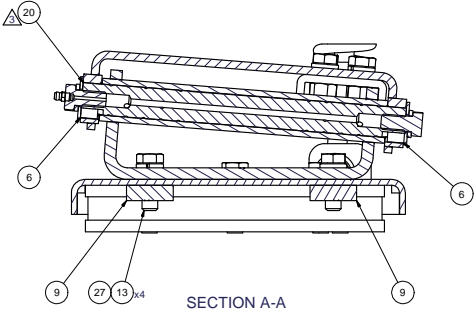
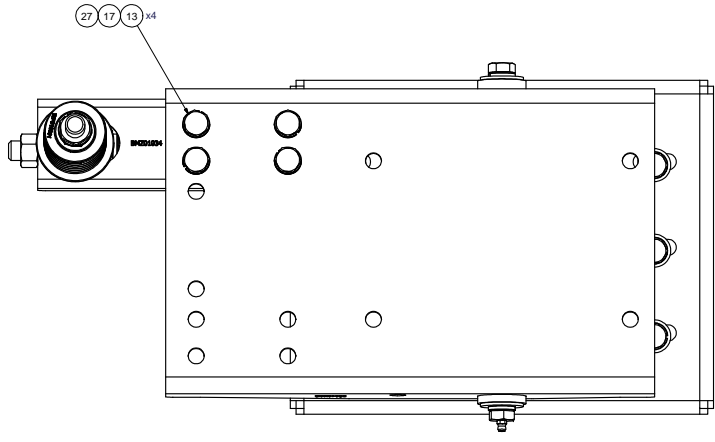

ISOMETRIC VIEW
SCALE 1/3

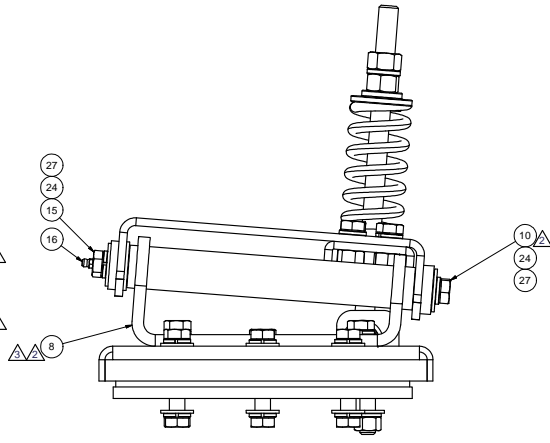
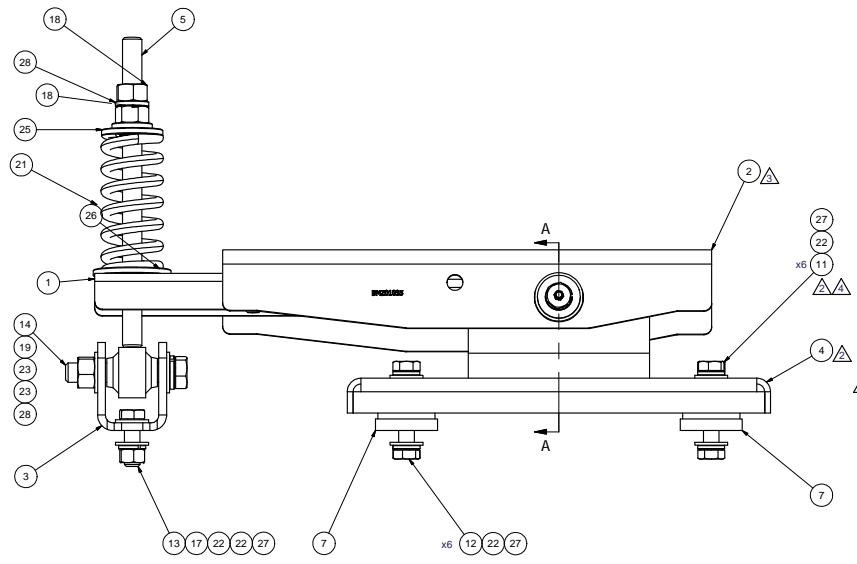

28	2	EACH	WLO10000	WASHER, LOCK, 5/8", 8, PLT
27	23	EACH	WLO08000	WASHER, LOCK, 1/2", 8, PLT
26	1	EACH	WFS27001	WASHER, FLAT, DBL STEP, 28mm, 63.5, PLT
25	1	EACH	WFS16001	WASHER, FLAT, DBL STEP, 16mm, 50mm, PLT
24	2	EACH	WFS08001	WASHER, FLAT, 1/2", 8, USS, PLT
23	2	EACH	WFO10000	WASHER, FLAT, 5/8", 8, PLT
22	14	EACH	WFO08000	WASHER, FLAT, 1/2", 8, PLT
21	1	EACH	SPR00002	SPRING, COMP, R/H, 110 x 50 x 8.4, RED
20	1	EACH	PI501010	SHAFT, STL, GREASE, ADM TRANSIT, '12
19	1	EACH	NT010001	NUT, HEX, 5/8-18UNF, 8, PLT
18	2	EACH	NT010000	NUT, HEX, 5/8-11UNC, 8, PLT
17	5	EACH	NT008000	NUT, HEX, 1/2-13UNC, 8, PLT
16	1	EACH	FTS04007	FTG, GREASE, NIPPLE, 1/4-28 UNF-2A, BRASS
15	1	EACH	BTS08100	BOLT, GREASE, NIPPLE, 1/2-13 x 1.00"
14	1	EACH	BTO10351	BOLT, HEX, 5/8-18UNF x 3.50, 8, PLT
13	9	EACH	BTO08150	BOLT, HEX, 1/2-13UNC x 1.50, 8, PLT
12	6	EACH	BTO08126	BOLT, HEX, 1/2-20UNF x 1.25, 8, PLT
11	6	EACH	BTO08101	BOLT, HEX, 1/2-20UNF x 1.00, 8, PLT
10	1	EACH	BTO08100	BOLT, HEX, 1/2-13UNC x 1.00, 8, PLT
9	2	EACH	BMZ01047	BKT, BAR, SLIDE NUT, ADJ, TRANS ADM, '12
8	1	EACH	BMZ01044	BKT, ASSY, CRADLE, PIVOT, ADM TRANSIT, '12
7	2	EACH	BMZ01042	VIBRATION ISOLATOR, BAR, 9.63 x 2 x 1.50
6	2	EACH	BMZ01041	Shaft Key, 5/16" SQ x .540" Long
5	1	EACH	BMZ01040	BKT, ASSY, THRD ROD, ISOLATOR, ADM, '12
4	1	EACH	BMZ01038	BKT, MAIN, BASE PL, ADM, '12
3	1	EACH	BMZ01037	BKT, FORK, KNUCKLE-JOINT, ADM, '12
2	1	EACH	BMZ01035	BKT, MAIN, PIVOT, ASSY, ADM TRANSIT, '12
1	1	EACH	BMZ01034	BKT, SPRING, SUPPORT ARM, ADM, '12

ITEM				QTY	U/M	PART NUMBER	DESCRIPTION
BILL OF MATERIALS							
4	1	WAS (12 BT08126, ADD 8) BT08101	01/20/16	VAL/J	DRAWN	JRodriguez	7/3/2012
3	1	REVISED BMZ01038 44 & P182010	10/15/2012	JRR	CHECKED		
2	1	REVISED BMZ01038 44, 1038 BT08101	01/19/2012	JRR		Vaj, Jakovlew	7/3/2012
1	1	GENERAL REVISION	01/02/2012	JRR		GA	
0	1	RELEASED TO PRODUCTION	7/3/2012	JRR		MFS	
REV/ECN		DESCRIPTION	DATE	BY		Jarvis Stewart	7/3/2012
						Ron Ingram	7/3/2012
						Dale Mason	7/3/2012
THIS DRAWING CONTAINS PROPRIETARY CONFIDENTIAL INFORMATION OWNED BY TRANSARGTIC CANADA INC. THE DOCUMENT AND THE INFORMATION IT IS ARE NOT TO BE USED, DISCLOSED OR REPRODUCED WITHOUT EXPRESS WRITTEN PERMISSION OF THE COMPANY.							
UNSPECIFIED TOLERANCES:				MM (DIM)			
ONE DECIMAL PLACE (X.0)	30	FRF					
TWO DECIMAL PLACE (X.00)	25	FRF					
THREE DECIMAL PLACE (X.000)	20	FRF					
FRACTIONAL (X.125)	20	FRF					
ANGULAR (X.001)	20	FRF					
THIRD ANGLE PROJECTION							
DRAWING UNIT OF MEASURE:				MM (INCH)			
SCALE:				1:2			
DWG NO:				KBB00001			
REV:				4			
SHEET:				1	OF 1		

NOTES:
1) USE SERVICABLE THREADLOCKER ON ALL FASTENERS TO ENGINE COMPONENTS AND TORQUE ALL BOLTS TO S.A.E. SPECIFICATIONS.
2) SEE "TRANSARGTIC A/C COMPRESSOR MOUNT INSTALLATION DISCLAIMER".

8 7 6 5 4 3 2 1

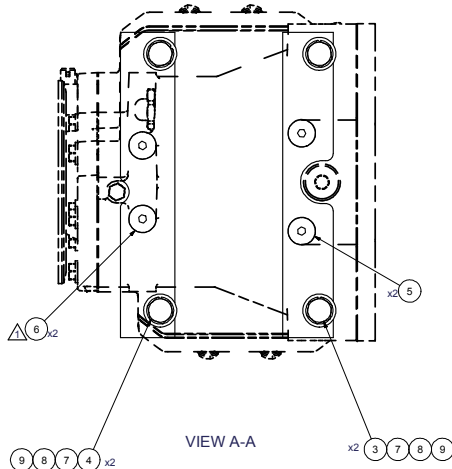
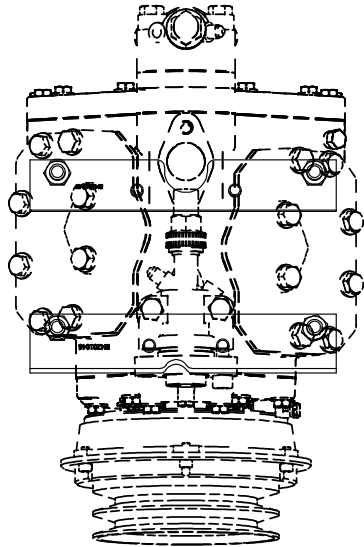

NOTE:
F400 COMPRESSOR
REFERENCE ONLY.

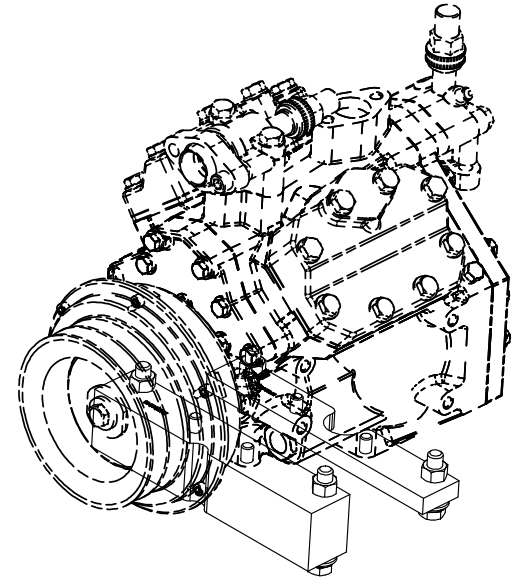
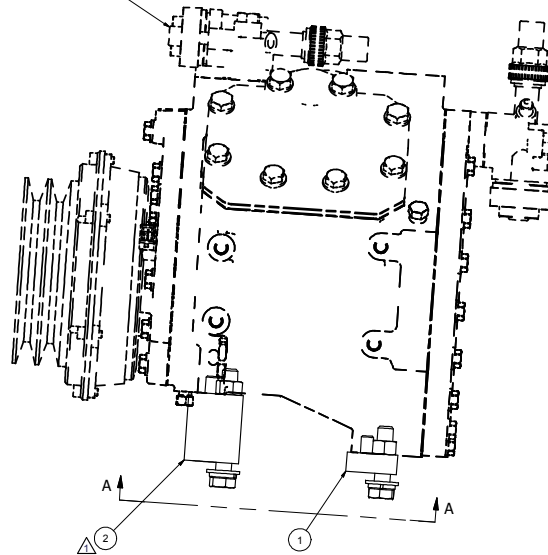
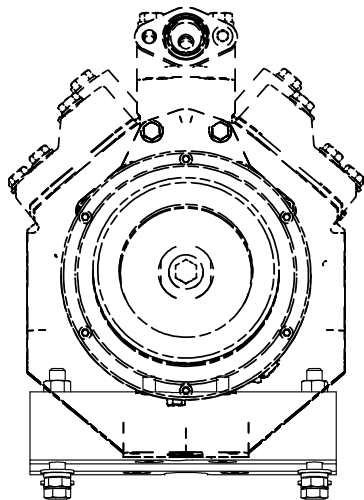

ISOMETRIC VIEW

NOTES:

- 1) USE SERVICABLE THREADLOCKER ON ALL FASTENERS TO ENGINE COMPONENTS AND TORQUE ALL BOLTS TO S.A.E. SPECIFICATIONS.
- 2) SEE "TRANSARCIC A/C COMPRESSOR MOUNT INSTALLATION DISCLAIMER".

ITEM	QTY	U/M	PART NUMBER	DESCRIPTION
9	4	EACH	WLQ08000	WASHER, LOCK, 1/2", 8, PLT
8	4	EACH	WFO08000	WASHER, FLAT, 1/2", 8, PLT
7	4	EACH	NTQ08000	NUT, HEX, 1/2-13UNC, 8, PLT
6	2	EACH	CSF10071	CAPSCREW, FH, 10 x 1.5 x 70mm, 10.9, PLT
5	2	EACH	CSF10031	CAPSCREW, FH, 10 x 1.5 x 30mm, 10.9, PLT
4	2	EACH	BTQ08350	BOLT, HEX, 1/2-13UNC x 3.50, 8, PLT
3	2	EACH	BTQ08200	BOLT, HEX, 1/2-13UNC x 2.50, 8, PLT
2	1	EACH	BMZ01046	BKT, FRT BAR, 4UFC/ F400, CONV, ADM, '12
1	1	EACH	BMZ01045	BKT, RR BAR, 4UFC/ F400, CONV, ADM, '12

BILL OF MATERIALS

DRAWN	8/7/2012
Jodriguez	
CHECKED	
Val Jakovlev	8/7/2012
DATE:	8/7/2012
BY:	James Stewart
DATE:	8/7/2012
BY:	Ron Ingram
DATE:	8/7/2012
BY:	Dale Mason

TRANSARCIG INC.

TITLE
MT KIT, COMP, 4UFC/F400,
CONVERSION, '12

SIZE DWG NO
D KCF40000 REV
SCALE 1:2 SHEET 1 OF 1

1	REVISED BMZ01045 & WAS CRF10088	8/20/2012	JRR
0	RELEASED TO PRODUCTION	8/7/2012	JRR
REV/ECN	DESCRIPTION:	DATE:	BY:
			James Stewart
			Ron Ingram
			Dale Mason

THIS DRAWING CONTAINS PROPRIETARY CONFIDENTIAL INFORMATION OWNED BY TRANSARCIG CANADA INC. THE DOCUMENT AND THE INFORMATION IT CONTAINS ARE NOT TO BE USED, DISCLOSED OR REPRODUCED WITHOUT EXPRESS WRITTEN PERMISSION OF THE COMPANY.

UNSPECIFIED TOLERANCES: (ALL DIM) .005
ONE DECIMAL PLACE (10) .010
TWO DECIMAL PLACE (.100) .005
FRACTIONAL (1/32) .005



DRAWING UNIT OF MEASURE: MM (INCH)

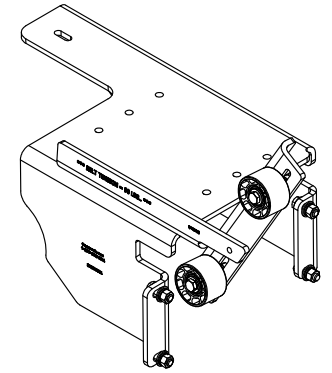
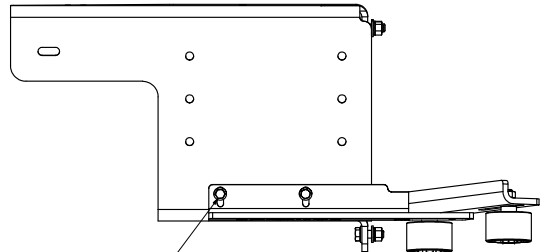

ISOMETRIC VIEW

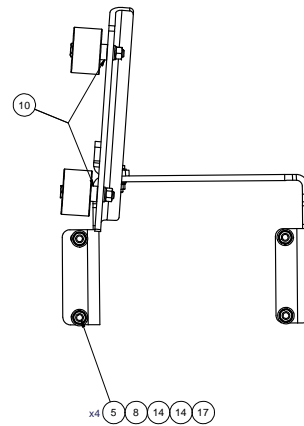
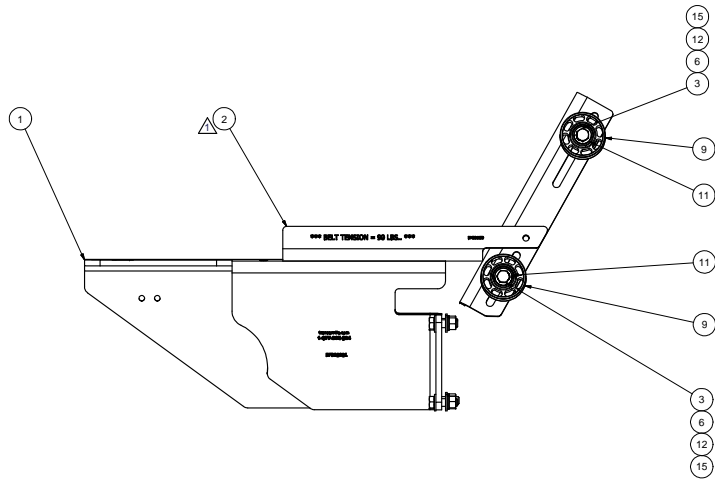

- NOTES:**
 1) USE SERVICABLE THREADLOCKER ON ALL FASTENERS TO ENGINE COMPONENTS AND TORQUE ALL BOLTS TO S.A.E. SPECIFICATIONS.
 2) SEE "TRANSARCTIC A/C COMPRESSOR MOUNT INSTALLATION DISCLAIMER".

ITEM	QTY	U/M	PART NUMBER	DESCRIPTION
17	4	EACH	WLO08000	WASHER, LOCK, 1/2", 8, PLT
16	2	EACH	WLP06000	WASHER, LOCK, 3/8", 5, PLT
15	2	EACH	WLA12000	WASHER, LOCK, 12mm, 8.8, PLT
14	8	EACH	WFO08000	WASHER, FLAT, 1/2", 8, PLT
13	4	EACH	WFO06000	WASHER, FLAT, 3/8", 2, PLT
12	2	EACH	WFA12000	WASHER, FLAT, 12mm, 8.8, PLT
11	2	EACH	SLV17012	SLEEVE, PULLEY, 16.90 x 22.23 mm x12.19l
10	2	EACH	SCD25412	SPACER, COL. DRI. 25.4mm x 25.40 x 12.3l
9	2	EACH	PUL80074	PULLEY, IDLER, BACKSIDE, P8, 74D, 46.27W
8	4	EACH	NTQ08000	NUT, HEX, 1/2-13UNC, 8, PLT
7	2	EACH	NTP06000	NUT, HEX, 3/8-16UNC, 5, PLT
6	2	EACH	NTA12000	NUT, HEX, 12 x 1.75, 8.8, PLT
5	4	EACH	BTQ08150	BOLT, HEX, 1/2-13UNC x 1.50, 8, PLT
4	2	EACH	BTQ06150	BOLT, HEX, 3/8-16UNC, 1.50", 8, PLT
3	2	EACH	BTC12080	BOLT, HEX, 12 x 1.75 x 80mm, 10.9, PLT
2	1	EACH	BMZ01050	BKT. FRNT. ANGLE, WELDINT, BB, D3RE, '13
1	1	EACH	BF800001	BKT. FOUNDATION, MAIN, BB D3RE, '13

TRANSARCTIC INC.

DRAWN	jrodriquez	8/20/2012		
CHECKED				
REVISED P/N	BMZ01050	8/25/2012 JRR		
RELEASED TO PRODUCTION		8/20/2012 JRR		
REV	ECN	DESCRIPTION	DATE	BY
			8/20/2012	JRR
			8/20/2012	James Stewart
			8/20/2012	MFG
			8/20/2012	Ron Ingram
			8/20/2012	Date Mason

TITLE
 KIT, FOUND'N, BB D3RE, ISB, '13
 SIZE D DWG NO KFB67001
 SCALE 1:4 SHEET 1 OF 1

UNSPECIFIED TOLERANCES: ALL DIMS
 ONE DECIMAL PLACE (X1) .05 (FRA) .005
 TWO DECIMAL PLACE (X2) .01 (FRA) .002
 THREE DECIMAL PLACE (X3) .005 (FRA) .001
 FRACTIONAL (X) .005 (FRA) .001



DRAWING UNIT OF MEASURE: MM (INCH)

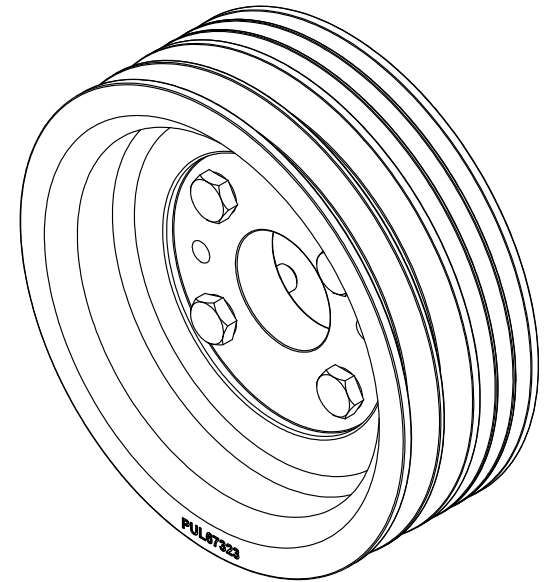
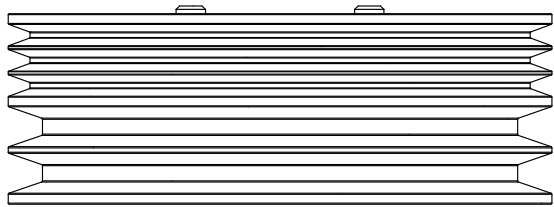

ISOMETRIC VIEW

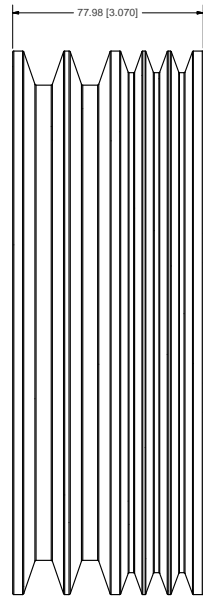
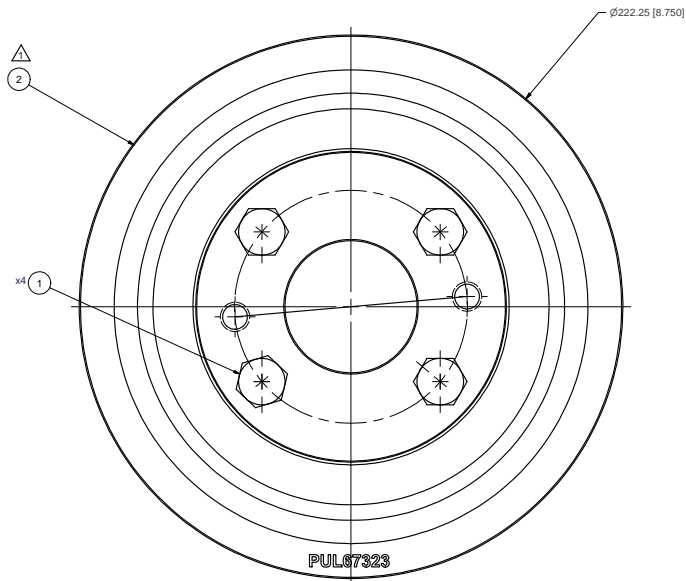

NOTES:

- 1) USE SERVICABLE THREADLOCKER ON ALL FASTENERS TO ENGINE COMPONENTS AND TORQUE ALL BOLTS TO S.A.E. SPECIFICATIONS.
- 2) SEE "TRANSARGTIC A/C COMPRESSOR MOUNT INSTALLATION DISCLAIMER"

ITEM	QTY	U/M	PART NUMBER	DESCRIPTION
2	1	EACH	PUL67323	PULLEY, CRANK, ADD-ON, COMBO, ISB, 2B/3V
1	4	EACH	BTCT2040	BOLT, HEX. 12 x 1.75 x 40mm, 10.9, PLT

BILL OF MATERIALS

DRAWN: jrodriquez		09/14/12	TRANSARGTIC INC.	
CHECKED: Val Jakowlew		09/14/12		
1	WAS PUL67322	06/16/13	VAL	TITLE
0	RELEASED TO PRODUCTION	01/16/2012	GA	
REV	ECN	DESCRIPTION	DATE	BY
				James Stewart
				Ron Ingram
				Date Mason
<p>THIS DRAWING CONTAINS PROPRIETARY CONFIDENTIAL INFORMATION OWNED BY TRANSARGTIC CANADA INC. THE DOCUMENT AND THE INFORMATION IN IT ARE NOT TO BE USED, DISCLOSED OR REPRODUCED WITHOUT EXPRESS WRITTEN PERMISSION OF THE COMPANY.</p>				
UNSPECIFIED TOLERANCES:		MM (INCH)	THIRD ANGLE PROJECTION	
ONE DECIMAL PLACE (X1)	0.1 (0.004)	MM (INCH)		
TWO DECIMAL PLACE (X2)	0.05 (0.002)	MM (INCH)		
THREE DECIMAL PLACE (X3)	0.025 (0.001)	MM (INCH)		
FRACTIONAL (1/16")	ANGULAR (1/2°)	MM (INCH)		
DRAWING UNIT OF MEASURE:		MM (INCH)	SCALE: 1:1	DWG NO: KPC67001
				REV: 1
				SHEET 1 OF 1

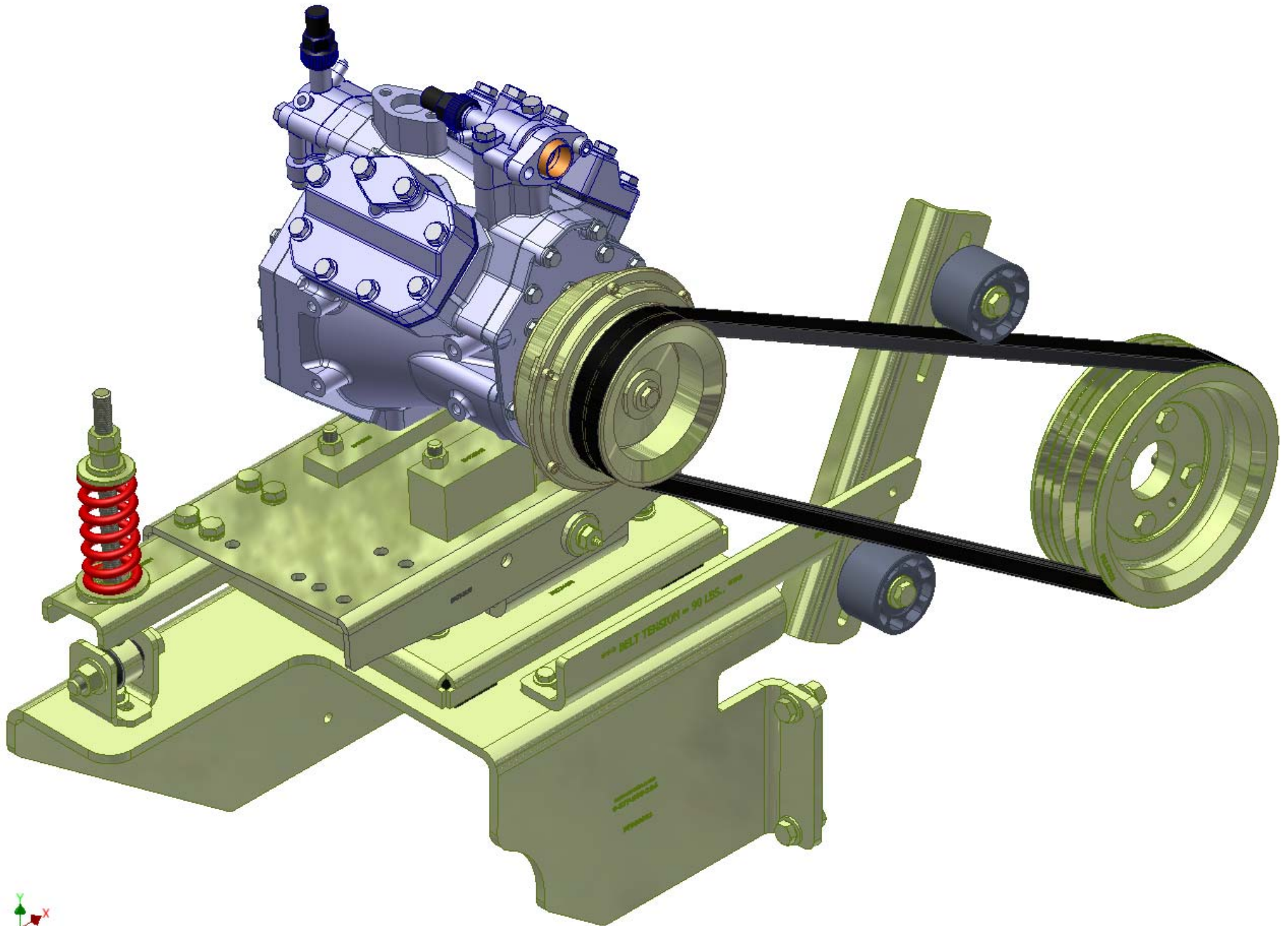

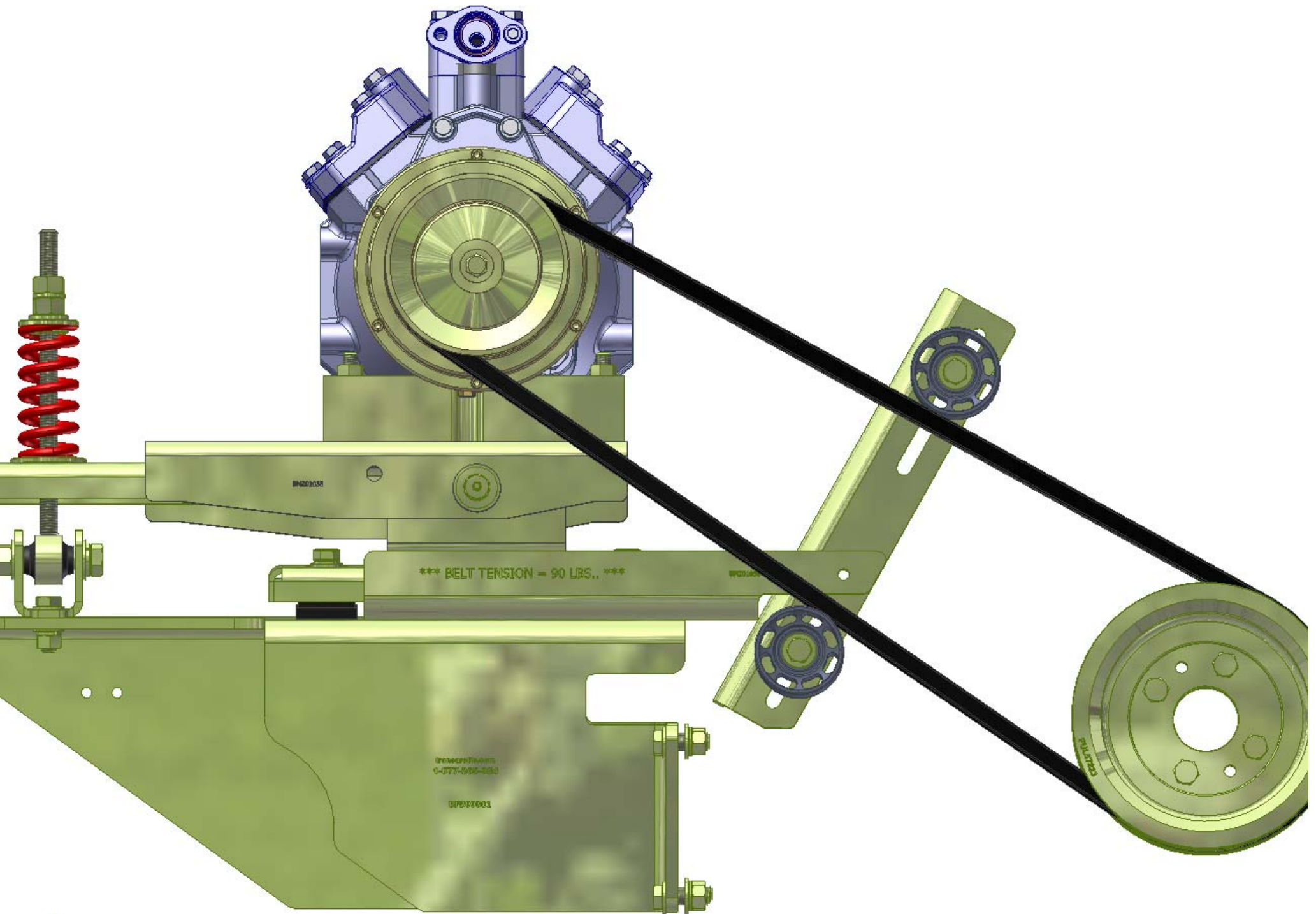

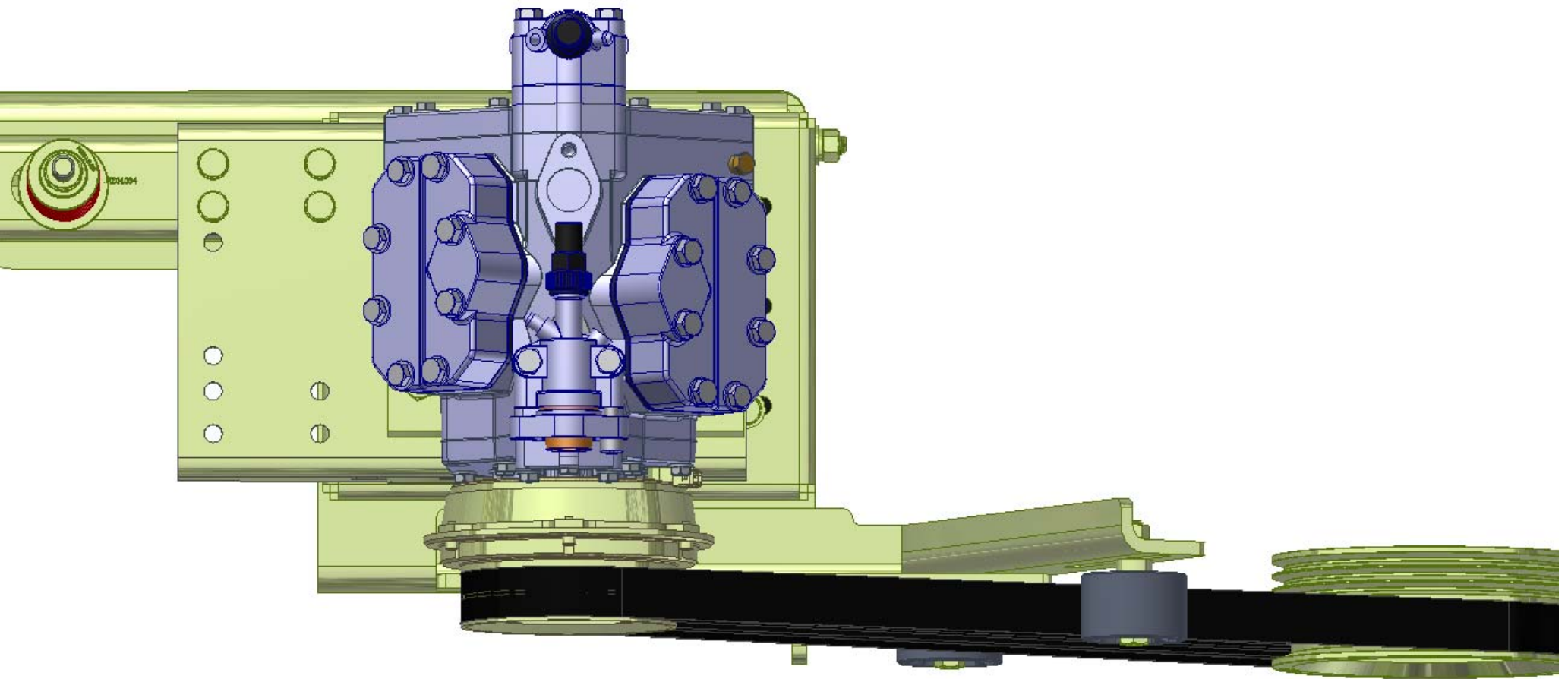

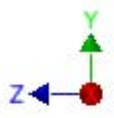
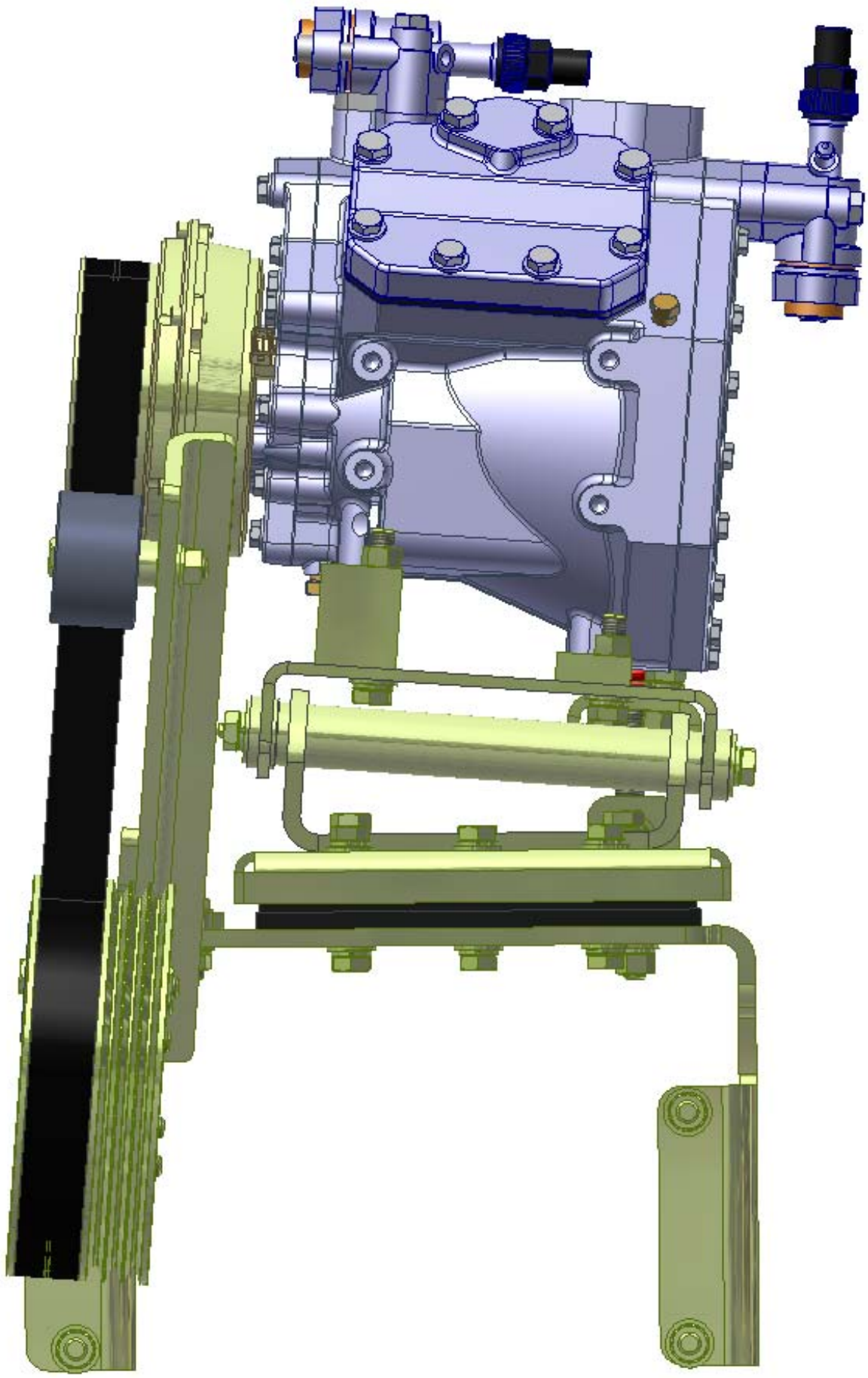

TransArctic A/C Compressor Mount Installation Disclaimer

All compressor mounts should be installed by qualified and trained personnel using proper tools and equipment in safe working conditions following industry standard guidelines for motor vehicle service and repair.

The installer of any compressor mount purchased from TransArctic must undertake all responsibility of issues arising from that compressor bracket being installed on any vehicle. As well as insure that a **proper and sufficient ground** is established between the compressors' clutches and the vehicle's engine. Mount functionality, operation and durability can all be compromised by an incompetent installation.

Due to the many different situations, parameters and application criteria, which are beyond the compressor mount manufacturer's control, TransArctic does not warrant design, durability, or operational functionality of any compressor mount improperly installed by another party.

With no implied guarantees it is the mount installer's strict responsibility to determine safety and functionality, of the compressor mount, at the time of installation.

Please contact TransArctic with any issue arising from installation so we may better improve the product. If you have any reservations about the compressor mount integrity contact TransArctic immediately at 1-877-COLD-AIR.

Mark OEM tensioner location

Install Kit

Check for Interferences

Check to ensure that the proper OEM tensioner orientation is maintained

Run engine with A/C system engaged for at least 10 minutes to run in belt

Check OEM tensioner orientation and adjust as required

Responsabilidad limitada de TransArctic en la instalación del soporte del compresor

Todos los soportes de los compresores deben ser instalados por personas calificadas y entrenadas, usando para ello los equipos y herramientas necesarios para esta labor en buenas condiciones y según las normas y guías para el servicio y/o reparación de motores de vehículos.

El instalador de los soportes comprados en TransArctic asume toda la responsabilidad de cualquier problema que surga en el soporte del compresor al vehículo; de igual manera es responsable que el cable a tierra sea conectado entre el embrague del compresor y el motor del vehículo.

Se advierte que el buen funcionamiento y la durabilidad del soporte pueden ser comprometidos por defectos en su instalación.

Debido a las diversas situaciones que se puedan presentar fuera del control del fabricante, TransArctic no garantiza el diseño, la durabilidad o el correcto funcionamiento de cualquier equipo inapropiadamente instalado por terceros.

Esta sobreentendido que el Instalador del montaje del compresor es estrictamente responsable de la seguridad y funcionamiento del equipo en el momento de la instalación.

Si tuviera algún problema o duda acerca de la instalación del soporte del compresor pongase en contacto inmediatamente con TransArctic al teléfono 1-877-COLD-AIR de modo que podamos mejorar nuestro producto.

Note la ubicación del medidor de tensión OEM

Instale el equipo

Controlar si hay interferencias.

Asegurese que el medidor de tensión mantenga la orientación justa.

Encienda el motor por lo menos 10 minutos con el sistema A/C enganchado para que la correa corra

Controle la orientación justa del medidor de tensión y ajuste a las condiciones requeridas del fabricante