

ISOMETRIC VIEW

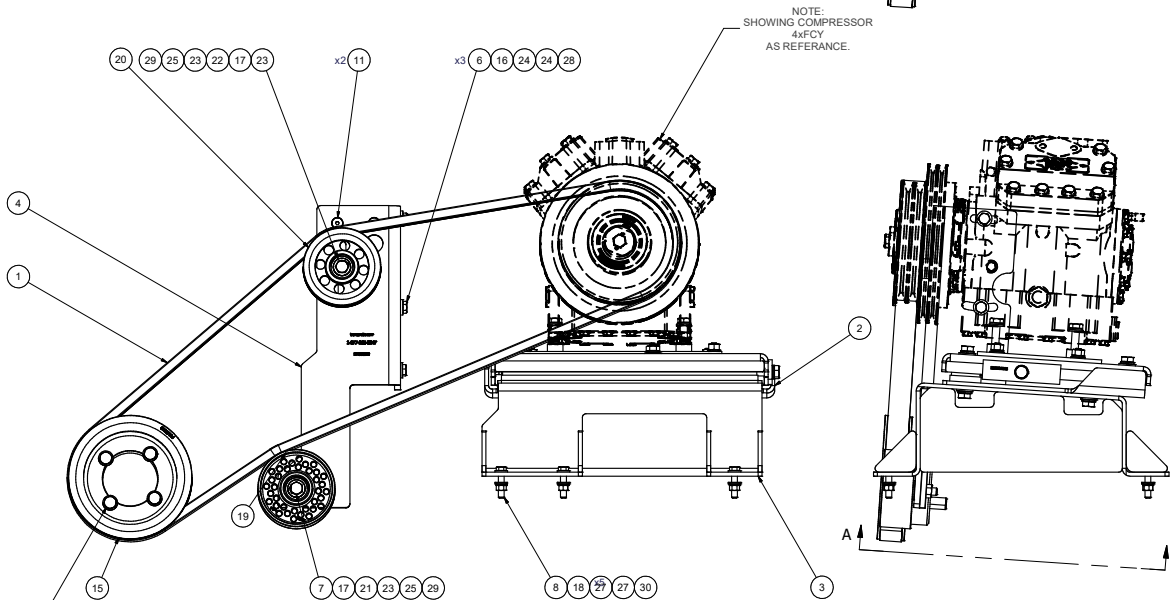

NOTE:
SHOWING COMPRESSOR
4xFCY
AS REFERENCE.

NOTE:
TORQUE TO: 66-73 FT-LB PLAIN & LUBRICATED W/ CLEAN ENGINE OIL (15W-40)
(HEXBOLT CAPSCREW M12 x 1.75 x 80mm @10.9 GRADE)
TIGHTEN IN TWO STEPS IN A CRIS-CROSS TIGHTENING SEQUENCE PATTERN.

NOTES:

- 1) USE SERVICABLE THREADLOCKER ON ALL FASTENERS TO ENGINE COMPONENTS AND TORQUE ALL BOLTS TO S.A.E. SPECIFICATIONS.
- 2) SEE "TRANSARCTIC A/C COMPRESSOR MOUNT INSTALLATION DISCLAIMER".

ITEM	QTY	U/M	PART NUMBER	DESCRIPTION
31	4	EACH	WLQ08000	WASHER, LOCK, 1/2", 8, PLT
30	5	EACH	WLQ06000	WASHER, LOCK, 3/8", 8, PLT
29	2	EACH	WLA12000	WASHER, LOCK, 12mm, 8.8, PLT
28	3	EACH	WLA10000	WASHER, LOCK, 10mm, 8.8, PLT
27	10	EACH	WFS06002	WASHER, FLAT, 3/8", L9, PLT
26	4	EACH	WFO08000	WASHER, FLAT, 1/2", 8, PLT
25	2	EACH	WFA12002	WASHER, FLAT, 12mm, HVY, 8.8, PLT
24	6	EACH	WFA10002	WASHER, FLAT, 10mm, HVY, 8.8, PLT
23	2	EACH	SLV17012	SLEEVE, PULLEY, 16.90 x 22.23 mm x12.19l
22	1	EACH	SCD21912	SPACER, COL, DRL, 21.9mm x 31.80 x12.3l
21	1	EACH	SCD16012	SPACER, COL, DRL, 16 mm x 31.80 x 12.0l
20	1	EACH	PUA05012	PULLEY, ASSY, IDLER, B/BX gr, 5" STL, PLT
19	1	EACH	PUA05001	PULLEY, ASSY, IDLER, B/S, 5", STL, PLT
18	5	EACH	NTQ06000	NUT, HEX, 3/8-16UNC, 8, PLT
17	2	EACH	NTA12000	NUT, HEX, 12 x 1.75, 8.8, PLT
16	3	EACH	NTA10000	NUT, HEX, 10 x 1.5, 8.8, PLT
15	1	EACH	KPC90009	KIT, PULLEY, ISL-G, 8.9L, 2B/X, '17
13	1	EACH	KCB3994	KIT, COMPRESSOR, PS, 4xFC, '13
12	4	EACH	CSF08101	CAPSCREW, FH, 1/2-20UNF x 1", ALLOY, PLT
11	2	EACH	CSF08031	CAPSCREW, FH, 8 x 1.25 x 30mm, 10.9, PLT
10	2	EACH	BTQ08151	BOLT, HEX, 1/2-20UNF x 1.50, 8, PLT
9	2	EACH	BTQ08125	BOLT, HEX, 1/2-13UNC x 1.25, 8, PLT
8	5	EACH	BTQ06175	BOLT, HEX, 3/8-16UNC, 1.75", 8, PLT
7	2	EACH	BTC12080	BOLT, HEX, 12 x 1.75 x 80mm, 10.9, PLT, FT
6	3	EACH	BTC10045	BOLT, HEX, 10 x 1.5 x 45mm, 10.9, PLT
5	1	EACH	BMC90026	BKT, ALIGNMT BAR, ADD-ON, ISL-G, HDX, '17
4	1	EACH	BMC90022	BKT, MAIN, IDLER, WELDMT, ISL, HDX, '16
3	1	EACH	BMC83129	BKT, WELDMT, MAIN BASE, ISL, HDX, '13
2	1	EACH	BMC83125	BKT, WELDMT, ADAPTER PL, ISL, HDX, '13
1	1	EACH	BEL32389	BELT, BANDED B gr, 2388mm (94")

BILL OF MATERIALS
TRANSARCTIC INC.

REV	ECN	DESCRIPTION	DATE	BY
0		RELEASED TO PRODUCTION	3/19/2019	JRR
1			3/13/2019	V.Jakowlew
2			3/13/2019	James Stewart
3			3/13/2019	Ron Ingram
4			3/13/2019	Dale Mason

DRAWN: jrodriguez 3/13/2019
 CHECKED: V.Jakowlew 3/13/2019
 TITLE: MT KIT, ISL-G, HDX, 4xFC, H.MOUNT, '16
 DWG NO: KMC43994
 SCALE: 1:4
 SHEET 1 OF 1

UNSPECIFIED TOLERANCES: ALL DIMS IN INCHES
 ONE DECIMAL PLACE (X1) .10 INCH
 TWO DECIMAL PLACE (X2) .01 INCH
 THREE DECIMAL PLACE (X3) .005 INCH
 FRACTIONAL (X1/16) 1/16 INCH



DRAWING UNIT OF MEASURE: MM (INCH)
 SCALE: 1:4