



**Mobile Climate Control**

T-299 Manual



# OPERATION AND SERVICE for SPLIT SYSTEMS

Generation 4 & 5

**T-299 Manual**

REV. 08/2012

## **SAFETY SUMMARY**

### **GENERAL SAFETY NOTICES**

The following general safety notices supplement the specific warnings and cautions appearing elsewhere in this manual. They are recommended precautions that must be understood and applied during operation, service, and maintenance of the equipment covered herein. The general safety notices are presented in the following three sections labeled: First Aid, Operating Precautions and Maintenance Precautions. A listing of the specific warnings and cautions appearing elsewhere in the manual follows the general safety notices.

### **FIRST AID**

An injury, no matter how slight, should never go unattended. Always obtain first aid or medical attention immediately.

### **OPERATING PRECAUTIONS**

Always wear protective eye wear (safety glasses or goggles).

Keep hands, clothing and tools clear of the evaporator and condenser fans.

No work should be performed on the system unless battery power is disconnected.

Always work in pairs. Never work on the equipment alone.

In case of severe vibration or unusual noise, stop the system and investigate.

### **MAINTENANCE PRECAUTIONS**

Familiarize yourself with the proper operation of any service equipment you will be using (voltmeter, amp probe, manifold gauges, etc.). Always read the owner's manual that is enclosed with the equipment

Always follow the manufacturers instructions for your recovery/recycling equipment. Failure to do so could cause personal injury or damage to your equipment. Never perform any maintenance or service on your equipment before consulting with authorized service personnel. Always unplug unit before attempting any maintenance. Removing internal fittings and filters can release pressurized refrigerant. Slowly release pressure and always wear appropriate safety wear.

Avoid breathing any refrigerant vapor, lubricant vapor, or mist. Exposure to these, particularly PAG oil mist, may irritate your eyes, nose, or throat.

Always use a DOT (Department of Transportation) approved cylinder for storing used and recycled refrigerant. Approved cylinders will be stamped DOT 4BW or DOT 4BA. MCC recommends a MACS (Mobile Air Conditioning Society) certification in Recovery/Recycling to gain more information on handling and using refrigerants.

Never attempt to apply heat or open flame to a refrigerant cylinder. High temperatures can raise the cylinder pressure to dangerous levels. MCC recommends using a heat blanket to increase the internal temperature of the refrigerant cylinder, greatly increasing the transfer of refrigerant to the bus air conditioning system.

Never use compressed air (shop-air) to leak-test or pressure test a R134a system. Under certain conditions, pressurized mixtures of R134a and air can be combustible. In addition, shop air will inject moisture into the system.

Always use mineral oil to lubricate “O” Rings, hoses, and fittings on R134a systems. PAG oils will absorb moisture and become very acidic and corrosive. Mineral oil will not absorb moisture and thus prevent corrosion. Always wear gloves when working with PAG and Ester lubricants to prevent irritation to your skin. R134a lubricants can also damage vehicles paint, plastic parts, engine drive belts and coolant hoses.

Beware of unannounced starting of the evaporator and condenser fans. Do not remove the evaporator cover or condenser fan guards without disconnecting the vehicle battery cable.

Be sure power is turned off before working on motors, controllers, and electrical control switches. Tag system controls and vehicle battery to prevent accidental energizing of the system.



Do not bypass any electrical safety devices, e.g. bridging an overload, or using any sort of jumper wires. Problems with the system should be diagnosed, and any necessary repairs performed, by qualified service personnel.

When performing any arc welding on the vehicle, disconnect the vehicle battery.

In case of electrical fire, extinguish with CO<sub>2</sub> (never use water). Disconnect vehicle battery power if possible.

## SPECIFIC WARNINGS

### **WARNING**

Beware of unannounced starting of the evaporator and condenser fans. The unit may cycle the fans and compressor unexpectedly as control requirements dictate.

### **WARNING**

Be sure to observe warnings listed in the safety summary in the front of this manual before performing maintenance on the air conditioning system

### **WARNING**

Never use air for leak testing. It has been determined that pressurized, air-rich mixtures of refrigerants and air can undergo combustion when exposed to an ignition source.

### **WARNING**

Do not use a nitrogen cylinder without a pressure regulator. Do not use oxygen in or near a refrigeration system or as an explosion may occur.

### **WARNING**

To prevent trapping liquid refrigerant in the manifold gauge set be sure set is brought to suction pressure before disconnecting.

### **WARNING**

There may be liquid refrigerant trapped behind the block valve. Slowly loosen the fitting and avoid contact with exposed skin or eyes.

### **WARNING**

The filter-drier may contain liquid refrigerant. Slowly open the fitting nuts and avoid contact with exposed skin or eyes.

### **CAUTION**

Unless there was a catastrophic failure, such as a blown or ruptured refrigerant hose, additional oil may not be needed.



**CAUTION**

Use only the exact oil specified by the compressor manufacturer. Use of oil other than that specified will void the compressor warranty.



# Table of Contents

**SAFETY SUMMARY** ..... **Safety -1**

    SPECIFIC WARNINGS ..... Safety -2

**SECTION 1** ..... **1-1**

**DESCRIPTION** ..... **1-1**

        1.1 INTRODUCTION ..... 1-1

        1.2 WHAT IS AIR CONDITIONING ..... 1-1

        1.3 MODEL AND SERIAL NUMBER TAGS ..... 1-1

        1.4 SYSTEM REQUIREMENTS LABEL ..... 1-5

        1.5 SYSTEM DESIGNATIONS ..... 1-5

        1.6 SYSTEM COMPONENTS ..... 1-5

        1.7 REFRIGERATION SYSTEM COMPONENT SPECIFICATIONS ..... 1-6

            a. EXPANSION/BLOCK VALVE: ..... 1-6

            b. PRESSURE SWITCHES: ..... 1-6

            c. FREEZE-UP THERMOSTAT: ..... 1-7

            d. RETURN AIR THERMOSTAT/SENSOR ..... 1-7

            e. EVAPORATOR MOTORS ..... 1-7

            f. CONDENSER MOTORS ..... 1-7

            g. COMPRESSORS ..... 1-7

        1.8 COOLING CYCLE ..... 1-7

        1.9 HEATING CYCLE (If Applicable) ..... 1-10

**SECTION 2** ..... **2-1**

**OPERATION** ..... **2-1**

        2.1 OPERATING INSTRUCTIONS ..... 2-1

        2.2 MANUAL CONTROLS ..... 2-1

            2.2.1 Driver's Control Panel ..... 2-1

            2.2.2 Fan Speed Switch (three speed or variable) ..... 2-1

            2.2.3 Thermostat Control ..... 2-1

            2.2.4 Electrical Control Panel ..... 2-1

        2.3 FLORIDA CONTROL (TEMPCON) ..... 2-2

            2.3.1 ON/OFF Function ..... 2-2

            2.3.2 Fan Speed Switch - 3 Speed ..... 2-2

            2.3.3 Adjusting Set Point (Interior Temperature Adjustment) ..... 2-2

        2.4 IN-LINE FUSE (FLORIDA CONTROL) ..... 2-2

        2.5 TOTAL CONTROL ..... 2-3

            2.5.1 Total Control Operation ..... 2-3

        2.6 GEN 4 - WITH TOTAL CONTROL, UNIT OPERATING INSTRUCTIONS ..... 2-5

        2.7 PRE-TRIP INSPECTION ..... 2-5

        2.8 SEQUENCE OF OPERATION ..... 2-5

            2.8.1 Three Position Switch Operation ..... 2-5



# Table of Contents

- 2.8.2 Variable Speed Control Operation ..... 2-6
- 2.8.3 Total Control - Gen 5 Operation ..... 2-6
- 2.8.4 Total Control - Gen 4 Operation ..... 2-6
- 2.8.5 Heat Option ..... 2-7
- 2.9 EnviroMATE Controller (Single Zone) ..... 2-8
  - 2.9.1 Controller Operation ..... 2-8
  - 2.9.2 Evaporator Fan Operation ..... 2-8
  - 2.9.3 Cooling Mode ..... 2-9
  - 2.9.4 Heating Mode (If equipped) ..... 2-9
  - 2.9.5 Sensors ..... 2-9
  - 2.9.6 Voltage ..... 2-9
  - 2.9.7 Schematics ..... 2-9
  - 2.9.8 Alarm Descriptions ..... 2-10
- 2.10 EnviroMATE Controller (Dual Zone) ..... 2-11
  - 2.10.1 Controller Operation ..... 2-11
  - 2.10.2 Evaporator Fan Operation (Automatic) ..... 2-12
  - 2.10.3 Evaporator Fan Operation (Manual) ..... 2-12
  - 2.10.4 Cooling Mode ..... 2-12
  - 2.10.5 Heating Mode (If equipped) ..... 2-13
  - 2.10.6 Sensors ..... 2-13
  - 2.10.7 Voltage ..... 2-13
  - 2.10.8 Schematics ..... 2-13
  - 2.10.9 Alarm Description (Dual Zone) ..... 2-14
- SECTION 3 ..... 3-1**
- TROUBLESHOOTING ..... 3-1**
- 3.1 . INSUFFICIENT OR NO COOLING ..... 3-1
  - 3.1.1 . Preliminary Checks ..... 3-1
  - 3.1.2 . Checking System Air Output ..... 3-1
  - 3.1.3 . Check The Sight Glass For Bubbles ..... 3-1
  - 3.1.4 . Compressor Amp Draw ..... 3-1
- 3.2 . SYSTEM WILL NOT COOL ..... 3-4
- 3.3 . SYSTEM RUNS BUT HAS INSUFFICIENT COOLING ..... 3-4
- SECTION 4 ..... 4-1**
- SERVICE ..... 4-1**
- 4.1 PREVENTATIVE MAINTENANCE SCHEDULE ..... 4-1
- 4.2 MAINTENANCE PROCEDURES ..... 4-2
- 4.3 INSTALLING MANIFOLD GAUGES ..... 4-2
- 4.4 REFRIGERANT RECOVERY ..... 4-5
- 4.5 REFRIGERANT LEAK CHECKING ..... 4-5
- 4.6 EVACUATION AND DEHYDRATION ..... 4-5
  - 4.6.1 General ..... 4-5



# Table of Contents

|                                      |   |            |
|--------------------------------------|---|------------|
| 4.6.2                                | Preparation .....   | 4-5        |
| 4.6.3                                | Procedure For Evacuation and Dehydrating System (Triple Evacuation) ..... | 4-6        |
| 4.7                                  | PROCEDURE FOR EVACUATION AND DEHYDRATING SYSTEM .....                     | 4-6        |
| 4.8                                  | ADDING REFRIGERANT TO A SYSTEM .....                                      | 4-6        |
| 4.8.1                                | Checking Refrigerant Charge .....   | 4-6        |
| 4.8.2                                | Adding Full Charge .....  | 4-6        |
| 4.8.3                                | Adding Partial Charge .....   | 4-6        |
| 4.9                                  | COMPRESSOR(S) .....   | 4-7        |
| 4.9.1                                | .. Evaporator Tie-In .....  | 4-9        |
| 4.10                                 | TORQUE SPECIFICATIONS - REFRIGERANT FITTINGS .....                        | 4-11       |
| 4.11                                 | TORQUE SPECIFICATIONS - BOLTS .....                                       | 4-11       |
| 4.11.1                               | Electrical Control Panel - Torque Values .....                            | 4-11       |
| 4.12                                 | DRIVE BELT INSTALLATION .....   | 4-12       |
| 4.12.1                               | Introduction .....  | 4-12       |
| 4.12.2                               | Belt Clearance .....  | 4-12       |
| 4.12.3                               | Pulley Alignment .....  | 4-12       |
| 4.12.4                               | Drive Belt Tension Guidelines .....                                       | 4-13       |
| 4.12.5                               | Measuring Methods for Belt Tension .....                                  | 4-14       |
| 4.13                                 | RETURN AIR FILTER .....   | 4-14       |
| 4.13.1                               | GEN 4 (EXCEL) Series .....  | 4-14       |
| 4.13.2                               | GEN 5 Series .....  | 4-14       |
| 4.14                                 | EVAPORATOR BLOWER AND/OR MOTOR ASSEMBLY .....                             | 4-15       |
| 4.14.1                               | GEN 4 Series .....  | 4-15       |
| 4.14.2                               | GEN 5 Series .....  | 4-15       |
| 4.15                                 | RESISTORS .....   | 4-15       |
| 4.15.1                               | GEN 4 Series (Excel) .....  | 4-15       |
| 4.15.2                               | GEN 5 Series .....  | 4-15       |
| 4.16                                 | CONDENSER FAN ASSEMBLY .....  | 4-16       |
| 4.17                                 | REPLACING THERMOSTATIC BLOCK VALVE .....                                  | 4-16       |
| 4.18                                 | CHECKING AND REPLACING HIGH PRESSURE SWITCH .....                         | 4-16       |
| 4.18.1                               | Replacing High or Low Pressure Switch .....                               | 4-16       |
| 4.18.2                               | Checking High Pressure Switch .....                                       | 4-16       |
| 4.19                                 | MOISTURE INDICATOR (SYSTEM) .....   | 4-17       |
| 4.20                                 | FILTER-DRIER OR RECEIVER-DRIER .....                                      | 4-17       |
| <b>SECTION 5</b>                     | .....   | <b>5-1</b> |
| <b>ELECTRICAL SCHEMATIC DIAGRAMS</b> | .....   | <b>5-1</b> |
| 5.1                                  | INTRODUCTION .....  | 5-1        |

## List of Tables

|  |      |
|--|------|
| Table 1-1 Additional Support Manuals .....                                   | 1-1  |
| Table 3-1 Evaporator Current Draw (GEN 4) .....                              | 3-2  |
| Table 3-2 Evaporator Current Draw (GEN 5) .....                              | 3-3  |
| Table 3-3 Condenser Current Draw (GEN 5) .....                               | 3-3  |
| Table 3-4 GENERAL SYSTEM TROUBLESHOOTING PROCEDURES .....                    | 3-4  |
| Table 3-4 GENERAL SYSTEM TROUBLESHOOTING PROCEDURES - Continued .....        | 3-5  |
| Table 4-1 Split System Refrigerant And Oil Charging Table - Thru GEN 4 ..... | 4-8  |
| Table 4-2 SPLIT SYSTEM REFRIGERANT AND OIL CHARGING TABLE (GEN-5) .....      | 4-8  |
| Table 4-3 SPLIT-SYSTEM GEN-5 WITH MICRO-CHANNEL CONDENSER .....              | 4-8  |
| Table 4-4 Compressor Oil Type & Part Numbers .....                           | 4-9  |
| Table 4-5 Mobile Climate Control SYSTEM PERFORMANCE CHART .....              | 4-10 |
| Table 4-6 STANDARD TORQUE REQUIREMENTS .....                                 | 4-11 |
| Table 4-7 Metric Torque Specs .....  | 4-11 |
| Table 4-8 U.S. Torque Specs .....  | 4-11 |
| Table 4-9 Belt Tension Guide .....   | 4-14 |
| Table 4-10 R-134a Temperature - Pressure Chart .....                         | 4-19 |

## List of Figures

|  |      |
|--|------|
| Figure 1-1 Condenser Model CM2/3 - Serial Number Location .....                          | 1-2  |
| Figure 1-2 GEN 4 Evaporator Model - Serial Number Location .....                         | 1-2  |
| Figure 1-3 GEN 5 Evaporator Model (All) - Serial Number Location .....                   | 1-2  |
| Figure 1-4 GEN 4, IW-2 & IW-7 - Serial Number Location .....                             | 1-3  |
| Figure 1-5 GEN 4, IW-1 - Serial Number Location .....                                    | 1-3  |
| Figure 1-6 CM-7/11 Rooftop Condensers (No Longer Offered) - Serial Number Location ..... | 1-4  |
| Figure 1-7 KR-2/KR-3 Rooftop Condensers - Serial Number/PID Location .....               | 1-4  |
| Figure 1-8 System Requirements Label .....   | 1-4  |
| Figure 1-9 Component Location Diagram .....  | 1-6  |
| Figure 1-10 Air Conditioning Refrigerant Flow Diagram - Small Split System .....         | 1-9  |
| Figure 1-11 Heating System Flow Diagram (Typical) .....                                  | 1-10 |
| Figure 2-1 Drivers Control Panel .....   | 2-1  |
| Figure 2-2 Electrical Panel (Typical) .....  | 2-1  |
| Figure 2-3 Switch Assembly (TEMPCON) .....   | 2-2  |
| Figure 2-4 In-Line Fuse & Holder (3 Amp) .....   | 2-2  |
| Figure 2-5 Total Control Key Pad/Display .....   | 2-3  |
| Figure 2-6 Null Band .....   | 2-4  |
| Figure 2-7 Total Control Electrical Control Panel (Typical) .....                        | 2-4  |
| Figure 2-8 EnviroMATE Control Panel .....  | 2-8  |

## List of Figures





Figure 2-9 EnviroMATE Alarms (Single Zone) ..... 2-10

Figure 2-10 EnviroMATE Control Panel ..... 2-11

Figure 2-11 EnviroMATE Alarms (Dual Zone) ..... 2-14

Figure 4-1 Manifold Gauge Set ..... 4-2

Figure 4-2 Refrigerant Service Connections (Split Systems) ..... 4-4

Figure 4-1 Micro-Channel Style Condenser Assembly ..... 4-9

Figure 4-3 Metric Bolt Markings ..... 4-11

Figure 4-4 U.S. Bolt Markings ..... 4-11

Figure 4-5 Belt Clearance Requirements ..... 4-12

Figure 4-6 Belt Misalignment ..... 4-13

Figure 4-7 Straight-Edge Application ..... 4-13

Figure 4-8 GEN 4 Series Resistor Assembly ..... 4-15

Figure 4-9. Checking High Pressure Switch ..... 4-17

Figure 4-10 Filter Drier ..... 4-18

Figure 4-11 Receiver-Drier ..... 4-18

Figure 5-1 Electrical Schematic Diagram - Symbols ..... 5-1

Figure 5-2 Legend - Electrical Schematic Diagrams ..... 5-2

Figure 5-3 GEN 4 System Schematic - EM-1 With CM-2/3 ..... 5-3

Figure 5-4 GEN 4 System Schematic - EM-1 With CM-2/3 - Tie-In ..... 5-4

Figure 5-5 GEN 4 System Schematic - EM-3 With (2) CM-3 Condensers & (2) Compressors ..... 5-6

Figure 5-6 GEN 5 Evaporator (With Variable Speed Control) Schematic ..... 5-6

Figure 5-7 GEN 5 System Schematic With Total Control ..... 5-7

Figure 5-8 GEN 4 EM-3 With (2) CM-3 With Total Control - System Schematic ..... 5-8

Figure 5-9 GEN 4 Series With Total Control ..... 5-9

Figure 5-10 Gen V with EnviroMATE Controller (Single Zone) ..... 5-10

Figure 5-11 Gen V with EnviroMATE Controller (Dual Zone, 2 Evaps., 2 condensers, 2 Comps.) . 5-11

Figure 5-12 Gen V with EnviroMATE Controller (Dual Zone, 3 Evaps., 2 condensers, 2 Comps.) . 5-12



## SECTION 1

### DESCRIPTION

#### 1.1 INTRODUCTION

This manual contains Operating, Service, and Maintenance Instructions for Gen 4 and Gen 5 Split System Air Conditioning and Heating equipment furnished by Mobile Climate Control. Additional support manuals are listed in Table 1-1.

A Split System normally includes an Evaporator(s), a Condenser(s) a Compressor(s) and interconnecting refrigerant hoses, fittings, and electrical harnesses and controls. A listing of the evaporator and condenser models, along with specific data for each, is provided in the component data that follows.

Specific systems may vary, this manual does not cover all combinations, variations, and applications, it does set up standards from which processes can be measured. Contact Mobile Climate Control Technical Service Hot-Line for additional assistance (800-450-2211).

#### 1.2 WHAT IS AIR CONDITIONING

Air Conditioning is the cooling, heating, dehumidification, and filtration of the air located within the passenger compartment of a vehicle.

#### 1.3 MODEL AND SERIAL NUMBER TAGS

In order to identify the air conditioning components you have, you will need to know the model number and serial number. All Mobile Climate Control evaporators, condensers and compressors have a model/serial number tag or PID decal located on the assembly. See Figure 1-1 for all skirt mounted

condenser data tag locations, Figure 1-2 for GEN 4 evaporator data tag location, Figure 1-3 for GEN 5 evaporator data tag locations, Figure 1-4 & Figure 1-5 for In-Wall data tag locations, Figure 1-7 for KR-2 & KR-3 PID locations and Figure 1-6 for the CM-7 & CM-11 rooftop condensers data tag location. The CM-7 and CM-11 rooftop condensers are no longer available from MCC.

#### NOTE

The EM-9 evaporator data tag is located on the side of the evaporator assembly, not between the blower assemblies (See Figure 1-2).

Knowing these locations and the information on the data tags will aid you in identifying the correct service procedures.

#### 1.3.1 PID Data Tag (Decal)

All KR2, KR3 & KR4 Rooftop Condensers have PID Decals instead of the standard Model/Serial tag. These tags will list the following:

- a. System Model No. (Example - 68KR4-101-2)
- b. Serial No.
- c. P.I.D. (Example - KR4C00032)
- d. Refrigerant (Example - R134a)
- e. Voltage (Example - 13.5 VDC)
- f. Amps (Example - 25A)
- g. Unit Weight (Example - 186 lbs.)

Table 1-1 Additional Support Manuals

| MANUAL NUMBER | EQUIPMENT COVERED | TYPE OF MANUAL          |
|---------------|-------------------|-------------------------|
| T-299PL       | Split Systems     | Parts List              |
| T-311         | Split Systems     | Installation Procedures |



**Figure 1-1 Condenser Model CM2/3 - Serial Number Location**

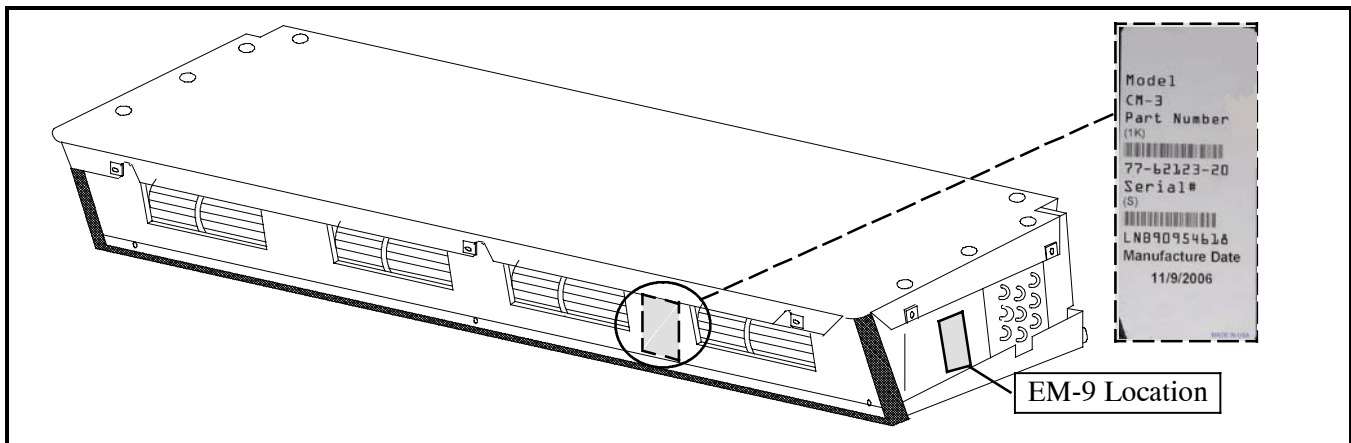

**Figure 1-2 GEN 4 Evaporator Model - Serial Number Location**



**Figure 1-3 GEN 5 Evaporator Model (All) - Serial Number Location**

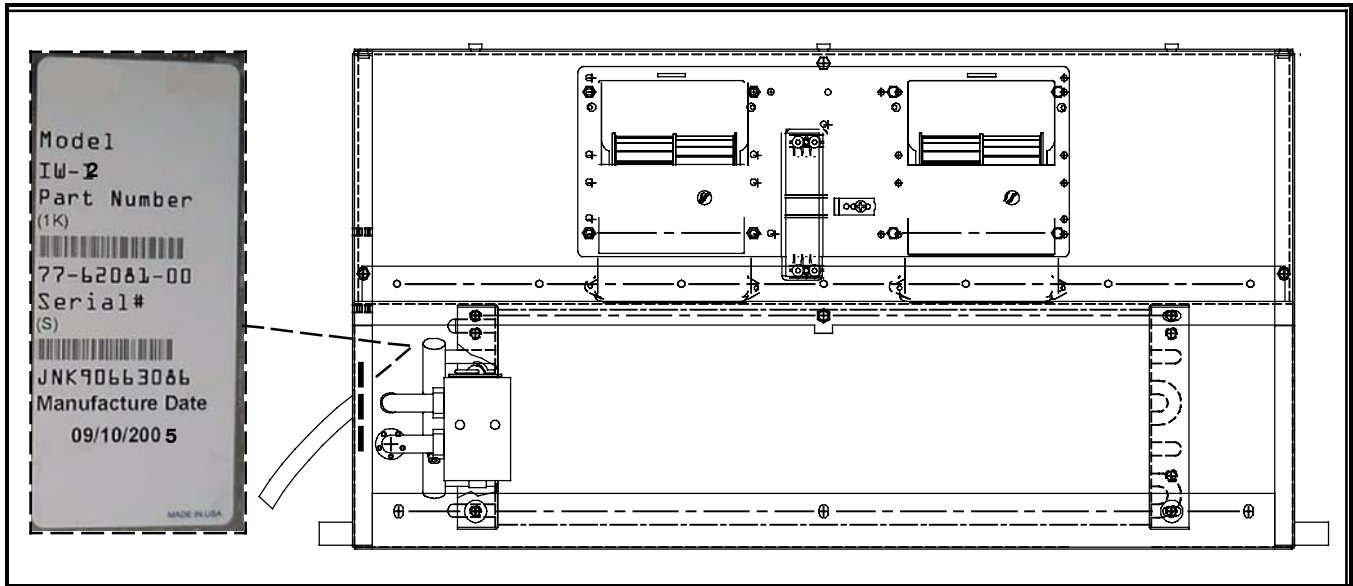

Figure 1-4 GEN 4, IW-2 & IW-7 - Serial Number Location



Figure 1-5 GEN 4, IW-1 - Serial Number Location



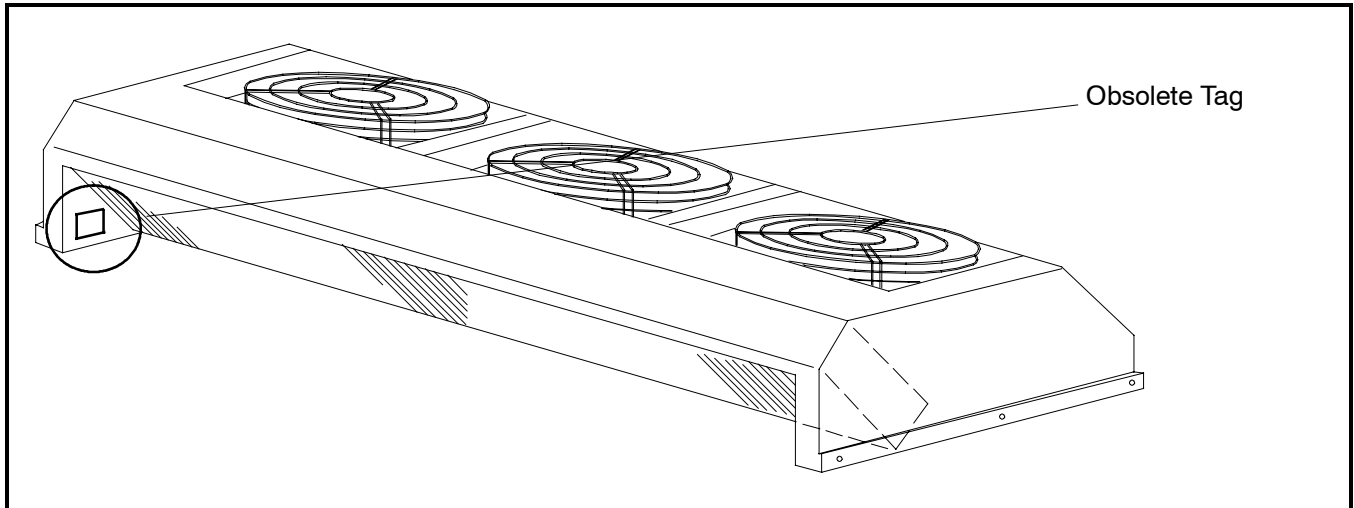

Figure 1-6 CM-7/11 Rooftop Condensers (No Longer Offered) - Serial Number Location

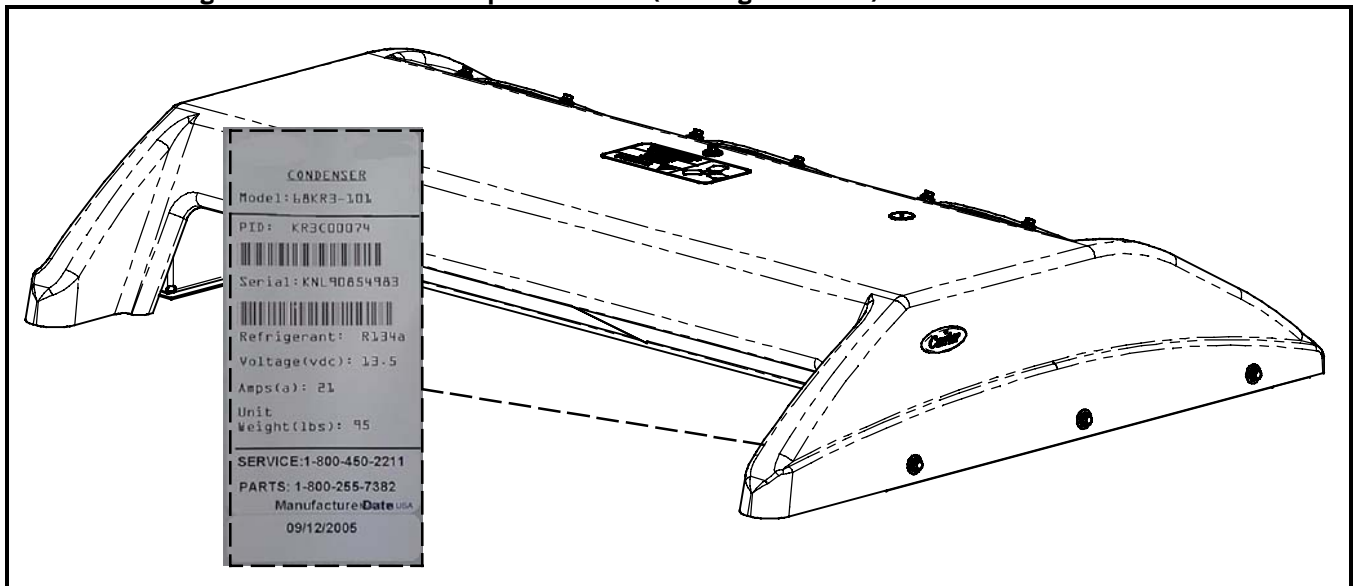

Figure 1-7 KR-2/KR-3 Rooftop Condensers - Serial Number/PID Location

|                                   |                                    |                                    |
|-----------------------------------|------------------------------------|------------------------------------|
| AIR CONDITIONING SYSTEM           |                                    | SERVICE 1-800-450-2211             |
|                                   |                                    | PARTS 1-800-255-7382               |
| SER. NOS.                         | COMP. #1 <u>C090833</u>            | #2 <u>C090936</u>                  |
| EVAP. #1 <u>51-004120</u>         | #2 <u>51-004148</u>                | #3 <u>          </u>               |
| COND. #1 <u>107-080187</u>        | #2 <u>07-080188</u>                |                                    |
| REFRIGERANT TYPE R- <u>134a</u>   | #1-QTY. <u>5</u> LBS. <u>5</u> OZ. | #2-QTY. <u>5</u> LBS. <u>9</u> OZ. |
| OIL TYPE <u>PAG-SANDEN</u>        | #1-QTY. <u>11</u> OZ.              | #2-QTY. <u>11.8</u> OZ.            |
| BELT NO. CURB SIDE <u>17455</u>   | MOUNT KIT NO.                      |                                    |
| BELT NO. ROAD SIDE <u>601-227</u> | <u>050-169</u>                     |                                    |
| INSTALLER <u>THE BUS CO.</u>      | DATE <u>01-22-07</u>               |                                    |

Figure 1-8 System Requirements Label



## 1.4 SYSTEM REQUIREMENTS LABEL

The system requirements label is conveniently located within the vehicle's engine compartment. This label, when properly completed by the installer, will give the servicing technician the refrigerant and oil charge(s), evaporator(s), condenser(s), and compressor(s) serial numbers, the drive belt(s) number, mount kit number, the date of installation and the installer (See Figure 1-8).

## 1.5 SYSTEM DESIGNATIONS

**Tie-In System** - Is an MCC evaporator and condenser connected to an existing OEM compressor and dash evaporator. The OEM radiator condenser is normally removed.

### NOTE

You may encounter installations where the OEM radiator style condenser is used as the Tie-In condenser. Call Mobile Climate Control Technical Service Hot-Line (800-450-2211) for assistance, as this is not a recommended Mobile Climate Control Air Conditioning application.

**Max System** - An MCC system installed along with an existing OEM system. The systems operate independent of each other.

**Stand-Alone (Standard) System** - All MCC components installed on a vehicle. These can be either single or dual compressor systems.

**IW (In-Wall) System** - An MCC evaporator installed in the front and/or rear of the vehicle. This type evaporator is installed between the inside & outside walls of the vehicle.

## 1.6 SYSTEM COMPONENTS

**Return Air Thermostat/Sensor** - The system may be supplied with a thermostat or thermistor. Both of these devices are temperature sensitive components which when activated, signals the Electro-Magnetic Clutch to engage/disengage. The return air thermostat is normally located in the driver's control panel while the return air thermistor is normally located in the evaporator assembly.

**Electro-Magnetic clutch** - The Electro-Magnetic clutch controls the operation of the compressor. When engaged, the compressor circulates refrigerant and provides cooling (See Figure 1-9).

**Expansion/Block Valve** - Meters the refrigerant flow into the evaporator coil. The majority of the Gen 4 (Excel) and all Gen 5 systems use a nonadjustable block valve with an 8° F superheat setting, which is preset at the factory. If you feel there is a problem with the block valve, do not attempt to adjust the valve, replace it.

### NOTE

In the event you encounter a Gen 1, Gen 2, or Gen 3 system with an externally equalized expansion valve and/or a system with refrigerant R12, contact MCC's Technical Service Hot Line (800-450-2211) for assistance.

**Evaporator** - The evaporator is located in the interior of the vehicle. Its primary function is to transfer heat contained in the passenger compartment air, into the refrigerant, which is circulated by the compressor, through the evaporator coil. During this process the air is also filtered and dehumidified.

**Resistor** - Resistors are used to control the speeds of the permanent magnet evaporator blower motors.

**Compressor** - The compressor is a belt driven, high-pressure pump, which circulates the refrigerant through the evaporator and condenser. The operation of the compressor is controlled by the Electro-Magnetic clutch.

**Condenser** - The condenser is normally located in the skirt or on the roof of the vehicle. Its primary function is to reject heat, which was transferred to the refrigerant by the evaporator from the passenger compartment of the vehicle.

**Filter-Dryer** - The filter-dryer removes moisture and particulate matter from the refrigerant.

**Receiver-Dryer** - The receiver-dryer removes moisture and particulate matter from the refrigerant. The receiver-drier also stores a small amount of liquid refrigerant.

**Pressure Switches** - The systems use high and low pressure switches wired in series to control the power circuit of the compressor clutch relay. If either pressure switch opens, interrupting the circuit to the clutch relay, the operation of the compressor will stop. When conditions return to normal the switch will automatically reset and the compressor will resume operating. The switches are non-adjustable.



**Freeze-Up Thermostat** - Mobile Climate Control systems use a freeze thermostat (freeze stat) wired in series with the system pressure switches to control the operation of the compressor clutch. Freeze-up thermostats are used to prevent ice from forming on the evaporator coil, which is an indication that liquid refrigerant is getting back to the compressor.

**Refrigerant** - A refrigerant is a material that is used

to move heat from the passenger compartment to the outside air. It is a substance that gives up heat by condensing at high temperature and pressures and absorbs heat by evaporating at low temperatures and pressures. The heat transfer properties exhibited when refrigerant changes state is the foundation of the refrigerant cycle. Most MCC systems use R134a.

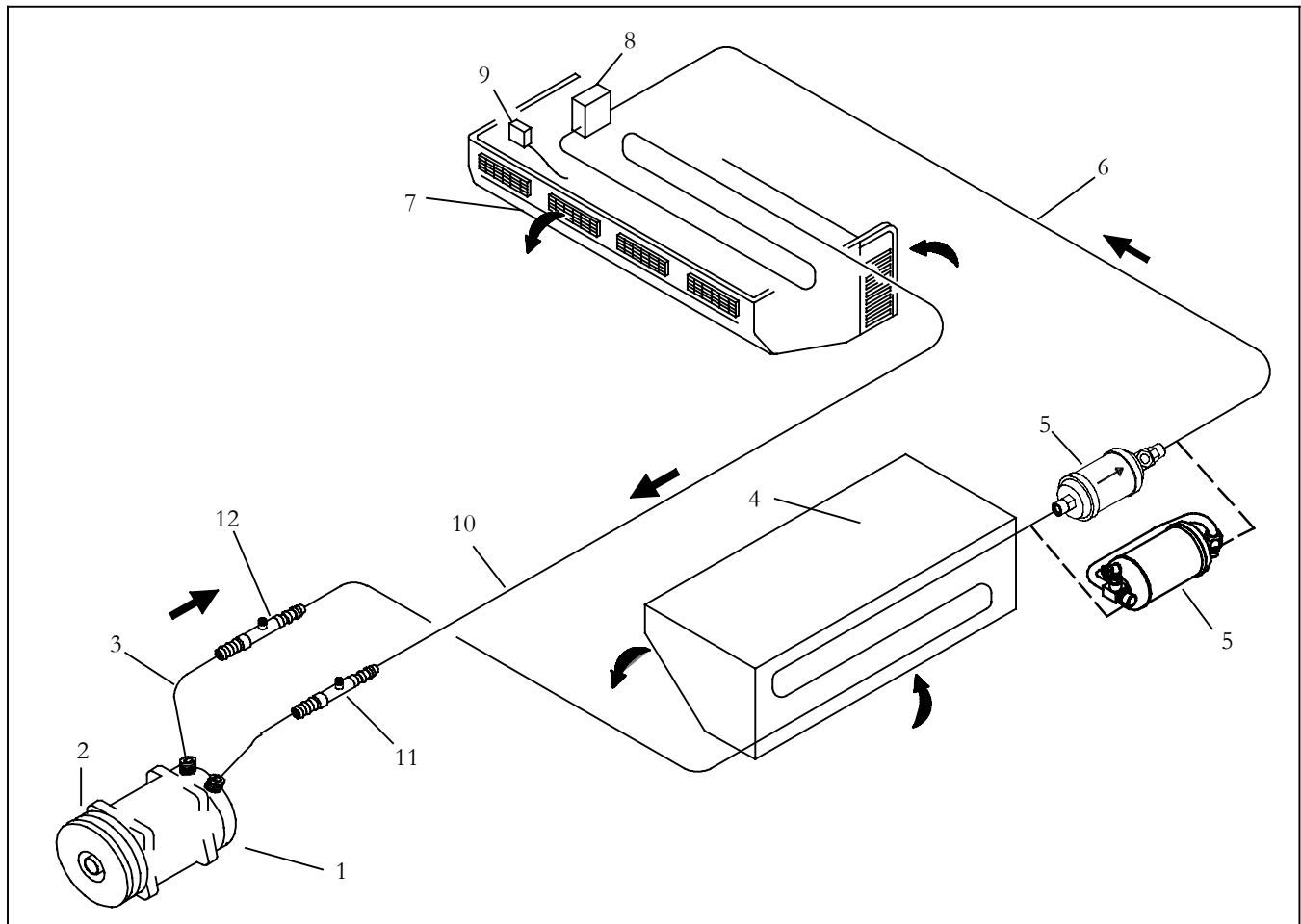

- |   |                                |    |   |
|---|--------------------------------|----|---|
| 1 | Compressor                     | 7  | Evaporator                              |
| 2 | Electro-Magnetic Clutch        | 8  | Block Valve (TXV)                       |
| 3 | Discharge Line                 | 9  | Freeze stat-(Coil freeze-up thermostat) |
| 4 | Condenser                      | 10 | Suction Line                            |
| 5 | Filter-Dryer or Receiver-Drier | 11 | Suction Access Valve                    |
| 6 | Liquid Line                    | 12 | Discharge Access Valve                  |

Figure 1-9 Component Location Diagram

**1.7 REFRIGERATION SYSTEM COMPONENT SPECIFICATIONS**

**a. EXPANSION/BLOCK VALVE:**

Superheat Setting: 8° F

**b. PRESSURE SWITCHES:**

High Pressure Switch: Normally closed, open on pressure rise.

Cut-out at 400 psig - Cut-in at 300 psig.(± 5%)

Low Pressure Switch: Normally closed, open on pressure drop.

Cut-in at 25 psig. - Cut-out at 10 psig (± 5%)



**c. FREEZE-UP THERMOSTAT:**

GEN 4 Series Freeze-Up Thermostat: Cut-out at 26° F, ± 1.5° F. Cut-in at 34° F, ± 1.5° F. Pre-set at factory (Adjustable). Turn counterclockwise to end- then 1/4 turn clockwise for original factory setting.

GEN 5 Series Freeze-Up Thermostat: Cut-out at 30.5° F, ± 1.5° F. Cut-in at 45° F, ± 1.5° F. Pre-set at the factory (Non-adjustable).

**d. RETURN AIR THERMOSTAT/SENSOR**

Return Air Thermostat: Adjustable range from 55° F to 85° F. Normal remote (drivers location) setting is 55° F with a ± 5° F differential.

Return Air Sensor (Total Control): Temperature range 60° F to 80° F.

**e. EVAPORATOR MOTORS**

**Gen 4 Series:** Double shafted 12 VDC (13.5 VDC Nominal), permanent magnet, motor/blower assemblies.

Full Load Amps: Refer to Table 3-1  
Volts DC Maximum: 15.1 VDC  
Volts DC Minimum: 10.8 VDC  
RPM: 2600 @ zero static

**Gen 5 Series:** Single shafted 12 VDC continuous duty motors.

Full Load Amps: 30 Amps @ 2900 RPM @ 12.5 VDC  
Locked Rotor Amps: 80 Amps  
Volts DC Maximum: 16 VDC  
Volts DC Minimum: 4 VDC

**f. CONDENSER MOTORS**

**Rooftop:**

**CM-7 and CM-11:** Single shafted 12 VDC (12.5 Nominal) continuous duty motors (barrel type) to be used with Rooftop Condensers.

Full Load Amps: 30 Amps @ 2900 RPM @ 12.5 VDC  
Locked Rotor Amps: 80 Amps  
Volts DC Maximum: 16 VDC  
Volts DC Minimum: 4 VDC

**KR-2 and KR-3:** Fan-Motor Assembly. Single shafted 12 VDC (12.5 Nominal) continuous duty motors.

Full Load Amps: 7 Amps @ 2100 RPM @ 12.5 VDC  
Locked Rotor Amps: 40 Amps  
Volts DC Maximum: 13.5 VDC  
Volts DC Minimum: 5 VDC

**KR-4:** Single shafted, permanent magnet, 12 VDC (12.5 Nominal) continuous duty, single speed motors.

Full Load Amps: 7 Amps @ 1900 RPM @ 12.5 VDC  
Locked Rotor Amps: 30 Amps  
Volts DC Maximum: 16 VDC  
Volts DC Minimum: 4 VDC

**Skirt Mounted:** Permanent magnetic, single speed motor (12VDC nominal) and fan combination (pancake style) 5 blades.

Full Load Amps: 7 Amps @ 2100 RPM @ 12.5 VDC  
Locked Rotor Amps: 40 Amps @ 13.5VDC  
Volts DC Maximum: 13.5 VDC  
Volts DC Minimum: 5 VDC

**Skirt Mounted ("Vector" Fan):** Permanent magnetic, single speed motor (12VDC nominal) and fan combination (pancake style) 10 blades.

Full Load Amps: 6.8 Amps @ 2350 RPM @ 12.5 VDC  
Locked Rotor Amps: 25.4 Amps @ 13.5VDC  
Volts DC Maximum: 13.5 VDC  
Volts DC Minimum: 5 VDC

**g. COMPRESSORS**

Mobile Climate Control uses a variety of compressors properly sized and suited for split system applications. Their cubic inch displacement (c.i.d.) ranges from a 10 cubic inch TM-16 to the 19.1 cubic inch TM-31. Applications include rear and front engine mounted. Compressor Clutch coils typically draw 2 to 3 Amps. A compressor must always be replaced with a compressor of the same style and capacity.

**1.8 COOLING CYCLE**

The unit operates as a vapor compression system using R-134a as the refrigerant (see Figure 1-10 ). The compressor raises the pressure and the temperature of the refrigerant vapor and forces it thru the discharge lines into the condenser tubes. The condenser fan circulates surrounding air (which is at a temperature lower than the refrigerant) over the outside of the condenser tubes. Heat transfer is established from the refrigerant (inside the tubes) to the condenser air (flowing over the tubes). The condenser tubes have fins designed to improve the transfer of heat from the refrigerant gas to the air; this removal of heat causes the refrigerant to liquefy, thus liquid refrigerant leaves the condenser and flows to the filter-drier. The filter-drier contains an absorbent that keeps the refrigerant clean and dry.





### NOTE

The new style micro-channel condensers are fitted with receiver-driers instead of filter-driers. The receiver-drier performs the same function as a filter-drier and it also stores liquid refrigerant.

From the filter-drier/receiver-drier, the liquid refrigerant then flows to the block type expansion valve. The expansion valve reduces pressure and temperature of the liquid and meters the flow of liquid refrigerant to the evaporator to obtain maximum use of the evaporator heat transfer surface.

The low pressure, low temperature liquid that flows into the evaporator tubes is colder than the air that is circulated over the evaporator tubes by the evaporator fans. Heat transfer is established from the evaporator air (flowing over the tubes) to the refrigerant (flowing inside the tubes). The evaporator tubes have fins to increase heat transfer from the air to the refrigerant; therefore the cooler air is circulated to the interior of the vehicle.

The transfer of heat from the air to the low temperature liquid refrigerant in the evaporator causes the liquid to vaporize. This low temperature, low pressure vapor refrigerant then continues through the suction line and returns to the compressor where the cycle repeats.

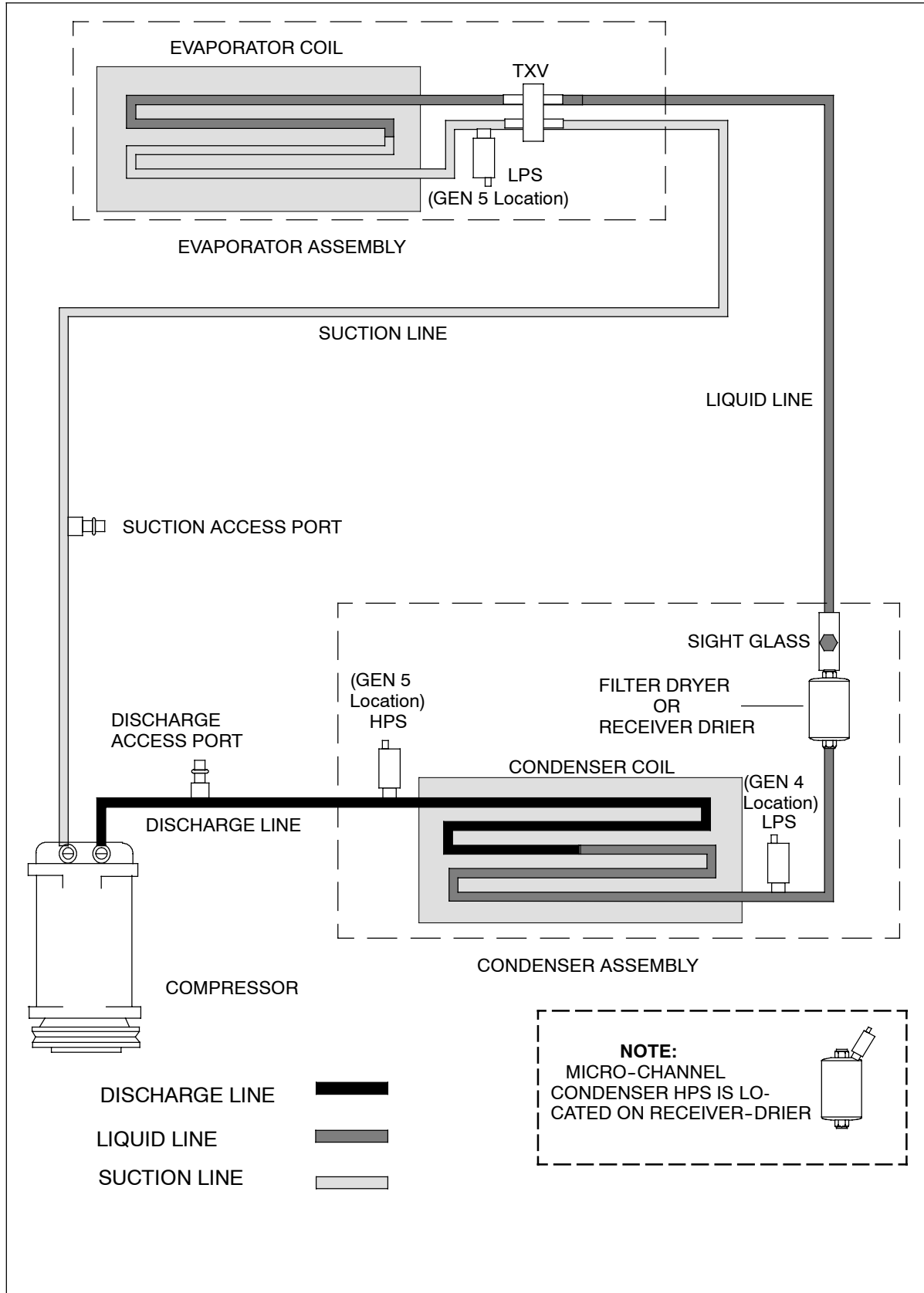
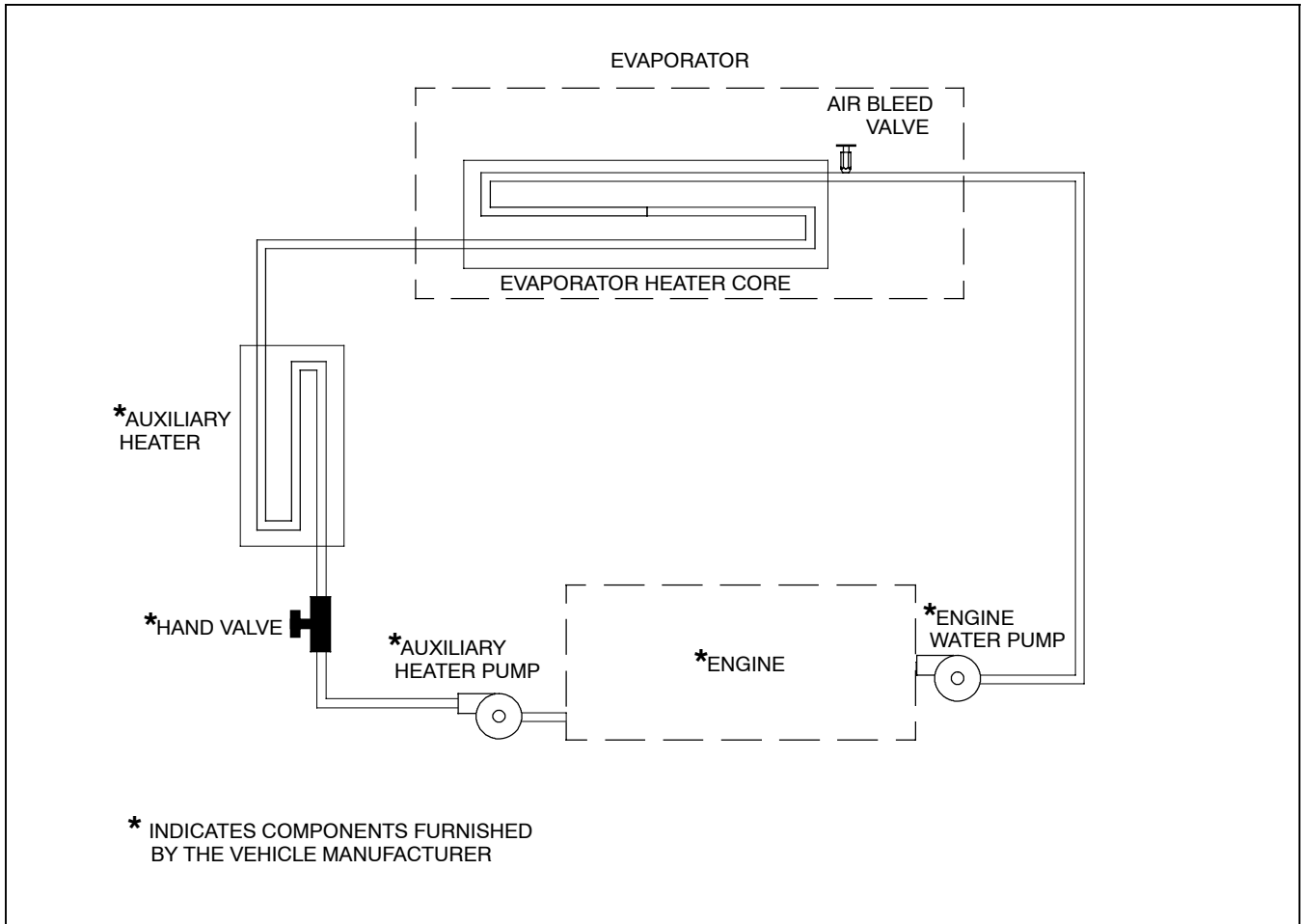

Figure 1-10 Air Conditioning Refrigerant Flow Diagram - Small Split System

### 1.9 HEATING CYCLE (If Applicable)

The optional heating circuit component furnished by Mobile Climate Control is the side or rear mounted evaporator heater core. Components furnished by the vehicle manufacturer include coolant (glycol solution), pumps, and a hot water shut-off valve (See Figure 1-11).

Engine coolant is circulated through the heating circuit by the engine and/or auxiliary water pump. When the heat valve is opened, engine coolant flows through the heater coil. Heat is transferred from the glycol flowing in the tubes to the air flowing over the tubes. The heater tubes have aluminum fins to increase heat transfer from the glycol to the air.



**Figure 1-11 Heating System Flow Diagram (Typical)**



## SECTION 2 OPERATION

### 2.1 OPERATING INSTRUCTIONS

Before attempting to operate the system, power must be available from the vehicle battery. If the engine is not running, start the engine.

The system may be supplied with Manual Controls (see Figure 2-1 & Figure 2-3) or the Mobile Climate Control Total Control (see Figure 2-5).

Refer to the Sections 2.2 & 2.3 for manual control operating instructions or Section 2.5 for Total Control operating instructions.

### 2.2 MANUAL CONTROLS

Mobile Climate Control systems are manually operated by a Drivers Control Panel (See Figure 2-1) wired into an Electrical Control Panel (See Figure 2-2).

#### 2.2.1 Driver's Control Panel

The Drivers Control Panel (See Figure 2-1), consists of an evaporator fan speed switch (three speed or variable) and an adjustable thermostat. The drivers control panel is normally located within easy reach of the driver. On larger bus applications there could be two (2) separate air conditioning system driver control panels. One for each system.

There will be some applications where the switch mounting plate, thermostat and fan speed switch are mounted in the drivers area without the control panel housing.

On some applications the vehicle manufacturer (OEM) will supply different type controls for the air conditioning system. Refer to OEM technical manual for operating instructions.

#### 2.2.2 Fan Speed Switch (three speed or variable)

**Three Speed** - The standard fan speed switch has four settings, Off (0), Low (1), Medium (2), and High (3) speed operation. This switch controls the operation of the system and the evaporator blower(s) by energizing the appropriate circuits and relays located on the electrical control panel. See Figure 2-2.

**Variable Speed** - Certain applications may be fitted with a variable speed control switch instead of the standard three speed switch. This switch controls the speed of the evaporator motors by varying the supply voltage.

#### 2.2.3 Thermostat Control

The thermostat controls the temperature within the passenger compartment by switching system components on and off.

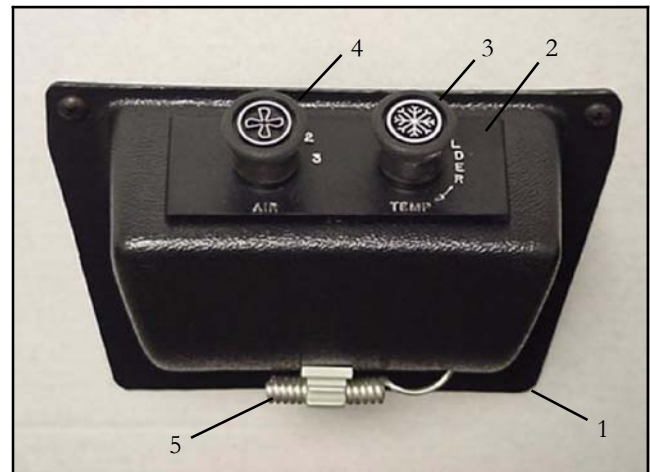

- 1 Control Panel Housing
- 2 Nameplate (Switch Mounting)
- 3 Thermostat Control Switch
- 4 Fan Speed Switch (3 Speed or Variable)
- 5 Ambient Air Sensor (Thermostat)

Figure 2-1 Drivers Control Panel

#### 2.2.4 Electrical Control Panel

The electrical control panel contains relays and circuit breakers used for system control.

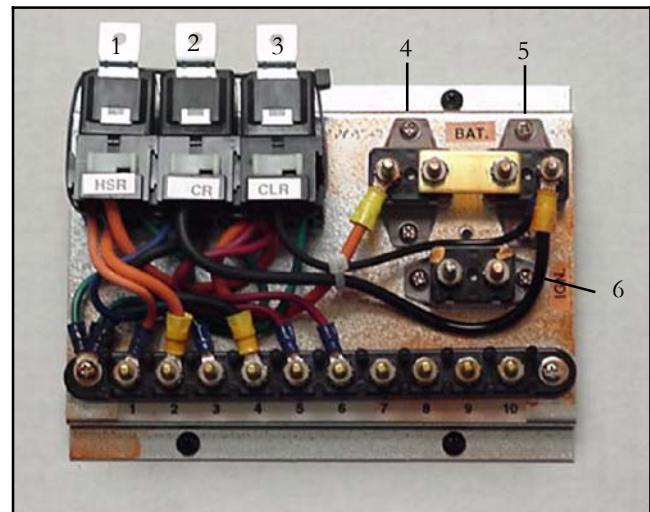

- 1 High Speed Relay
- 2 Condenser Relay
- 3 Compressor Clutch Relay
- 4 Circuit Breaker (HSR)
- 5 Circuit Breaker (CR)
- 6 Circuit Breaker (Ignition)

Figure 2-2 Electrical Panel (Typical)



### 2.3 FLORIDA CONTROL (TEMPCON)

This controller is normally used in school buses located within the state of Florida, but not limited to that area (See Figure 2-3). This controller is wired to an electrical control board.

The controller consists of:

- a. ON/OFF Switch
- b. Fan Speed Switch
- c. Potentiometer
- d. In-Line Fuse (Behind Controller)

#### 2.3.1 ON/OFF Function

Power is supplied to the controller, through an in-line fuse (see Figure 2-4) from a 12 VDC ignition source originating from the vehicle. The controller will not operate until the ignition switch is activated.

Move the ON/OFF switch to the ON position. A green light will illuminate indicating that the controller has power. At the same time the evaporator fans will operate in either Low, Medium or High speed, depending on the Fan Speed switch position.

#### 2.3.2 Fan Speed Switch - 3 Speed

The evaporator fan speeds can be adjusted by pushing the rocker switch to the desired position:

- a. H = High Speed
- b. M = Medium Speed
- c. L = Low Speed

When the evaporator fan speed switch is positioned at the desired speed, a signal is sent to the corresponding fan speed relay located on the electrical circuit board.

#### 2.3.3 Adjusting Set Point (Interior Temperature Adjustment)

The potentiometer switch has an operating range between 60 and 85 degrees F. (+/- 1 degree F.).

Rotate the potentiometer switch knob to the right (clockwise) for maximum cooling.

Rotate the potentiometer switch knob to the left (counterclockwise) for less cooling.

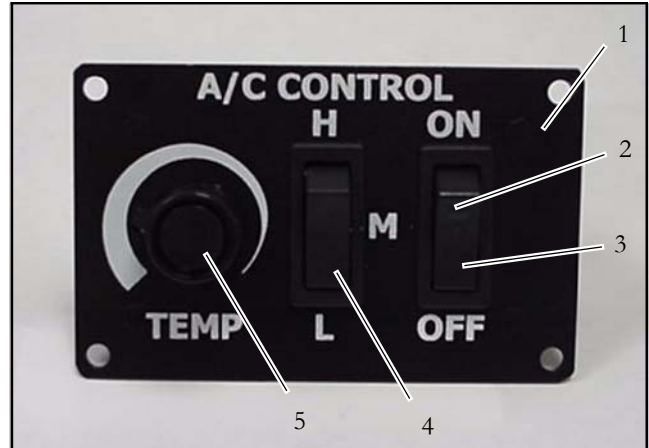

- 1 Face Plate
- 2 Green Light
- 3 Rocker Switch, 2 Position, ON/OFF
- 4 Rocker Switch, 3 Position, LOW-MED-HIGH
- 5 Temperature Switch (Potentiometer)

**Figure 2-3 Switch Assembly (TEMPCON)**

### 2.4 IN-LINE FUSE (FLORIDA CONTROL)

The controller is protected by a 3 Amp ATO in-line fuse (Figure 2-4). To replace the fuse do the following:

- a. Make sure ignition power is off.
- b. Grasp fuse cover at finger grips and lift off cover.
- c. Remove fuse and check if fuse is defective.
- d. Replace if needed.
- e. Push fuse cover back on to in-line holder.
- f. Restore ignition power and place ON/OFF switch to ON.

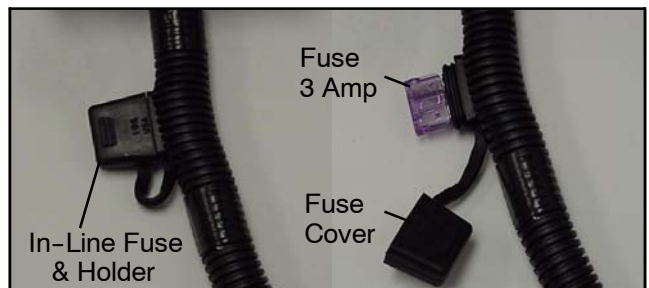
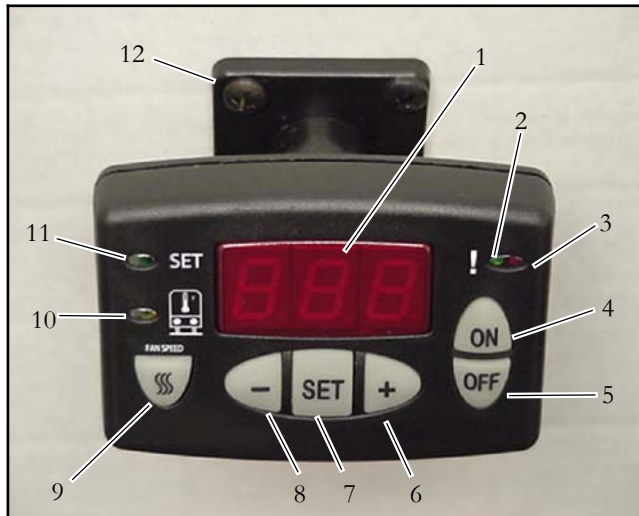

**Figure 2-4 In-Line Fuse & Holder (3 Amp)**



## 2.5 TOTAL CONTROL

The Total Control system consists of a Key Pad Display (See Figure 2-5) wired to an Electrical Control Panel (See Figure 2-7). Refer to Figure 2-5 for the following operating functions.



- 1 Display
- 2 Green LED, Cool Mode
- 3 Red LED, Heat Mode
- 4 ON Button
- 5 OFF Button
- 6 Increase Selection
- 7 SET Button
- 8 Decrease Selection
- 9 Fan Speed Button
- 10 Green LED, Inside Temperature
- 11 Green LED, Set Point
- 12 Total Control Mounting Assembly

Figure 2-5 Total Control Key Pad/Display

### 1 ON/OFF Button

Press the ON or OFF button to turn the system on or off. The display will show the temperature set point.

### 2 Return Air Temperature

If SET key is pressed the display will show return air (inside) temperature. With the inside temperature displayed, the green led on the left side of the display (which has the symbol of a bus with a thermal sensor) will be illuminated. If no key is pressed the display will go back to show set point after 30 seconds.

### 3 Adjusting Set Point

To adjust the set point, press the SET button.

The green SET led will illuminate on the left side of the display.

Press the + or - keys to bring the desired set point into the display.

If the set point is below the inside temperature, the cooling will come on. This will be characterized by a green led on the right side at the top of the display.

If the set point is above the inside temperature, heat will come on. This will be characterized by a red led on the right side at the top of the display.

### 4 Adjusting Fan Speed

Press the FAN SPEED button. The present setting (1 to 10) will show in the display.

Press the + or - button to adjust the fan speed. The number 10 represents the highest speed and the number 1 represents the lowest speed.

### 5 Alarms

With the alarm led flashing, the alarm code may be displayed by pressing the SET button. Refer Table 3-5 for system alarm code descriptions.

## 2.5.1 Total Control Operation

### 1 Control Stages

Temperature control will be regulated using 3 stages based on the return air temperature.

Cool

Null

Heat

When started, if the return air temperature sensor senses the temperature higher than the set point, the system will run cooling. When the return air temperature decreases to lower than the set point, cooling stage will stop and system will be in the null mode.

When started, if the return air temperature is lower than the set point, the system will run heating (refer to paragraph 2.8.5). When the return air temperature increases to higher than the set point, heating stage will stop and system will be in null mode.

In the null mode, if return air temperature increases to be out of the null band, system will run heating. If return air temperature decreases to be out of the null mode, system will run heating. The center of the null band is the set point and the width of the null band is controlled by microprocessor parameter P01.

For example, if the null band is 4 F and set point is 72° F, system will run cooling if temperature is higher than  $72 + 2 = 74$ . System will run heating if temperature is lower than  $72 - 2 = 70$ .



When in parameter, if no key is pressed for 5 seconds, the display will go back to default mode showing temperature set point.

**2 Modification Of Null Band Parameter P01**

Press and hold + and - key simultaneously for 5 seconds to access parameters programming mode.

P01 shows up on the display screen for 1 second and the current value of P01 will be shown. While viewing the current value, press + or - key to change the value of the parameter.

**3 Null Band**

The null differential can take the values of 2, 4, or 6° F, default to 2° F. See Figure 2-6

**4 Set Point Range**

The valid set point is from 60° F to 80° F.

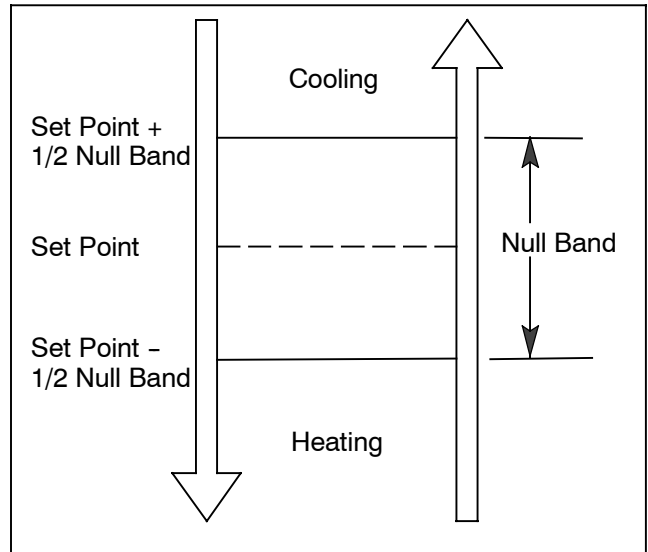

**Figure 2-6 Null Band**

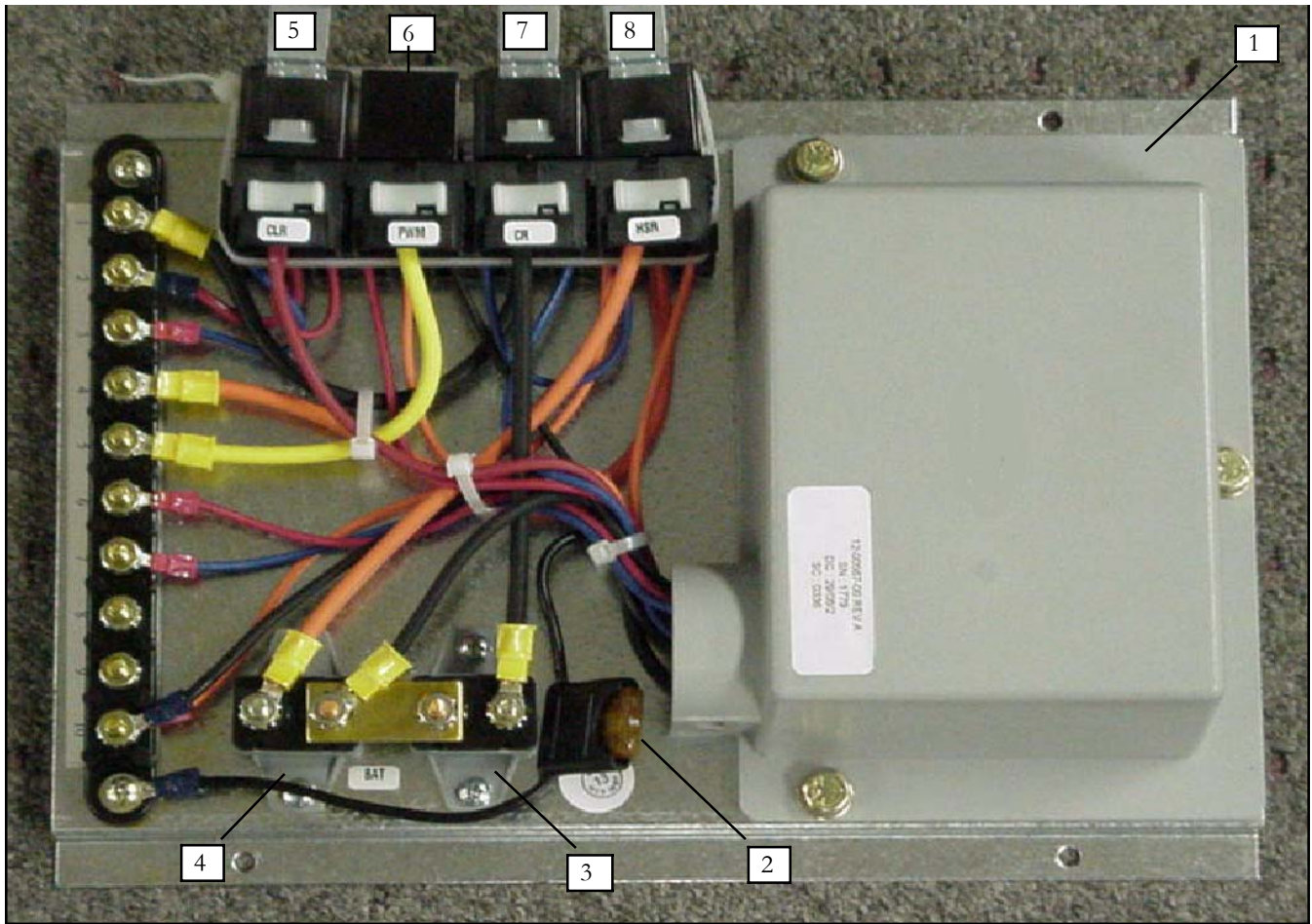

- |   |                              |   |   |
|---|------------------------------|---|---|
| 1 | Logic Module (Speed Control) | 5 | Clutch relay                                |
| 2 | Fuse (5 Amp)                 | 6 | Relay Filter - PWM (Pulse Width Modulation) |
| 3 | Circuit Breaker (Condenser)  | 7 | Condenser Relay                             |
| 4 | Circuit Breaker (High Speed) | 8 | High Speed Relay                            |

**Figure 2-7 Total Control Electrical Control Panel (Typical)**



## 2.6 GEN 4 - WITH TOTAL CONTROL, UNIT OPERATING INSTRUCTIONS

The controller is configured to operate with the GEN 5 unit by default. To operate as a GEN 4 unit controller, the following changes need to be made thru the controller. The operation of the controller is similar between the GEN 4 unit and the GEN 5 unit except the GEN 4 unit has only three speeds.

### a. Modification Of Parameter P01

Press and hold + or - keys simultaneously for 5 seconds to access parameters programing mode.

P01 shows up on the display screen for 1 second and the current value of P01 will be shown. While viewing the current value, press + to change the value of the parameter P01 =1. When in parameter, if no key is pressed for 5 seconds, the display will go back to default mode showing temperature set point.

### b. Fan Speed Selection

Press the Fan Speed button.

Press the + or - button to toggle between HIGH, MEDIUM, and LOW speeds.

NOTE: Other operating functions like setting the temperature, checking inside temperature, and alarm codes are similar between both Generation (GEN 4/ GEN 5) of units.

## 2.7 PRE-TRIP INSPECTION

After starting system operation, allow system to stabilize for ten to fifteen minutes and check for the following:

- 1 Listen for abnormal noises from the vehicle engine, evaporator and condenser areas.
- 2 Ensure evaporator and condenser fans are operating.
- 3 Water dripping from the evaporator or air ducts.
- 4 Reduced airflow. This is normally caused by dirty or clogged evaporator filters.

## 2.8 SEQUENCE OF OPERATION

Three types of control circuit are provided for split system equipment. They consist of the three position switch type, adjustable fan speed type and the Total Control type. Typical operating sequence descriptions for the various types are provided in the following subparagraphs.

### 2.8.1 Three Position Switch Operation

With Power to the ignition circuit breaker (see Figure 5-3) and battery circuit breaker the fan speed switch is placed in the LOW, MEDIUM or HIGH position to start the system. In the LOW and MEDIUM positions, power flows from the ignition circuit breaker through the fan speed switch and terminal board (TB) terminal 8 or 7 and the evaporator fan resistor to start the evaporator fans.

In the HIGH position, power flows through TB-1 to energize the high speed relay (HSR). HSR closes it's normally open contacts to provide power from the high speed fan circuit breaker through TB-2 and the evaporator fan resistor to start the evaporator fans.

Power also flows from the fan speed switch common terminal through the thermostat to TB-3. From TB-3 power flows to energize the condenser relay (CR) which closes it's normally open contacts to provide power from the battery circuit breaker through TB-4 to start the condenser fans (CM).

Power also flows from TB-3 through the low pressure switch (LP), high pressure switch (HP) and TB-5 to energize the clutch relay (CLR). Energizing CLR closes it's normally open contacts to provide power from the battery circuit breaker through TB-6 and energize the clutch. Energizing the clutch starts the compressor.

The operating sequence of a Tie-In system or a system with multiple evaporators, condensers or compressors is similar to the preceding description. Refer to Figure 5-4 for a typical Tie-In system schematic or Figure 5-5 for a multiple component schematic.





## 2.8.2 Variable Speed Control Operation

With Power to the ignition circuit breaker and battery circuit breakers (see Figure 5-6) the fan speed switch is brought to the desired speed position to start the system. Bringing the fan speed switch to the desired speed position closes the fan speed switch contacts to supply power to the input terminal of the thermostat and through the terminal board terminal TB-1 to energize the high speed relay (HSR) and optional hour meter. Energizing HSR closes a set of normally open contacts to supply power to the electronic speed control.

Power also flows through the fan speed switch potentiometer to provide a signal through TB-9 to the electronic speed control ADJ terminal. With this signal present, the electronic speed control will provide power to energize the evaporator blower at the desired speed.

With the thermostat calling for cooling, power flows from the thermostat output terminal, through TB-10, the Freeze-up thermostat and low pressure switch (optional location) to TB-3.

From TB-3, power flows to energize the condenser relay (CR). Energizing CR closes it's normally open contacts to provide power from the battery circuit breaker through TB-4 to start the condenser fans (CM).

Power also flows from TB-4 through the low pressure switch (LP - optional location), high pressure switch (HP) and TB-5 to energize the clutch relay (CLR). Energizing CLR closes it's normally open contacts to provide power from the battery circuit breaker through TB-6 and energize the clutch. Energizing the clutch starts the compressor.

## 2.8.3 Total Control - Gen 5 Operation

With Power to the battery circuit breakers (see Figure 5-7) the Total Control Key Pad ON button is pressed to start the system. The microprocessor will perform a voltage check (10 seconds) and then proceed to the start-up sequence. With voltage within the specified range, the microprocessor will provide power from the CFM+ terminal to energize the condenser relay (CR). Energizing CR closes it's normally open contacts to supply power from the battery circuit breaker through terminal board terminal TB-1 to start the condenser fan motors.

Two seconds after starting the condenser fans, the microprocessor will provide power from the CL terminal through TB-3, the low pressure switch (LP - optional location) and high pressure switch (HP) to

energize the clutch. Energizing the clutch starts the compressor.

Two seconds after starting the compressor, the microprocessor will provide power from terminal EFM+ to energize the high speed relay (HSR). Energizing HSR closes a set of normally open contacts to supply power through TB-4 to the electronic speed control. At the same time, the microprocessor will provide power from terminal BPV+ to energize the pulse width modulation relay (PWM). Energizing PWM closes a set of normally open contacts to allow regulated voltage from microprocessor terminal BPV- , through TB-5 to the electronic speed control adjustment (ADJ) terminal. The voltage output will begin at the lowest setting and then ramp up to the voltage required in accordance with the speed selection made at the Total Control Key Pad.

If at any time during operation the circuit from microprocessor terminal BPT+ back to terminal BPT- is opened by the freeze-up thermostat or low pressure switch (LP - optional location) the compressor clutch will be de-energized. Once the circuit is re-established, the clutch will be re-energized after a one minute delay.

When the system is installed as a tie-in system, power is supplied by the vehicle controls to the microprocessor ignition terminal (NEIM) when operation of the compressor is required by the in-dash defroster. With power to the NEIM terminal, the compressor clutch is energized.

## 2.8.4 Total Control - Gen 4 Operation

With Power to the battery circuit breakers (see Figure 5-9) the Total Control Key Pad ON button is pressed to start the system. The microprocessor will perform a voltage check (10 seconds) and then proceed to the start-up sequence. With voltage within the specified range, the microprocessor will provide power from the CFM+ terminal to energize the condenser relay (CR). Energizing CR closes it's normally open contacts to supply power from the battery circuit breaker through terminal board terminal TB-1 to start the condenser fan motors.

Two seconds after starting the condenser fans, the microprocessor will provide power from the CL terminal through TB-3, the low pressure switch (LP - optional location) high pressure switch (HP) and TB-2 to energize the clutch. Energizing the clutch starts the compressor.

Two seconds after starting the compressor, the microprocessor will start the evaporator fans in accordance with the speed selection made at the Total Control Key Pad.



If low speed is selected, the microprocessor will provide power from terminal EFM+ to energize the low speed relay (LSR). Energizing LSR closes its normally open contacts to provide power from the battery circuit breaker through TB-8 to the low speed resistor connection. It may be noted that the high speed relay (HSR) is also energized at this time. However, power is not available to the contacts of this relay so no action will result.

If medium speed is selected, the microprocessor will provide power from terminal BPV to energize the medium speed relay (MSR). Energizing MSR closes its normally open contacts to provide power from the battery circuit breaker through TB-5 to the medium speed resistor connection. It may be noted that power is also supplied to the high speed relay (HSR) at this time. However, the relay coil is not energized so no action will result.

If high speed is selected, the microprocessor will provide power from terminal EFM+ and BPV to energize the low speed relay (LSR), medium speed relay (MSR) and high speed relay (HSR). Energizing all three relays closes contacts to provide the required path from the battery circuit breaker through MSR, TB-5, HSR and TB-4 to the high speed resistor connection. Although all of the resistor connections are actually powered, powering of the high speed connection will bring the motors to high speed operation.

If at any time during operation the circuit from microprocessor terminal BPT+ back to terminal BPT- is opened by the freeze-up thermostat or low pressure switch (LP - optional location) the compressor clutch will be de-energized. Once the circuit is re-established, the clutch will be re-energized after a one minute delay.

When the system is installed as a tie-in system, power is supplied by the vehicle controls to the microprocessor ignition terminal (NEIM) when operation of the compressor is required by the in-dash defroster. With power to the NEIM terminal, the compressor clutch is energized.

On multiple compressor or multiple condenser systems, operation is similar to the preceding description except the second compressor is controlled from microprocessor terminal HP2+. Refer to Figure 5-8 for typical schematic diagram.

### **2.8.5 Heat Option**

When heat option is incorporated with the Total Control system, the heater valve will be controlled by the HGS2 terminal on the microprocessor.



### 2.9 EnviroMATE Controller (Single Zone)

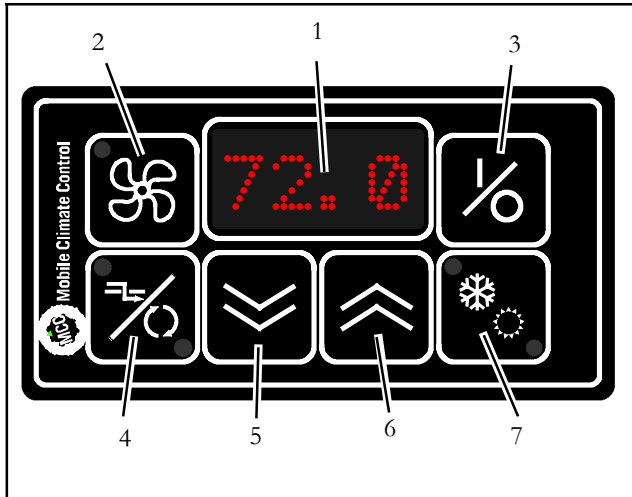

Figure 2-8 EnviroMATE Control Panel

- 1 Display
- 2 Vent Key
- 3 On/Off Key
- 4 Fresh Air Damper Key
- 5 Decrease Selection Key
- 6 Increase Selection Key
- 7 Cool/Heat Key

The Control Panel consist of the main CPU and keypad to control the air conditioning system operation. It is equipped with a numerical display to view operation status, fan speed and temperatures.

The Controller is designed to automatically operate system components to maintain desired temperature set point.

**NOTE**

**Controller parameters are factory set, and cannot be modified without factory authorization. If necessary, contact MCC's Technical Service Hot Line for assistance (800-450-2211) .**

#### 2.9.1 Controller Operation

Once the EnviroMATE controller is powered with 12VDC, supplied by the Bus OEM, the system can be turn On or Off using the On/Off key (Item 3 in Figure 2-8). When the display is powered On, the controller will go through self test mode, and then the current set point will be displayed. To adjust the

temperature set point up or down, use the Increase/Decrease selection keys (Items 5 and 6 in Figure 2-8). Temperature set point can be set from 64°F to 82°F (17.8°C to 27.8°C )

The controller is equipped with two temperature sensors to monitor the evaporator return air temperature, and the outside air temperature. To view the return air temperature, press and hold the Increase Selection Key for 3 seconds (Item 6 in Figure 2-8) . To view the outside air temperature, press and hold the Decrease Selection Key (Item 5 in Figure 2-8).

#### 2.9.2 Evaporator Fan Operation

Evaporator fan speeds are controlled automatically according to the chart shown below. There are 3 fan speeds controlled by relays mounted to an auxiliary electrical panel.

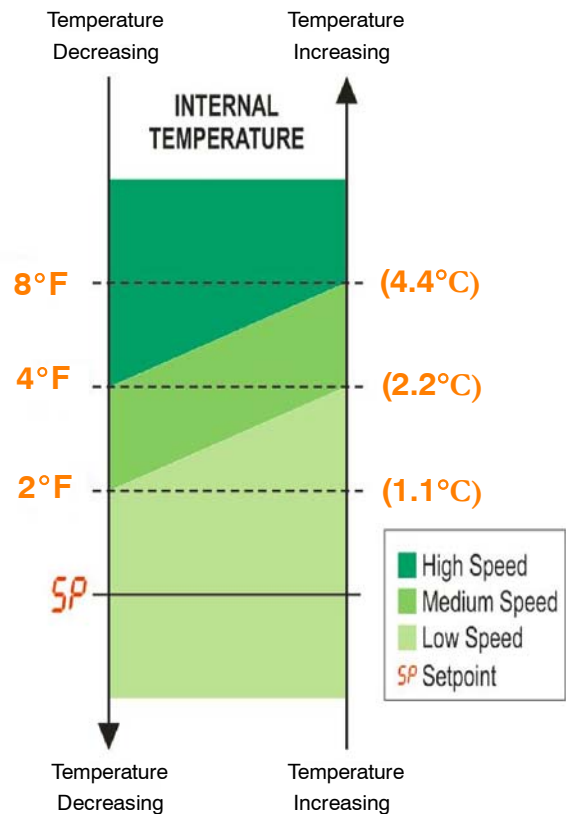



Fan speeds can be controlled manually by pressing the Vent Key (Item 2 in Figure 2-8), an LED light will activate in the corner of the Vent Key . After pressing the Vent Key, use the Increase/Decrease Keys (Item 5 and 6 in Figure 2-8) to set the desired fan speed. The display will show the following symbols, indicating selected speed:

- u1** = Low speed (Controller Output **Pin 4**)
- u2** = Medium speed (Controller Output **Pin 18**)
- u3** = High speed (Controller Output **Pin 19**)

### 2.9.3 Cooling Mode

When Cooling Mode is selected, the controller will check the Outside Air temperature. If the Outside Air temperature is below 24°F (-4.4°C), the compressor function will be disabled. If Outside Air temperature is above 24°F (-4.4°C), and the Return Air temperature is above the set point, the compressor will be energized by providing an output voltage from **Pin 6** of controller to enable cooling . The chart below shows the temperature control of the compressor operation.

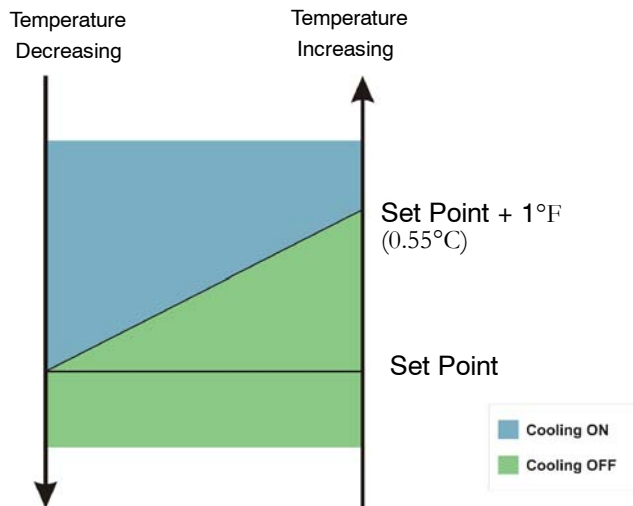

The controller will constantly monitor the low and high pressure switches to protect system components by monitoring voltage on **Pin 13** of controller from the compressor clutch relay output.. If the freeze up thermostat, or low pressure switch

circuit opens, the controller will de-energize the compressor clutch relay, and the condenser fan relay for a minimum time of 1 minute, or until the open circuit closes. If the high pressure switch circuit opens, the controller will de-energize the compressor clutch relay, and the condenser fan relay will remain energized to lower system pressure. The compressor relay will remain open for a minimum time of 1 minute, or until high pressure switch circuit closes.

If a low or high pressure condition occurs, an alarm will be generated and **HA** shown on the display. If either condition occurs 3 times within 30 minutes, the cooling circuit will be disabled until controller power is cycled and an alarm **LC** is shown on the display. Evaporator fans will remain energized to provide ventilation.

### 2.9.4 Heating Mode (If equipped)

The EnviroMATE Controller has the ability to control output to a heat control valve and boost pump (OEM supplied), to supply heat provided by the engine coolant system. If heat is selected by pressing the Cool/Heat Key (Item 7 in Figure 2-8), and the interior temperature is more than 1°F below set point, the controller will open a coolant heat valve to allow engine coolant flow to the heater coil until temperature rises to set point.

### 2.9.5 Sensors

The EnviroMATE Controller constantly monitors the Return Air (Controller **Pins 15 & 11**) and Outside Air sensors (Controller **Pins 3 & 7**). In the event the sensor or related wiring causes an Open or Shorted condition, the controller will default that particular sensor value to 72°F (22.2°C). An alarm will be generated and either **F1** or **F2** will be shown on the display screen.

### 2.9.6 Voltage

The EnviroMATE Controller monitors the voltages being supplied by the OEM by fused circuits on **Pins 1 & 9** at the controller. In the event of a low voltage (below 10 VDC), or an alternator failure, the system will be disabled, and an alarm **bL** or **AL** will be shown on the display.

### 2.9.7 Schematics

Typical system schematic for an EnviroMATE single loop system can be found in Section 5, Figure 5-10.



**2.9.8 Alarm Descriptions**

| <b>FAILURE</b> | <b>DESCRIPTION</b>                         |
|----------------|--|
| HA             | Pressure switch failure                    |
| F1             | Internal temperature sensor failure        |
| F2             | External temperature sensor failure        |
| bL             | Battery lower 10 VDC failure               |
| AL             | Alternator failure                         |
| LC             | 3 Pressure switch failures (HA) in 30 min. |
| Pd             | Discharge pressure failure                 |
| Ps             | Suction pressure failure                   |

**Figure 2-9 EnviroMATE Alarms (Single Zone)**



### 2.10 EnviroMATE Controller (Dual Zone)

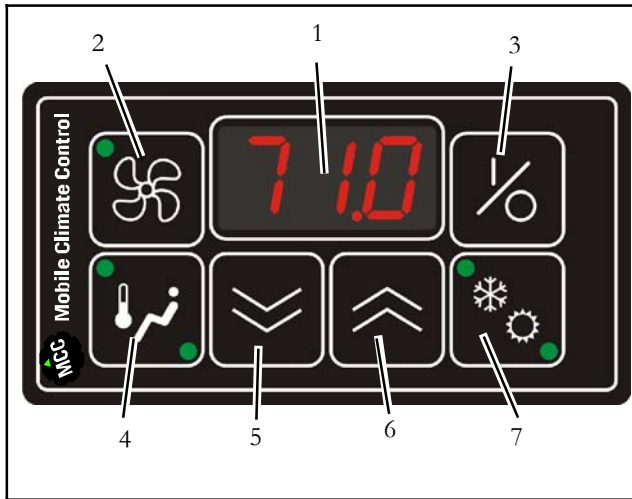

Figure 2-10 EnviroMATE Control Panel

- 1 Display
- 2 Vent Key
- 3 On/Off Key
- 4 Temperature Zone Key
- 5 Decrease Selection Key
- 6 Increase Selection Key
- 7 Cool/Heat Key

The Control Panel consist of the main CPU and keypad to control the air conditioning system operation. It is equipped with a numerical display to view operation status, fan speed and temperatures.

The Controller is designed to automatically operate system components to maintain desired temperature set point.

**NOTE**

**Controller parameters are factory set, and cannot be modified without factory authorization. If necessary, contact MCC's Technical Service Hot Line for assistance (800-450-2211) .**

#### 2.10.1 Controller Operation

Once the EnviroMATE controller is powered with 12 VDC, supplied by the Bus OEM, the system can be turn On or Off using the On/Off key (Item 3 in Figure 2-8). When the display is powered On, the controller will go through self test mode, and then the current set point will be displayed. To adjust the temperature set point up or down, use the Increase/Decrease selection keys (Items 5 and 6 in Figure 2-8). Temperature set point can be set from 64°F to 82°F (17.8°C to 27.8°C).

The controller is equipped with two return air temperature sensors, one in each zone to monitor the evaporator return air temperature. To view the return air temperature for Zone 1, press the Temperature Zone Key once (Item 4 in Figure 2-10). The green LED light in upper left corner of Key will light, indicating Zone 1 return air temperature. Return air temperature will be shown on display.

To view the return air temperature for Zone 2, press the Temperature Zone Key again (Item 4 in Figure 2-10). The green LED light in bottom right corner of Key will light, indicating Zone 2 return air temperature. Return air temperature will be shown on display.

| Led | Temperature shown |
|-----|-------------------|
|     | Zone 1            |
|     | Zone 2            |

After a few seconds, the display will return to the set point temperature.





## 2.10.2 Evaporator Fan Operation (Automatic)

Evaporator fan speeds are controlled automatically according to the chart shown below. There are 3 fan speeds controlled by relays mounted to an auxiliary electrical panel. Each zone will control the evaporator fan speeds in that zone, according to the return air temperature sensor controlling that particular zone.

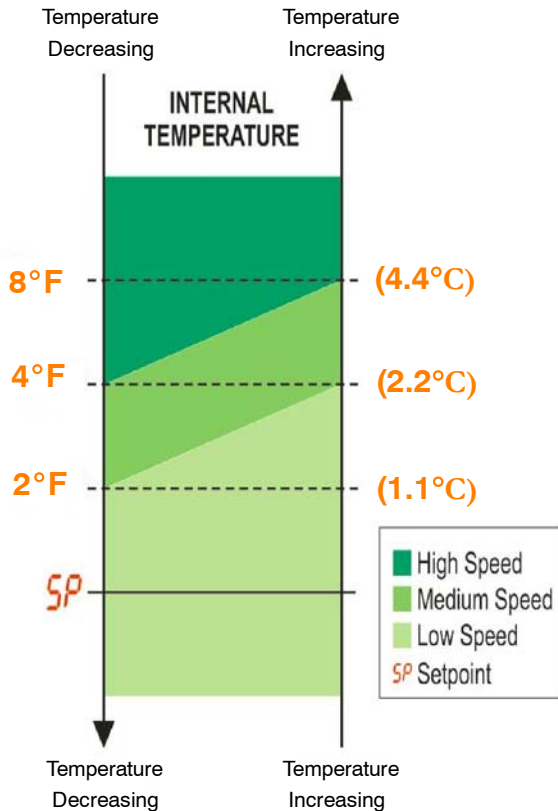

## 2.10.3 Evaporator Fan Operation (Manual)

Fan speeds can be controlled manually by pressing the Vent Key (Item 2 in Figure 2-10), an LED light will activate in the corner of the Vent Key. After pressing the Vent Key, use the Increase/Decrease Keys (Item 5 and 6 in Figure 2-10) to set the desired fan speed. The display will show the following symbols, indicating selected speed:

**u1** = Low speed

(Controller Output **Pin 4** for Zone 1, **Pin 12** for Zone 2)

**u2** = Medium speed

(Controller Output **Pin 18** for Zone 1, **Pin 24** for Zone 2)

**u3** = High speed

(Controller Output **Pin 19** for Zone 1, **Pin 23** for Zone 2)

## 2.10.4 Cooling Mode

When Cooling Mode is selected (Item 7 in Figure 2-10), The green LED light will display in upper left corner of Key by the “Snowflake” symbol. The controller will then compare the return air temperature value for each Zone, with the selected set point temperature. If the value of the return air temperature for Zone 1 is more than 1°F (0.55°C) above system set point, the controller will output a signal on **Pin 6** of controller to energize the condenser and compressor for cooling.

If the value of the return air temperature for Zone 2 is more than 1°F (0.55°C) above system set point, the controller will output a signal on **Pin 10** of controller to energize the condenser and compressor for cooling.

Each zone will control the system components for cooling independently according to need.

The chart below shows the temperature control of the compressor operation.

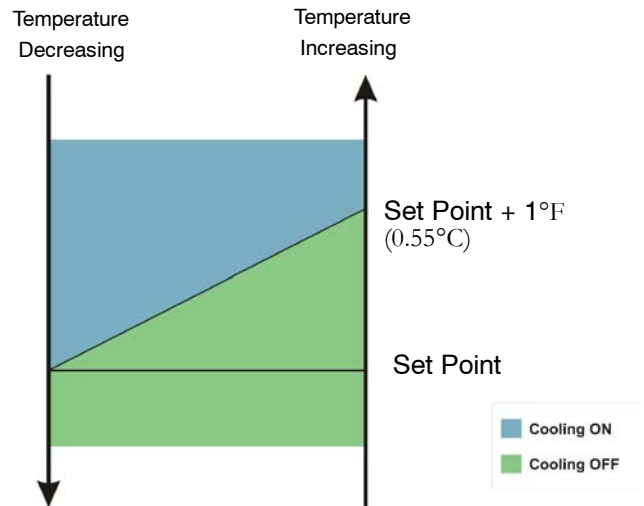

The controller will constantly monitor the low pressure switch and freeze up thermostat to protect system components by monitoring voltage on **Pin 14** (Zone 1), and **Pin 16** (Zone 2) of controller. If the freeze up thermostat, or low pressure switch circuit opens, the controller will de-energize the compressor clutch relay, and the condenser fan relay for a minimum time of 1 minute, or until the open circuit closes.

The controller will constantly monitor the high pressure switch to protect system components by monitoring voltage on **Pin 13** (Zone 1), and **Pin 5** (Zone 2) of controller. If the high pressure switch circuit opens, the controller will de-energize the



compressor clutch relay, and the condenser fan relay will remain energized to lower system pressure. The compressor relay will remain open for a minimum time of 1 minute, or until high pressure switch circuit closes.

If a low or high pressure condition occurs, an alarm will be generated and shown on the display. The alarms related to low and high pressure are listed below:

**L1- Low pressure failure (Zone 1)**

**L2- Low pressure failure (Zone 2)**

**H1- High pressure failure (Zone 1)**

**H2- High pressure failure (Zone 2)**

If any condition occurs 3 times within 30 minutes, the cooling circuit will be disabled for the associated Zone until controller power is cycled. An alarm will be generated to indicate this occurrence and shown on the display. Evaporator fans will remain energized to provide ventilation. Lock out of cooling system alarms will show as:

**t1- Lock out of Zone 1 cooling system**

**t2- Lock out of Zone 2 cooling system**

## 2.10.5 Heating Mode (If equipped)

The EnviroMATE Controller has the ability to control output to a heat control valve and boost pump (OEM supplied) to supply heat provided by the engine coolant system. If heat is selected by pressing the Cool/Heat Key (Item 7 in Figure 2-8), and the interior temperature is more than 1°F below set point, the controller will open the coolant heat valve and allow engine coolant to be provided to the heater coil (if equipped), until temperature rises back to set point temperature.

## 2.10.6 Sensors

The EnviroMATE Controller constantly monitors the Return Air sensors (Controller **Pins 11 & 15 for Zone 1**) and (Controller **Pins 3 & 7 for Zone 2**). In the event the sensor or related wiring causes an Open or Shorted condition, the controller will generate an alarm and either **F1 (Zone 1)** or **F2 (Zone 2)** will be shown on the display screen. The controller response will assume a default value of 72°F (22.2°C) for the affected sensor.

## 2.10.7 Voltage

The EnviroMATE Controller monitors the voltages being supplied by the OEM by fused circuits on **Pins 1 & 9** at the controller. In the event of a low voltage (below 10 VDC), or an alternator failure, the system will be disabled, and an alarm **bL** or **AL** will be shown on the display.

## 2.10.8 Schematics

Typical system schematics for an EnviroMATE dual loop system can be found in Section 5, Figure 5-11 and Figure 5-12.





2.10.9 Alarm Description (Dual Zone)

| Failure   | Description                                   | Action  |
|-----------|---|---|
| <b>F1</b> | Temperature zone 1 sensor fail                | Assume the temperature of 72°C  |
| <b>F2</b> | Temperature zone 2 sensor fail                | Assume the temperature of 72°C  |
| <b>AL</b> | Alternator failure                            | Only ventilation enabled  |
| <b>bL</b> | Voltage lower than 10V <sub>DC</sub> -----    | -----   |
| <b>L1</b> | Low pressure failure (Group 1)                | Turn OFF compressor 1   |
| <b>H1</b> | High pressure failure (Group 1)               | Turn OFF compressor 1   |
| <b>L2</b> | Low pressure failure (Group 2)                | Turn OFF compressor 2   |
| <b>H2</b> | High pressure failure 1 (Group 2)             | Turn OFF compressor 2   |
| <b>t1</b> | 3 Failures of <b>L1</b> or <b>H1</b> in 30min | Lock the compressor activation 1 and return activating only after reset |
| <b>t2</b> | 3 Failures of <b>L2</b> or <b>H2</b> in 30min | Lock the compressor activation 2 and return activating only after reset |

Figure 2-11 EnviroMATE Alarms (Dual Zone)



## SECTION 3 TROUBLESHOOTING

### 3.1 INSUFFICIENT OR NO COOLING

#### 3.1.1 Preliminary Checks

Make certain that the evaporator filters are not clogged with dirt. Check to make certain that all vehicle body openings are air tight. Check the adjustment and condition of the compressor drive belt (s); adjust or replace as necessary. Refer to Section 4, paragraph 4.12 for complete drive belt installation and maintenance procedures.

#### 3.1.2 Checking System Air Output

If the evaporator air flow appears less than normal, check the evaporator filter and coil for dirt and obstructions. Clean where necessary. Check the blower assembly for proper operation. Current draw will vary as to evaporator, speed setting and voltage. See Table 3-1, Table 3-2 or Table 3-3 for approximate evaporator current draw. If the current drawn by the motor is not to specifications, replace the motor.

#### 3.1.3 Check The Sight Glass For Bubbles

If the preceding steps do not remedy the problem, check the sight glass for bubbles. Run the vehicle engine at high idle (approximately 1200 RPM) while maintaining a minimum discharge pressure of 150 psig. The thermostatic switch should be positioned for maximum cooling.

Bubbles in the sight glass may indicate an undercharge of refrigerant and/or a restriction in the liquid line. If the charge is low, check the system for leaks; repair if necessary and charge the system with the proper amount of refrigerant.

#### NOTE

Under certain ambient conditions a few bubbles may appear in the sight glass. Refer to Section 4, Table 4-5 to determine if system has correct charge.

No bubbles in the sight glass will indicate either a full charge or a complete loss of refrigerant. To determine if there is refrigerant in the system, run the vehicle engine at high idle (approximately 1200 RPM) with the thermostatic switch positioned for maximum cooling. Allow system to stabilize, then shut system down while observing the sight glass. If bubbles begin to appear, the system has a refrigerant charge. If no bubbles appear, system is without refrigerant.

A restriction in the liquid line can be found by feeling the liquid line. Any portion that is cold to the touch or that frosts up is restricting the refrigerant flow.

#### 3.1.4 Compressor Amp Draw

Split System Compressor clutch coils typically draw 2 to 3 Amps.



**Table 3-1 Evaporator Current Draw (GEN 4)**

| MODEL | VOLTAGE  | SPEED SETTING AND AMP DRAW (COLOR) |                 |                 |                      |
|-------|----------|------------------------------------|-----------------|-----------------|----------------------|
|       |          | LOW - (Red)                        | MED. - (Yellow) | HIGH - (Orange) | HIGH PERF. - (Black) |
| EM-1  | 12.5 VDC | 8.6 Amp                            | 14.4 Amp        | 18.5 Amp        | 30 Amp               |
|       | 13.5 VDC | 10 Amp                             | 15 Amp          | 19.4 Amp        | 32 Amp               |
|       | 24.5 VDC | 7.8 Amp                            | 10.7Amp         | 12.7 Amp        | 16 Amp               |
| EM-2  | 12.5 VDC | 5.0 Amp                            | 8.0 Amp         | 10 Amp          | 17 Amp               |
|       | 13.5 VDC | 6.0 Amp                            | 9.0 Amp         | 12 Amp          | 20 Amp               |
|       | 25 VDC   | 4.5 Amp                            | 6.0 Amp         | 6.5 Amp         | 9 Amp                |
| EM-3  | 12.5 VDC | 11 Amp                             | 22 Amp          | 28 Amp          | 47 Amp               |
|       | 13.5 VDC | 12 Amp                             | 25 Amp          | 30 Amp          | 52 Amp               |
|       | 24.5 VDC | 6.0 Amp                            | 14 Amp          | 17 Amp          | 21 Amp               |
| EM-6  | 12.5 VDC | 4.6 Amp                            | 7.5Amp          | 9.4 Amp         | 16 Amp               |
|       | 13.5 VDC | 5.1 Amp                            | 8.4 Amp         | 10.6 Amp        | 19.3 Amp             |
|       | 24.5 VDC | 4.0 Amp                            | 6.0 Amp         | 7.0 Amp         | 9.0 Amp              |
| EM-9  | 12.5 VDC | 8.1 Amp                            | 15 Amp          | 32 Amp          | 37.1 Amp             |
|       | 13.5 VDC | 10.3 Amp                           | 18 Amp          | 33.2 Amp        | 37.4 Amp             |
| EM-14 | 12.5 VDC | 7.0 Amp                            | 10 Amp          | 21 Amp          | Not Applicable       |
|       | 13.5 VDC | 8.0 Amp                            | 11 Amp          | 23 Amp          | Not Applicable       |
|       | 24.5 VDC | 4.0 Amp                            | 6.0 Amp         | 10 Amp          | Not Applicable       |
| IW-1  | 12.5 VDC | 7.7 Amp                            | 11.5 Amp        | 24 Amp          | -                    |
| IW-2  | 12.5 VDC | -                                  | -               | 21 Amp          | -                    |
| IW-7  | 12.5 VDC | -                                  | -               | 15 Amp          | -                    |
| IW-14 | 12.5 VDC | 7.0 Amp                            | -               | 18 Amp          | -                    |



**Table 3-2 Evaporator Current Draw (GEN 5)**

| MODEL | VOLTAGE  | SPEED SETTING (3) AND AMP DRAW |              |            |
|-------|----------|--------------------------------|--------------|------------|
|       |          | LOW - AMP                      | MEDIUM - AMP | HIGH - AMP |
| EM-1  | 13.5 VDC | 9.7 Amp                        | 17.9 Amp     | 29.5 Amp   |
|       | 24.5 VDC |                                |              |            |
| EM-2  | 13.5 VDC | 8.8 Amp                        | 13.3 Amp     | 24.3 Amp   |
|       | 24.5 VDC |                                |              |            |
| EM-3  | 13.5 VDC | 16 Amp                         | 32.2 Amp     | 46 Amp     |
|       | 24.5 VDC |                                |              |            |
| EM-7  | 13.5 VDC | 7 Amp                          | 11.5 Amp     | 15.9 Amp   |
|       | 24.5 VDC |                                |              |            |

| MODEL | VOLTAGE  | VARIABLE SPEED CONTROL - AMP DRAW |  |
|-------|----------|-----------------------------------|--|
|       |          | HIGH SPEED - MAX                  |  |
| EM-1  | 12.5 VDC | Fully Loaded 29.5 Amp             |  |
|       | 13.5 VDC | Fully Loaded 30.1 Amp             |  |
|       | 24.5 VDC | Fully Loaded 16 Amp               |  |
| EM-2  | 12.5 VDC | Fully Loaded 23 Amp               |  |
|       | 13.5 VDC | Fully Loaded 24.3 Amp             |  |
|       | 24.5 VDC | Fully Loaded 12 Amp               |  |
| EM-3  | 12.5 VDC | Fully Loaded 46 Amp               |  |
|       | 13.5 VDC | Fully Loaded 46 Amp               |  |
|       | 24.5 VDC | Fully Loaded 24 Amp               |  |
| EM-7  | 12.5 VDC | Fully Loaded 15 Amp               |  |
|       | 13.5 VDC | Fully Loaded 15.9 Amp             |  |
|       | 24.5 VDC | Fully Loaded 10 Amp               |  |

**Table 3-3 Condenser Current Draw (GEN 5)**

| MODEL                 | VOLTAGE            | AMP DRAW               |
|-----------------------|--------------------|------------------------|
| CM-2                  | 13.5 VDC           | 14.5 Amp               |
| CM-2 With Vector Fans | 13.5 VDC           | 13.5 Amp               |
| CM-3                  | 13.5 VDC           | 22.5 Amp               |
| CM-3 With Vector Fans | 13.5 VDC           | 20.5 Amp               |
| CM-14                 | 13.5 VDC           | 27.8 Amp               |
| KR-2                  | 13.5 VDC<br>25 VDC | 14.0 Amp<br>10.0 Amp   |
| KR-3                  | 13.5 VDC<br>25 VDC | 21.0 Amp<br>16.0 Amp   |
| KR-4                  | 13.5 VDC<br>25 VDC | 44.0 Amps<br>22.0 Amps |

**Note: Condenser Amp Draw Increases As Static Pressure Increases**



Table 3-4 GENERAL SYSTEM TROUBLESHOOTING PROCEDURES

| INDICATION/<br>TROUBLE                               | POSSIBLE CAUSES  |
|--|--|
| <b>3.2 SYSTEM WILL NOT COOL</b>                      |  |
| Compressor will not run                              | Drive-Belt loose or defective<br>Clutch coil defective<br>Clutch malfunction<br>Low refrigerant charge<br>Compressor malfunction   |
| Electrical Malfunction                               | Circuit Breaker Open<br>Relay Defective  |
| <b>3.3 SYSTEM RUNS BUT HAS INSUFFICIENT COOLING</b>  |  |
| Compressor   | Drive-Belt loose or defective<br>Compressor defective  |
| Refrigeration system                                 | Abnormal pressures<br>No or restricted evaporator air flow<br>Expansion valve malfunction<br>Restricted refrigerant flow<br>Low refrigerant charge   |
| <b>3.4 ABNORMAL PRESSURES</b>                        |  |
| High discharge pressure                              | Refrigerant overcharge<br>Noncondensables in system<br>Condenser motor(s) failure<br>Dirty Condenser coil<br>Skirt-Mounted Condenser recirculating hot air from under bus.   |
| Low discharge pressure                               | Compressor defective<br>Low refrigerant charge   |
| High suction pressure                                | Compressor defective   |
| Low suction pressure                                 | Filter-drier or Receiver-Drier partially plugged<br>Low refrigerant charge<br>Expansion valve malfunction<br>Restricted air flow   |
| Suction and discharge pressures equal or near equal  | Compressor valves defective  |
| <b>3.5 ABNORMAL NOISES, VIBRATIONS OR CONDITIONS</b> |  |
| Compressor - Engine area                             | Compressor or compressor mounting loose<br>Liquid slugging<br>Insufficient oil<br>Excessive oil<br>Clutch loose, rubbing or defective<br>Dirt or debris on vehicle fan blades<br>Drive belt cracked, worn or loose |
| Evaporator area                                      | Evaporator blower assembly broken or loose<br>Blower wheel loose or out of alignment<br>Blade interference   |
| Condenser area                                       | Broken or missing fan blade<br>Condenser assembly loose<br>Fan assembly loose  |



Table 3-4 GENERAL SYSTEM TROUBLESHOOTING PROCEDURES - Continued

|  |  |
|--|--|
| <b>3.6 NO EVAPORATOR AIR FLOW OR RESTRICTED AIR FLOW</b> |  |
| Air flow through coil blocked                            | Coil frosted over<br>Dirty coil<br>Dirty filter assembly   |
| No or partial evaporator air flow                        | Motor running in reverse<br>Motor(s) defective<br>Evaporator fan loose or defective<br>Fan damaged<br>Dirty filter<br>Icing of coil<br>Fan speed relay(s) defective<br>Fan rotation incorrect      |
| <b>3.7 EXPANSION VALVE MALFUNCTION</b>                   |  |
| Low suction pressure                                     | Low refrigerant charge<br>Ice formation or dirt at block valve orifice   |
| <b>3.8 CONTROL SYSTEM MALFUNCTION</b>                    |  |
| Will not operate/control                                 | Circuit breaker or relay defective<br>Fan speed switch defective<br>Thermostat defective<br>Microprocessor controller malfunction (Total Control)  |
| <b>3.9 NO OR INSUFFICIENT HEATING</b>                    |  |
| Insufficient heating                                     | Dirty or plugged heater core<br>Coolant heat valve(s) malfunctioning or plugged<br>Low coolant level<br>Hand valve(s) partially closed<br>Water pump defective<br>Auxiliary Heater malfunctioning. |
| No Heating   | Hand valve(s) closed<br>Coolant heat valve(s) malfunctioning or plugged<br>Pump(s) malfunctioning  |
| Continuous Heating                                       | Hand valve(s) defective<br>Coolant heat valve(s) malfunctioning<br>Debris under heat valve diaphragm   |



**Table 3-5 TROUBLESHOOTING ALARM CODES (TOTAL CONTROL)**

| <b>ALARM CODE</b> | <b>TITLE</b>                     | <b>CAUSE</b>  | <b>REMEDY</b>   |
|-------------------|----------------------------------|---|---|
| AL 13             | Return air sensor.               | Open circuit or short circuit on the return air sensor connection.  | Check connections on RAS + and RAS - on the control board. Make sure the Red terminal is connected to RAS + and Black terminal is connected to RAS - on the control board.  |
| AL 15             | Set point out of range           | Wrong set point is saved on the controller.   | Controller will correct this problem automatically.   |
| AL 17             | Not Used                         |   |   |
| AL 21             | Low Voltage                      | Controller senses battery voltage is less than 10 volts.  | Check battery voltage.  |
| AL 27             | Compressor 1 pressure alarm      | <p>Open or short circuit in the clutch related circuit (CLHR on the control board) such as:</p> <p>High pressure switch open circuit.</p> <p>Low pressure switch open circuit, if the low pressure switch is in series with the high pressure switch in the condenser.</p> <p>Wire from controller CLHR to terminal 3 on the electrical panel terminal board is open.</p> <p>Wire from terminal 3 to condenser is open, short to ground or short to battery.</p> <p>Wire from terminal 2 to clutch is open, short to ground or short to battery.</p> <p>Wire from clutch to ground is open.</p> <p>Clutch coil open or short circuit.</p> | <p>Turn off the controller by pressing OFF button.</p> <p>Measure the resistance between terminal 3 and terminal 2 on the electrical panel. The reading should be less than 1 OHM. This is to check the pressure switch circuit. If the resistance is too high, look for open circuit on the high pressure or low pressure switches.</p> <p>Measure the resistance between terminal 2 to ground. The readings should be about 6 OHM. This is to check the clutch coil. If readings are low, look for an open circuit in the clutch coil.</p> <p>Check with power on:</p> <p>Connect voltmeter to terminal 3 and ground. Press the ON button on the controller and wait for 10 seconds. If you see 12 VDC appear for about 1 second and disappears, the circuit from CLHR on control board to terminal 3 is good but circuit from terminal 3 to clutch is open.</p> <p>Connect voltmeter to terminal 2 and ground. Turn on controller by pressing the ON button. Wait for about 10 seconds. If you see 12 VDC appear for 1 second and disappear, the circuit from CLHR on control to terminal 2 is good but the circuit from terminal 2 to clutch is open.</p> <p>If the 12 VDC does not appear, then the pressure switch circuit is open. Follow the procedure mentioned above for tracing the pressure switch circuit.</p> |
| AL 41             | Compressor 2 pressure alarm      | Open circuit on compressor 2 high pressure circuit.   | <p>If the second compressor is used follow the procedure for Alarm 27.</p> <p>If the second compressor is not used, there should be a jumper wire between HP2 + and HP - on the control board inputs.</p>   |
| AL 43             | Condenser fan relay malfunction  | Short circuit between CFM + and CFM - on the control board.   | Check condenser fan relay CR and its related circuit.   |
| AL 44             | Evaporator fan relay malfunction | Short circuit between EFM + and EFM - on the control board.   | Check evaporator fan relay HSR and the related circuits.  |
| AL 45             | Clutch Relay malfunction         | Malfunction is detected on the CLR output.  |   |
| AL 46             | EFS Control malfunction          | Malfunction is detected on the EFS output.  |   |



| Table 3-5 TROUBLESHOOTING ALARM CODES (TOTAL CONTROL) Cont:: |                           |   |  |
|--|---------------------------|---|--|
| AL 47  | Not Used                  |   |  |
| AL 48  | Heating Valve malfunction | Malfunction is detected on the HV output. |  |

**NOTE**

If the controller calls for cooling (green led is on), the condenser and evaporator fans are running, but the compressor is OFF without any alarm code, this indicates one of the following has occurred:

1. The freeze stat is open. The compressor is disabled when the freeze stat is open and will be enabled when the freeze stat is closed.
2. The low pressure switch, also present in the evaporator (GEN 5 units) which is in series with the freeze stat is open.
3. The compressor is disabled by minimum off time. When the compressor is turned OFF by temperature control, freeze stat, low or high pressure switches, it will remain OFF for a minute (60 seconds) before it is re-energized. This protects the compressor clutch from short cycling.





SECTION 4
SERVICE



Be sure to observe warnings listed in the safety summary in the front of this manual before performing maintenance on the air conditioning system

4.1 PREVENTATIVE MAINTENANCE SCHEDULE

Table with columns: SYSTEM (ON, OFF) and OPERATION. Rows include: a. Daily Maintenance, b. Weekly Maintenance, c. Monthly Maintenance, d. Quarterly Inspection, e. Semi-Annual Inspection and Maintenance, f. Annual Inspection and Maintenance.



### 4.2 MAINTENANCE PROCEDURES

The following air conditioning service equipment is required in order to properly perform the maintenance procedures.

1.. **Manifold Gauge Set** MCC P/N 07-00294-00 Provides access to and monitors pressures within the system. Manifold gauge sets are available in different configurations and styles. 3-way or 4-way, liquid filled gauges, with or without a sight glass, 3 hoses or 4 hoses, 1/4 inch or 3/8 inch manifold connections, etc. Familiarize yourself with the proper operation of your manifold gauge set before attempting any service.

2.. **R134a Low Side (Suction) Coupler** MCC P/N 07-00307-04 - Connects the air conditioning system Suction Access Port to the Manifold Gauge Set.

3.. **R134a High Side (Discharge) Coupler** MCC P/N 07-00307-05 - Connects the air conditioning system Discharge Access Port to the Manifold Gauge Set.

4.. **Vacuum Pump - 2 Stage (5 CFM Minimum)** MCC P/N 07-00176-11 - Removes moisture and air from the air conditioning system in order to obtain required micron level.

5.. **Micron Gauge, Digital** MCC P/N 07-00414-00 Monitors the evacuation process in units of microns. Micron gauges can be either digital (electronic) or analog.

6.. **Recovery/Recycle Machine (R134a)** MCC P/N MVS-115-F-L-CT (115VDC), MVS-240-F-L-CT (240 VDC) - Recovers and recycles R134a refrigerant that is present within the air conditioning system.

7.. **Refrigerant Scale** MCC P/N 07-00315-00 - Accurately weighs the transfer of refrigerant into the air-conditioning system.

8.. **Refrigerant Cylinder** - Storage tank for R134a.

9.. **Heat Blanket** - Used to increase internal temperature of the refrigerant cylinder, greatly increasing the transfer of refrigerant to the air conditioning system.

10.. **Oil Injector** - Used to add additional amounts of oil to a closed system.

### 4.3 INSTALLING MANIFOLD GAUGES

The manifold gauge set (see Figure 4-1) is used to determine system operating pressures, add refrigerant charge, and to equalize or evacuate the system.

When the suction pressure hand valve is frontseated (turned all the way in), the suction (low) pressure can be checked. When the discharge pressure hand valve is frontseated, the discharge (high) pressure can be checked. When both valves are open (turned counter-clockwise all the way out), high pressure vapor will flow into the low side. When the suction pressure valve is open and the discharge pressure valve shut, the system can be charged.

A R-134a manifold gauge/hose set with self-sealing hoses is required for service of the models covered within this manual. The manifold gauge/hose set is available from Mobile Climate Control. (Mobile Climate Control P/N 07-00294-00, which includes items 1 through 6, Figure 4-1 .) To perform service using the manifold gage/hose set, do the following:

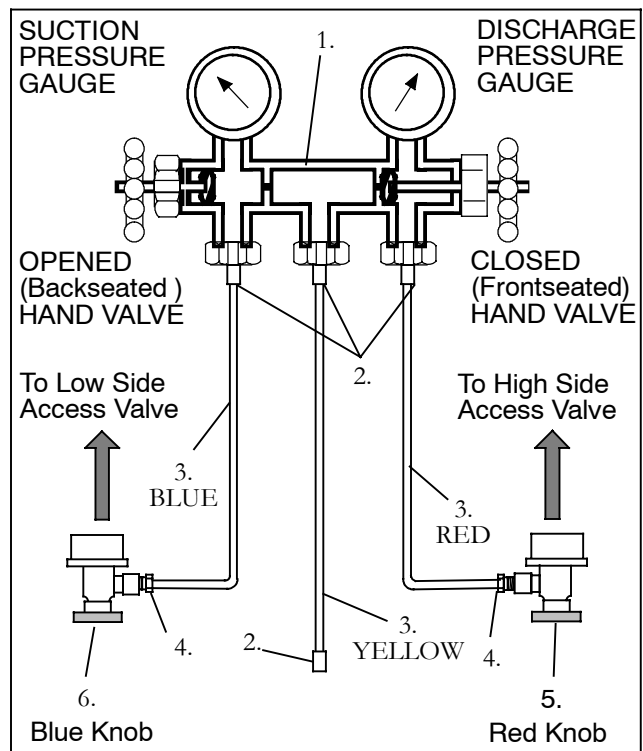

- 1.. Manifold Gauge Set
- 2.. Hose Fitting (0.5-16 Acme)
- 3.. Refrigeration and/or Evacuation Hose (SAE J2196/R-134a)
- 4.. Hose Fitting w/O-ring (M14 x 1.5)
- 5.. High Side Field Service Coupling
- 6.. Low Side Field Service Coupling

Figure 4-1 Manifold Gauge Set



## a. Preparing Manifold Gauge/Hose Set For Use

- 1.. If the manifold gauge/hose set is new or was exposed to the atmosphere it will need to be evacuated to remove contaminants and air as follows:
- 2.. Backseat (turn counterclockwise )both field service couplings (see Figure 4-1) and midseat both hand valves.
- 3.. Connect the yellow hose to a recovery machine, vacuum pump or refrigerant 134a cylinder. Depending on tools available and service to be performed.
- 4.. Evacuate to 10 inches of vacuum and then charge with R-134a to a slightly positive pressure of 0.1 kg/cm@ (1.0 psig).
- 5.. Front seat both manifold gauge set valves and disconnect from cylinder. The gauge set is now ready for use.

## b. Connecting Manifold Gauge/Hose Set

To connect the manifold gauge set, (See Figure 4-2) do the following.

- 1.. Connect the high side field service coupling (see Figure 4-1) to the discharge line service valve port.
- 2.. Turn the high side field service coupling knob (red) clockwise, which will open the high side of the system to the gauge set.
- 3.. Connect the low side field service coupling to the suction service valve port.
- 4.. Turn the low side field service coupling knob (blue) clockwise, which will open the low side of the system to the gauge set.



## WARNING

**To prevent trapping liquid refrigerant in the manifold gauge set be sure set is brought to suction pressure before disconnecting.**

## c. Removing the Manifold Gauge Set

1. Backseat (turn counterclockwise) the high side (discharge) field service coupling (red knob).
- 2.. Midseat both hand valves on the manifold gauge set and allow the pressure in the manifold gauge set to be drawn down to suction pressure. This returns any liquid that may be in the high side hose to the system.
- 3.. Backseat the low side (suction) field service coupling (red knob) and frontseat (clockwise) both manifold gauge set valves. Remove the couplings from the service ports.
- 4.. Install both service port caps (finger-tight only).

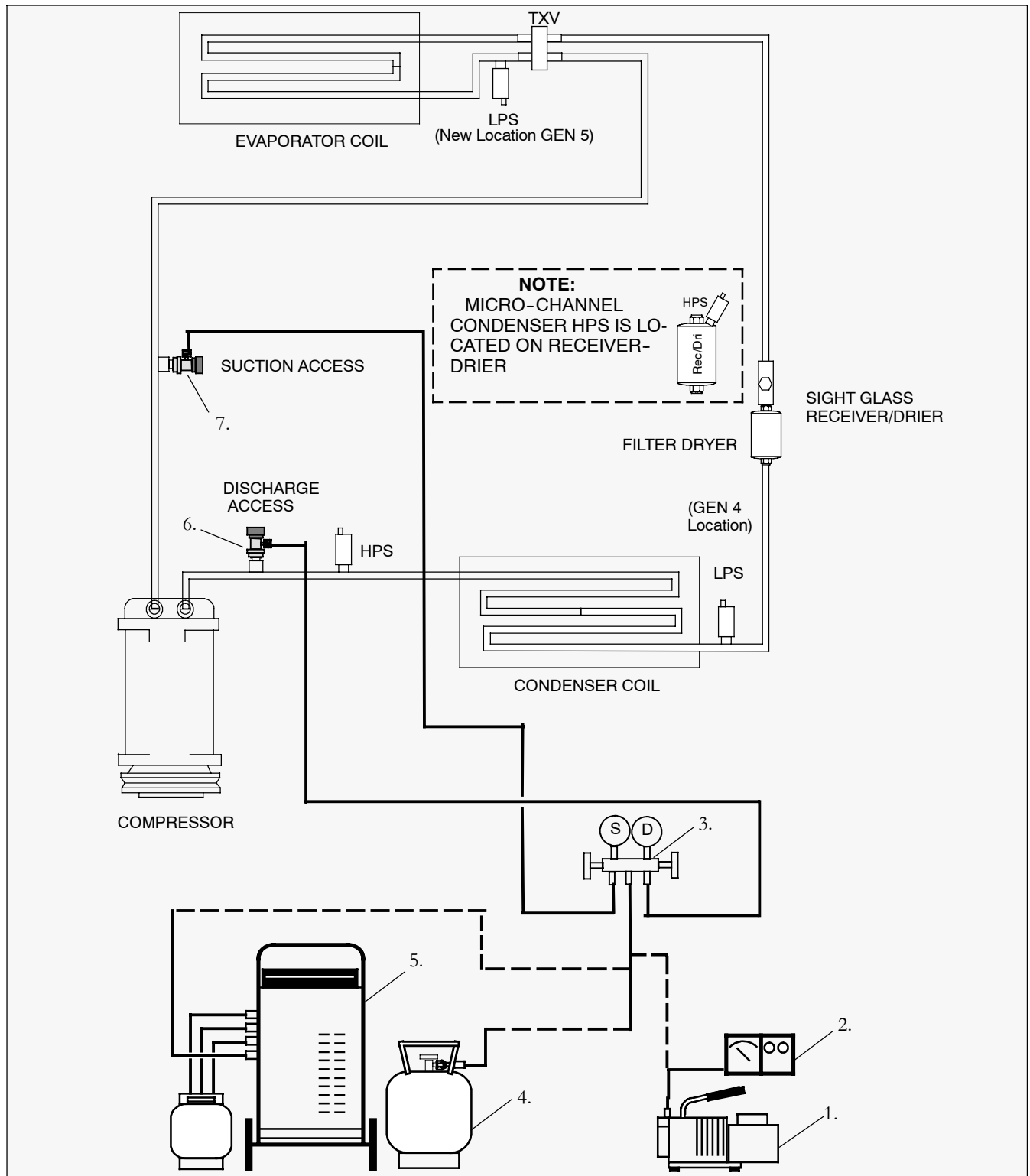

- |                         |  |
|-------------------------|--|
| 1. Vacuum Pump          | 5. Recovery/Recycle Machine            |
| 2. Micron Gauge         | 6. R134a High (Discharge) Side Coupler |
| 3. Manifold Gauge Set   | 7. R134a Low (Suction) Side Coupler    |
| 4. Refrigerant Cylinder |  |

Figure 4-2 Refrigerant Service Connections (Split Systems)



## 4.4 REFRIGERANT RECOVERY

To remove the entire refrigerant charge, do the following:

- a. Connect a manifold gauge set to the system as shown in Figure 4-2.
- b. Connect a reclaimer to the center manifold gauge set connection.
- c. Recover refrigerant in accordance with reclaimer manufacturers instructions.

## 4.5 REFRIGERANT LEAK CHECKING

A refrigerant leak check should always be performed after the system has been opened to replace or repair a component.

To check for leaks in the refrigeration system, perform the following procedure:



### WARNING

**Never use air for leak testing. It has been determined that pressurized, air-rich mixtures of refrigerants and air can undergo combustion when exposed to an ignition source.**

#### Note

Larger split systems may be equipped with service valves and a liquid line solenoid. Ensure these service valves are open and power the liquid line service valve from an external source.

- a. If the system is without refrigerant, charge the system with refrigerant vapor to build up pressure to approximately 30 PSIG (R134a).
- b. Add sufficient nitrogen to raise system pressure to 150/200 psig. (10.21/13.61 bar).
- c. Check for leaks. The recommended procedure for finding leaks in a system is with a R-134a electronic leak detector. Testing joints with soapsuds is satisfactory and may be necessary under conditions where when an electronic leak detector will not function properly, such as with large leaks.
- d. Remove test gas and replace filter-drier.
- e. Evacuate and dehydrate the unit. (Refer to paragraph 4.6.)

- f. Charge the unit. (Refer to paragraph 4.8).

## 4.6 EVACUATION AND DEHYDRATION

### 4.6.1 General

The presence of moisture in a refrigeration system can have many undesirable effects. The most common are copper plating, acid sludge formation, “freezing-up” of metering devices by free water, and formation of acids, resulting in metal corrosion. A triple evacuation (Refer to paragraph 4.6.3) should be performed after a major system repair (compressor, evaporator, or condenser replacement). A one time evacuation (Refer to paragraph ) should take place after a minor system repair, such as a filter-drier replacement.

### 4.6.2 Preparation

#### NOTE

Using a compound gauge for determination of vacuum level is not recommended because of its inherent inaccuracy.

- a. Evacuate and dehydrate only after pressure leak test. (Refer to paragraph 4.5 .)
- b. Essential tools to properly evacuate and dehydrate any system include a vacuum pump (6 cfm volume displacement - (MCC P/N 07-00176-11) and an electronic vacuum (micron) gauge (MCC P/N 07-00414-00).
- c. Keep the ambient temperature above 60° F (15.6° C) to speed evaporation of moisture. If the ambient temperature is lower than 60° F (15.6° C), ice may form before moisture removal is complete. Heat lamps or alternate sources of heat may be used to raise the system temperature.



### 4.6.3 Procedure For Evacuation and Dehydrating System (Triple Evacuation)

- a. Remove all refrigerant using a refrigerant recovery system (Refer to paragraph )
- b. The recommended method is connecting lines (3/8" refrigerant hoses designed for vacuum service) as shown in Figure 4-2.
- c. Make sure vacuum pump valve is open.
- d. Start the vacuum pump. Slowly open valves halfway and then open vacuum gauge valve.
- e. Evacuate unit until vacuum gauge indicates 2000 microns (Hg vacuum). Close gauge valve, vacuum pump valve, and stop vacuum pump.
- f. Break the vacuum with nitrogen. Raise system pressure to approximately 2 psig (0.14 bar).
- g. Purge the nitrogen from the system.
- h. Repeat steps d. thru f. one time.
- i. Start vacuum pump and open all valves. Dehydrate system to 500 microns (Hg vacuum).
- j. Close off pump valve, and stop pump. Wait 5 minutes to see if vacuum holds.
- k. Charge system. Refer to paragraph 4.8.

### 4.7 PROCEDURE FOR EVACUATION AND DEHYDRATING SYSTEM (ONE TIME EVACUATION)

- a. Remove all refrigerant using a refrigerant recovery (reclaimer) system (Refer to paragraph 4.4)
- b. The recommended method is connecting lines (3/8" refrigerant hoses designed for vacuum service) as shown in Figure 4-2.
- c. Make sure vacuum pump valve is open.
- d. Start the vacuum pump. Slowly open valves halfway and then open vacuum gauge valve.
- e. Evacuate unit until vacuum gauge indicates 500 microns (Hg vacuum). Close gauge valve, vacuum pump valve, and stop vacuum pump.
- f. Close off pump valve, and stop pump. Wait 5 minutes to see if vacuum holds.
- g. Charge system. Refer to paragraph 4.8.

## 4.8 ADDING REFRIGERANT TO A SYSTEM

### 4.8.1 Checking Refrigerant Charge

The following conditions must be met to accurately check the refrigerant charge.

- a. Bus engine operating at high idle.

- b. Air conditioning system operating in high cool 10 to 15 minutes.
- c. Compressor discharge (head) pressure a minimum of 150 psig with R134a. It may be necessary to block condenser air flow to raise discharge pressure.
- d. On the large split systems that are equipped with a liquid line receiver, the system is properly charged when the refrigerant level is at 1/2 to 3/4 of the receiver sight glass. If it is not at the proper level, add or remove refrigerant to bring it to the proper level.
- e. On the smaller split systems refer to Table 4-5 to determine if correct charge has been obtained.

### 4.8.2 Adding Full Charge

- a. Install manifold gauge set at the suction and discharge service valves. See Figure 4-2.
- b. Evacuate and dehydrate system. (Refer to paragraph 4.6).
- c. Place R134a refrigerant cylinder on scales.
- d. Calculate the approximate refrigerant charge using either Table 4-1, Table 4-2 or Table 4-3. Open the liquid valve on refrigerant cylinder. Open the discharge line service port coupler and allow refrigerant to flow into the unit until the correct weight of refrigerant has been added as indicated by scales.
- e. Backseat discharge service coupler (to close off gauge port). Close liquid valve on cylinder.
- f. Start unit in cooling mode. Run approximately 10 minutes and check the refrigerant charge. (Refer to paragraph 4.8.1)

### 4.8.3 Adding Partial Charge

- a. Examine the unit refrigerant system for any evidence of leaks. Repair as necessary. (Refer to paragraph 4.5.)
- b. Maintain the conditions outlined in paragraph 4.8.2.
- c. Connect charging line between suction service port and cylinder of refrigerant R-134a. Open VAPOR valve.
- d. Slowly add charge as required. Refer to Table 4-5.



## 4.9 COMPRESSOR(S)

If the compressor(s) is inoperative and the system still has refrigerant pressure, recover the refrigerant with an approved recovery/recycle machine before attempting repair and/or replacement of the compressor.

Always ensure the replacement compressor has the correct amount of oil as specified by the manufacturer.

Approximate oil charges:

A-6 - - - 10 Fluid Ounces

TM-16 - - 6.08 Fluid Ounces (180CC)

TM-21 - - 8 Fluid Ounces

TM-31 - 16.9 Fluid Ounces



## CAUTION

**Unless there was a catastrophic failure, such as a blown or ruptured refrigerant hose, additional oil may not be needed.**

Refer to the specific compressor manufacturer's service manual for proper maintenance and handling procedures for the compressor installed on your vehicle.

## NOTE

Mobile Climate Control does not recommend chemical flushing of the refrigeration system. If required, flushing is to be performed using the system refrigerant.





**Table 4-1 Split System Refrigerant And Oil Charging Table - Thru GEN 4**

| Evaporator<br>Up to GEN V | Condenser<br>All Series | Recommended<br>R134a Charge | Recommended<br>Oil Charge* |
|---------------------------|-------------------------|-----------------------------|----------------------------|
| EM-1, EM-2, or EM-9       | CM-2                    | 5.00 Pounds                 | 10.0 Ounces                |
| EM-1, EM-2, or EM-9       | CM-11                   | 5.25 Pounds                 | 10.5 Ounces                |
| EM-6                      | CM-2                    | 4.00 Pounds                 | 8.0 Ounces                 |
| EM-6                      | CM-11                   | 4.25 Pounds                 | 8.5 Ounces                 |
| EM-1, EM-2, or EM-9       | CM-3                    | 5.50 Pounds                 | 11.0 Ounces                |
| EM-1, EM-2, or EM-9       | CM-7                    | 6.50 Pounds                 | 13.0 Ounces                |
| EM-3                      | (2) CM-2                | 4.25 Pounds Each            | 8.5 Ounces Each            |
| EM-3                      | (2) CM-11               | 4.25 Pounds Each            | 8.5 Ounces Each            |
| EM-3                      | (2) CM-3                | 5.50 Pounds Each            | 11.0 Ounces Each           |
| EM-3                      | (2) CM-7                | 6.25 Pounds Each            | 12.5 Ounces Each           |
| EM-14                     | CM-2                    | 3.50 Pounds                 | 7.0 Ounces                 |
| EM-14                     | CM-11                   | 3.75 Pounds                 | 7.5 Ounces                 |
| EM-17                     | CM-5                    | 19.0 Pounds                 | Consult Factory            |
| EM-17                     | KR-4                    | 13.0 Pounds                 | Consult Factory            |

**Table 4-2 SPLIT SYSTEM REFRIGERANT AND OIL CHARGING TABLE (GEN-5)**

| Evaporator<br>GEN 5 | Condenser<br>All Series | Recommended<br>R134a Charge | Recommended<br>Oil Charge* |
|---------------------|-------------------------|-----------------------------|----------------------------|
| GEN 5 - EM-1        | CM-2 or CM-4            | 4.75 Pounds                 | 9.5 Ounces                 |
| GEN 5 - EM-1        | CM-11                   | 5.00 Pounds                 | 10.0 Ounces                |
| GEN 5 - EM-1        | CM-3                    | 5.25 Pounds                 | 10.5 Ounces                |
| GEN 5 - EM-1        | CM-7                    | 6.25 Pounds                 | 12.5 Ounces                |
| GEN 5 - EM-7        | CM-2 or CM-4            | 4.00 Pounds                 | 8.0 Ounces                 |
| GEN 5 - EM-7        | CM-11                   | 4.25 Pounds                 | 8.5 Ounces                 |
| GEN 5 - EM-2        | CM-2 or CM-4            | 4.50 Pounds                 | 9.0 Ounces                 |
| GEN 5 - EM-2        | CM-11                   | 4.75 Pounds                 | 9.5 Ounces                 |
| GEN 5 - EM-2        | CM-3                    | 5.00 Pounds                 | 10.0 Ounces                |
| GEN 5 - EM-2        | CM-7                    | 6.00 Pounds                 | 12.0 Ounces                |

**Table 4-3 SPLIT-SYSTEM GEN-5 WITH MICRO-CHANNEL CONDENSER**

| Evaporator       | Condenser<br>Micro-Channel | Recommended<br>R134a Charge | Recommended<br>Oil Charge |
|------------------|----------------------------|-----------------------------|---------------------------|
| EM-1, EM-9, IW-1 | CM-2                       | 3.25 Pounds                 | 6.5 Ounces                |
| EM-1, EM-9, IW-1 | CM-3                       | 3.75 Pounds                 | 7.5 Ounces                |
| EM-2, IW-2       | CM-2                       | 3.00 Pounds                 | 6.0 Ounces                |
| EM-2, IW-2       | CM-3                       | 3.50 Pounds                 | 7.0 Ounces                |
| EM-7, IW-14      | CM-2                       | 2.75 Pounds                 | 5.0 Ounces                |
| EM-7, IW-14      | CM-3                       | 3.00 Pounds                 | 6.0 Ounces                |
| EM-3 (dual loop) | (2) CM-3                   | 4.50 Pounds (each)          | 9.0 Ounces (each)         |

**NOTE**

Micro-Channel Style Condensers (See Figure 4-1) will require 1-1/2 to 2 lbs less charge than standard condenser assemblies.





Figure 4-1 Micro-Channel Style Condenser Assembly

The data listed in Table 4-1 through Table 4-3 is based on a 20 foot liquid line. Increase the charge by 0.5 pound for each additional 10 feet of liquid line.

After determining the *approximate charge* using the above tables, refer to “System Performance Chart” (Table 4-5) to determine if the correct charge has been obtained.

#### 4.9.1 Evaporator Tie-In

When an after market in-dash evaporator is added to a standard system the refrigerant charge will increase by approximately 1 pound.

If attempting to use a CM-2 condenser with a tie-in call Mobile Climate Control technical support for an application review.

#### NOTE

The above chart is based on a 20 foot liquid line. Increase the charge by 0.5 pound for each additional 10 feet of liquid line.

When an after market evaporator or in-dash evaporator is added to a standard system the refrigerant charge will increase by approximately 1 pound.

If attempting to use a CM-2 condenser with a tie-in call Mobile Climate Control technical support for an application review.

Table 4-4 Compressor Oil Type & Part Numbers

| Manufacturer                          | Oil Type | CTAC Part Number |
|---------------------------------------|----------|------------------|
| Seltec - Valeo - ICE - Zexel - Sanden | PAG      | 46-50006-00      |
| Alma (A-6)                            | PAG      | 46-50004-00      |
| 05G & 05K Bus & 06D                   | POE      | 46-50008-00      |



Use only the exact oil specified by Mobile Climate Control. Use of oil other than that specified will void the compressor warranty.



**Table 4-5 Mobile Climate Control SYSTEM PERFORMANCE CHART**

Determine the approximate refrigerant charge using Table 4-1, Table 4-2 or Table 4-3 .

Use the following table to determine if the correct charge has been obtained.

| Table    |                   |       | Procedure  | Your Entry                     | Example                      |
|----------|-------------------|-------|--|--------------------------------|------------------------------|
| Pressure | Refrigerant Temp. |       | 1. Connect Manifold Gauge Set To Air Conditioning System   | NONE                           | NONE                         |
| PSIG     | R-12              | R134a |  |                                |                              |
| (A)      | (B)               | (C)   |  |                                |                              |
| 95       | 87                | 85    | 2. Measure outside (ambient) air temperature.<br>Enter here ----->   | ____ Degrees F                 | 100 Degrees F                |
| 100      | 90                | 88    |  |                                |                              |
| 105      | 93                | 90    |  |                                |                              |
| 110      | 96                | 93    |  |                                |                              |
| 115      | 99                | 96    |  |                                |                              |
| 120      | 102               | 98    | 3. Add 40 degrees F to the outside (ambient) air temperature ---><br><br><b>Note:</b> If using a Micro-channel style condenser, use 37 degrees F instead of 40. This is due to the reduced discharge pressure associated with this type of application.  | 40 Degrees F<br>____ Degrees F | 40 Degrees F = 140 Degrees F |
| 125      | 104               | 100   |  |                                |                              |
| 130      | 107               | 103   |  |                                |                              |
| 135      | 109               | 105   |  |                                |                              |
| 140      | 112               | 107   |  |                                |                              |
| 145      | 114               | 109   | 4. Find closest refrigerant temperature in Table (B or C) and enter here ---->   | ____ Degrees F                 | 139 Degrees F                |
| 150      | 117               | 112   |  |                                |                              |
| 155      | 119               | 114   |  |                                |                              |
| 160      | 121               | 116   |  |                                |                              |
| 165      | 123               | 118   |  |                                |                              |
| 170      | 126               | 120   | 5. Going across the Table, find the corresponding pressure (A) -->   | (D)= _____ PSI                 | 225 PSI                      |
| 175      | 128               | 122   |  |                                |                              |
| 180      | 130               | 123   |  |                                |                              |
| 185      | 132               | 125   |  |                                |                              |
| 190      | 134               | 127   |  |                                |                              |
| 195      | 136               | 129   | 6. If the Discharge Pressure (High Side) on gaugers (With compressor engaged, engine speed 1200 RPM, and system operating) is :<br><br>Greater than (D) - Reduce refrigerant by 4 ounce increments.<br><br>Less than (D) - Add refrigerant<br><br>Wait 10 minutes for system to stabilize before taking new readings | ***                            | ***                          |
| 200      | 138               | 131   |  |                                |                              |
| 205      | 140               | 132   |  |                                |                              |
| 210      | 142               | 134   |  |                                |                              |
| 215      | 143               | 136   |  |                                |                              |
| 220      | 145               | 137   |  |                                |                              |
| 225      | 147               | 139   |  |                                |                              |
| 235      | 150               | 142   |  |                                |                              |
| 245      | 154               | 145   |  |                                |                              |
| 255      | 157               | 148   |  |                                |                              |
| 265      | 160               | 151   |  |                                |                              |
| 275      | 163               | 153   |  |                                |                              |



**Table 4-6 STANDARD TORQUE REQUIREMENTS**

| SIZE | TUBE O.D. *     | FLARE          | O-RING         |                | THREAD ** |
|------|-----------------|----------------|----------------|----------------|-----------|
|      |                 |                | STEEL TUBING   | ALUM. TUBING   |           |
| 4    | 1/4 inch (.250) | 11-13 ft./lbs. | 30-35 ft./lbs. | 5-7 ft./lbs.   | 7/16      |
| 5    | 3/8 inch (.375) | 15-17 ft./lbs. | 30-35 ft./lbs. | 8-10 ft./lbs.  | 9/16      |
| 6    | 3/8 inch (.375) | 18-20 ft./lbs. | 30-35 ft./lbs. | 11-13 ft./lbs. | 5/8       |
| 8    | 1/2 inch (.500) | 36-39 ft./lbs. | 30-35 ft./lbs. | 15-20 ft./lbs. | 3/4       |
| 10   | 5/8 inch (.625) | 52-57 ft./lbs. | 30-35 ft./lbs. | 21-27 ft./lbs. | 7/8       |
| 12   | 3/4 inch (.750) | 71-79 ft./lbs. | 30-35 ft./lbs. | 28-33 ft./lbs. | 1-1/16    |

\* The tube O.D. is measured at the point it passes through the nut. \*\* Thread pitch may vary.

**4.10 TORQUE SPECIFICATIONS - REFRIGERANT FITTINGS**

All refrigerant hose fitting connections must be torqued to the specifications listed in Table 4-6.

**NOTE**

No matter what type of lubricant (oil) used in the system, always use mineral oil to lubricate the O-Rings and fittings. PAG oils will absorb moisture and become very acidic and corrosive. Mineral oil absorbs moisture at a much lower rate than PAG oils.

**Table 4-8 U.S. Torque Specs**

| Bolt Size Dia. mm | Torque (Ft-Lb) Cast Iron Grade 2 | Torque (Ft-Lb) Cast Iron Grade 5 | Torque (Ft-Lb) Cast Iron Grade 8 |
|-------------------|----------------------------------|----------------------------------|----------------------------------|
| 1/4-20            | 5                                | 7                                | 11                               |
| 5/16-18           | 10                               | 15                               | 22                               |
| 3/8-16            | 18                               | 30                               | 40                               |
| 7/16-14           | 30                               | 45                               | 65                               |
| 7/16-20           | 32                               | 50                               | 70                               |
| 1/2-13            | 45                               | 70                               | 95                               |
| 1/2-20            | 50                               | 75                               | 110                              |
| 5/8-11            | 82                               | 135                              | 190                              |
| 5/8-18            | 93                               | 155                              | 215                              |

**4.11 TORQUE SPECIFICATIONS - BOLTS**

The torque values listed in Table 4-7 and Table 4-8 are based on the use of lubricated threads.

**Table 4-7 Metric Torque Specs**

| Bolt Size Dia. mm | Torque (Ft-Lb) Cast Iron Grade 8.8 | Torque (Ft-Lb) Cast Iron Grade 10.9 | Torque (Ft-Lb) Cast Iron Grade 12.9 |
|-------------------|------------------------------------|-------------------------------------|-------------------------------------|
| 6                 | 7                                  | 9                                   | 9                                   |
| 7                 | 10                                 | 13                                  | 18                                  |
| 8                 | 18                                 | 23                                  | 27                                  |
| 10                | 30                                 | 45                                  | 50                                  |
| 12                | 55                                 | 75                                  | 95                                  |
| 14                | 85                                 | 120                                 | 145                                 |
| 16                | 130                                | 175                                 | 210                                 |

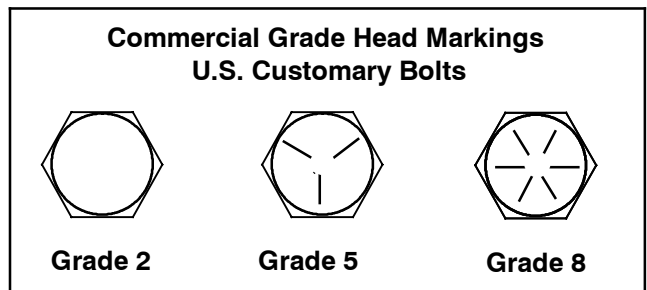

**Figure 4-4 U.S. Bolt Markings**

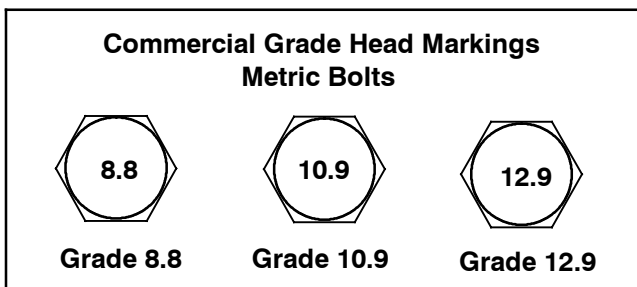

**Figure 4-3 Metric Bolt Markings**

**4.11.1 Electrical Control Panel - Torque Values**

Torque values for all Split-System electrical panels are as follows.

1. Torque value for wire connections at the plastic circuit breakers are: **24 In-Lbs max.**
2. Plastic Breaker mounting screw torque is: **15 In-Lbs.**
3. Torque value for wire connections at the plastic terminal strip are: **25 In-Lbs max.**
4. Terminal Strip mounting screws are: **25 In-Lbs max.**

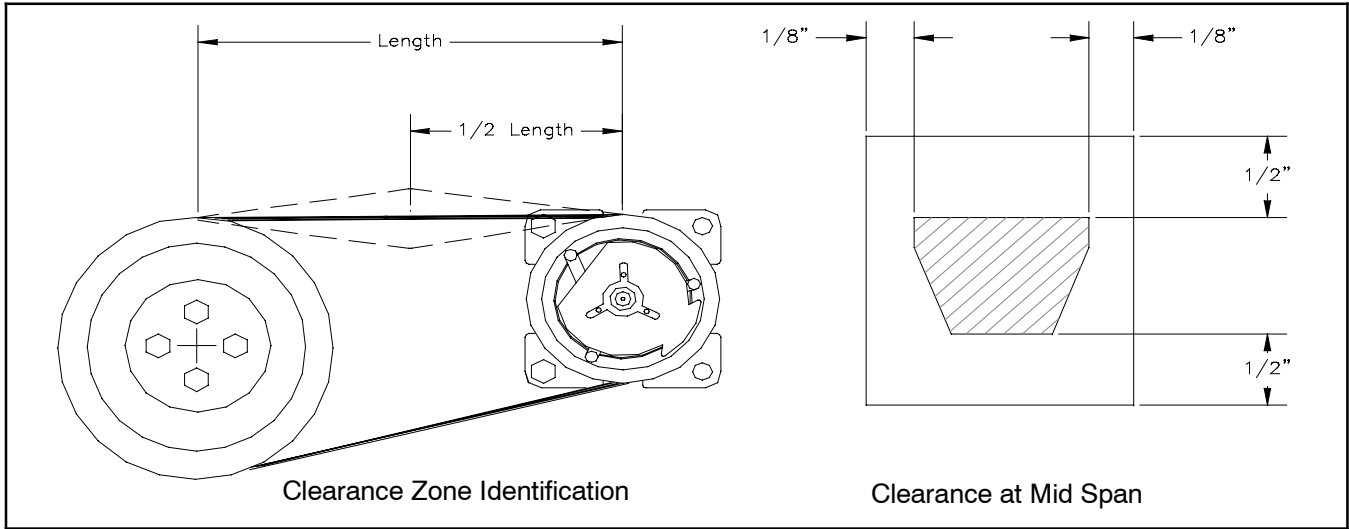

Figure 4-5 Belt Clearance Requirements

## 4.12 DRIVE BELT INSTALLATION

### 4.12.1 Introduction

There are several factors that have major effects on compressor and alternator drive belt(s) life expectancy and reliability. Belt alignment and proper tension being the most critical and controllable by the installer and end-user. Improper alignment and/or tension will cause premature failure of drive belts, driven components as well as a possible safety issue. When improperly installed and/or maintained, drive belts can cause significant damage to equipment. The following are the biggest factors that effect belt life and system dependability.

- A. Belt Alignment
- B. Belt Tension
  - 1. Over Tensioned
  - 2. Under Tensioned
- C. Belt Clearance
- D. Temperature-Heat
- E. Fluids
- F. Maintenance Procedures

### 4.12.2 Belt Clearance

A certain belt clearance needs to be maintained for belt span vibration when installing compressors and alternator belts. Figure 4-5 shows the recommended guidelines for clearance. Due to the large number of variables, actual testing is required to determine whether the clearances are acceptable.

### 4.12.3 Pulley Alignment

Correct belt alignment is essential for alternator and compressor belt life. The center line of all pulleys related to compressor or alternator drive must be within 1/3 degree of true center. Refer to Figure 4-6 for approximate measurements, and keep in mind, these are maximum values. You should try to attain perfect alignment whenever possible to maximize component and belt life.

Maximum allowable run-out for Poly "V" belts is 1/8 inch.

Maximum allowable run-out for Standard "V" belts is 1/4 inch.

Alignment methods are illustrated in Figure 4-6 and Figure 4-7. A high quality straight edge is a necessity, your eye is not an acceptable method of determining proper belt alignment. All mounting brackets should allow for minor belt center line adjustments.

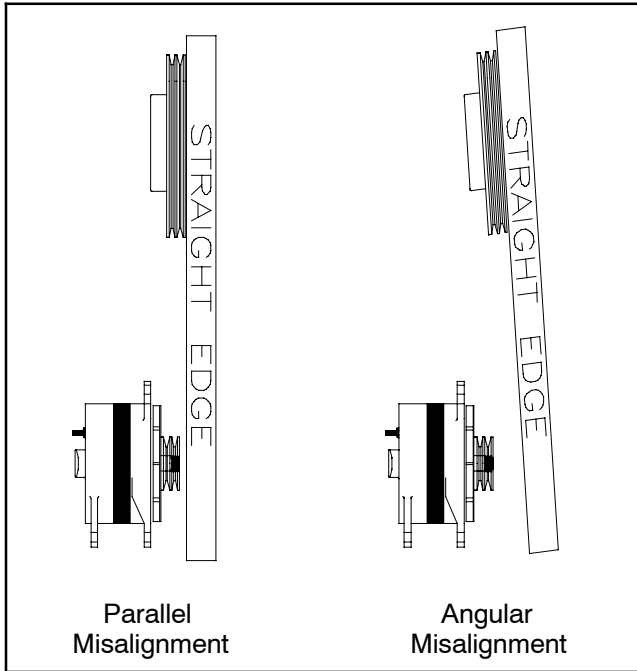

**Figure 4-6 Belt Misalignment**

Parallel adjustment is designed into a mount for final alignment during the installation process. Parallel misalignment is corrected by moving the driven pulley (alternator or compressor) into alignment with the drive pulley. This can be done using several methods. Spacing the component forward or rearward by adding or removing spacers is the most popular method used to achieve proper alignment. Other methods such as sliding the component forward or rearwards using slide plates and/or slots in the main weldment are also used.

Angular misalignment is often caused by tolerances in several pieces, such as hardware to mounting holes and plates to components. Angular misalignment is corrected by loosening the mounting hardware, adjusting the compressor/alternator to the proper angle and retightening the mounting hardware.

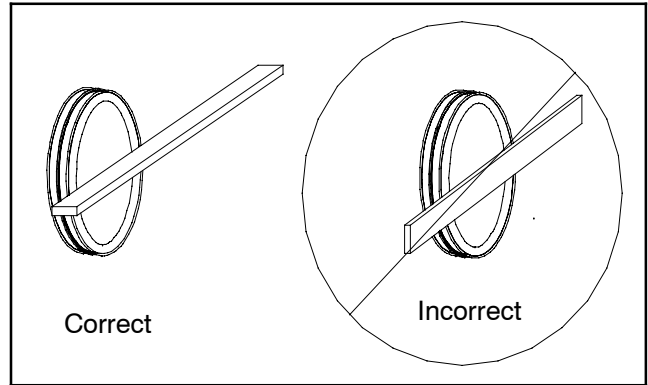

**Figure 4-7 Straight-Edge Application**

Proper use of a straight edge is illustrated in Figure 4-7 . Never use a straight edge on the wide/flat side, as they are not accurate. The thin edge is a straight surface and the only accurate surface. The straight edge must be flush across the face of the pulley. Then, to measure the alignment, lower the other end down to the driven pulley(s). Adjustments are made based on results of the aforementioned. Note that the pulley rim width must be considered when making the aforementioned measurements.

The next step is to lay the straight edge flush across the face of the driven pulley. This is the best way to determine angular misalignment. Again, adjust as required. You should repeat this step for all pulleys until acceptable alignment is achieved. Note the drive pulley is the primary guide for alignment. Do not use idlers as a guide for proper component belt alignment as bearing play could give you false readings.

**4.12.4 Drive Belt Tension Guidelines**

Proper belt tension is essential for not only belt life, but also the alternator and compressor life as well. Heat is a major enemy of compressors and alternators that can cause unnecessary stress and greatly reduce component life.

Listed in Table 4-9 are the examples specific to belt tension concerns:

- A.** Under tension would promote belt slippage causing excessive heat. Heat equals premature alternator and/or compressor failure.
- B.** Over tension could cause premature bearing failure and excessive wear on drive and driven components.

Proper belt tension is obtained by referring to Table 4-9. Find the belt used and where applied (compressor or alternator drive, Single "V" or Ploy "V" 4-8 ribs).



Notice that new belt tension is higher than in-service or re-tension amount. All new belts require a run-in period. During this period, a new belt will stretch more in a 10 hour run time than the entire life of the belt. So it is important to recheck belt tension after run-in or re-tension new belts if less than re-tension amount prescribed above. You should check belt tension with the belt "hot." However, the belt must be allowed to cool before re-tensioning. Drives which incorporate automatic tensioners do not require a run-in period or re-tensioning.

4.12.5 Measuring Methods for Belt Tension

There are several methods and tools available for determining belt tension. The industry's acceptable method would be to use a belt tension gauge as manufactured by Burroughs or approved equal. There are also several models available than can be used. Please follow manufacturer guidelines regarding gauge selection operation and calibration requirements. You must get the correct tension gauge for your specific belt type(s).

4.13 RETURN AIR FILTER

NOTE

Never operate the evaporator without the return-air filter properly installed.

The evaporator return air filter(s) should be checked for cleanliness periodically(refer to table 4.1) and always with regard to operating conditions. A system operating on unpaved dusty roads will need a stricter maintenance schedule than a bus operating consistently on paved roads. A dirty air filter will restrict the air flow over the evaporator coil. This could cause insufficient cooling or heating and possible frost build-up on the coil. The GEN 4 series return air filters are secured to the rear of the evaporator coil assembly, while the GEN 5 series return air filters are located under the evaporator cover assembly.

Table 4-9 Belt Tension Guide

| Drive                            | Belt Top Width | New Belt Lbs. Tension | Re-Tension Lbs. Tension | Re-Tension Threshold |
|----------------------------------|----------------|-----------------------|-------------------------|----------------------|
| Alternator                       | All            | 110                   | 90                      | 70                   |
| Compressor                       | All            | 130                   | 105                     | 80                   |
| Poly-Rib Belt & Serpentine Drive | 6 or More Ribs | 145                   | 105                     | 90                   |

4.13.1 GEN 4 (EXCEL) Series

Replace the GEN 4 series return air filter(s) as follows:

- a. Remove the evaporator return air grill.
- b. Remove the return air filter from behind the coil assembly.
- c. With the return air filter(s) and return air grill removed, it is advisable to check the evaporator coil. If the coil is dirty proceed with cleaning the coil.
- d. Clean or replace the return air filter(s).
- e. Replace evaporator return air grill.

4.13.2 GEN 5 Series

Replace the GEN 5 series return air filter(s) as follows:

- a. Insert a 3mm Allen wrench into the 1/4 turn receptacle stud.
- b. Turn counterclockwise opening the filter channel.
- c. Slide filter out of the evaporator grill. (In some applications, needle-nosed pliers may be needed in order to grip the filter assembly).
- d. Clean or replace the return air filter(s) as required.
- e. Close the filter channel and lock the 1/4 turn stud into place by turning clockwise with 3mm Allen wrench.





### 4.14 EVAPORATOR BLOWER AND/OR MOTOR ASSEMBLY

#### 4.14.1 GEN 4 Series

Replace the blower motor assembly as follows:

- a. Disconnect bus battery.
- b. Pop-off the snap cap covers and remove all screws holding the cover to the unit assembly. Remove the evaporator cover.
- c. Remove drain hoses from drain pan assembly.
- d. Remove hardware securing drain pan to the evaporator assembly (4 places).
- e. Supporting the blower motor assembly, remove the hardware that secures the blower motor assembly to the evaporator. (4 places).
- f. Unplug the motor from the evaporator wiring harness.
- g. Replace as necessary.
- h. Reinstall blower motor assembly reversing steps a. thru f.
- i. Check blower motor assembly operation.

#### 4.14.2 GEN 5 Series

Replace the blower wheel and/or motor as follows:

- a. Disconnect bus battery.
- b. Pop-off the snap cap covers and remove all screws holding the cover to the unit assembly. Remove the evaporator cover
- c. Disconnect the red and black wire from the terminal block.
- d. Using a 1/8 inch (EM-1 only) or 3/32 inch (EM-2/3/7) Allen handle loosen the set screw securing the motor shaft to the blower wheel. The set screw can be accessed through a notched fin in the blower wheel.
- e. Remove hardware (4 places) securing the motor strap to the top panel.
- f. Remove motor strap and motor gasket from motor assembly.
- g. Slide motor assembly shaft out of blower wheel.
- h. Pull blower wheel assembly from bearing cup.
- i. Replace motor and/or blower wheel if necessary.
- j. Carefully place blower wheel assembly into the bearing cup.

- k. Insert motor shaft into the blower wheel hub.
- l. Align blower wheel set screw to flat spot on motor shaft and tighten.
- m. Continue to reassemble by reversing steps a. thru f.
- n. Check motor and blower wheel operation.

### 4.15 RESISTORS

#### 4.15.1 GEN 4 Series (Excel)

Low, Medium, High, and High Performance speeds (for ducted systems) on the GEN 4 series of evaporators are controlled by the speed selection switch located on the drivers control panel. High (orange wire) or High Performance ducted (black wire) speed is determined at time of installation. See Figure 2-2 for wire connections and Section 5 Electrical for appropriate wiring diagram. Every GEN 4 series evaporator blower motor assembly has a speed control resistor. See Figure 4-8 for wire color connections (speed control) and Ohm's between prongs.

Total resistance rating of the 4-prong resistor is 1.8 Ohm with a  $\pm 5\%$  tolerance rating. Total wattage is 115.

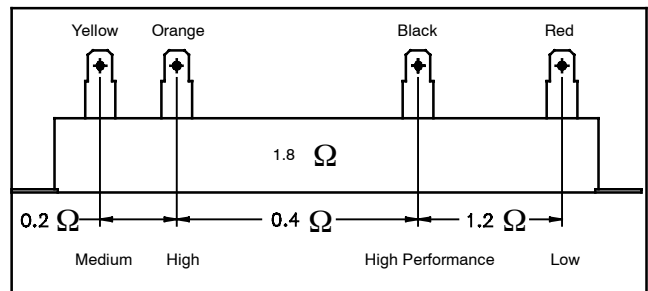

Figure 4-8 GEN 4 Series Resistor Assembly

#### 4.15.2 GEN 5 Series

GEN 5 evaporator motor speeds can be controlled by the driver three ways:

1. Standard GEN 4 type operation using the 3 speed switch and resistors.
2. Variable speed switch control.
3. Electronic Total Control.

Refer to Section 2, GEN 5 Operating Instructions and Section 5, Electrical, for the appropriate GEN 4/5 wiring diagram.



**NOTE**

If evaporator fan motor is only functioning in 1 or 2 of the 3 speeds, the resistor is bad, not the fan motor.

**4.16 CONDENSER FAN ASSEMBLY**

Condenser fan assemblies for GEN 4 and GEN 5 are identical in function and fit. Replace a condenser fan assembly as follows:

- a. Disconnect bus battery.
- b. While supporting both parts, remove hardware (4 places) securing the fan guard and condenser fan assembly to the condenser venturi.
- c. Un-plug fan assembly from condenser harness.
- d. Repair or replace as necessary.
- e. Reassemble by reversing steps a. thru c.
- f. Check condenser fan assembly operation.

**4.17 REPLACING THERMOSTATIC BLOCK VALVE**

The Thermostatic Block Valve is an automatic device which regulates the flow of refrigerant into the evaporator coil. Properly operating it will also prevent liquid refrigerant from returning to the compressor. If the valve is defective, it must be replaced.

- a. Disconnect bus battery.
- b. Recover refrigerant from air conditioning system.
- c. Pop-off the snap cap covers and remove all screws holding the cover to the unit assembly. Remove the evaporator cover .
- d. Remove no-drip insulating tape from block valve and fitting connections.
- e. Carefully loosen fittings connected to the block valve.



**WARNING**

**There may be liquid refrigerant trapped behind the block valve. Slowly loosen the fitting and avoid contact with exposed skin or eyes.**

- f. Remove and replace block valve, lubricating the fittings with mineral oil before torquing to required specifications (Refer to paragraph 4.10).

**NOTE**

Do not attempt to adjust the replacement block valve. Valves are preset at the factory.

- g. Insulate block valve with no-drip insulating tape.
- h. Leak check and evacuate per paragraphs 4.5 & 4.6.
- i. Charge system with the recovered refrigerant.
- j. Check operation of the system. Adjust refrigerant charge as needed.

**4.18 CHECKING AND REPLACING HIGH PRESSURE SWITCH**

**4.18.1 Replacing High or Low Pressure Switch**

- a. The high and low pressure switches are equipped with schrader valve to allow removal and installation without pumping the unit down.
- b. Disconnect wiring from defective switch.
- c. Install new cutout switch after verifying switch settings. (Refer to paragraph 4.18.2)

**4.18.2 Checking High Pressure Switch**



**WARNING**

**Do not use a nitrogen cylinder without a pressure regulator. Do not use oxygen in or near a refrigeration system or as an explosion may occur.**

- a. Remove switch from unit. All units are equipped with schrader valves at the high and low pressure switch connections.





- b. Connect an ohmmeter across switch terminals. If the switch is good, the ohmmeter will indicate no resistance, indicating that the contacts are closed.
- c. Connect switch to a cylinder of dry nitrogen. (See Figure 4-9).

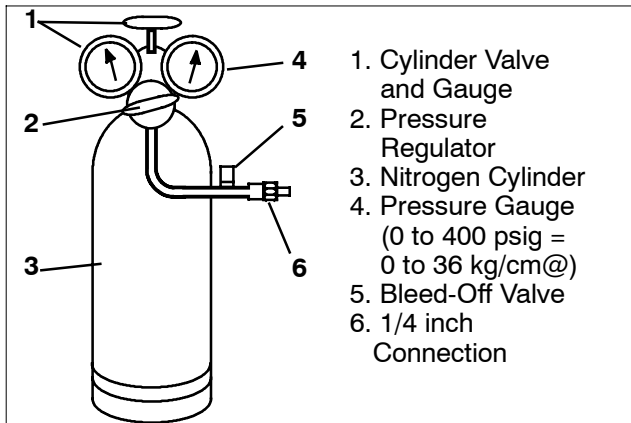

Figure 4-9. Checking High Pressure Switch

- d. Set nitrogen pressure regulator higher than cutout point on switch being tested. (Refer to paragraph 1.7)
- e. Open cylinder valve. Slowly open the regulator valve to increase the pressure until it reaches cutout point. The switch should open, which is indicated by an infinite reading on an ohmmeter (no continuity).
- f. Close cylinder valve and release pressure through the bleed-off valve. As pressure drops to cut-in point, the switch contacts should close, indicating no resistance (continuity) on the ohmmeter.
- g. Replace switch if it does not function as outlined above.

### 4.19 MOISTURE INDICATOR (SYSTEM)

There are two types of moisture indicators presently in use with Mobile Climate Control systems.

**1. Green/Yellow** (Previous Configuration)  
Green = Dry System Yellow = Wet System

**2. Blue/Pink** (Current Configuration)  
Blue = Dry Pink = Wet

### 4.20 FILTER-DRIER OR RECEIVER-DRIER

Mobile Climate Control condensers are supplied with either a filter-drier or a receiver-drier.

### NOTE

All microchannel condenser assemblies are equipped with a receiver-drier with an integral high pressure switch.

If a pressure drop across the Filter-Drier (see Figure 4-10) or Receiver-Drier (see Figure 4-11) is indicated or the moisture-indicator shows an abnormal (wet) condition, the Filter-Drier or Receiver-Drier must be changed.

- a. Check for a restricted filter by touching the filter drier or receiver-drier on inlet and outlet connections. If there is a noticeable temperature difference the filter is probably restricted and should be replaced.
- b. Recover refrigerant, refer to paragraph 4.4.
- c. Place a new filter-drier or receiver-drier near the unit for immediate installation.
- d. Using two open end wrenches, slowly crack open and remove the liquid line O-ring fittings on each side of the filter-drier.



### WARNING

**The filter-drier or receiver-drier may contain liquid refrigerant. Slowly open the fitting nuts and avoid contact with exposed skin or eyes.**

- e. Loosen the hose clamp(s) securing the filter drier or receiver-drier to the condenser assembly.
- f. Remove the filter-drier or receiver drier. Transfer high pressure switch if required.
- g. Remove seal caps from the new filter-drier or receiver-drier. Apply a light coat of mineral oil to the fittings and O-rings.
- h. Assemble the new filter-drier or receiver-drier to the liquid lines ensuring that the arrow on the body of the filter-drier or receiver-drier points in the direction of the refrigerant flow (liquid refrigerant flows from the condenser to the evaporator). Finger tighten the liquid line fittings.
- i. Tighten filter-drier or receiver-drier O-ring fittings using two open end wrenches. Refer to paragraph 4.10 for torque specifications.
- j. Evacuate system to 500 microns by connecting a vacuum pump as shown in Figure 4-2.
- k. Charge system according to paragraph 4.8.2.

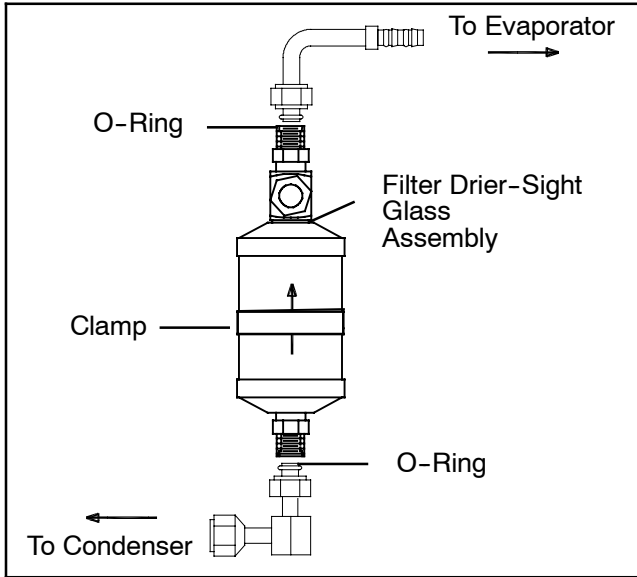

Figure 4-10 Filter Drier

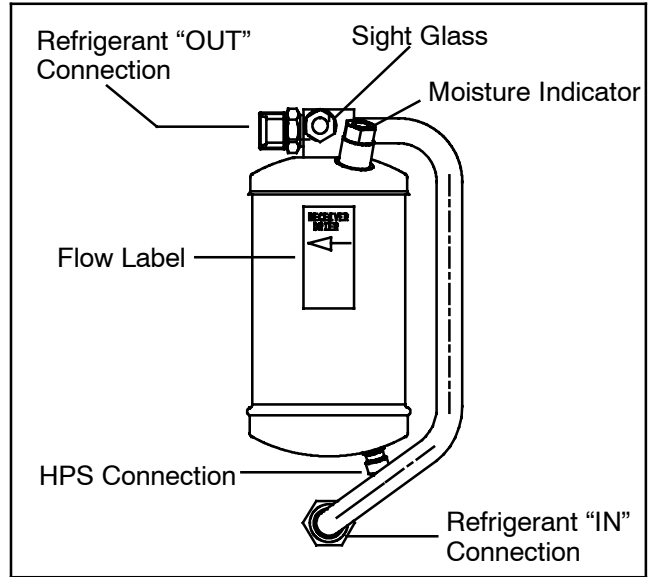

Figure 4-11 Receiver-Drier



Table 4-10 R-134a Temperature - Pressure Chart

| Temperature |     | Vacuum |                    |      |
|-------------|-----|--------|--------------------|------|
| °F          | °C  | PSIG   | Kg/cm <sup>2</sup> | Bar  |
| -40         | -40 | 14.6   | 37.08              | 0.49 |
| -35         | -37 | 12.3   | 31.25              | 0.42 |
| -30         | -34 | 9.7    | 24.64              | 0.33 |
| -25         | -32 | 6.7    | 17.00              | 0.23 |
| -20         | -29 | 3.5    | 8.89               | 0.12 |
| -18         | -28 | 2.1    | 5.33               | 0.07 |
| -16         | -27 | 0.6    | 1.52               | 0.02 |
| -14         | -26 | 0.4    | 0.03               | 0.03 |
| -12         | -24 | 1.2    | 0.08               | 0.08 |
| -10         | -23 | 2.0    | 0.14               | 0.14 |
| -8          | -22 | 2.9    | 0.20               | 0.20 |
| -6          | -21 | 3.7    | 0.26               | 0.26 |
| -4          | -20 | 4.6    | 0.32               | 0.32 |
| -2          | -19 | 5.6    | 0.39               | 0.39 |
| 0           | -18 | 6.5    | 0.46               | 0.45 |
| 2           | -17 | 7.6    | 0.53               | 0.52 |
| 4           | -16 | 8.6    | 0.60               | 0.59 |
| 6           | -14 | 9.7    | 0.68               | 0.67 |
| 8           | -13 | 10.8   | 0.76               | 0.74 |
| 10          | -12 | 12.0   | 0.84               | 0.83 |
| 12          | -11 | 13.2   | 0.93               | 0.91 |
| 14          | -10 | 14.5   | 1.02               | 1.00 |
| 16          | -9  | 15.8   | 1.11               | 1.09 |
| 18          | -8  | 17.1   | 1.20               | 1.18 |
| 20          | -7  | 18.5   | 1.30               | 1.28 |
| 22          | -6  | 19.9   | 1.40               | 1.37 |
| 24          | -4  | 21.4   | 1.50               | 1.48 |
| 26          | -3  | 22.9   | 1.61               | 1.58 |

| Temperature |    | Pressure |                    |       |
|-------------|----|----------|--------------------|-------|
| °F          | °C | Psig     | Kg/cm <sup>2</sup> | Bar   |
| 28          | -2 | 24.5     | 1.72               | 1.69  |
| 30          | -1 | 26.1     | 1.84               | 1.80  |
| 32          | 0  | 27.8     | 1.95               | 1.92  |
| 34          | 1  | 29.6     | 2.08               | 2.04  |
| 36          | 2  | 31.3     | 2.20               | 2.16  |
| 38          | 3  | 33.2     | 2.33               | 2.29  |
| 40          | 4  | 35.1     | 2.47               | 2.42  |
| 45          | 7  | 40.1     | 2.82               | 2.76  |
| 50          | 10 | 45.5     | 3.20               | 3.14  |
| 55          | 13 | 51.2     | 3.60               | 3.53  |
| 60          | 16 | 57.4     | 4.04               | 3.96  |
| 65          | 18 | 64.1     | 4.51               | 4.42  |
| 70          | 21 | 71.1     | 5.00               | 4.90  |
| 75          | 24 | 78.7     | 5.53               | 5.43  |
| 80          | 27 | 86.7     | 6.10               | 5.98  |
| 85          | 29 | 95.3     | 6.70               | 6.57  |
| 90          | 32 | 104.3    | 7.33               | 7.19  |
| 95          | 35 | 114.0    | 8.01               | 7.86  |
| 100         | 38 | 124.2    | 8.73               | 8.56  |
| 105         | 41 | 135.0    | 9.49               | 9.31  |
| 110         | 43 | 146.4    | 10.29              | 10.09 |
| 115         | 46 | 158.4    | 11.14              | 10.92 |
| 120         | 49 | 171.2    | 12.04              | 11.80 |
| 125         | 52 | 184.6    | 12.98              | 12.73 |
| 130         | 54 | 198.7    | 13.97              | 13.70 |
| 135         | 57 | 213.6    | 15.02              | 14.73 |
| 140         | 60 | 229.2    | 16.11              | 15.80 |
| 145         | 63 | 245.6    | 17.27              | 16.93 |
| 150         | 66 | 262.9    | 18.48              | 18.13 |
| 155         | 68 | 281.1    | 19.76              | 19.37 |

## SECTION 5

### ELECTRICAL SCHEMATIC DIAGRAMS

#### 5.1 INTRODUCTION

This section contains Electrical Schematics covering the GEN 4 and GEN 5 systems. Figure 5-3 shows a GEN 4 EM-1 Evaporator with a CM-2/3 Condenser, Figure 5-4 shows a GEN 4 Series EM-1 Evaporator with a CM-2/3 Condenser tied into an OEM compressor, Figure 5-5 shows a GEN 4 EM-3 evaporator with (2) CM-3 condensers, Figure 5-6 shows a (typical) GEN V evaporator with variable speed controls, Figure 5-7 shows a (typical) GEN 5 system with Total Control, Figure 5-8 shows a GEN 4 EM-3 with Total Control, and Figure 5-9 shows a (typical) GEN 4 evaporator (s) with Total Control. Contact your Mobile Climate Control Field Service representative or call Mobile Climate Controls technical hot line at 800-450-2211 for a copy of the schematic for your specific model and/or series.

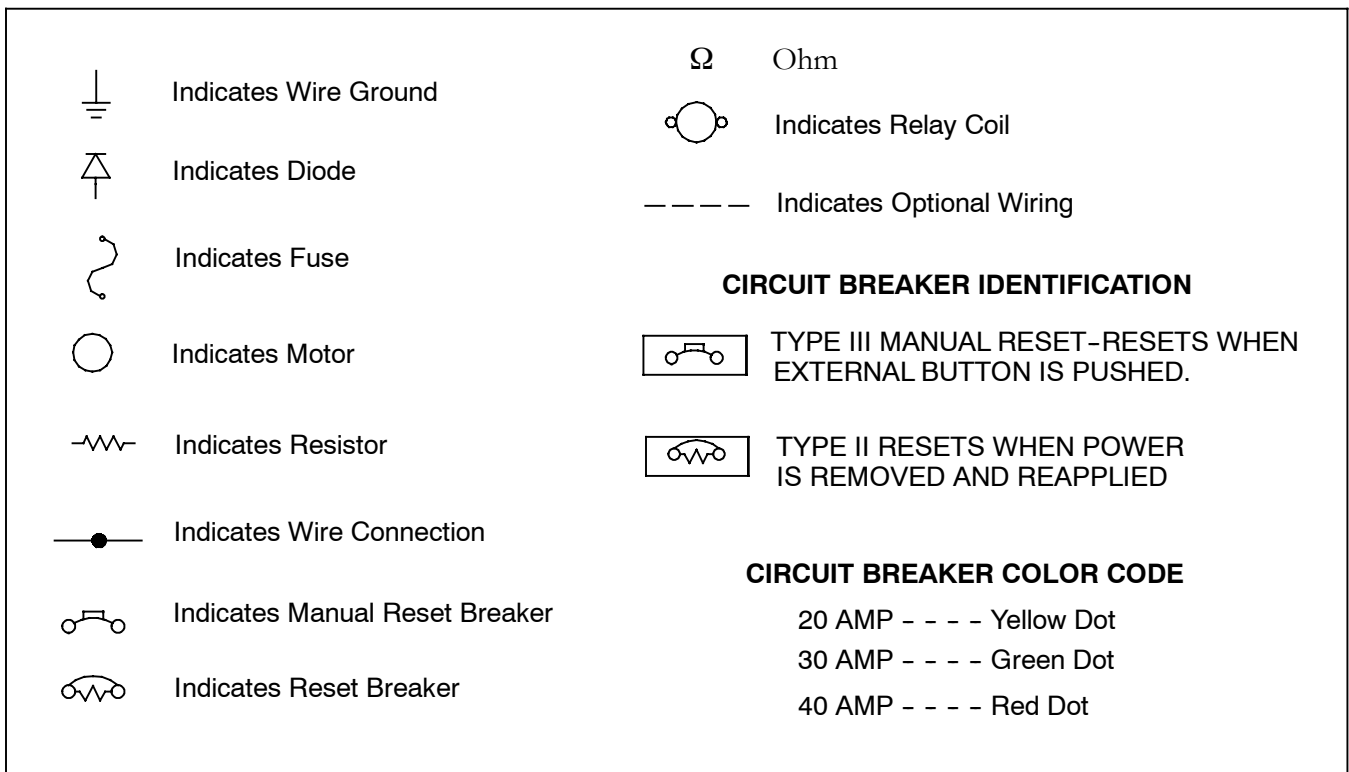

**Figure 5-1 Electrical Schematic Diagram - Symbols**



| LEGEND |   |      |   |
|--------|---|------|---|
| ADJ    | Adjusting   | GRD  | Ground  |
| ALT    | Alternator  | HGS1 | Compressor #2 Relay   |
| AMP    | Ampere  | HGS2 | Heat Valve  |
| AUX    | Load  | HP   | High Pressure Switch  |
| BAT    | Battery   | HP1  | For Grounding of Low Pressure & Frozen Coil Switch For Comp. #1 |
| BP     | Low Pressure & Frozen Coil Switch For Compressor #2 | HP2  | For Grounding of Low Pressure & Frozen Coil Switch For Comp. #2 |
| BPT    | Low pressure & Frozen Coil Switch For Compressor #2 | HSR  | High Speed Relay  |
| BPV    | Fan Speed PWM Signal Output                         | IGN  | Ignition Circuit  |
| CFM    | Condenser Fan Motor                                 | LP   | Low Pressure Switch   |
| CL     | Clutch  | LSR  | Low Speed Relay   |
| CLR    | Clutch Relay  | M    | Motor   |
| CLR2   | Clutch Relay #2                                     | MSR  | Medium Speed Relay  |
| CM     | Condenser Motor                                     | NEIM | (IGN) Tie-In (OEM)  |
| CR     | Condenser Relay                                     | OEM  | Original Equipment Manufacturer                                 |
| EFM    | Evaporator Fan Motor                                | PWM  | Pulse Width Modulation  |
| EM     | Evaporator Module                                   | RAS  | Return Air Sensor   |
| G 4    | Generation 4 (Excel) Series                         |      |   |
| G 5    | Generation 5 Series                                 |      |   |

Figure 5-2 Legend - Electrical Schematic Diagrams

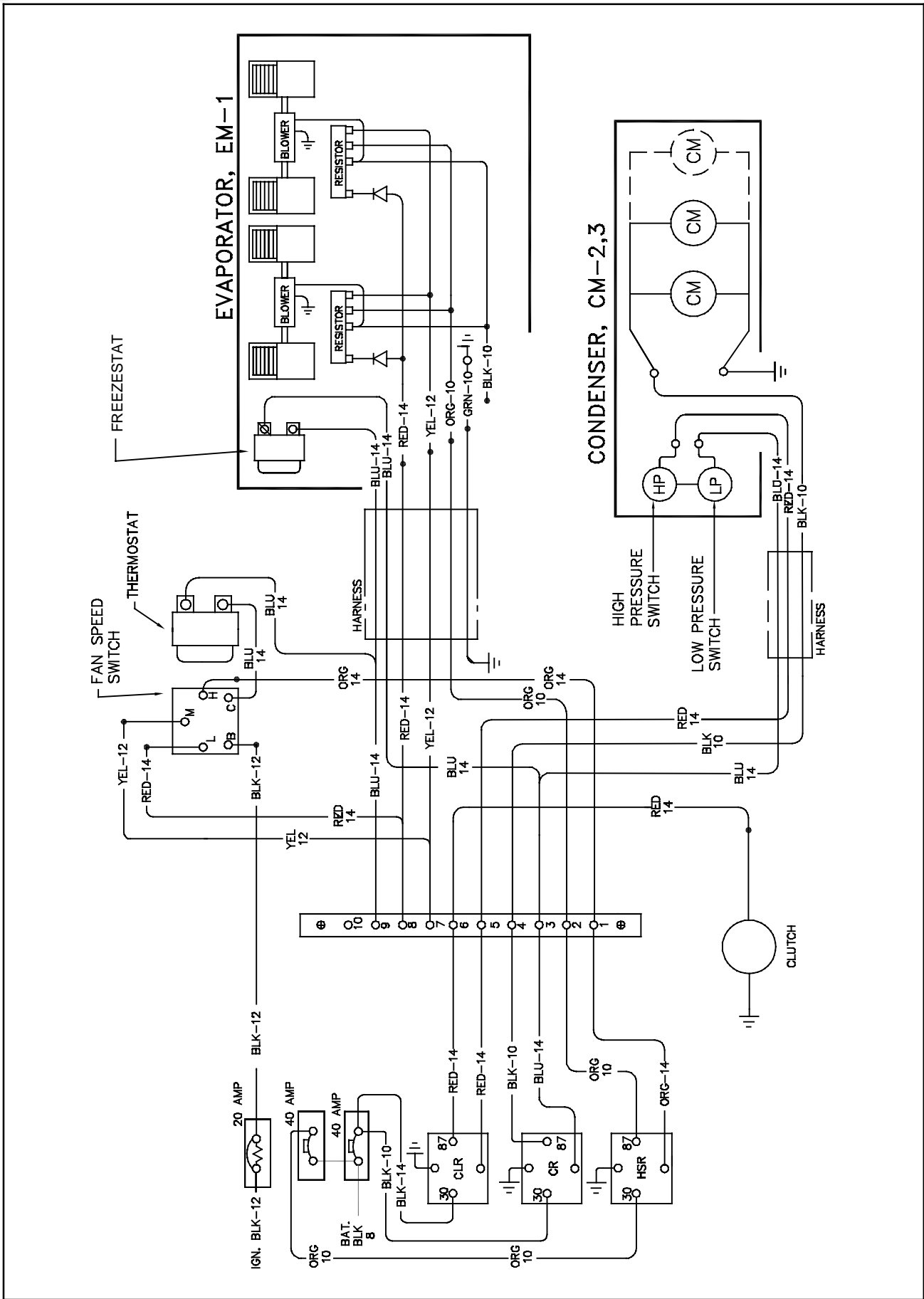
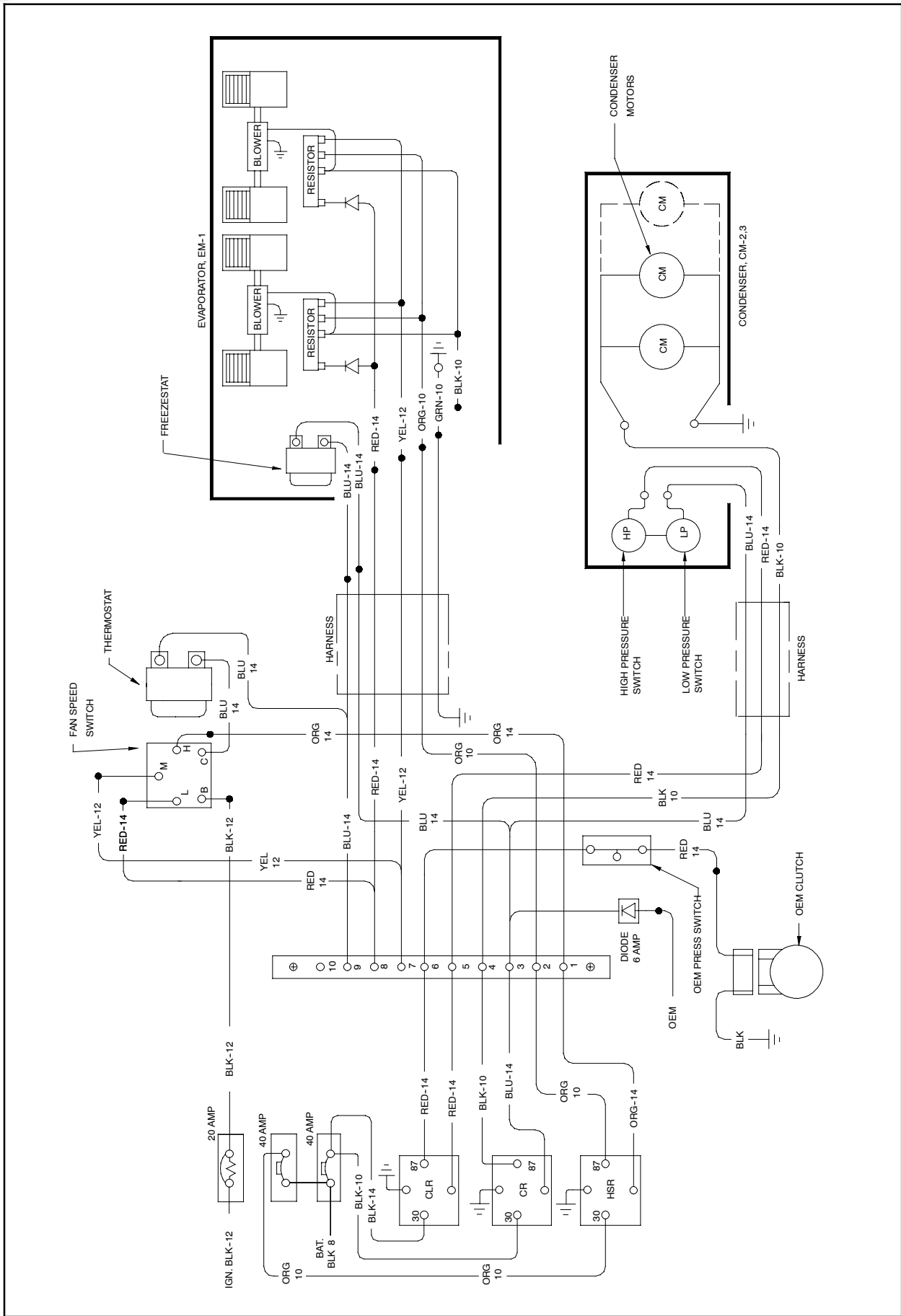

Figure 5-3 GEN 4 System Schematic - EM-1 With CM-2/3





**Figure 5-4 GEN 4 System Schematic - EM-1 With CM-2/3 - Tie-In**

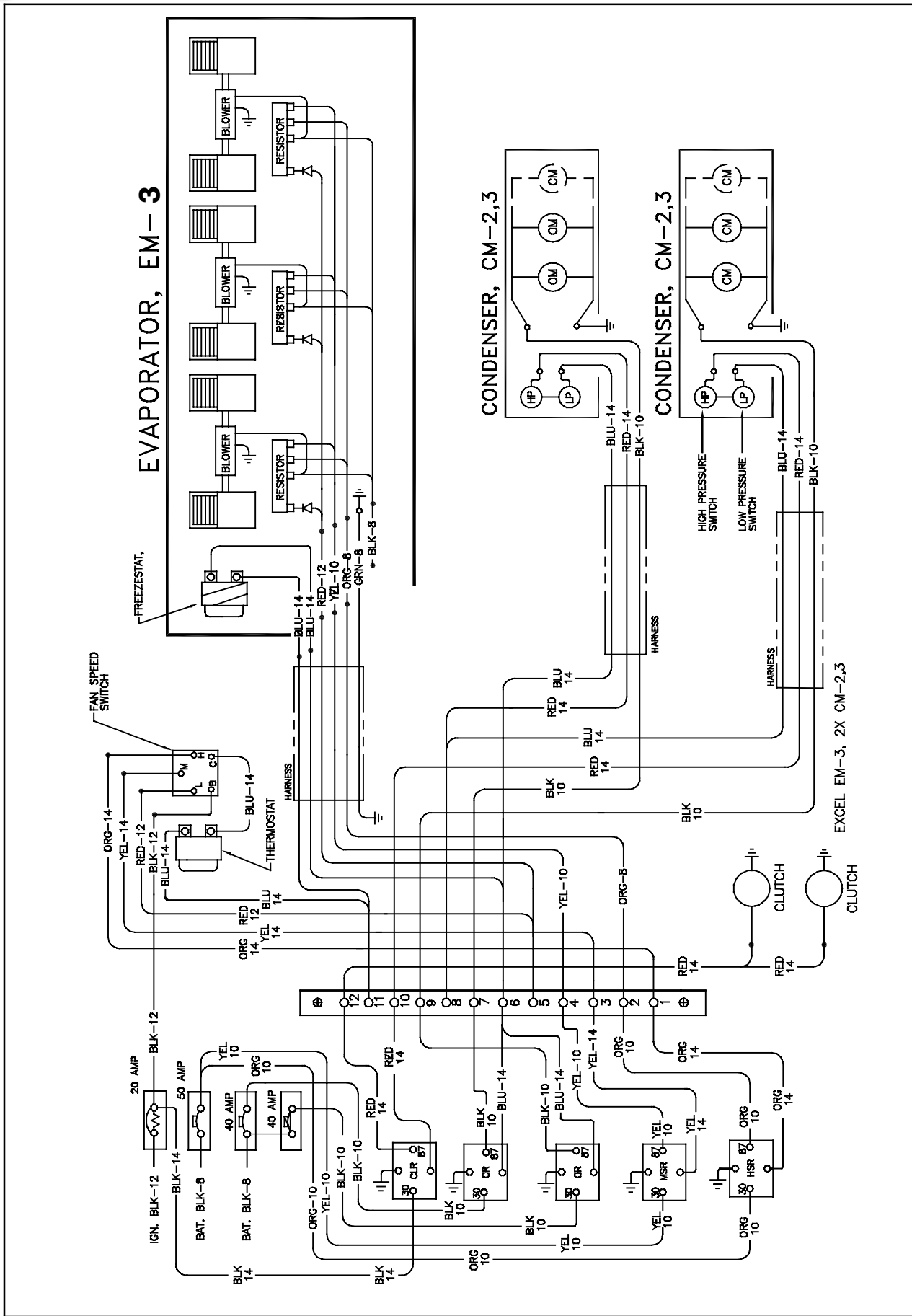

Figure 5-5 GEN 4 System Schematic - EM-3 With (2) CM-3 Condensers & (2) Compressors

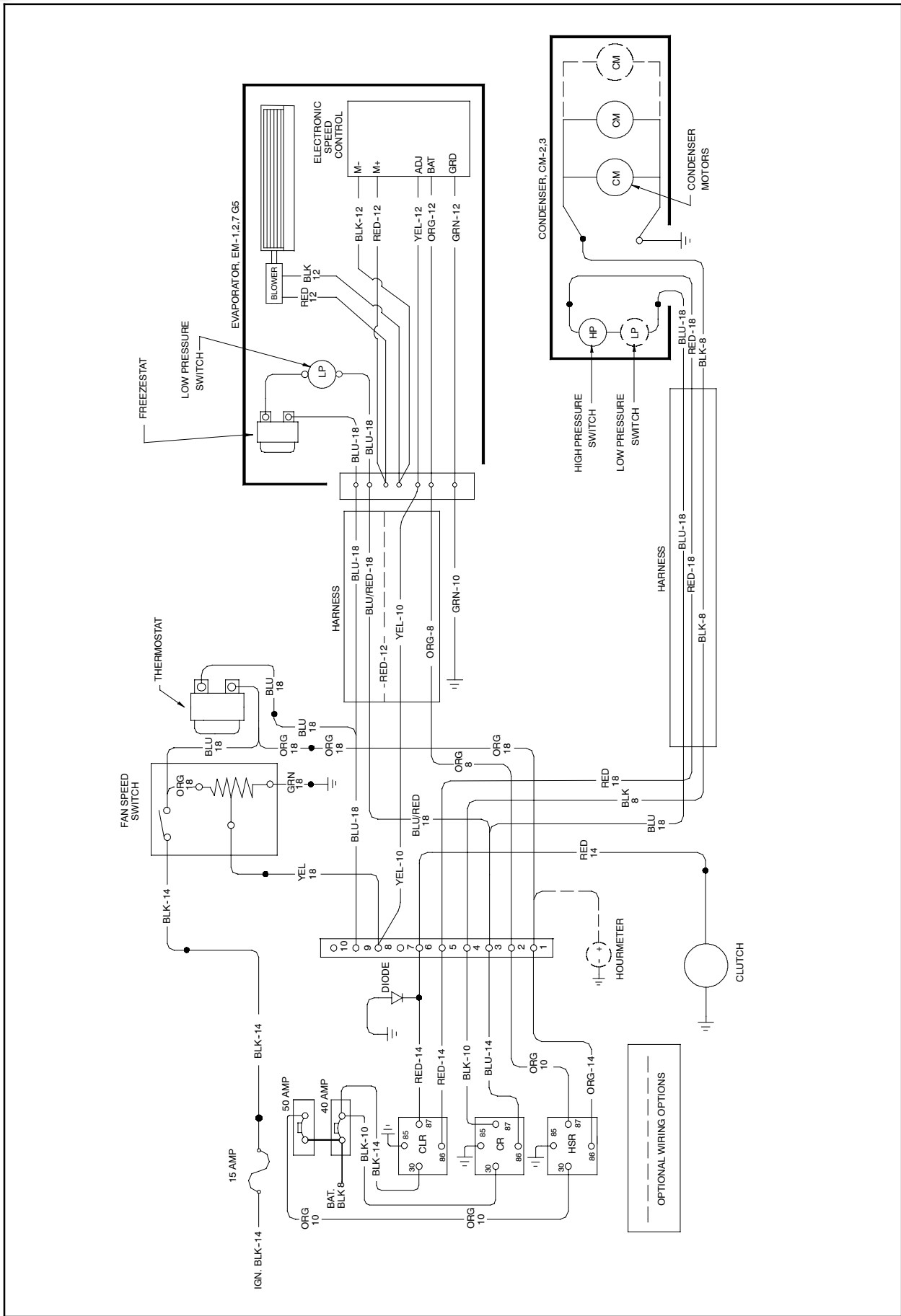

Figure 5-6 GEN 5 Evaporator (With Variable Speed Control) Schematic

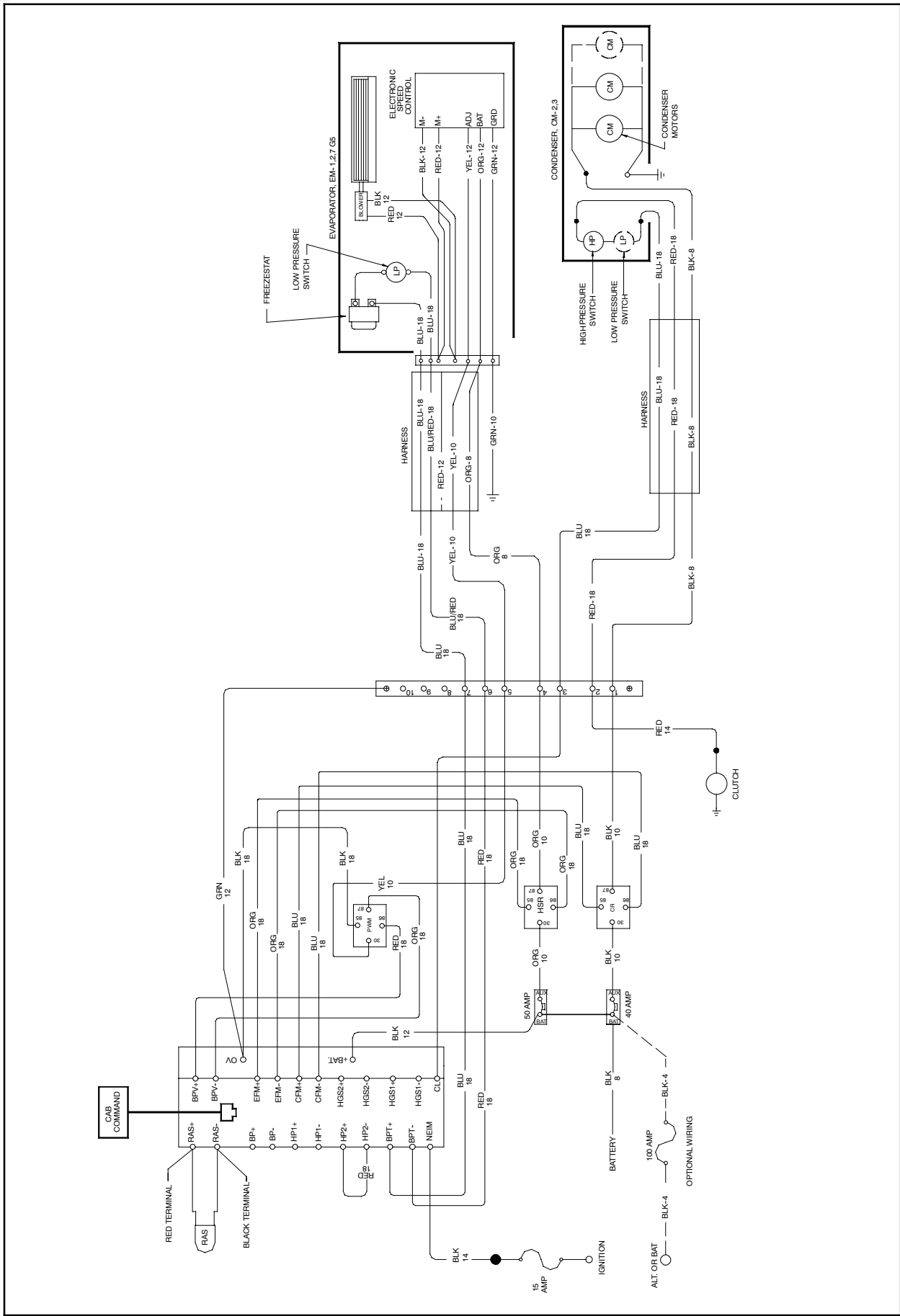

Figure 5-7 GEN 5 System Schematic With Total Control

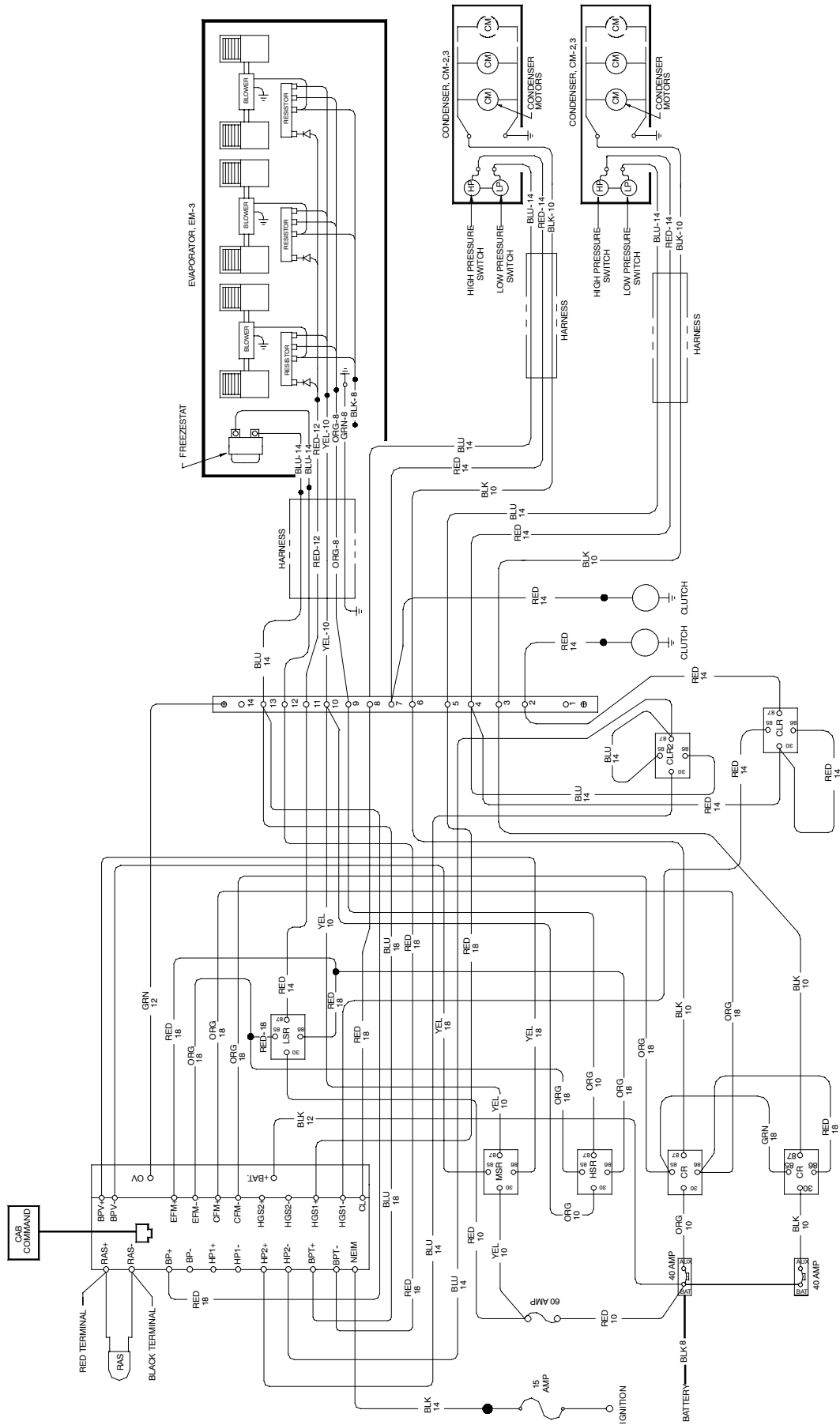

Figure 5-8 GEN 4 EM-3 With (2) CM-3 With Total Control - System Schematic

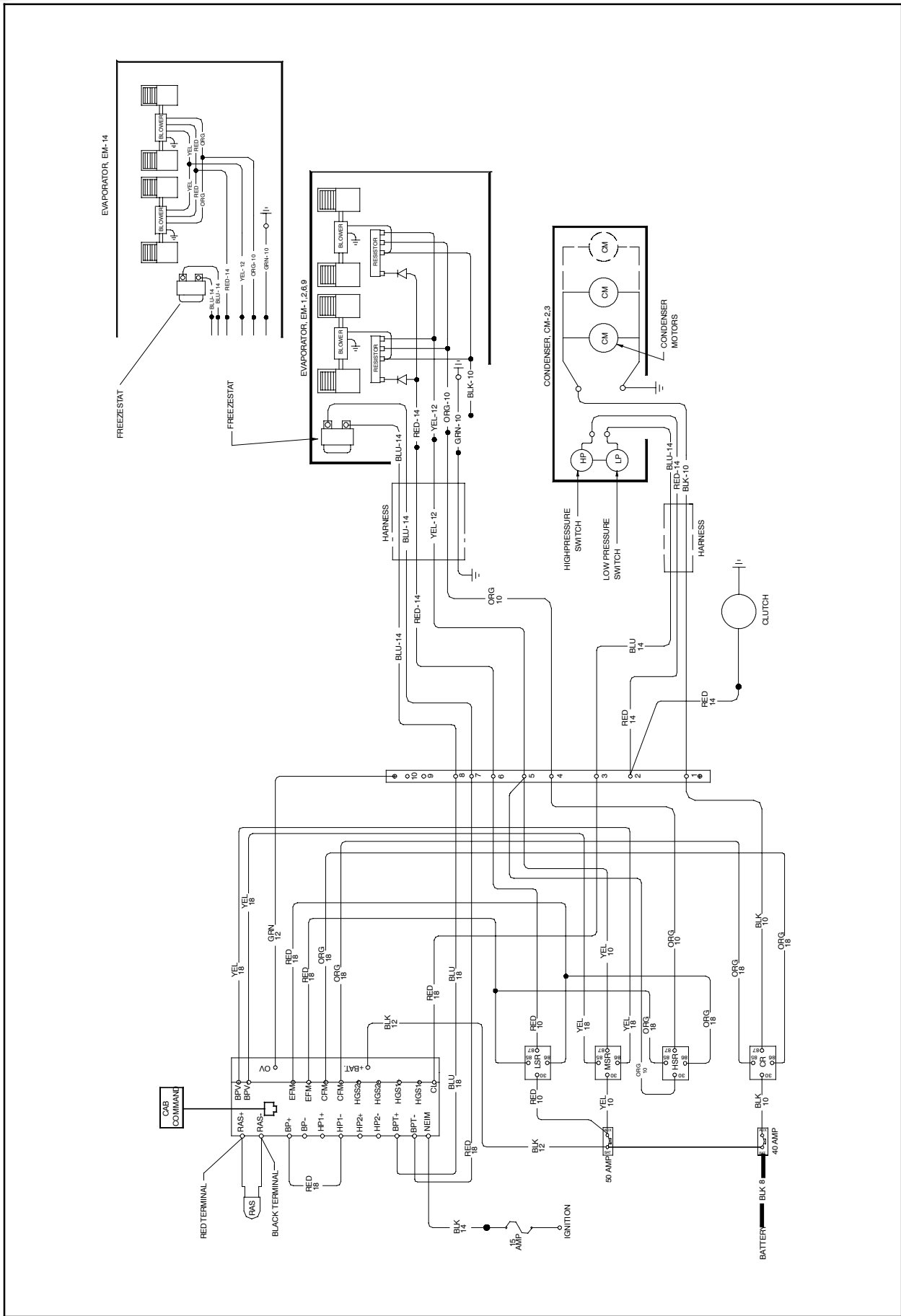
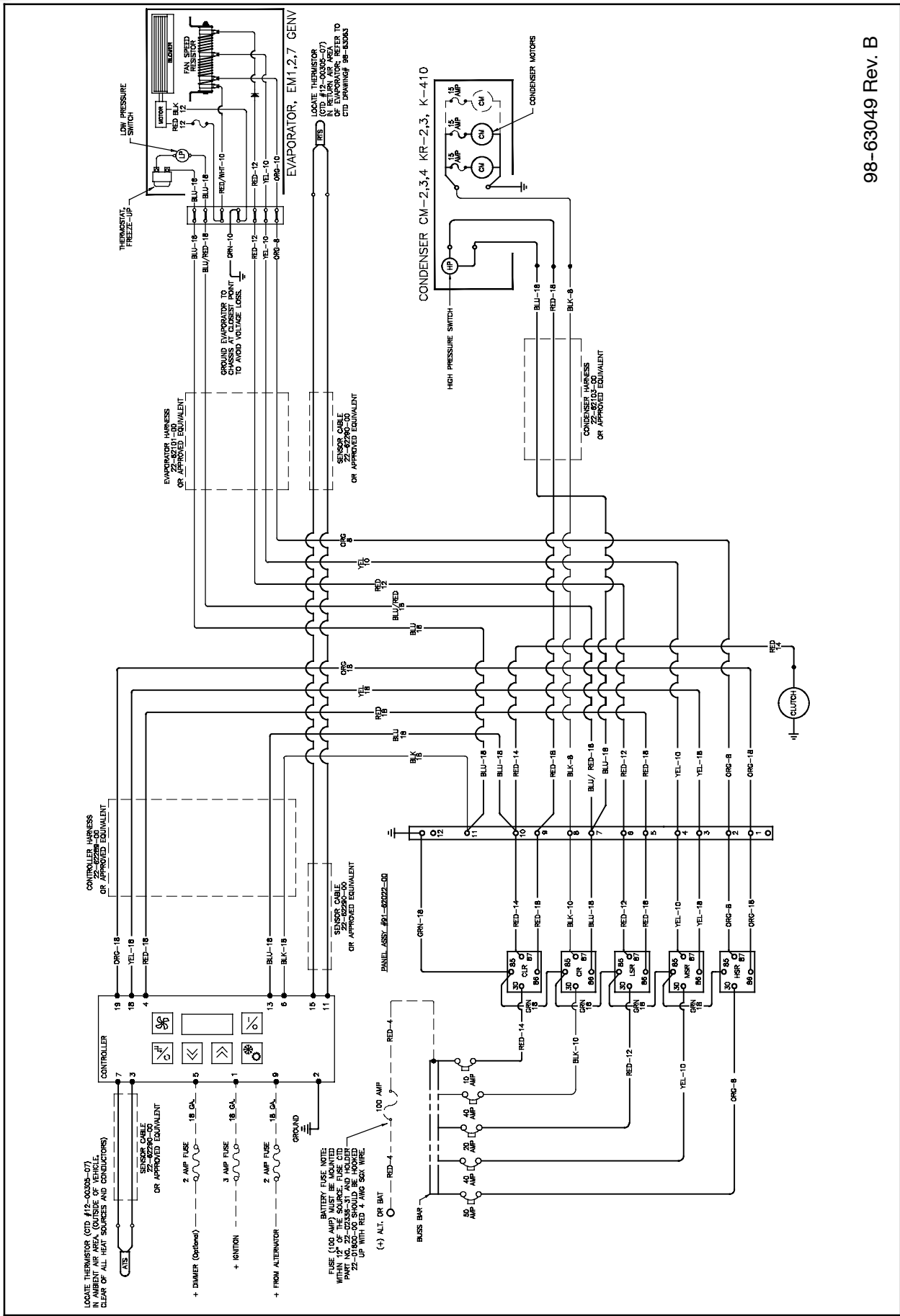

Figure 5-9 GEN 4 Series With Total Control





98-63049 Rev. B

Figure 5-10 Gen V with EnviromATE Controller (Single Zone)

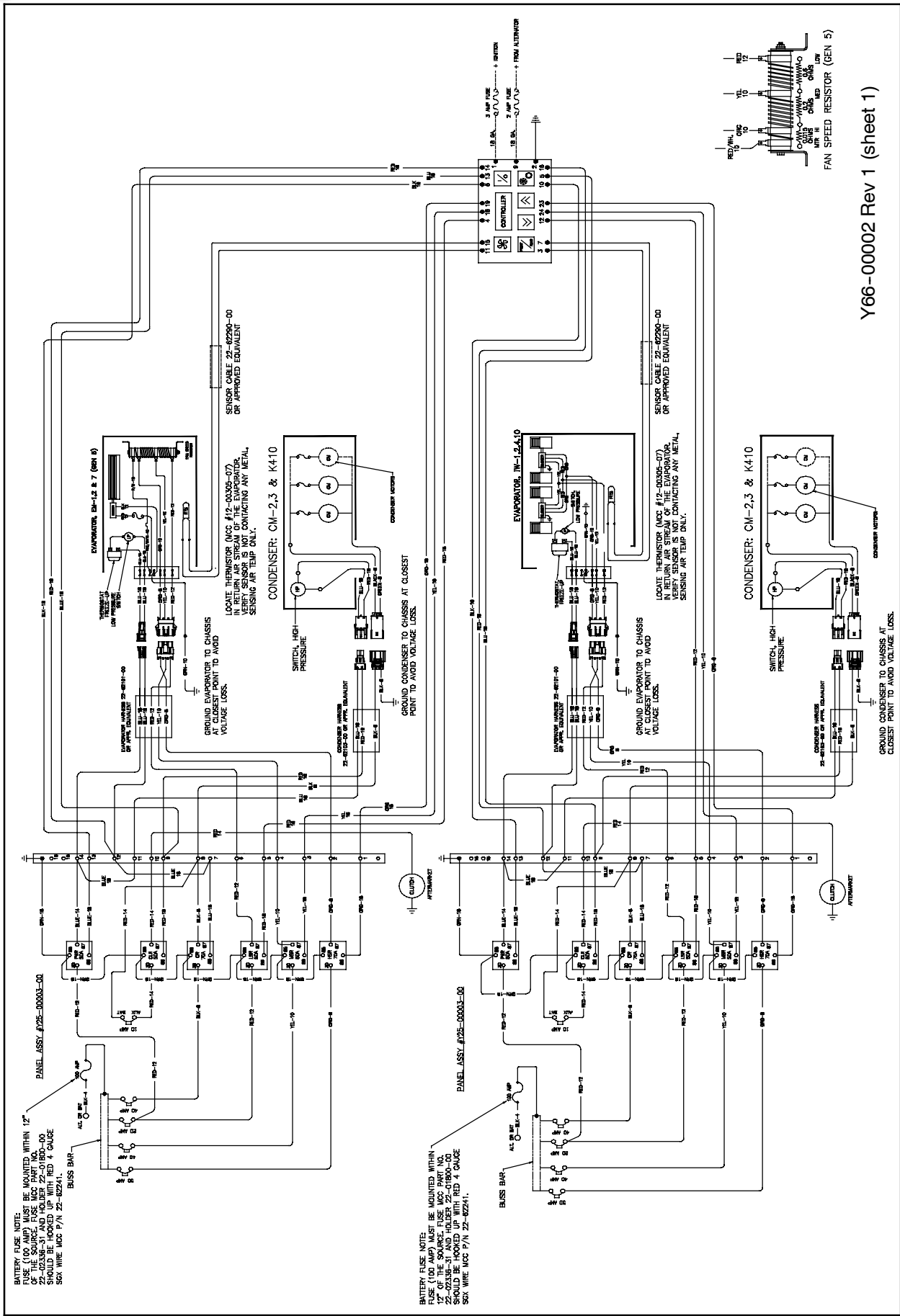

Y66-00002 Rev 1 (sheet 1)

Figure 5-11 Gen V with EnviroMATE Controller (Dual Zone, 2 Evaporators, 2 condensers, 2 Compressors)

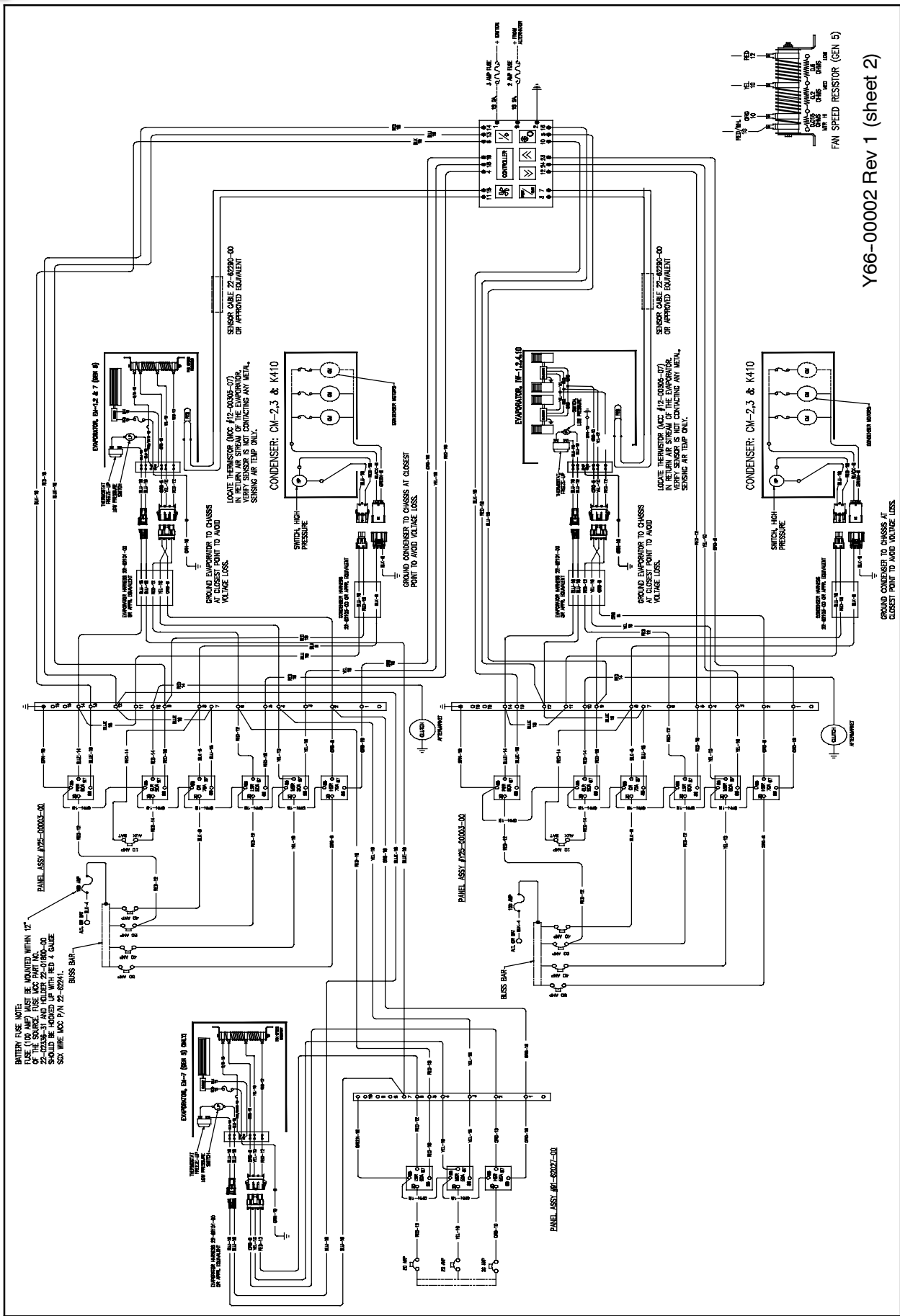

Y66-00002 Rev 1 (sheet 2)

Figure 5-12 Gen V with EnviroMATE Controller (Dual Zone, 3 Evaporators, 2 Compressors)



## **A**

Adding Refrigerant, 4-6  
AIR CONDITIONING, 1-1

## **C**

CHECKING AND REPLACING HIGH PRESSURE SWITCH, 4-16  
COMPONENT SPECIFICATIONS, 1-6  
COMPRESSORS, 4-7  
CONDENSER FAN ASSEMBLY, 4-16  
COOLING CYCLE, 1-7

## **D**

DESCRIPTION , 1-1  
DRIVE BELT INSTALLATION, 4-12  
Driver's Control Panel, 2-1

## **E**

Electrical Control Panel, 2-1  
ELECTRICAL SCHEMATIC DIAGRAMS, 5-1  
EnviroMATE Controller (Dual Zone), 2-11  
EnviroMATE Controller (Single Zone), 2-8  
EVACUATION , 4-5  
EVAPORATOR BLOWER/MOTOR, 4-15  
Evaporator Tie-In, 4-9

## **F**

Fan Speed Switch , 2-1  
FILTER-DRIER, 4-17  
FLORIDA CONTROL, 2-2

## **G**

GEN 4 - WITH TOTAL CONTROL, 2-5  
GEN 4 - WITH TOTAL CONTROL, UNIT OPERATING INSTRUCTIONS, 2-5

## **H**

Heat Option, 2-7  
HEATING CYCLE , 1-10  
High Pressure Switch, 4-16

## **I**

IN-LINE FUSE , 2-2  
INSTALLING MANIFOLD GAUGES, 4-2  
INSUFFICIENT COOLING, 3-1

## **L**

LEAK CHECKING, 4-5  
Low Pressure Switch, 4-16

## **M**

MAINTENANCE PROCEDURES, 4-2  
MANUAL CONTROLS, 2-1  
MODEL TAG, 1-1  
MOISTURE INDICATOR (SYSTEM), 4-17

## **O**

OPERATING INSTRUCTIONS , 2-1  
OPERATION , 2-1

## **P**

PID Data Tag, 1-1  
PRE-TRIP INSPECTION, 2-5  
PREVENTATIVE MAINTENANCE SCHEDULE, 4-1



## **R**

REFRIGERANT CHARGE, 4-6  
REFRIGERANT RECOVERY, 4-5  
REPLACING BLOCK VALVE, 4-16  
RESISTORS, 4-15  
RETURN AIR FILTER, 4-14

## **S**

SEQUENCE OF OPERATION, 2-5  
SERVICE, 4-1  
SYSTEM COMPONENTS , 1-5  
SYSTEM DESIGNATIONS, 1-5  
SYSTEM REQUIREMENTS LABEL, 1-5

## **T**

Thermostat Control, 2-1  
Three Position Switch Operation, 2-5  
TORQUE SPECIFICATIONS - BOLTS, 4-11  
TORQUE SPECIFICATIONS - FITTINGS, 4-11  
TOTAL CONTROL, 2-3  
Total Control - Gen 4 Operation, 2-6  
Total Control - Gen 5 Operation, 2-6  
Total Control Operation, 2-3  
TROUBLESHOOTING, 3-1

## **V**

Variable Speed Control Operation, 2-6

# Every driver deserves the best possible vehicle climate with MCC products

MCC provides exceptional performance in mobile climate comfort.



[www.mcc-hvac.com](http://www.mcc-hvac.com)

Member of MCC Group • Certified ISO 9001 and ISO 14001.  
Specifications subject to change without notice. MCC is a registered trademark.