

Bill of Materials Listing

TransArctic Canada Inc.

7/26/2013
Page 1 of 1

Product Number	Description	Date	Weight	Uof M	Yield
Line Component Prod#	Description	Bin Unit	Qty		
KMC62079	Mt Kit, ISB, 6.7L, BBCV, 2 TM-16,'07-'13	05/05/10	45.96		0
5 PAC23150	Pack, Carton, 23" x 15" x 10", 51 ECT	each	1		
10 BEL61918	Belt, 6gr, 1918mm (75.5") (5060755)	each	1		
20 BMC60037	Bkt, Shroud, Cover, 12 Ga. (.1046")	each	1		
30 BMC67003	Bkt, Brace, Diag, D/S, Sup,6.7,LISB,Conv	each	1		
40 BMC67077	Bkt, Main, Weldmt, 6.7L, Slide Tens,'13	each	1		
50 BMC67048	Bkt, Spacer, Weldm't, 6.7L, ISB, '10	each	1		
60 BMC67049	Bkt, Brace, Diag, RR, Sup,6.7L, ISB,'13	each	1		
70 PUL80076	Pulley, Idler, Backside, P8, 76d (89101)	each	1		
72 SPC19010	Spacer, Col, Drl, 19mm x 28.58o x 10.32i	each	1		
74 SLV17010	Sleeve, Pulley, 16.9o x 22.23mm x 10.32i	each	1		
80 TEN80002	Tenr, HD Spring, BackSide, CCW (89200A)	each	1		
90 KBC62679	Bag Kit, Fasteners, KMC62679/2079	each	1		

NOTES:

1) For the '07 & 10 emissions bus engine:

Use part# BMC67049 brace with the slotted hole at the top & bolted to the slotted hole in the base weld'mt. (part# BMC67077.)

2) For the "13 emmissions version flip the brace up-side-down with the slotted hole bolted to the (BMC67048) Spacer Weldm't/Engine block and the top round hole to the matching round hole in the Main Weldm't. (BMC67077.)

/Val_FEB-19-13

Add the "KMC626/2079 install notes for a 2007 emissons BBCV bus.doc" file to the MPW.

Bill of Materials Listing

TransArctic Canada Inc.

7/26/2013
Page 1 of 1

Product Number	Description	Date	Weight	Uof M	Yield
Line Component Prod#	Description	Bin Unit	Qty		
KBC62679	Bag Kit, Fasteners, KMC62679/2079		05/06/10	2.06	0
10	BTC08035	Bolt, Hex, 8 x 1.25 x 35mm, 10.9, Plt,FT	each	1	
20	BTC08065	Bolt, Hex, 8 x 1.25 x 65mm, 10.9, Plt	each	1	
25	BTC10075	Bolt, Hex, 10 x 1.5 x 75mm, 10.9, Plt	each	1	
30	BTC08100	Bolt, Hex, 8 x 1.25 x 100mm, 10.9, Plt	each	7	
40	BTC10025	Bolt, Hex, 10 x 1.5 x 25mm, 10.9, Plt	each	1	
50	BTC10030	Bolt, Hex, 10 x 1.5 x 30mm, 10.9, Plt	each	8	
60	BTC10035	Bolt, Hex, 10 x 1.5 x 35mm, 10.9, Plt,FT	each	1	
80	BTC10060	Bolt, Hex, 10 x 1.5 x 60mm, 10.9, Plt	each	2	
90	BTC10080	Bolt, Hex, 10 x 1.5 x 80mm, 10.9, Plt,FT	each	1	
110	NTA10000	Nut, Hex, 10 x 1.5, 8.8, Plt	each	2	
120	WFA08000	Washer, Flat, 8mm, 8.8, Plt	each	7	
130	WFA10000	Washer, Flat, 10mm, 8.8, Plt	each	4	
135	WFA10002	Washer, Flat, 10mm, Hvy, 8.8, Plt	each	1	
140	WLA08000	Washer, Lock, 8mm, 8.8, Plt	each	9	
150	WLA10000	Washer, Lock, 10mm, 8.8, Plt	each	14	

**ATTENTION:
IT IS CRITICAL TO READ ALL TENSIONING
ADJUSTMENT NOTES ON THIS DRAWING.**

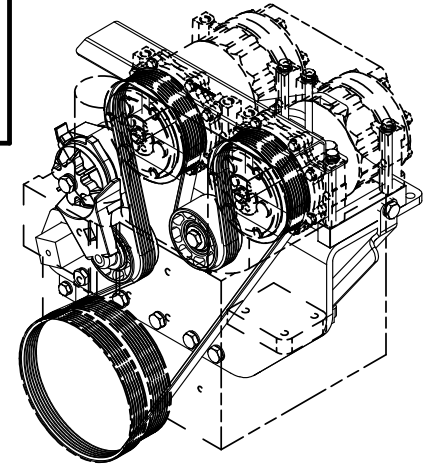

ISOMETRIC VIEW

NOTE:
INSTALL THE 6 GR. BELT ON THE
MIDDLE 6 GROOVES OF THE 8 GR.
COMPRESSOR PULLEY.

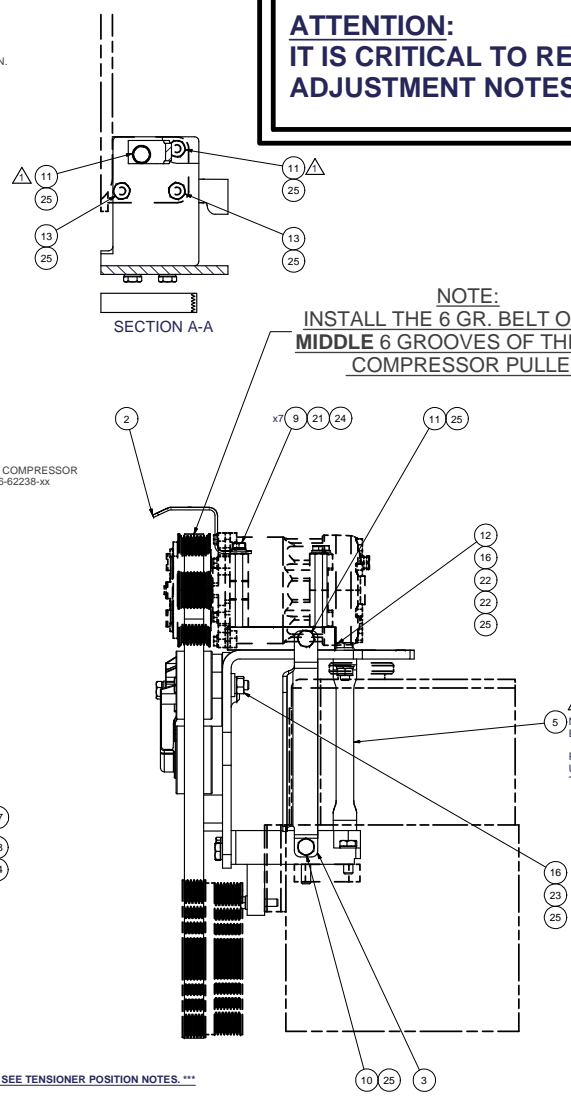
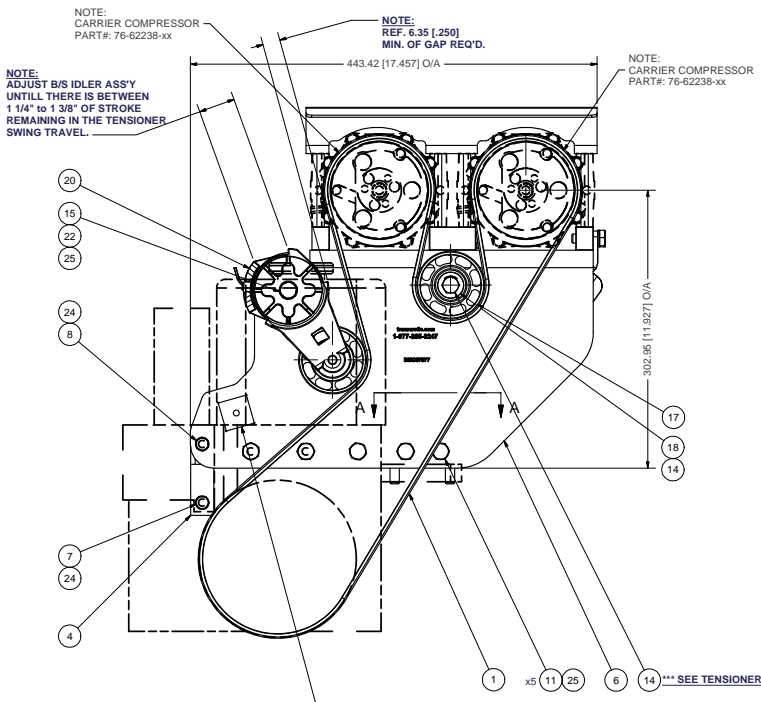
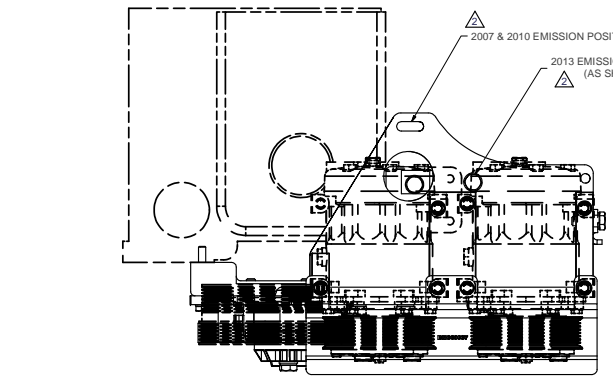

NOTE: ITEM# 5 SHOWN IN THE 2013 EMISSION POSITION.
FOR THE 2007 & 2010 EMISSION POSITION FLIP ITM#5 UPSIDE DOWN AND USE THE REAR SLOTTED HOLE ON THE TOP FACE OF ITM# 6.

- NOTES:
- 1) USE SERVICABLE THREADLOCKER ON ALL FASTENERS TO ENGINE COMPONENTS AND TORQUE ALL BOLTS TO S.A.E. SPECIFICATIONS.
 - 2) SEE "TRANSARGTIC A/C COMPRESSOR MOUNT INSTALLATION DISCLAIMER".
 - 3) THERE ARE MULTIPLE FAN CLUTCH ARRANGEMENT OPTIONS AVAILABLE FOR THIS ENGINE. INSURE THAT THERE IS THE CORRECT GAP AND CORRECT TENSIONER STROKE REMAINING UPON FINAL OPERATING INSTALLATION.

ITEM	QTY	U/M	PART NUMBER	DESCRIPTION
25	14	EACH	WLA10000	WASHER, LOCK, 10mm, 8.8, PLT
24	9	EACH	WLA08000	WASHER, LOCK, 8mm, 8.8, PLT
23	1	EACH	WFA10002	WASHER, FLAT, 10mm, HVY, 8.8, PLT
22	4	EACH	WFA10000	WASHER, FLAT, 10mm, 8.8, PLT
21	7	EACH	WFA08000	WASHER, FLAT, 8mm, 8.8, PLT
20	1	EACH	TEN80002	TENR, HD SPRING, BACKSIDE, CCW
19	1	EACH	SPC19010	SPACER, COL, DRL, 19.05mm x25.4x x10.571
18	1	EACH	SLV17010	SLEEVE, PULLEY, 16.9x x 22.23mm x 10.321
17	1	EACH	PUL80076	PULLEY, IDLER, BACKSIDE, P8, 76D, 39W
16	2	EACH	NTA10000	NUT, HEX, 10 x 1.5, 8.8, PLT
15	1	EACH	BTC10080	BOLT, HEX, 10 x 1.5 x 80mm, 10.9, PLT
14	1	EACH	BTC10075	BOLT, HEX, 10 x 1.5 x 75mm, 10.9, PLT
13	2	EACH	BTC10060	BOLT, HEX, 10 x 1.5 x 60mm, 10.9, PLT
12	1	EACH	BTC10035	BOLT, HEX, 10 x 1.5 x 35mm, 10.9, PLT
11	8	EACH	BTC10030	BOLT, HEX, 10 x 1.5 x 30mm, 10.9, PLT
10	1	EACH	BTC10025	BOLT, HEX, 10 x 1.5 x 25mm, 10.9, PLT
9	7	EACH	BTC08100	BOLT, HEX, 8 x 1.25 x 100mm, 10.9, PLT
8	1	EACH	BTC08065	BOLT, HEX, 8 x 1.25 x 65mm, 10.9, PLT
7	1	EACH	BTC08035	BOLT, HEX, 8 x 1.25 x 35mm, 10.9, PLT
6	1	EACH	BMC67077	BKT, MAIN, WELDMT 6.7L, SLIDE TENS, '13
5	1	EACH	BMC67049	BKT, BRACE, DIAG, RR, SUP, 6.7L, ISB, '13
4	1	EACH	BMC67048	BKT, SPACER, WELDMT, 6.7L, ISB, '10
3	1	EACH	BMC67003	BKT, BRACE, DIAG, D/S, SUP, 6.7L, ISB, CON
2	1	EACH	BMC60037	BKT, SHROUD, COVER, 12 GA, (10447)
1	1	EACH	BEL1918	BELT, egr, 1918mm (75.5") (5000755)

BILL OF MATERIALS

BROWN vjakowlew 06/16/11
 CHECKED: 11/08/12 VAL/J
 RELEASSED TO PRODUCTION: 06/16/2011 VAL/J
 GA

REV: ECN DESCRIPTION: DATE: BY: APPROVED

James Stewart 6/16/2011
 MFG James Stewart 06/16/11
 Dale Mason 06/16/11

THIS DRAWING CONTAINS PROPRIETARY CONFIDENTIAL INFORMATION OWNED BY TRANSARGTIC CANADA INC. THE DOCUMENT AND THE INFORMATION IN IT ARE NOT TO BE USED, DISCLOSED OR REPRODUCED WITHOUT EXPRESS WRITTEN PERMISSION OF THE COMPANY.

UNSPECIFIED TOLERANCES:
 DIM DECIMAL PLACE (X) .00 (FRACTIONAL) .000
 DIM INCH (X) .0005 (FRACTIONAL) 1/1000

THIRD ANGLE PROJECTION

DRAWING UNIT OF MEASURE: MM (INCH)

SCALE: 3:8

DWG NO: KMC62079

REV: 2

SHEET 1 OF 1



MT KIT, ISB, 6.7L, BBCV, 2 TM-16, '07-'13

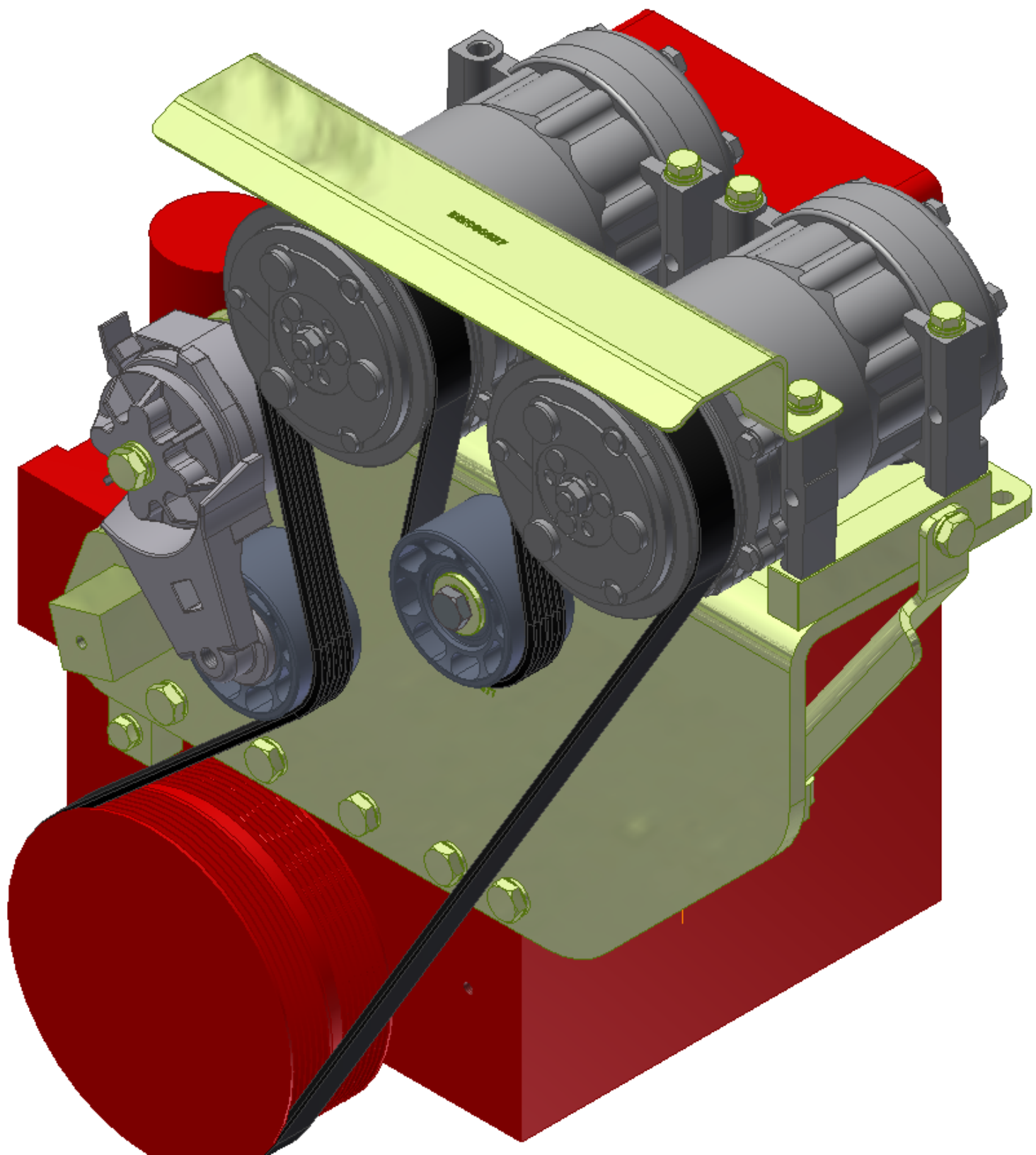

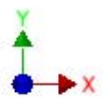
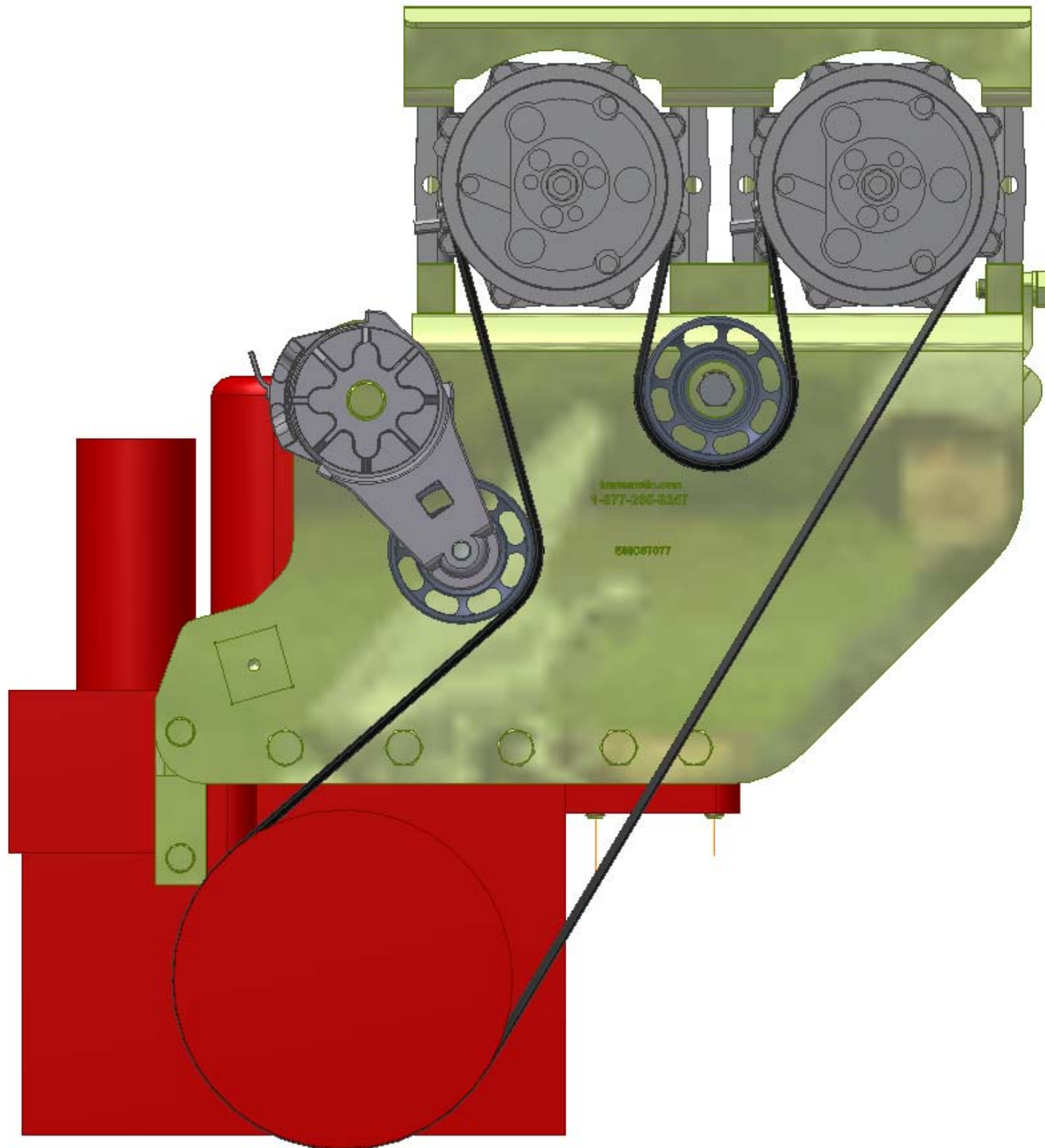

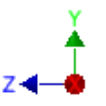
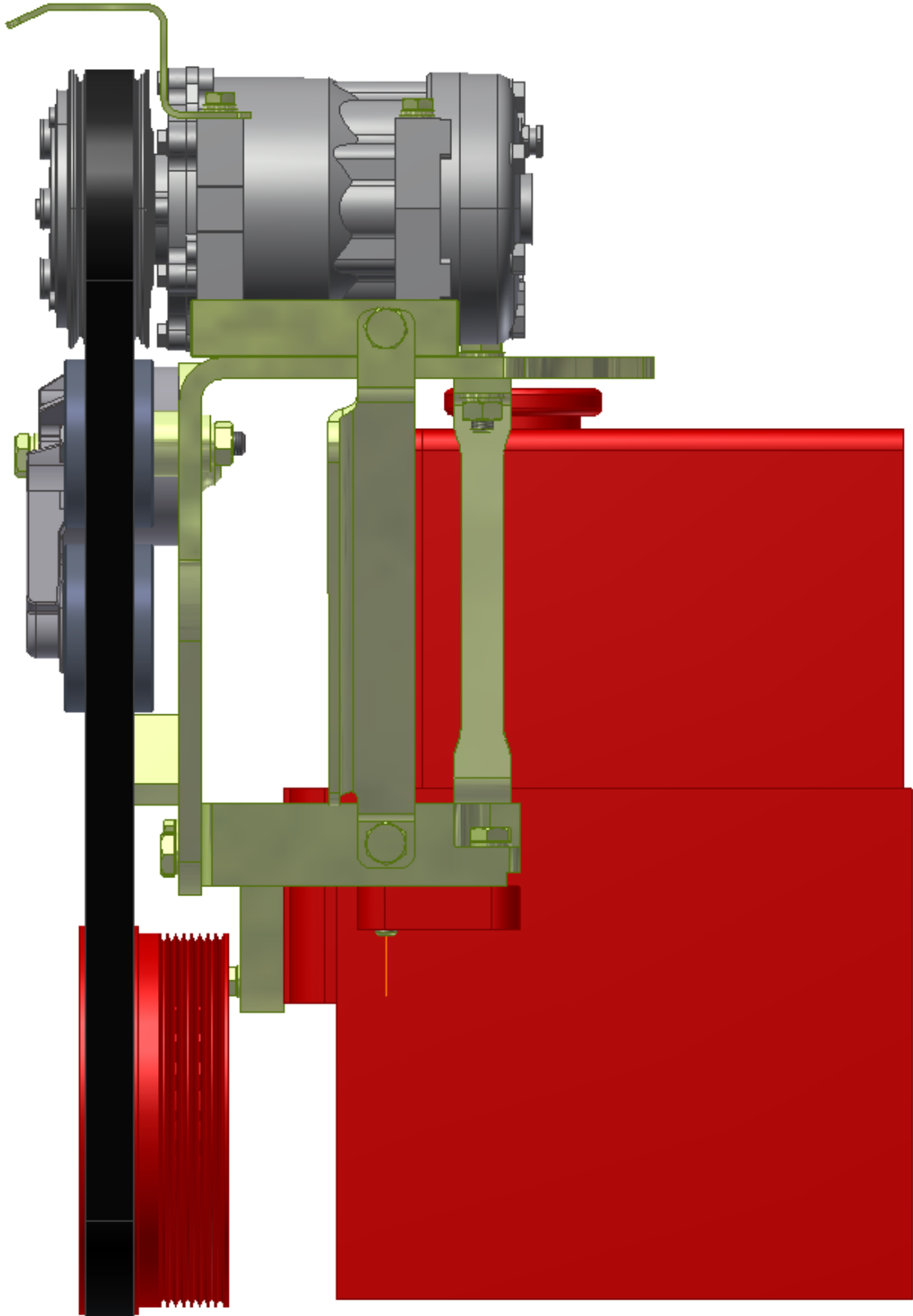

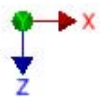
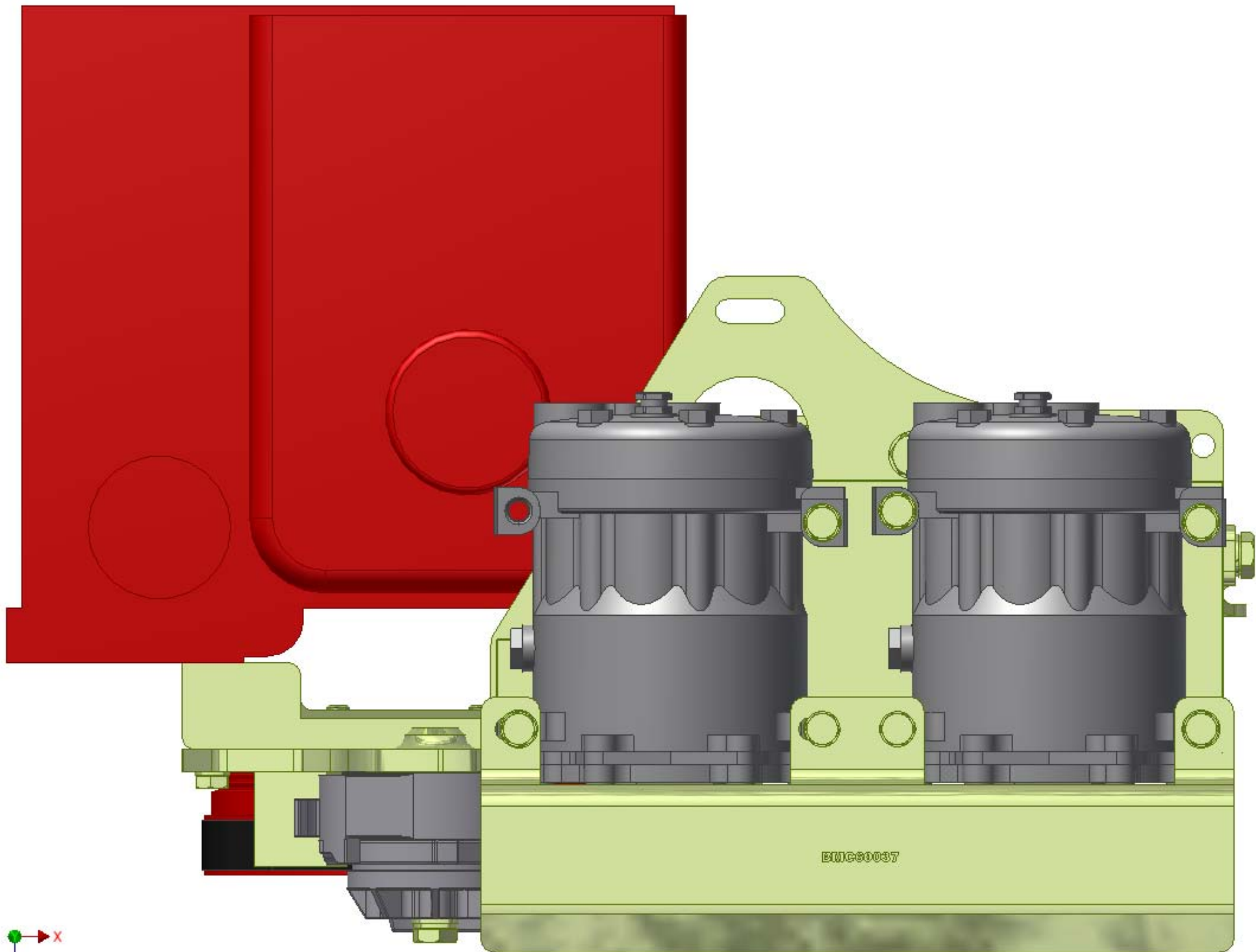

REROUTE EXISTING FAN WIRE &
SECURE TO SUIT NEW INSTALLATION.

USE EXISTING FAN
STRAP & HARDWARE.

NOTE: THIS IS JUST ONE TYPE
OF FAN CLUTCH ARRGM'T
AVAILABLE FOR THIS ENGINE.
ADJUST YOUR INSTALLATION
TO SUIT THE CORRECT
"TENSIONER STROKE
REMAINING" DIMENSION & MIN.
GAP REQUIREMENTS.

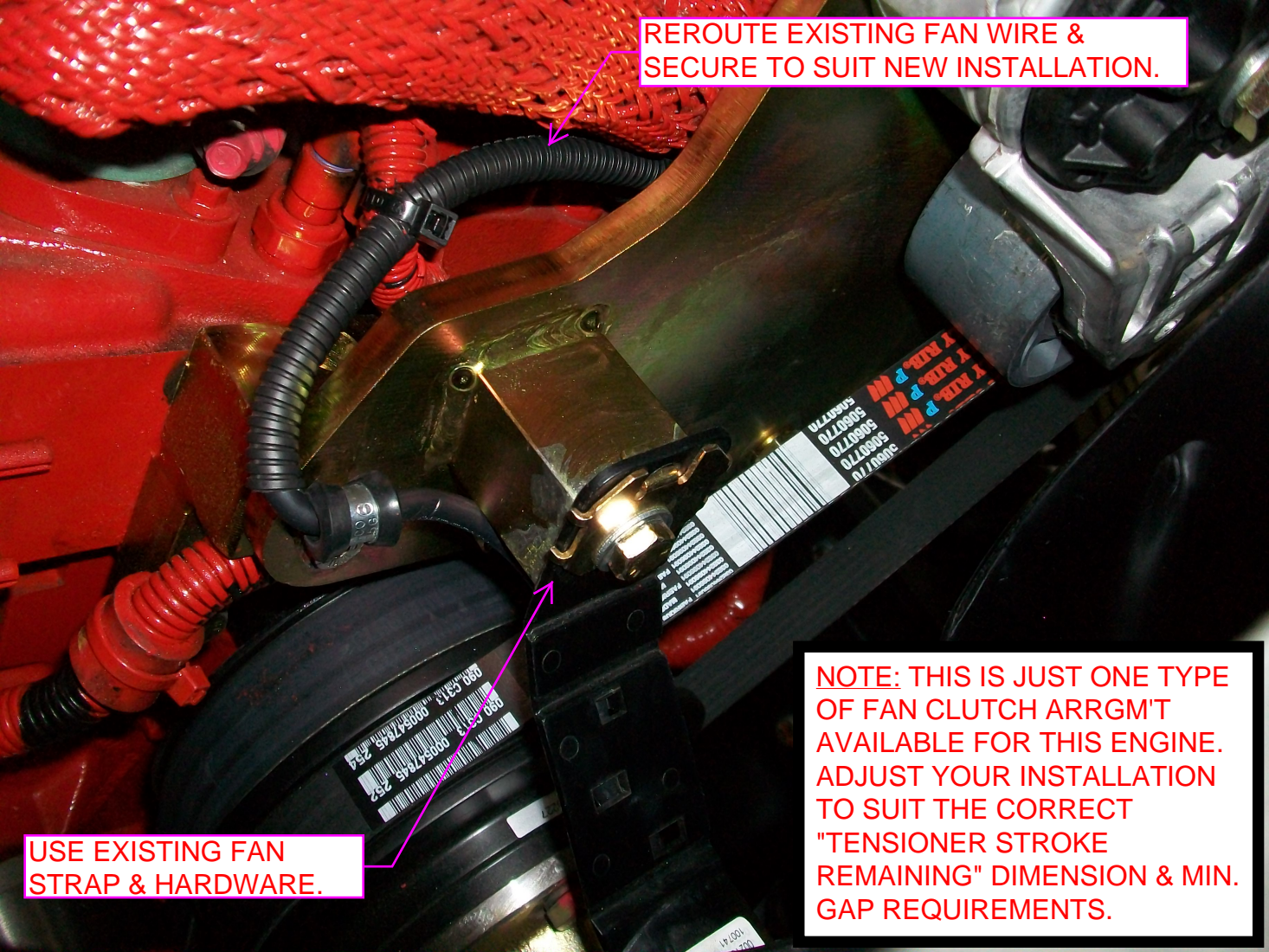

TransArctic A/C Compressor Mount Installation Disclaimer

All compressor mounts should be installed by qualified and trained personnel using proper tools and equipment in safe working conditions following industry standard guidelines for motor vehicle service and repair.

The installer of any compressor mount purchased from TransArctic must undertake all responsibility of issues arising from that compressor bracket being installed on any vehicle. As well as insure that a **proper and sufficient ground** is established between the compressors' clutches and the vehicle's engine. Mount functionality, operation and durability can all be compromised by an incompetent installation.

Due to the many different situations, parameters and application criteria, which are beyond the compressor mount manufacturer's control, TransArctic does not warrant design, durability, or operational functionality of any compressor mount improperly installed by another party.

With no implied guarantees it is the mount installer's strict responsibility to determine safety and functionality, of the compressor mount, at the time of installation.

Please contact TransArctic with any issue arising from installation so we may better improve the product. If you have any reservations about the compressor mount integrity contact TransArctic immediately at 1-877-COLD-AIR.

Mark OEM tensioner location

Install Kit

Check for Interferences

Check to ensure that the proper OEM tensioner orientation is maintained

Run engine with A/C system engaged for at least 10 minutes to run in belt

Check OEM tensioner orientation and adjust as required

Responsabilidad limitada de TransArctic en la instalación del soporte del compresor

Todos los soportes de los compresores deben ser instalados por personas calificadas y entrenadas, usando para ello los equipos y herramientas necesarios para esta labor en buenas condiciones y según las normas y guías para el servicio y/o reparación de motores de vehículos.

El instalador de los soportes comprados en TransArctic asume toda la responsabilidad de cualquier problema que surja en el soporte del compresor al vehículo; de igual manera es responsable que el cable a tierra sea conectado entre el embrague del compresor y el motor del vehículo.

Se advierte que el buen funcionamiento y la durabilidad del soporte pueden ser comprometidos por defectos en su instalación.

Debido a las diversas situaciones que se puedan presentar fuera del control del fabricante, TransArctic no garantiza el diseño, la durabilidad o el correcto funcionamiento de cualquier equipo inapropiadamente instalado por terceros.

Esta sobreentendido que el Instalador del montaje del compresor es estrictamente responsable de la seguridad y funcionamiento del equipo en el momento de la instalación.

Si tuviera algún problema o duda acerca de la instalación del soporte del compresor pongase en contacto inmediatamente con TransArctic al teléfono 1-877-COLD-AIR de modo que podamos mejorar nuestro producto.

Note la ubicación del medidor de tensión OEM

Instale el equipo

Controlar si hay interferencias.

Asegurese que el medidor de tensión mantenga la orientación justa.

Encienda el motor por lo menos 10 minutos con el sistema A/C enganchado para que la correa corra

Controle la orientación justa del medidor de tensión y ajuste a las condiciones requeridas del fabricante

OCT-27-2011

Dear Customer,

The enclosed mount kit (KMC62079) was developed for the 6.7 L Cummins 2010 emissions BBCV bus with its varying fan pulley configurations. (Hopefully it will cover all of the different arrangements while utilizing a single common belt length.)

We also believe that it will fit the 2007 emissions 6.7 L Cummins engine in the BBCV's. Please note that the "adjustable backside idler pulley" will probably be at the top of its adjustable slot, to make the tensioner's "adjustable dimensions" work out in this install.

Please install this kit utilizing the enclosed mount kit paperwork and contact me at our toll free number 1-877-265-3247, to confirm all the information in these documents with the actual and correct installation.

If you have any questions or concerns with this mount kit install please contact me at your earliest convenience at the above toll free number.

Thank you,
&
Kindest Regards,

Val Jakowlew