

# Bill of Materials Listing

TransArctic Canada Inc.

8/5/2008  
Page 1 of 1

Product Number	Description	Date	Weight	Uof M	Yield
Line    Component Prod#	Description	Bin                      Unit	Qty		
<b>KMC61374</b>	<b>Mt Kit, ISB 6.7L, TH C2, TM-21, MAX, '07</b>		<b>7/31/2007</b>	<b>14.62</b>	<b>0</b>
10 BEL11176	Belt, A gr, 1176mm (46.3") (17463)		each	1	
20 BMC59033	Bkt, Main, Weldmt, ISB, A3FE		each	1	
30 BMC59035	Bkt, Cradle, BTM, 87mm, ISB, A3FE		each	1	
40 BMC59037	Bkt, Spacer, Bar, ISB, A3FE		each	1	
50 PUL10094	Pulley, Idler, SA,94d x 18w,Blk (IP-103)		each	1	
60 PUL67002	Pulley, Fan, ADD-ON, Cummins, ISB,6.7,SA		each	1	
70 SCD12717	Spacer, Col, Drl, 12.7mm x 25.4o x17i		each	1	
80 SLV17010	Sleeve, Pulley, 16.9o x 22.23mm x 10.32i		each	1	
90 TEN00002	Tenr, Spring, Un-Direct, 90d, 3/8 x 4.5"/3.5"		each	1	
100 KBC61374	Bag Kit, Fasteners, KMC61374/1074		each	1	

# Bill of Materials Listing

TransArctic Canada Inc.

8/5/2008  
Page 1 of 1

Product Number	Description	Date	Weight	Uof M	Yield
Line    Component Prod#	Description	Bin                      Unit	Qty		
<b>KBC61374</b>	<b>Bag Kit, Fasteners, KMC61374/1074</b>		<b>7/26/2006</b>	<b>0.98</b>	<b>0</b>
10 BTC10050	Bolt, Hex, 10 x 1.5 x 50mm, 10.9, Plt	each	2		
20 BTC10045	Bolt, Hex, 10 x 1.5 x 45mm, 10.9, Plt	each	1		
25 BTC10040	Bolt, Hex, 10 x 1.5 x 40mm, 10.9, Plt	each	1		
30 BTC08100	Bolt, Hex, 8 x 1.25 x 100mm, 10.9, Plt	each	4		
40 BTC08040	Bolt, Hex, 8 x 1.25 x 40mm, 10.9, Plt	each	1		
50 BTC08035	Bolt, Hex, 8 x 1.25 x 35mm, 10.9, Plt	each	1		
60 BTC08015	Bolt, Hex, 8 x 1.25 x 15mm, 10.9, Plt	each	1		
70 CSF06250	Capscrew, FH, 3/8-16 x 2.5", Alloy, Plt	each	1		
80 NTA10000	Nut, Hex, 10 x 1.5, 8.8, Plt	each	1		
90 WFA08000	Washer, Flat, 8mm, 8.8, Plt	each	7		
100 WFA10000	Washer, Flat, 10mm, 8.8, Plt	each	4		
110 WLA08000	Washer, Lock, 8mm, 8.8, Plt	each	7		
120 WLA10000	Washer, Lock, 10mm, 8.8, Plt	each	4		



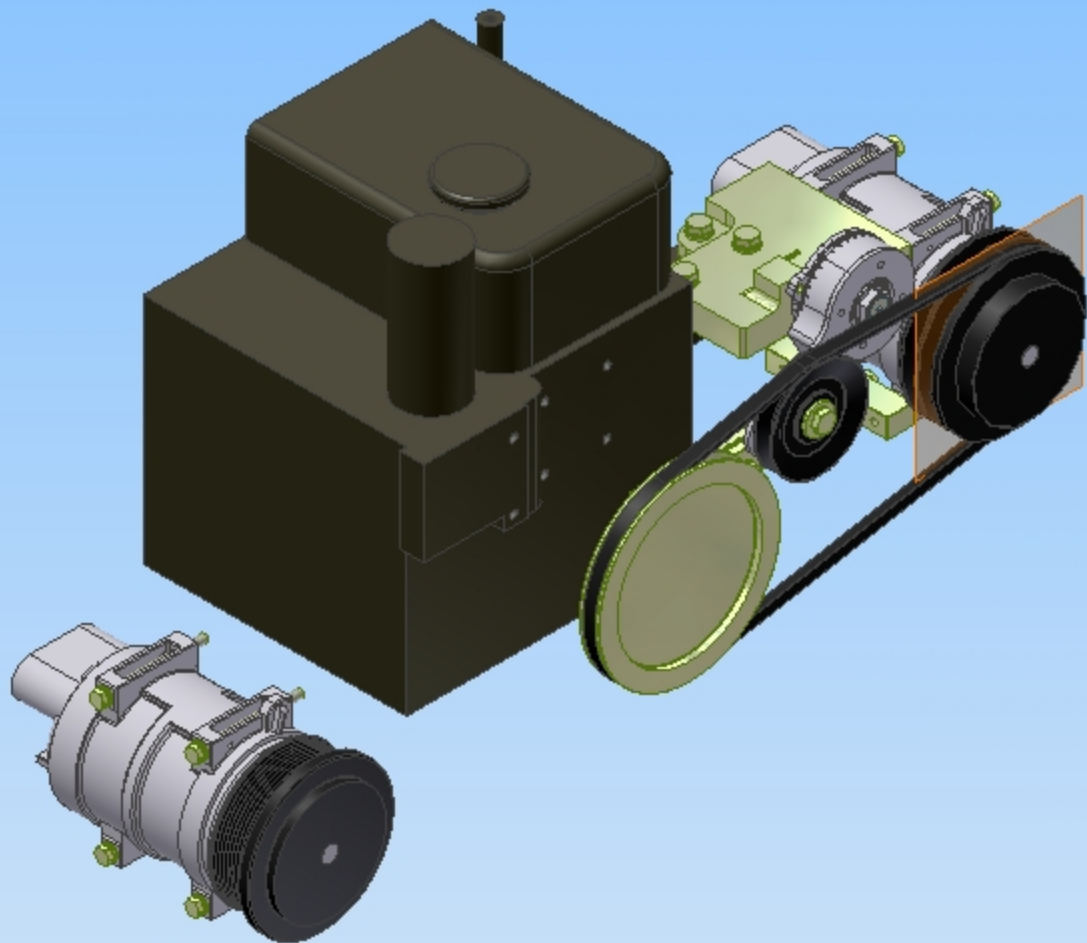

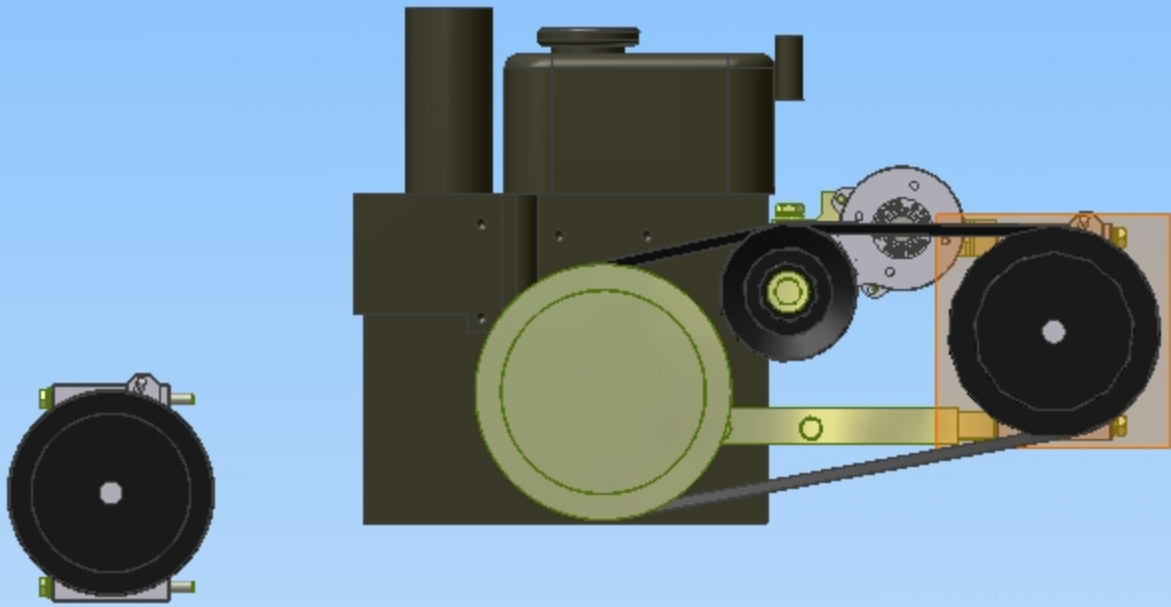

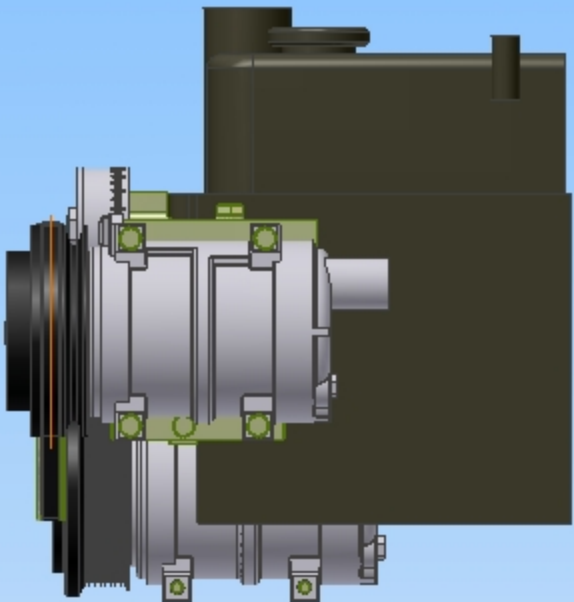

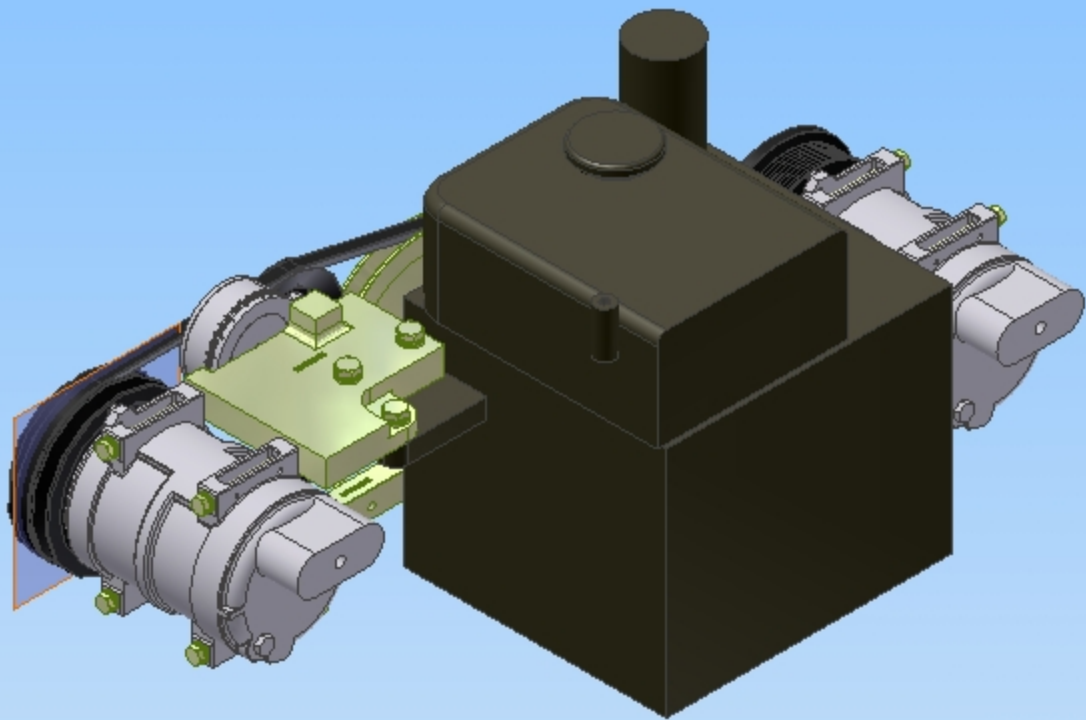

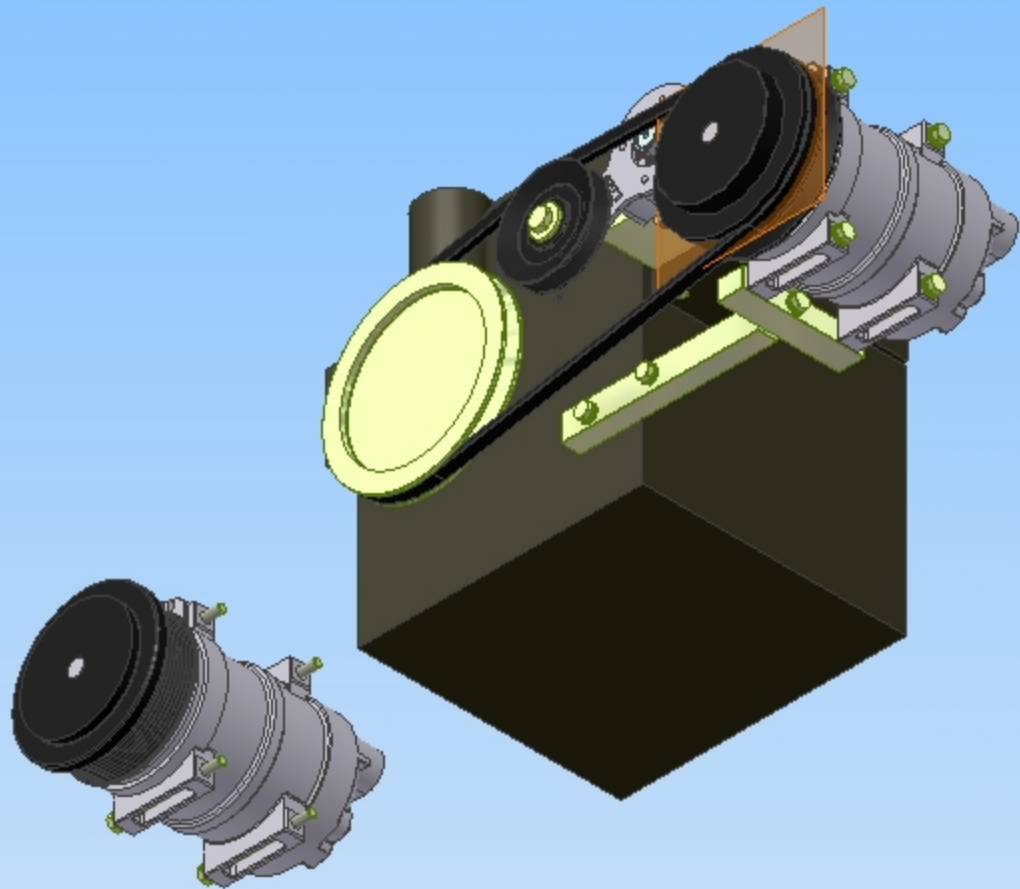



## **TransArctic A/C Compressor Mount Installation Disclaimer**

All compressor mounts should be installed by qualified and trained personnel using proper tools and equipment in safe working conditions following industry standard guidelines for motor vehicle service and repair.

The installer of any compressor mount purchased from TransArctic must undertake all responsibility of issues arising from that compressor bracket being installed on any vehicle. As well as insure that a **proper and sufficient ground** is established between the compressors' clutches and the vehicle's engine. Mount functionality, operation and durability can all be compromised by an incompetent installation.

Due to the many different situations, parameters and application criteria, which are beyond the compressor mount manufacturer's control, TransArctic does not warrant design, durability, or operational functionality of any compressor mount improperly installed by another party.

**With no implied guarantees it is the mount installer's strict responsibility to determine safety and functionality, of the compressor mount, at the time of installation.**

Please contact TransArctic with any issue arising from installation so we may better improve the product. If you have any reservations about the compressor mount integrity contact TransArctic immediately at 1-877-COLD-AIR.