



SERVICE MANUAL

Valeo TM-55 & TM-65 Compressors



valeo added 

Copyright © 2010 Valeo Compressors. All rights reserved.

Valeo
Automotive technology, naturally

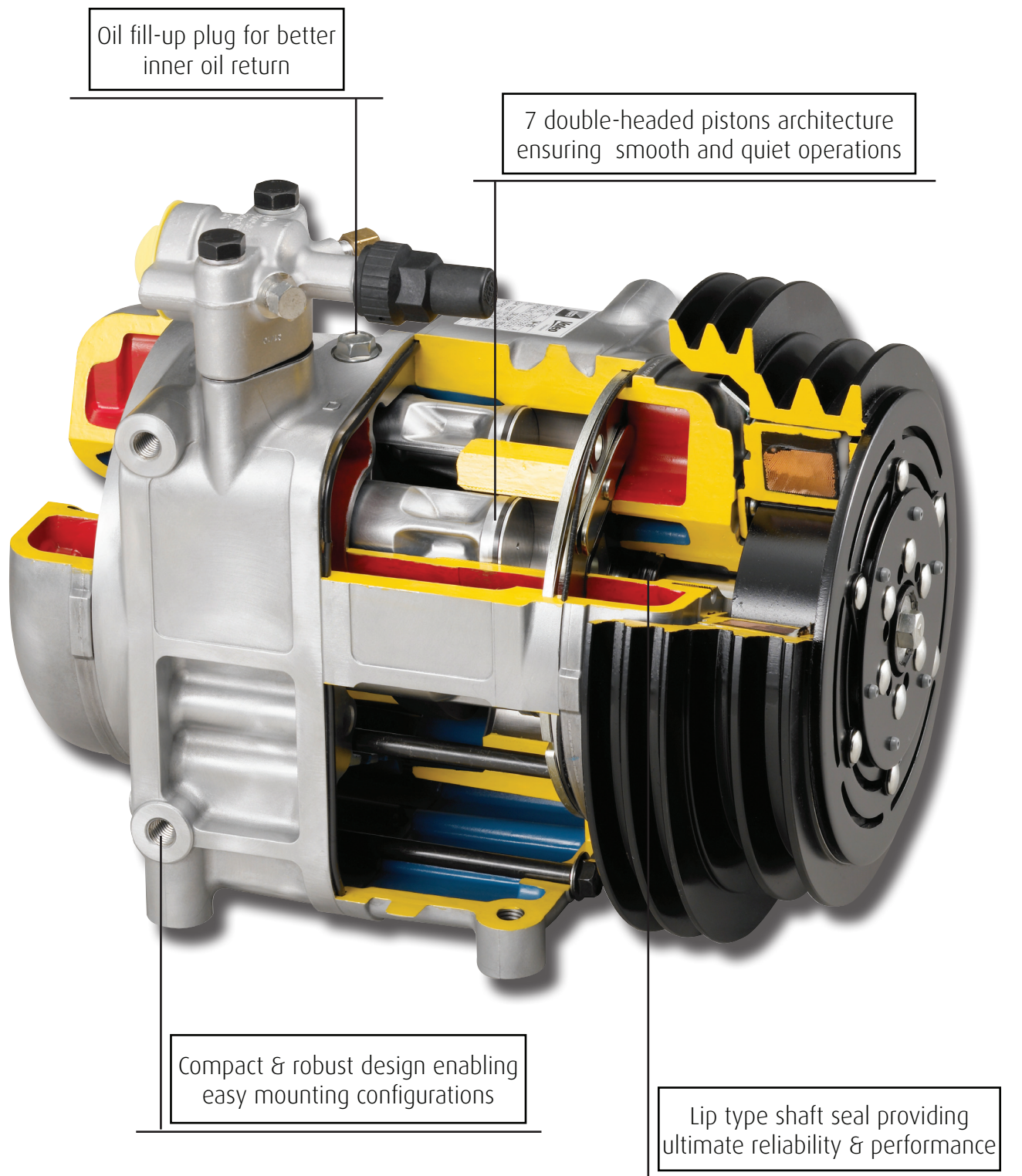

Oil fill-up plug for better inner oil return

7 double-headed pistons architecture ensuring smooth and quiet operations

Compact & robust design enabling easy mounting configurations

Lip type shaft seal providing ultimate reliability & performance

Light & Compact, Ultimate Reliability, Highest Performance

valeo added ■■■■■■

Foreword

This service manual has been elaborated to help service personnel to provide efficient and correct service and maintenance on the Valeo **TM-55** and **TM-65** compressors for bus air conditioning.

This manual includes the operation specifications, procedures for disassembly, reassembly, and inspection of the compressor.

The contents of the manual, including illustrations, drawings and specifications were the latest available at the time of printing.

The right is reserved to make changes in specifications and procedures at any time without notice.

VALEO THERMAL SYSTEMS JAPAN CO., LTD.

WARNINGS

The following definitions and warning signs are used in this service manual. These are extremely important to ensure safe operation. Important points are described to prevent body injuries and property damage. They must be fully understood before starting air conditioning maintenance.

WARNING!! Maintenance must be properly done to avoid serious injury risks.

CAUTION!! Improper maintenance can result in injury or proper damage.

MEANING OF MARKS

The following marks are used in this service manual to facilitate correct air conditioner maintenance.

Advice Procedures necessary to ensure the best air conditioner maintenance.

Note Information to optimize the air conditioning maintenance.

Contents

1- Product description.....	3
2- Operation precautions	15
3- Handling instructions.....	16
Maintenance precautions	16
Work area.....	16
Refrigerant handling	16
Compressor handling.....	17
Compressor removal.....	17
Oil return operation	18
Oil handling.....	18
Oil contamination	19
Oil check.....	19
Replacement of components	20
Running-in operation.....	21
Compressor running-in.....	21
Magnetic clutch running-in.....	21
Leak test.....	22
Storing a repaired compressor	22
4- Trouble shooting	23
Compressor trouble shooting.....	23
Compressor trouble shooting arborescence.....	23
A/C cycle diagnosis by gauge pressure	26
5- Tightening torques.....	28
6- Service procedures - Magnetic clutch.....	29
7- Service procedures - Shaft seal assembly.....	33
8- Service procedures - Cylinder heads.....	36
9- Service tools.....	40
10- Service parts	46

1- Product description - Compressor

Compressor

MODEL	TM-55	TM-65
TECHNOLOGY	Heavy Duty Swash Plate	
DISPLACEMENT	550 cc / 33.56 in ³ per rev.	635cc / 38.75 in ³ per rev.
NUMBER OF CYLINDERS	14 (7 double-headed pistons)	
REVOLUTION RANGE	600-4000 rpm	
DIRECTION OF ROTATION	Clockwise viewed from clutch	
BORE	38.5 mm (1.52 in)	
STROKE	33.7 mm (1.30 in)	38.9 mm (1.53 in)
SHAFT SEAL	Lip seal type	
LUBRICATION SYSTEM	Lubrication by gear pump	
REFRIGERANT	HFC-134a	
OIL (QUANTITY)	ZXL 100PG PAG OIL (1500 cc/0.40 gal) or POE option	
WEIGHT	18.1kg / 39.9lb (w/o Clutch)	
DIMENSIONS Length - Width - Height	341 - 194 - 294 (mm) 13.4 - 7.64 - 9.33 (in)	
MOUNTING	Direct (side or base)	

Valeo **TM-55 & TM-65** Application limits

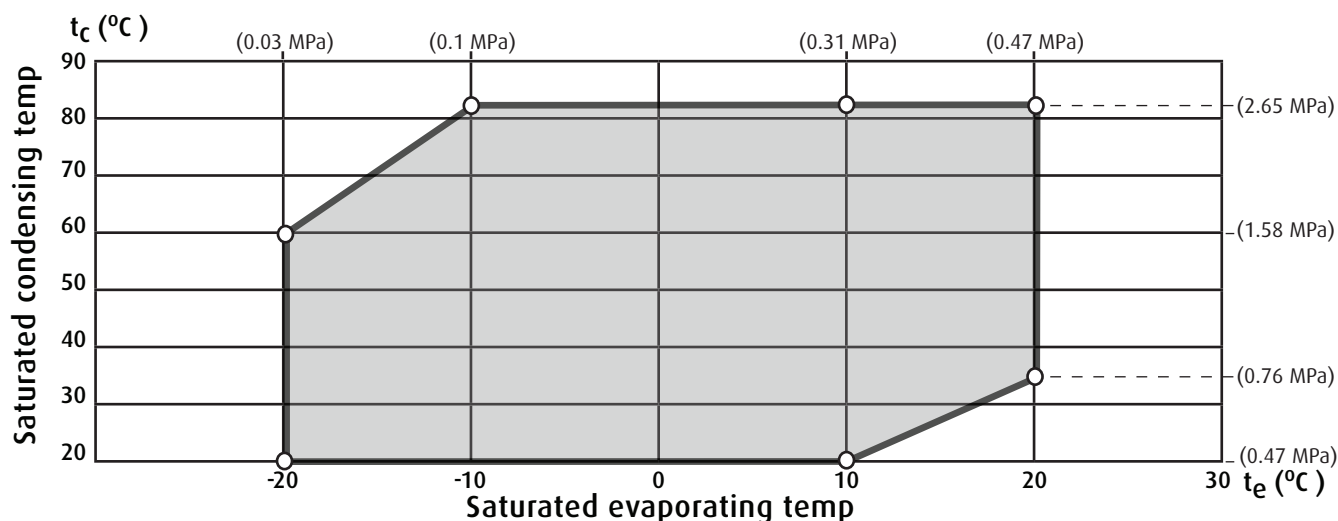

t_c : Condensing temperature (°C)
 t_e : Evaporating gas temperature (°C)

1- Product description - Compressor

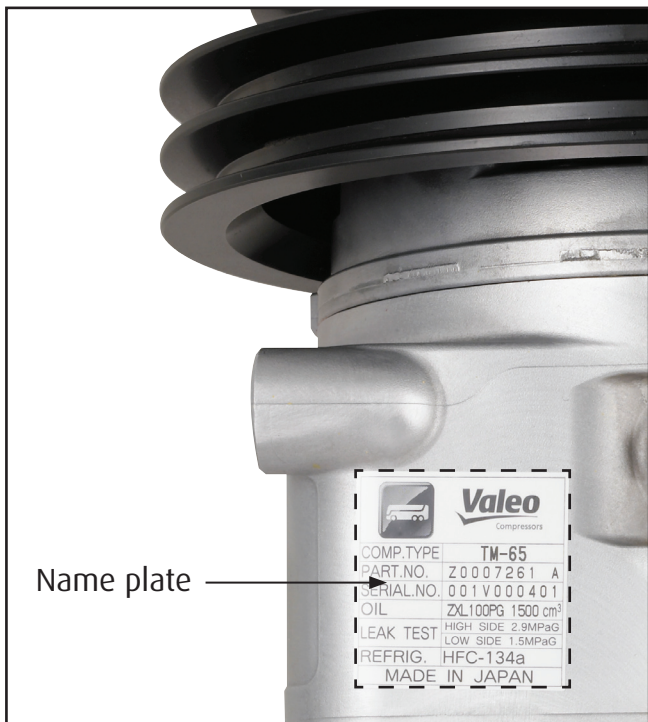

Name plate

To ensure that the compressor operates smoothly, be careful to respect the indications written on the name plate located on top of the compressor body.

	
COMP. TYPE	TM-XX
PART NO.	ZXXXXXXXX X
SERIAL NO.	XXXXXXXXXX
OIL	ZXL 100PG 1500 cm ³
LEAK TEST	HIGH SIDE 2.9MPaG
	LOW SIDE 1.5MPaG
REFRIG.	HFC-134a
MADE IN JAPAN	

Tip

As **TM-55 & TM-65** compressors have the same dimensions, the best way to differentiate them quickly is by referring to the name plate.

1- Product description - Magnetic clutch

Magnetic clutch

VALEO **TM-55 & TM-65** are available either as a compressor and magnetic clutch assembly or as a compressor body that customers can fit with compatible magnetic clutches. The magnetic clutch design Valeo has been promoting for more than 20 years is now gradually adopted as well by other major market actors.

Our compressors and magnetic clutches have successfully passed the thousand hours of long validation tests in Valeo Compressors research center laboratory. Operational excellence was demonstrated during hot season testing on field under challenging climates in the most stressful conditions.

Being able to rely on our robust magnetic clutch provides the best way to reduce fuel consumption without using additional unloading devices that decrease significantly the efficiency and durability of the compressor. The range of Valeo magnetic clutches ensures an unmatched reliability and the longest durability that perfectly matches the Valeo **TM-55 & TM-65** compressor qualities.

Specifications*

TECHNOLOGY	Electromagnetic single-plate dry clutch
RATED VOLTAGE	24V DC or 12V DC
CURRENT CONSUMPTION	50 W maximum
STATIC TORQUE	250 N.m {25.5 kgf.m, 184 ft.lbs}
DIRECTION OF ROTATION	Clockwise viewed from clutch
WEIGHT	Approx 10~12 kg {22-27 lbs}
V-BELT TYPE	V-groove (A or B) or V-ribbed (PK)

*The specifications may vary with the compressor.

Please also note that the maintenance procedures introduced in this service manual apply only to magnetic clutches provided by Valeo.

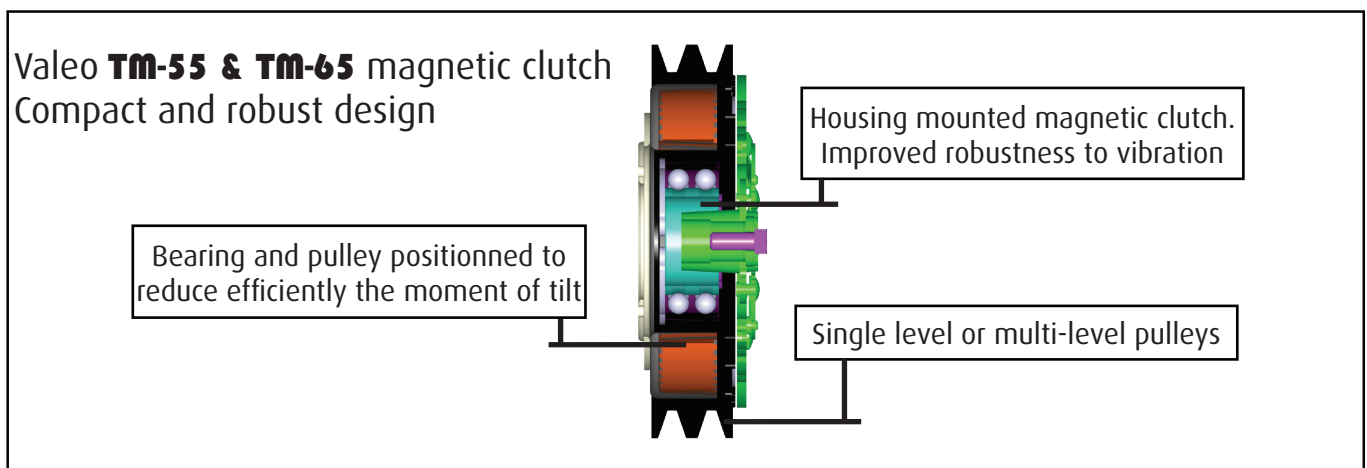

1- Product description - Connectors

Connectors

1. Fully open the shut-off valve when operating the compressor

- Unscrew the cap.
- Loosen the valve spindle seal by $\frac{1}{4}$ turn.
- Turn the spindle in the counterclockwise direction until it stops.

The shut-off valve is now fully opened and the service port connector is closed.

- When finished, tighten the valve spindle seal carefully and screw the cap.

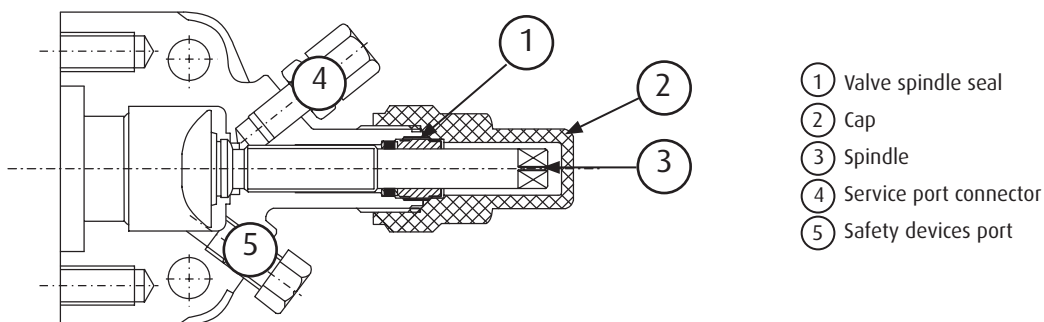

2. Open the service port connector when using a gauge manifold

- Turn the spindle in the clockwise direction by $\frac{1}{2}$ turn to 1 turn.

The shut-off valve and the service port connector are now opened.

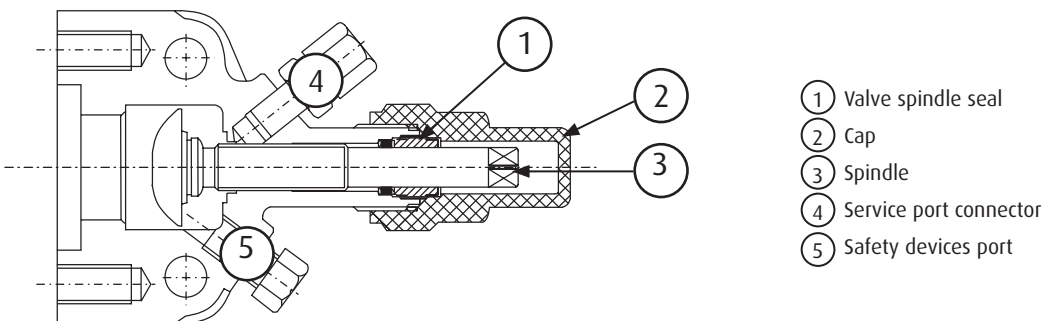

3. Fully close the shut-off valve when removing the compressor

- Turn the spindle in the clockwise direction until it stops.

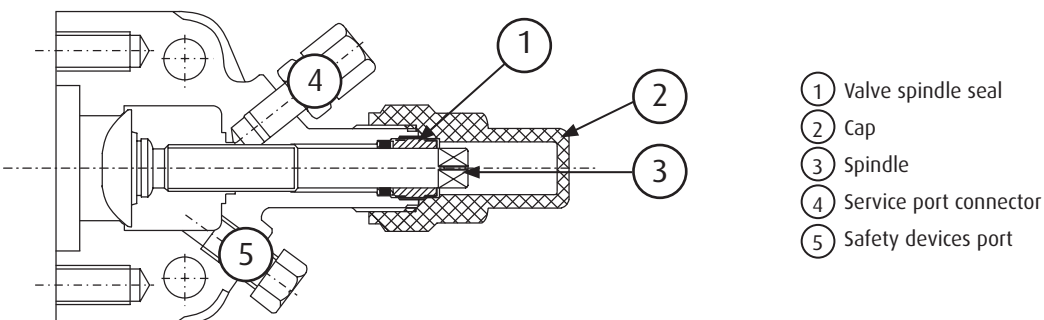

1- Product description - Performance

The performance data below were measured under the following conditions:

- Compressor speed: 1450 rpm
- Suction gas temperature: 20°C

Valeo **TM-55** performance data (R134a)

Conditions			Cooling capacity Q_0 (Watt)					
Cond. temp (°C)	Pd (MPa)	Evap temp (°C)	10	7.5	5	0	-5	-10
		Ps (MPa)	0.32	0.28	0.24	0.19	0.15	0.10
40	0.91	Q_0	38,077	33,734	29,352	23,921	19,864	15,139
50	1.21	Q_0	33,057	29,293	25,481	21,135	17,397	12,992
60	1.58	Q_0	28,314	25,027	21,655	17,620	14,425	10,554

Valeo **TM-65** performance data (R134a)

Conditions			Cooling capacity Q_0 (Watt)					
Cond. temp (°C)	Pd (MPa)	Evap temp (°C)	10	7.5	5	0	-5	-10
		Ps (MPa)	0.32	0.28	0.24	0.19	0.15	0.10
40	0.91	Q_0	42,880	37,190	34,060	28,190	22,510	17,300
50	1.21	Q_0	35,730	31,970	29,230	23,590	18,650	14,700
60	1.58	Q_0	30,650	27,800	24,870	19,860	15,500	11,970

Valeo **TM-55 & TM-65** conversion factors

Power data at different rotation speed can be approximated with conversion factors below.

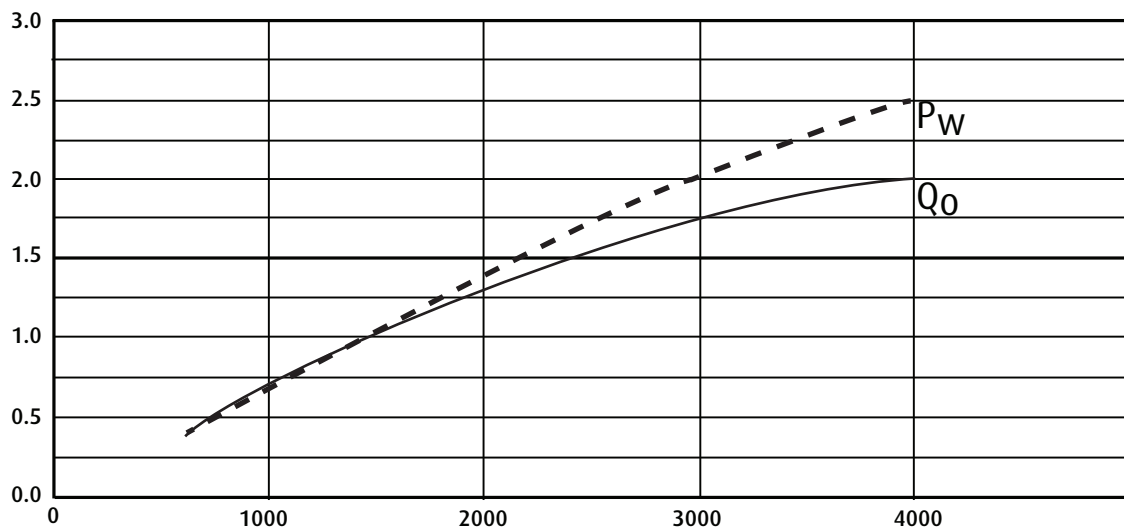

1- Product description - Dimensions

TM-55 & TM-65 compressors with magnetic clutch

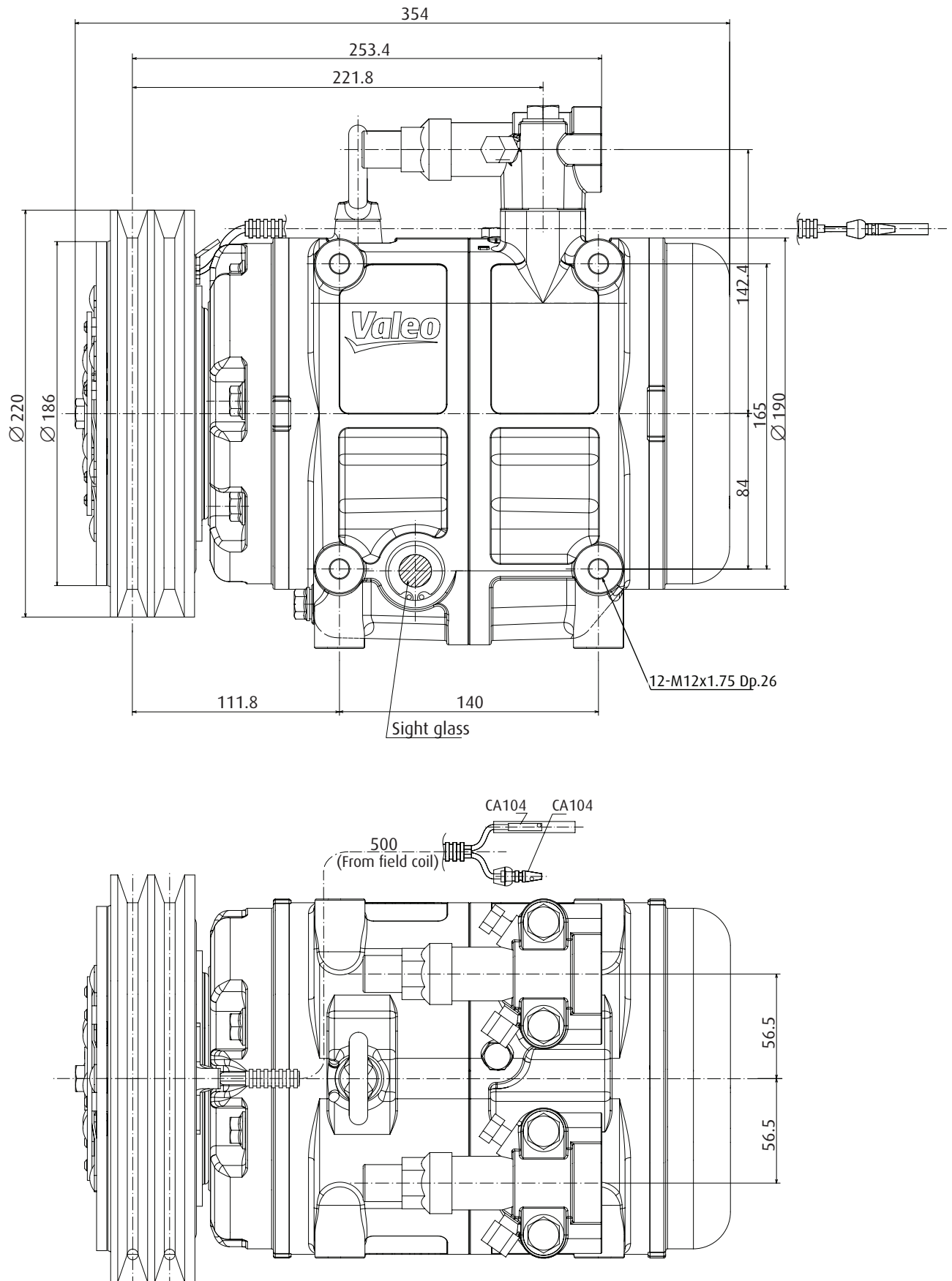

1-Product description - Dimensions

TM-55 & TM-65 compressors without magnetic clutch

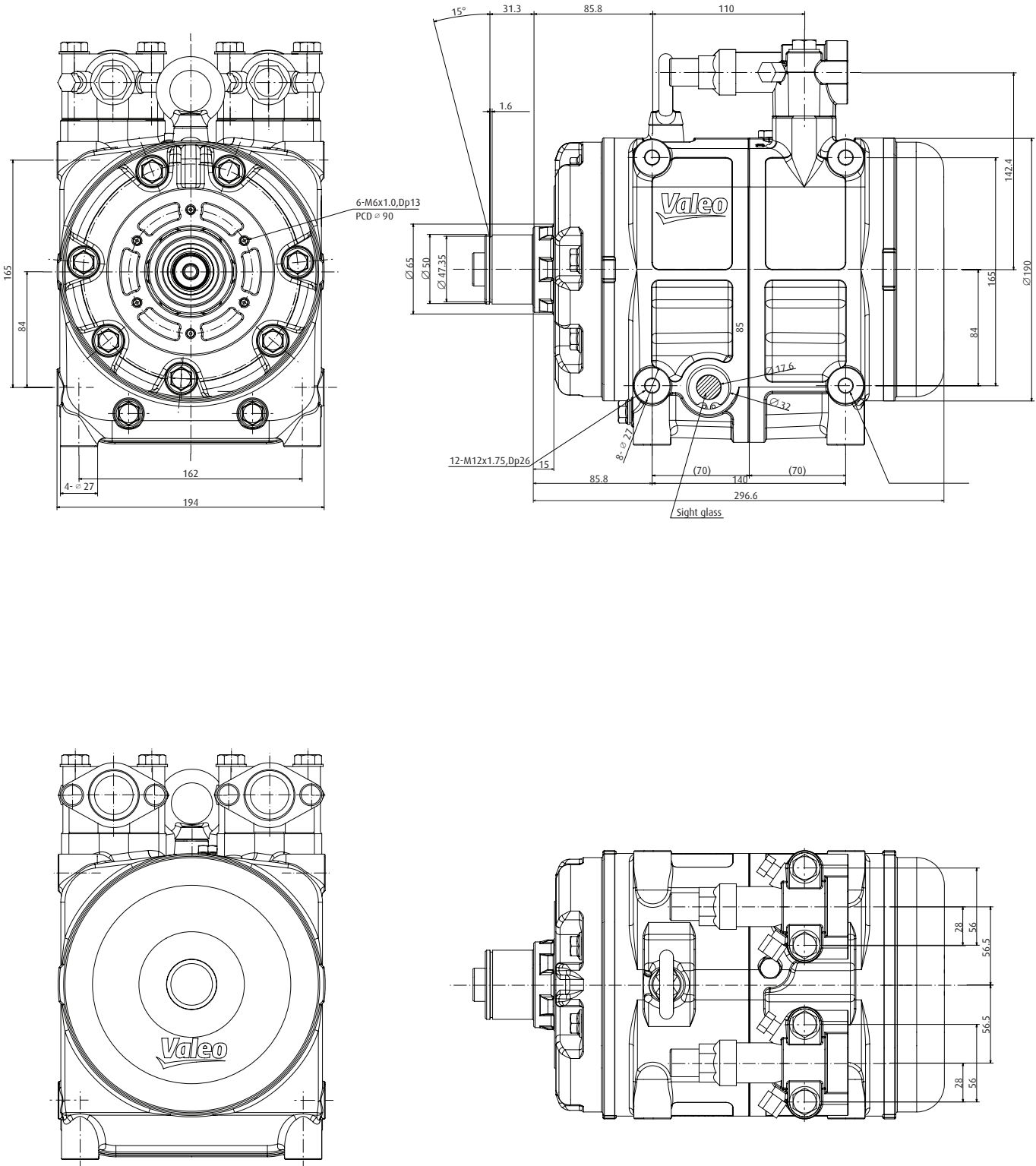

1- Product description - Exploded view

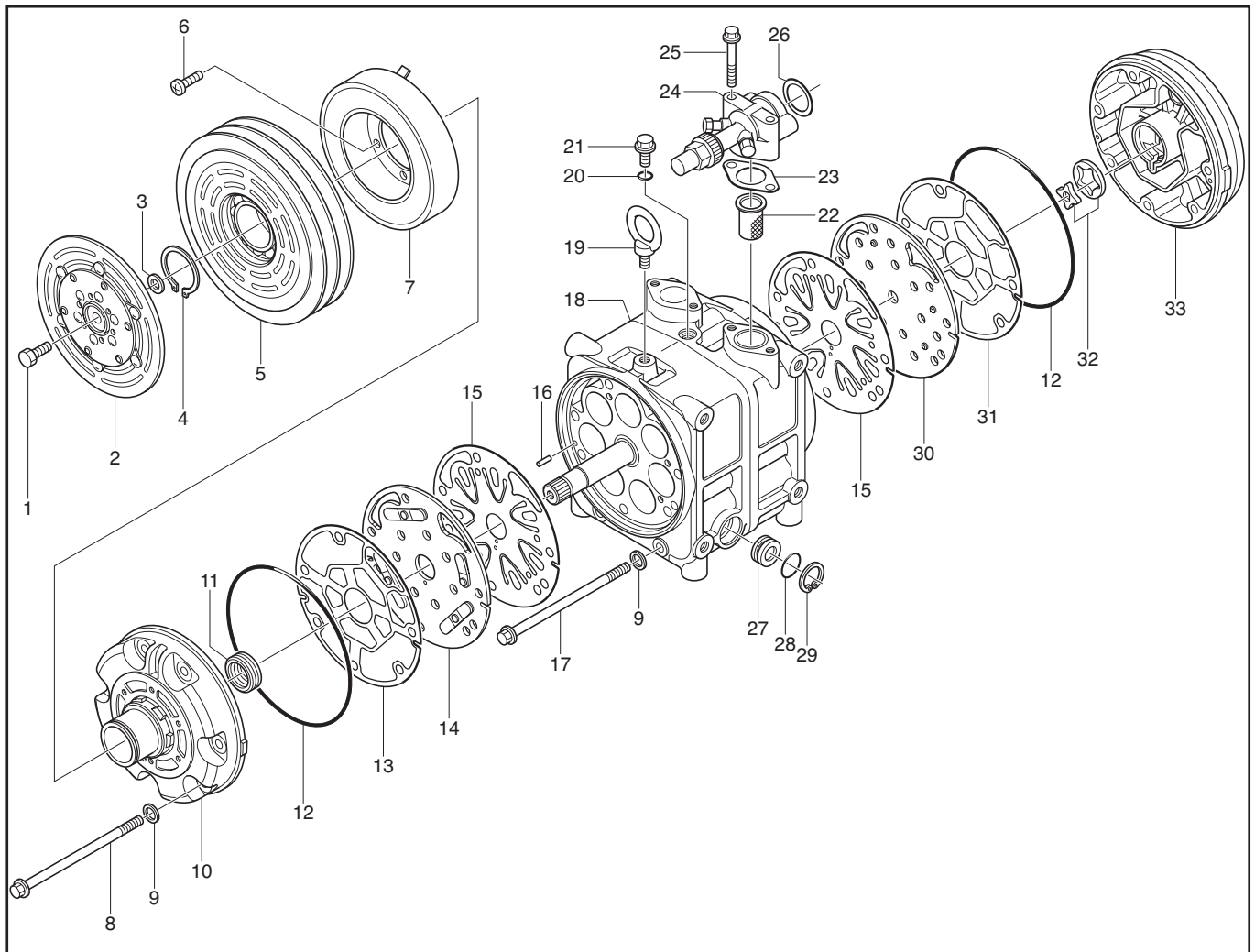

- | | |
|--------------------------|-----------------------------|
| 1. Center bolt | 18. Cylinder shaft assembly |
| 2. Armature assembly | 19. Eye bolt |
| 3. Adjusting shim | 20. O-Ring |
| 4. Snap ring | 21. Oil filler plug |
| 5. Pulley assembly | 22. Strainer |
| 6. Screw | 23. Gasket |
| 7. Field coil | 24. Connector |
| 8. Bolt | 25. Bolt |
| 9. Gasket | 26. Gasket |
| 10. Front cylinder head | 27. Sight glass |
| 11. Shaft seal assembly | 28. O-ring |
| 12. O-Ring | 29. Snap ring |
| 13. Gasket | 30. Valve plate assembly |
| 14. Valve plate assembly | 31. Gasket |
| 15. Suction valve | 32. Gear pump |
| 16. Pin | 33. Rear cylinder head |
| 17. Bolt | |

1- Product description - Swash plate system

Valeo **TM-55 & TM-65** are 14 cylinder swash plate type compressors. With this type of compressor, the cylinders and pistons are arranged axially along the drive shaft.

The pistons operate within the cylinders and are driven by a swash plate to perform suction, compression and discharge.

Swash plate system

The drive shaft, which is driven by the engine through the magnetic clutch, is equipped with a swash plate.

The drive shaft is supported by two radial bearings and two thrust bearings.

The swash plate is rotated by the drive shaft, and moves the pistons back and forth.

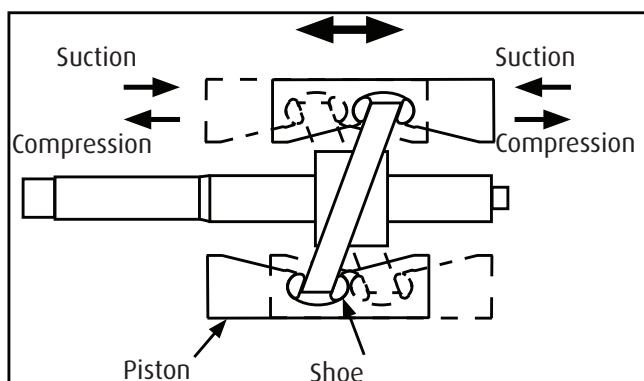
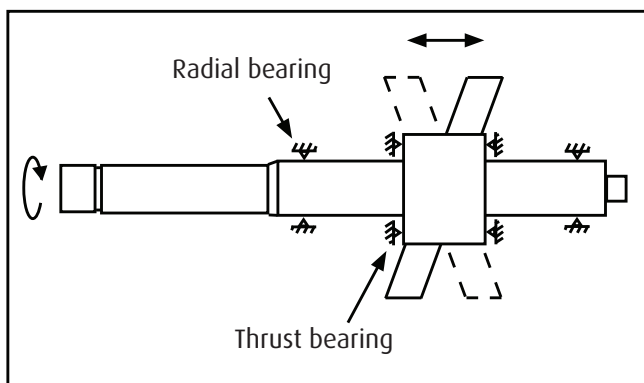
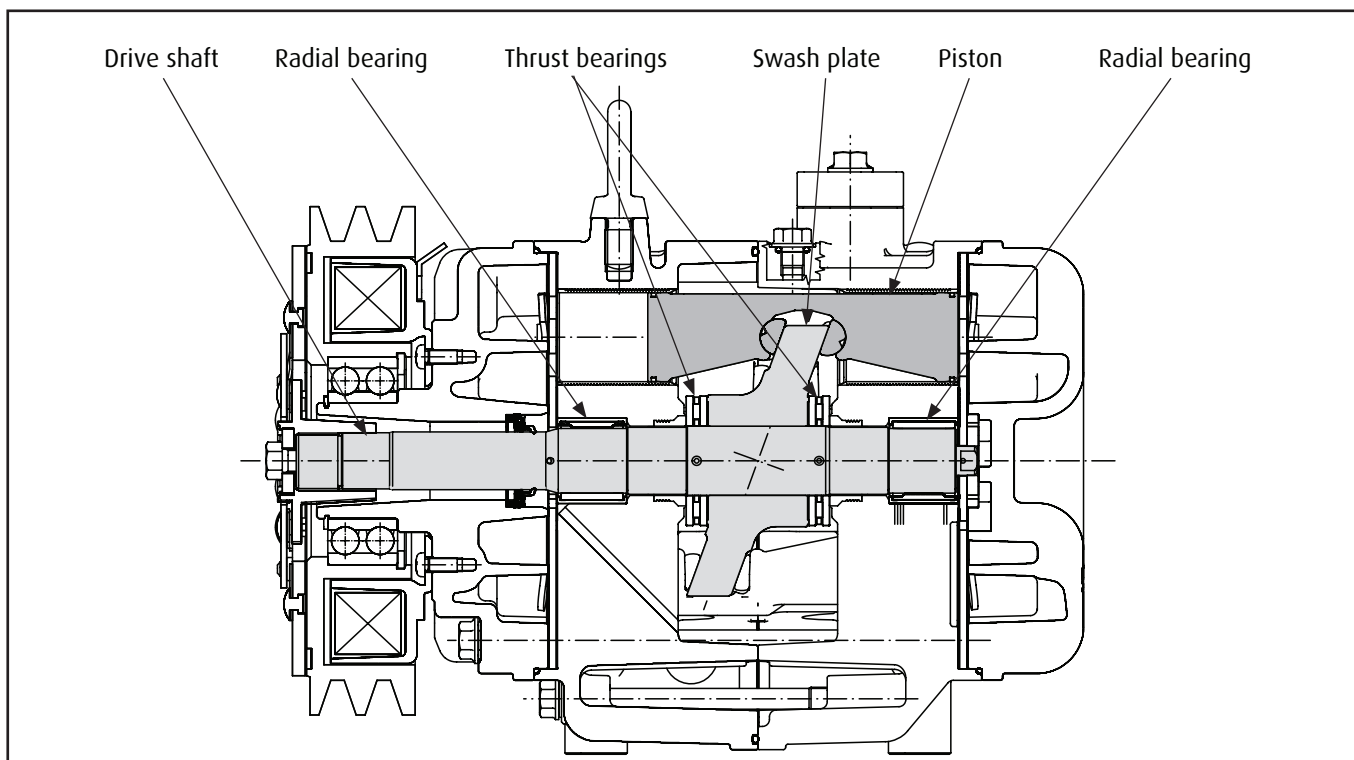

Piston Drive System

The pistons in the cylinders are mounted on the swash plate through hemispherical shoes.

Each piston has a compression head at each end. Swash plate rotation results in a reciprocating piston movement horizontal to the drive shaft.

The cylinders, which are arranged at 51.4° intervals around the drive shaft, are each divided into 2 chambers, providing 7 front and 7 rear bores.

As each piston performs suction and compression at either end, the compressor operates as a 14 cylinder compressor.

1- Product description - Lubrication

The gear pump situated at the end of the drive shaft draws oil from the oil reservoir and lubricates the parts of the compressor.

Oil flow

When the compressors start operating, the gear pump draws oil from the reservoir and pumps it through an oil passage in the shaft.

The oil then flows through ports in the shaft to lubricate the bearings and the shaft seal.

The area between the swash plate and the shoes is lubricated by the splashing action of the oil flowing through the thrust bearings.

The compressor remains constantly lubricated thanks to the oil circulating together with the refrigerant. Valeo compressor innovative internal design ensures that almost no oil remains mixed with the refrigerant that is flushed into the air conditioning system.

Refrigerant itself plays a lubricant role to prevent the compressor to be damaged in case of oil shortage.

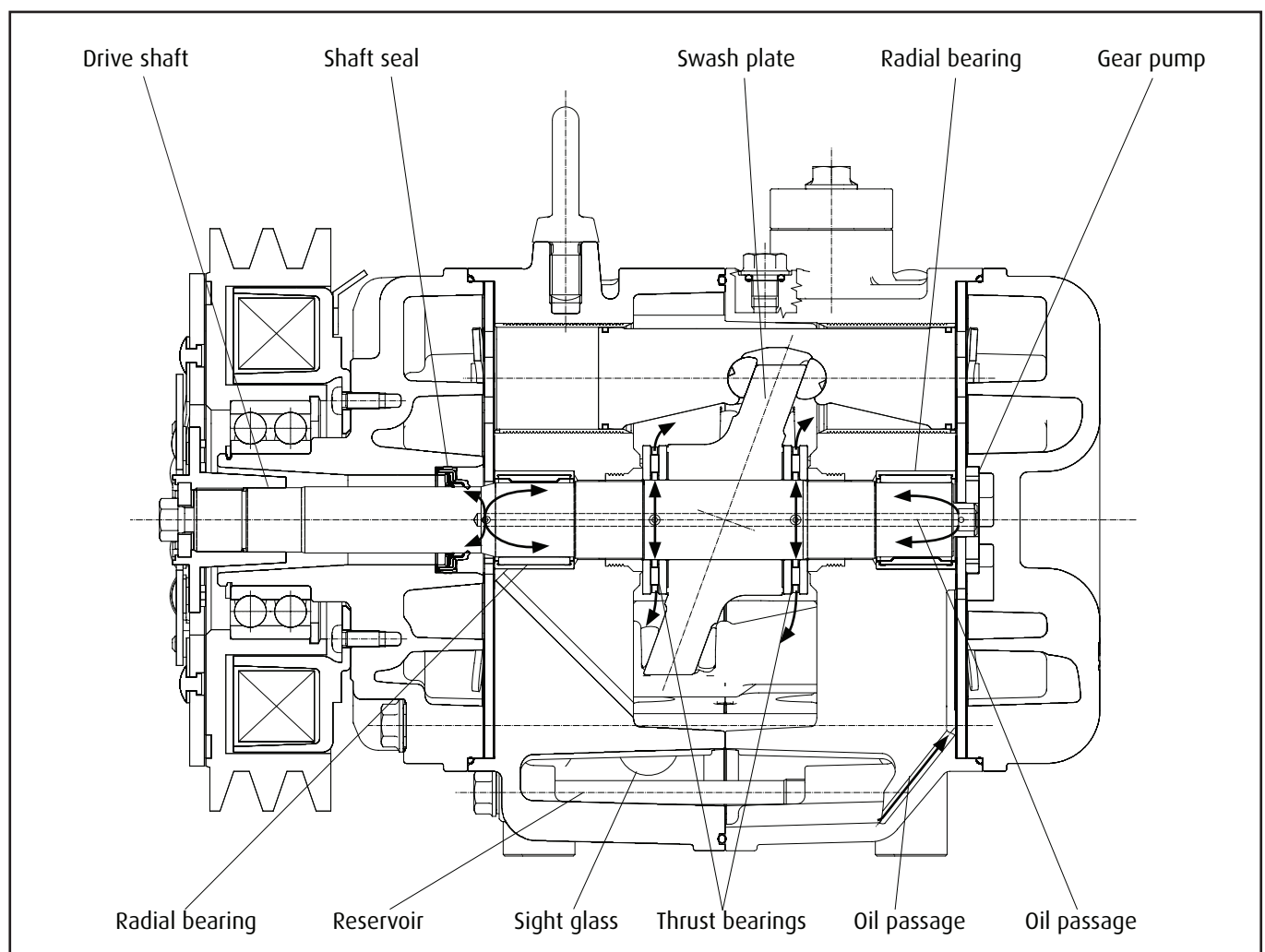

1- Product description

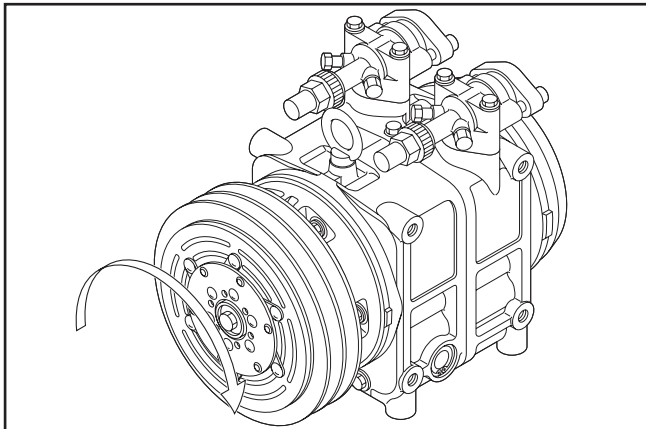

Compressor

1. The direction of rotation is clockwise as viewed from the clutch side.
2. The standard compressor oil charge is specified for bus air conditioners. The oil quantity may differ depending on the type and use of compressor. Please refer to the label on the compressor.

Operation condition table

Item	Condition
Surrounding temperature	Under 100°C (212°F)
Speed	Minimum: 600 r/min Maximum: 4500 r/min Continuous: 4000 r/min
Pressure	Maximum: 1.96 MPa {20kgf/cm ² , 284 psi}

3. The compressor must be operated under the conditions shown in the operation condition table shown at left.

CAUTION!!

The A/C cycle components must be designed so that the pressure in the cycle does not exceed 1.96 MPa {20 kgf/cm², 284 psi}

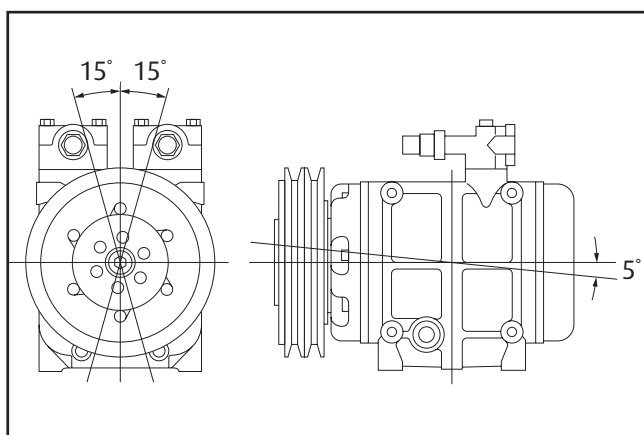

4. Inclination limit at installation
The compressor must be installed on the vehicle within the range shown at left.

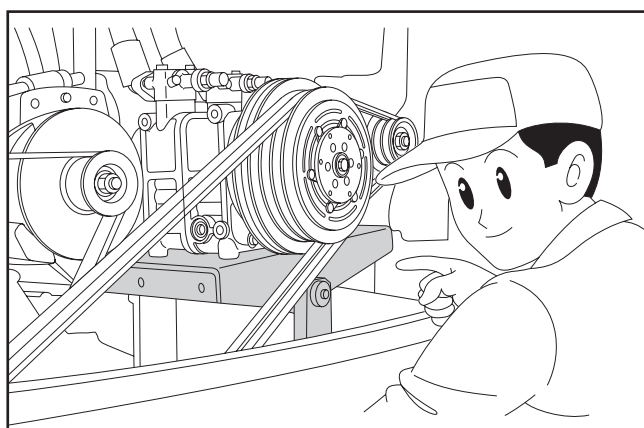

Compressor bracket

1. Install the bracket securely on the chassis frame or engine body. As the engine vibrations may be severe, the bracket and mounting bolts must be installed securely.
2. Vibration resistance
There must not be any resonance under 250 HZ.

1- Product description

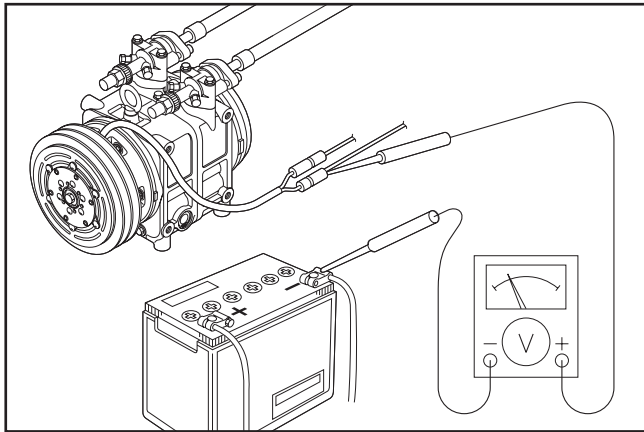

Magnetic clutch

1. Voltage

DC 24 V

The terminal voltage of the magnetic clutch must exceed 21 V.

DC 12 V

The terminal voltage of the magnetic clutch must exceed 10.5 V.

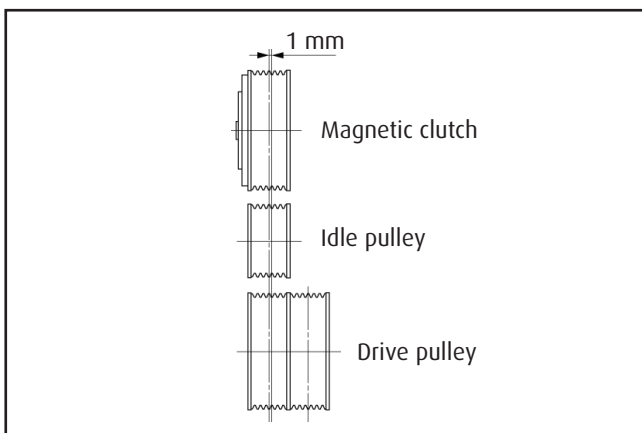

2. Ratio of magnetic Clutch to drive pulley

- When the compressor is driven from the pulley drive of the vehicle, the magnetic clutch to drive pulley must not exceed the range 1: 0.92-1.08 to avoid vibration and resonance.
- Compressor speed must not exceed the specified speed.

CAUTION!!

Pulley ratio is the ratio of the magnetic clutch diameter to the drive pulley diameter.

3. Pulley alignment tolerance is less than 1mm (0.04 in).
4. Pulley groove: V-groove or V-ribbed.
5. The V-belt tension must be adjusted to the tension specified by the belt maker.

2- Operation precautions

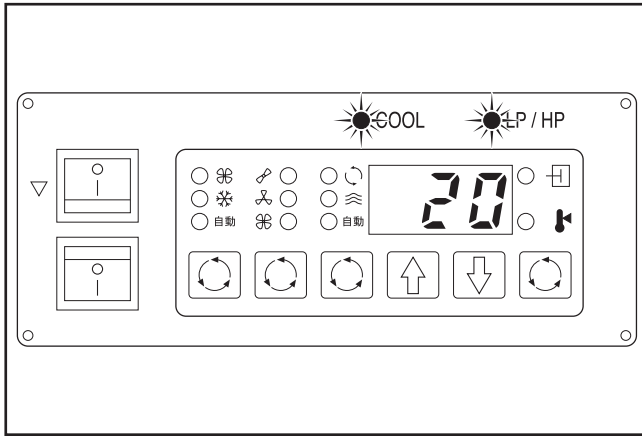

1. In the off season of air conditioner, operate the compressor for a few minutes from time to time.
2. Do not drive through water. Water may damage the magnetic clutch, thus preventing normal operation.
3. Always charge the A/C system with the specified quantity of refrigerant.

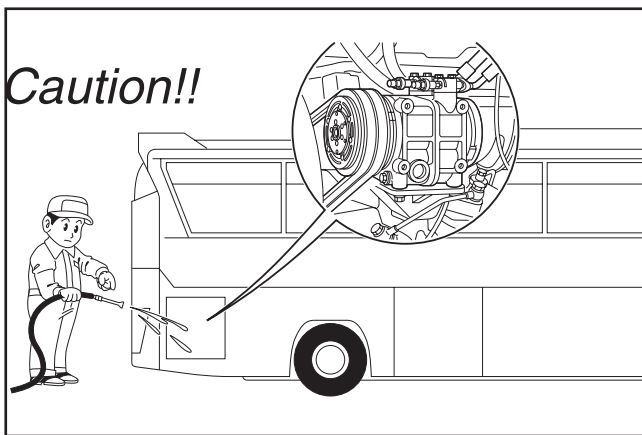

4. Keep the compressor clear of water projection while cleaning the vehicle.

3- Handling instructions

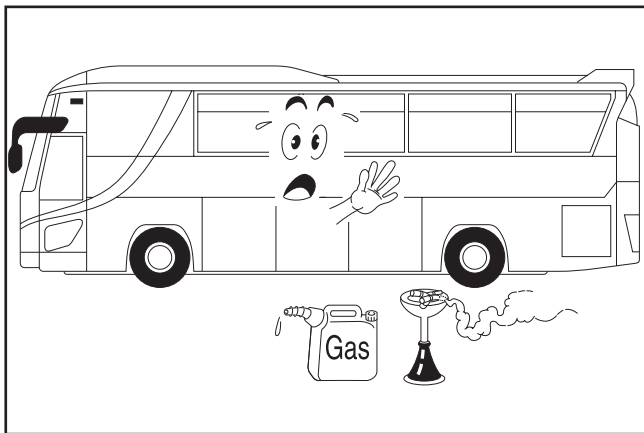
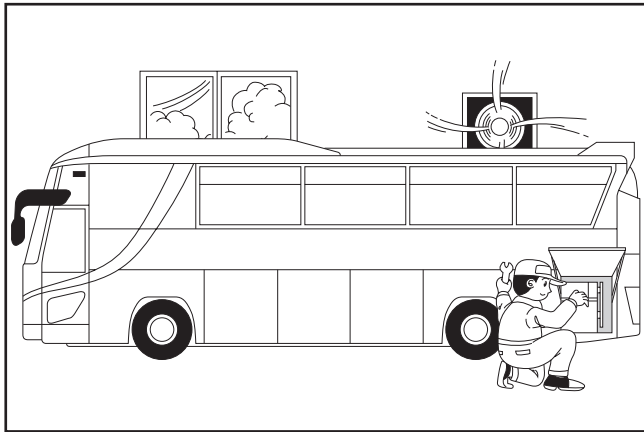

Maintenance precautions

Work area

Because the components of air conditioners are especially sensitive to moisture, dirt and rust, always observe the following:

- Work indoors whenever possible
- Select a flat ground work area
- Keep the work area clean
- Select a work area with adequate ventilation.

CAUTION!!

Refrigerant itself is not harmful, but excessive accumulation in a closed area can cause oxygen deficiency.

- Keep naked flame and inflammable away from the vehicle in which the air conditioner is being installed.
(Fire is especially dangerous during the gas leak inspection following installation)

WARNING!!

Contact with flame and high temperatures can generate toxic gases.

Refrigerant handling

WARNING!!

Direct contact with refrigerant can cause frostbite or blindness.

Always wear safety glasses and protective gloves.

Do not work with refrigerant close to your face.

1. Do not mistake refrigerants

If an HFC-134a air conditioning system is mistakenly charged with another refrigerant, serious problems such as compressor seizing may occur. Therefore, confirm before charging with refrigerant that the type of air conditioning system is an HFC-134a system.

3- Handling instructions

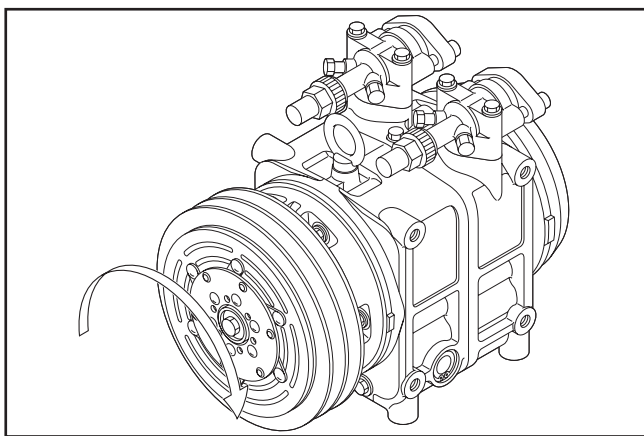
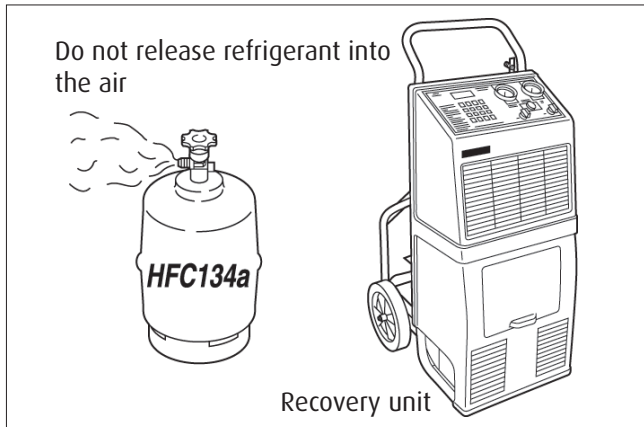

2. Do not release refrigerant into the air

Although HFC-134a is not subject to CFC regulations, it can have effect on global warming and so should not be released into the air. When removing refrigerant from the air conditioner system, always use a refrigerant recovery unit made especially for HFC-134a.

Compressor handling

Do not strike, drop or turn unnecessarily the compressor upside down. If the compressor is knocked over or turned upside down, rotate the magnetic clutch 5 or 6 times by hand to circulate the oil in the cylinder.

Sudden rotation with the oil still in the cylinder can cause valve damage and adversely affect durability.

Compressor removal

When the compressor is operational

1. Perform the oil return operation (see p.18).
2. Recover the refrigerant from the system using a refrigerant recovery unit.
3. Remove the compressor.
4. Drain the oil from the compressor and close all open connections immediately.
5. Check the oil quantity and the degree of contamination (see p.19).

When the compressor is inoperable

1. Recover the refrigerant from the system using a refrigerant recovery unit if the shut-off valves are removed with the compressor.
2. Remove the compressor.
3. Drain the oil from the compressor and close all open connections immediately.
4. Check the oil quantity and the degree of contamination (see p.19).

3- Handling instructions

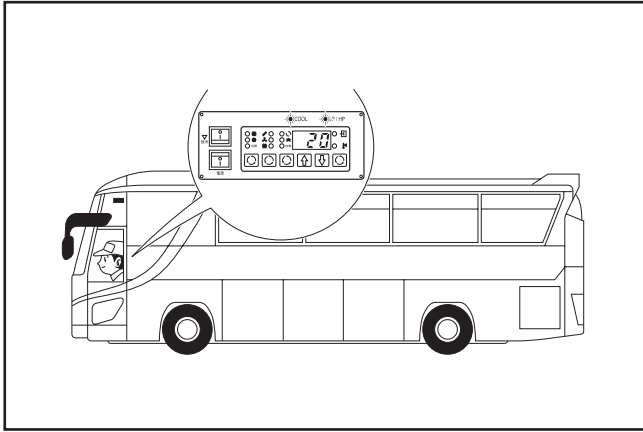

Oil return operation

Compressor oil mixed with refrigerant is circulating in the air conditioning system.

Perform the oil return operation to return this oil to the compressor before removing components from the system.

1. Open the doors and windows and operate the blower motor at maximum speed.
2. Operate the vehicle engine at idling during at least 20 minutes.

Note: The maximum amount of oil cannot be recovered at higher speeds. This operation also requires a warm ambient temperature.

Oil handling

Oil specification

Use only ZXL 100PG (DH-PS) or POE oil.

Oil quantity inspection

There is no particular need for frequent inspection or replacement, although the oil must be inspected or replaced in the following cases :

- At the start of the season.
- Every 5,000 km (3,200 miles) or every 5 months for vehicles that are in constant use.
- When gas leaks from hoses or pipes.
- When gas or oil leaks from the compressor.
- When there is any malfunction other than the above.
- When the evaporator, condenser or receiver drier is replaced.
- When refrigerant is suddenly discharged from the system.

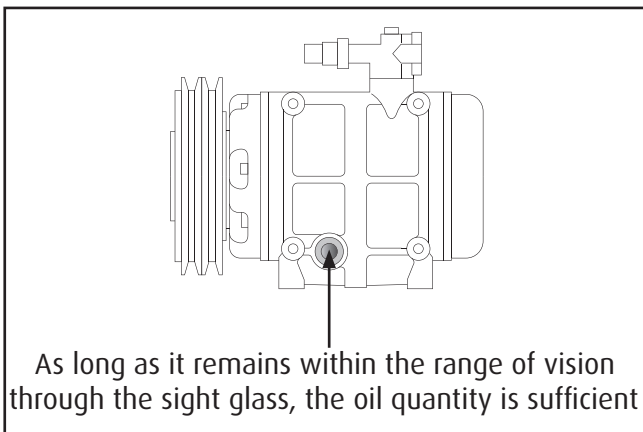

Handling precautions

1. The oil must be free from dust, metal filings, etc.
2. Do not mix oils.
3. The moisture content must not exceed 1,000 ppm. (PAG oil only)
4. The oil easily absorbs moisture when the container is open. Therefore always seal the container immediately after use. (PAG oil only)

3- Handling instructions

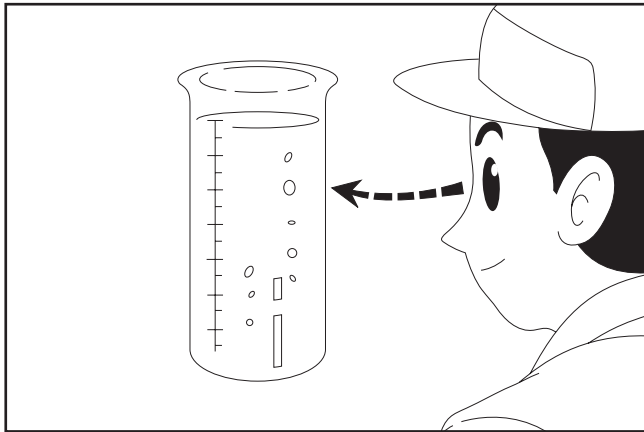

Oil contamination

Unlike engine oil, no cleaning agent is added to the compressor oil. Even if the compressor is run for a long time, the oil never becomes turbid as long as there is nothing wrong with the compressor or its method of use. Inspect the extracted oil for any of the following.

- Increased opacity of the oil.
- Color change to red
- Presence of foreign matter, metal filings, etc.

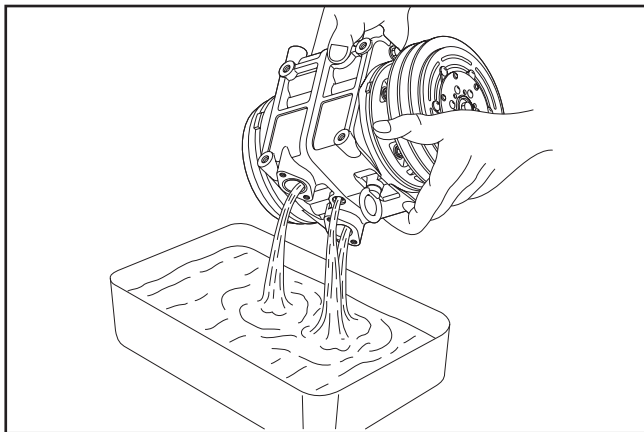

Oil check

The compressor oil must be checked as follows when being charged into a used system.

1. Perform the oil return operation (p.18).
2. Remove the compressor from the vehicle.
3. Remove the oil filler plug and drain the oil through the oil filler plug and the high and low pressure connectors.
4. Check the oil for contamination.
5. Fill the compressor with the specified amount of oil (p.20)

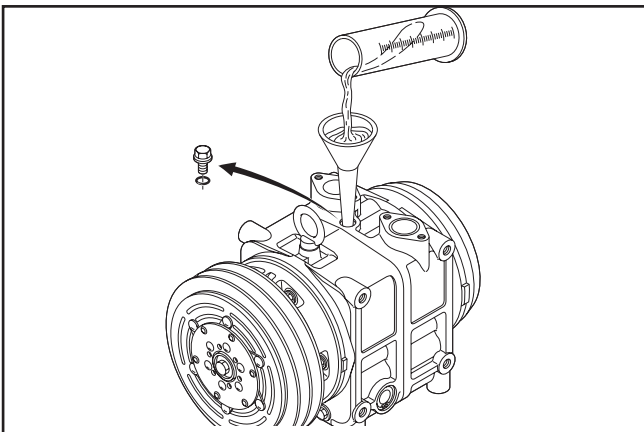

3- Handling instructions

unit: cm³ & cc

Specified charge	Amount recovered	Charging amount	Amount to remove from new compressor
1500	1000 or more	Same as recovered	1500 - (amount recovered)
	Under 1000	1000	500

unit: cu in

Specified charge	Amount recovered	Charging amount	Amount to remove from new compressor
91.5	61 or more	Same as recovered	61 - (amount recovered)
	Under 61	61	30.5

CAUTION!!

The specified oil quantity differs, depending on the type of air conditioner system. A label describing the specified quantity is attached to the compressor. Additionally, all of the oil cannot be removed when draining the compressor as some remains as an oil film on the inside of the compressor and the system components. Therefore, refer to the table at left when recharging the compressor with oil. Excess oil adversely affects the cooling capacity and the compressor.

1. Install the oil filler plug and tighten it to the specified torque.

Specified torque: 15 - 18 N.m
{1.5 - 1.8 kgf.m, 11 - 13 ft.lbs}

CAUTION!!

The oil filler plug O-ring must be replaced with a new one.

Replacement of components

When replacing the component parts of the system, supply the following amount of oil to the compressor.

Component mounted	Amount of oil
Evaporator	300 cm ³ (18.3 cu in)
Condenser	200 cm ³ (12.2 cu in)
Receiver drier	100 cm ³ (6.1 cu in)
Pipe or hose	100 cm ³ (6.1 cu in)

After installing these component parts, check the compressor oil. Refer to page 18.

3- Handling instructions

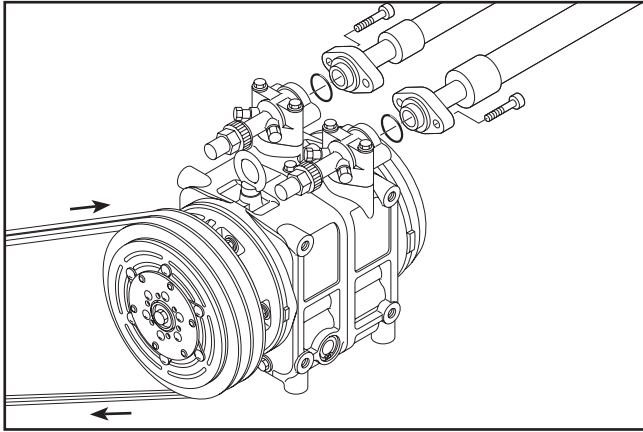

Running-in operation

Whenever moving parts have been replaced, it is necessary to run-in both the compressor and the magnetic clutch.

Compressor running-in

Reassembled compressors must be run-in after the leak test (see next page).

1. Check that the compressor contains the specific amount of oil.
2. Install the compressor on the test bench.
3. Install the high pressure connector and the low pressure connector to the ports and tighten the bolts to the specified torque.

**Specified torque: 25 - 32 N.m
{2.5 - 3.3 kgf.m, 18 - 24 ft.lbs}**

4. Connect the two connector ports using a flexible hose.
5. Run the compressor at 1,000 rpm for at least 30 minutes.
6. Replace the oil.
7. Repeat the leak test.

CAUTION!!

While the compressor is being run-in in step 5 above, check the outside temperature of the front head. If the temperature exceeds 80°C (176°F), stop the running-in operation. Resume the operation when the head has cooled.

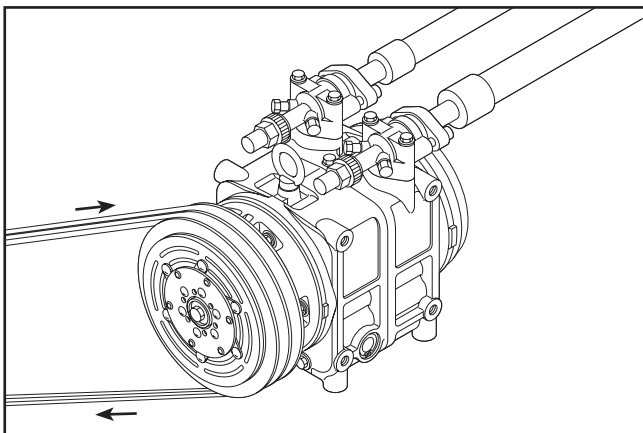

Magnetic clutch running-in

1. Install the clutch on the compressor.
2. Install the compressor on the test bench, and operate the compressor by running the system.
3. Maintain the compressor speed at 700 rpm. Operate the A/C switch through the ON/OFF cycle at least 50 times ("ON" for 10 seconds and "OFF" for 10 seconds).

3- Handling instructions

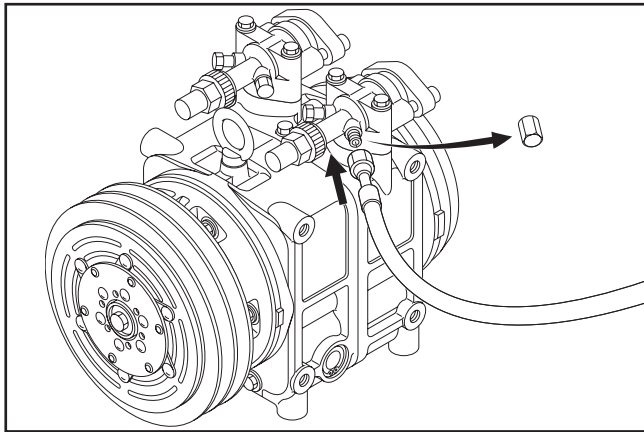

Leak test

The compressor must be checked for refrigerant leaks after it is repaired. The procedure is as follows.

1. Fit the connectors to the suction and discharge connections, and tighten it to the specified torque.

Specified torque: 25 - 32 N.m
{2.5 - 3.3 kgf.m, 18 - 24 ft.lbs}

2. Fill the compressor with refrigerant through the suction side, raising the refrigerant pressure to at least 0.49 MPa {5 kgf/cm², 71 psi}.
3. Check the compressor for leaks using a leak detector.

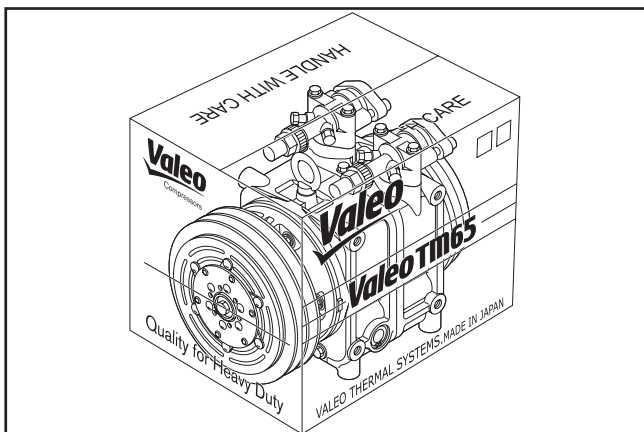
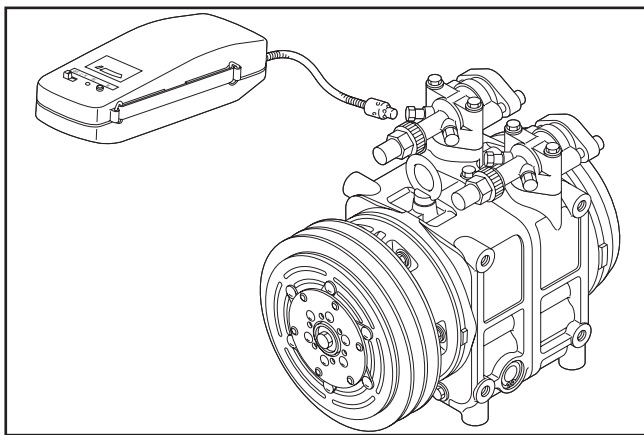

Storing a repaired compressor

If it is necessary to store a repaired compressor for some time before installation, evacuate the compressor and fill it with dry nitrogen gas through the suction fitting to raise the pressure to 30 ~ 100 kPa {0.3 - 1.0 kgf/cm², 4.4 - 14.5 psi}.

4- Trouble shooting

Compressor trouble shooting

When a trouble occurs during the compressor operation, it is often difficult to pinpoint exactly the cause of the malfunction.

As long as the compressor maintenance is done correctly, there should not be any problem throughout the whole vehicle life, but in case it ever happens, we hope this trouble shooting can help you solve the issue efficiently.

Below are listed most of the troubles you may encounter while the A/C is ON.

Please refer to the compressor trouble shooting arborescence to localize the malfunction symptom, then look at the table (p.24 - 25) for the appropriate measure.

Most of the malfunction symptoms can be classified in the following categories:

1. Insufficient cooling capacity
2. Abnormal noise
3. Smoke

In case of insufficient cooling capacity, we recommend that you prepare a gauge manifold to measure the pressure of both discharge and suction sides (for a detailed diagnosis by gauge pressure, see p.26 - 27).

Compressor trouble shooting arborescence

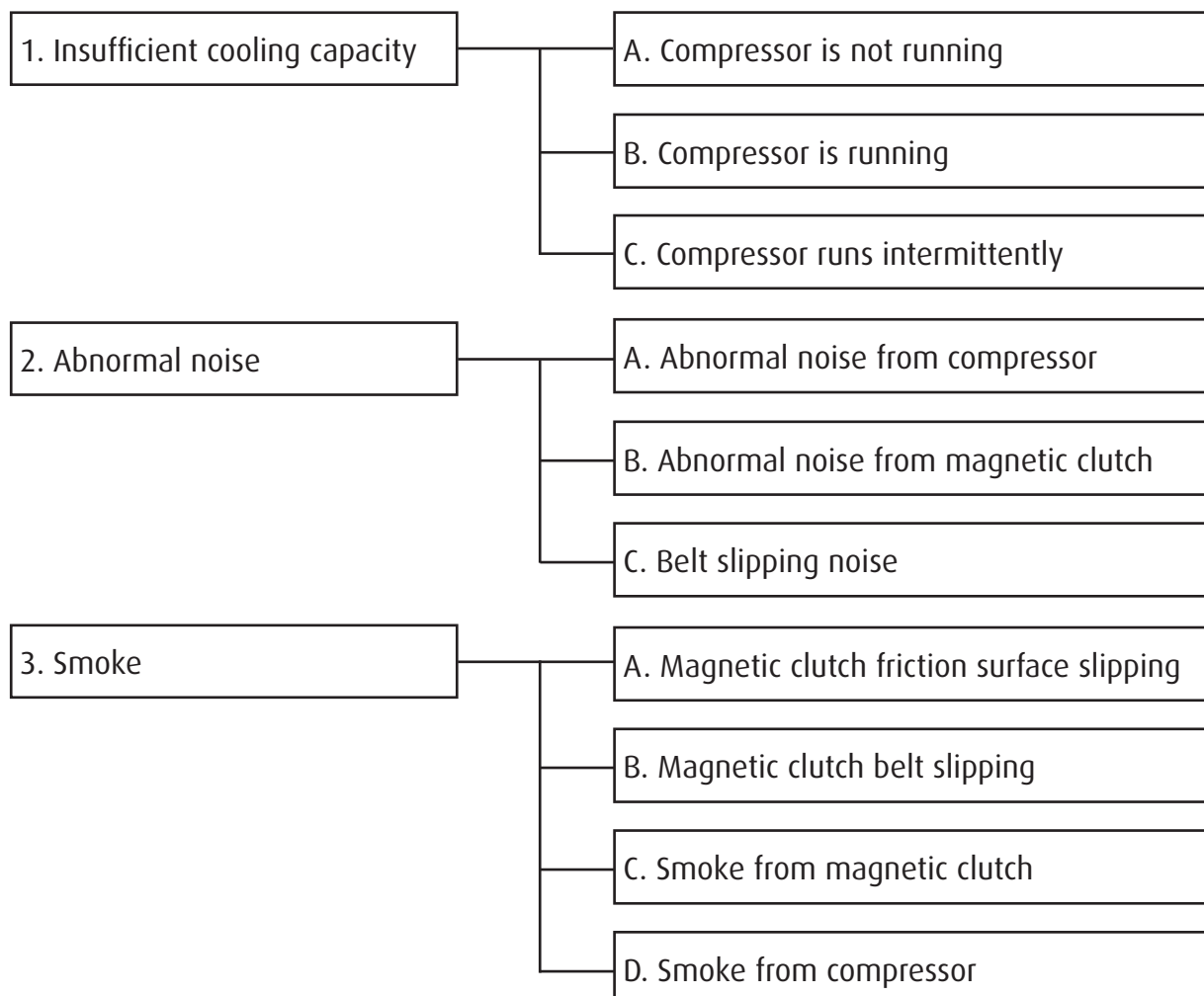

4- Trouble shooting

1. Insufficient cooling capacity

	Trouble	Symptom	Possible cause	Measure
A	Compressor is not running (No cool blow coming out)	Magnetic clutch slips when turning on the A/C switch	Compressor internal part damage	Replace the compressor
		Low pressure cut switch operate (see p.26 - 27)	Refrigerant shortage	Fix the refrigerant leakage then fill with refrigerant until having the right amount
		The magnetic clutch slips or does not engage when the compressor runs	Lead wire short circuit or wiring connector not seated properly	Replace the lead wire if it is defective
			Magnetic clutch damage	Repair or replace the magnetic clutch
			Magnetic clutch air gap too wide	Adjust air gap or replace magnetic clutch
			Low magnetic clutch voltage	Charge battery
		The magnetic clutch engages but the armature does not rotate	Belt slipping	Replace the compressor if it is locked
		Belt run off the pulley	Compressor internal part damage or magnetic clutch damage	Replace the compressor or the magnetic clutch
Center bolt is loose / Center bolt is missing	Bolt drop off/ Armature drop off	Replace magnetic clutch		
B	Compressor is running (No cool blow coming out)	Compressor is running normally	Poor compression	Replace the compressor
		No difference of temperature between discharge side and suction side (see p.26 - 27)	Refrigerant shortage	Fix the refrigerant leakage then fill with refrigerant until having the right amount
		The magnetic clutch slips or does not engage when the compressor is running	Magnetic clutch friction surface slipping	Charge the battery or replace the magnetic clutch
			Loose connection of the magnetic clutch electrical circuit	Replace the magnetic clutch after making sure it is defective
		Belt slipping	Magnetic clutch belt slipping	Belt tension readjustment
		The magnetic clutch does not engage	Defective sensor	Replace the sensor after making sure it is defective
C	Compressor runs intermittently (Cool blow comes out only from time to time)	Both discharge and suction pressures are high	Excess of refrigerant	Reduce the refrigerant charge until reaching the right amount
			Condenser fan failure	Replace the condenser after making sure it is defective
		The magnetic clutch slips or does not engage when the compressor is running	Loose connection of the magnetic clutch electrical circuit	Replace the magnetic clutch after making sure it is defective
		The magnetic clutch does not engage	Defective sensor	Replace the sensor after making sure it is defective

4- Trouble shooting

2. Abnormal noise

	Trouble	Symptom	Possible cause	Measure
A	Abnormal noise from the compressor	Abnormal vibration after turning on the A/C switch	Compressor installation bolt is loose	Increase tightening torque of the loose bolts
			Wide gap at the attaching portion between the compressor and the bracket	Improve the compressor attaching portion
		Abnormal noise from the compressor body	Compressor body internal component damage	Replace the compressor
B	Abnormal noise from the magnetic clutch	The magnetic clutch has a backlash and slips	Magnetic clutch damage	Replace the magnetic clutch
		Strange noise when the magnetic clutch engages	Air gap too wide	Adjust air gap or replace magnetic clutch
		Armature slips / does not engage when the compressor is running	Magnetic clutch friction surface slipping	Charge battery or replace magnetic clutch
C	Abnormal noise from the magnetic clutch	Armature does not rotate when magnetic clutch engages	Belt slipping	Replace the compressor if locked. Readjust the belt tension if the belt is loose

3. Smoke

	Trouble	Symptom	Possible cause	Measure
A	Magnetic clutch friction surface slipping	The magnetic clutch slips / does not engage when the compressor is running	Magnetic clutch air gap too wide	Adjust air gap or replace magnetic clutch
			Low magnetic clutch voltage	Charge battery
			Magnetic clutch friction surface is greasy	Clean friction surface or replace magnetic clutch
B	Magnetic clutch belt slipping	The magnetic clutch slips / does not engage when the compressor is running	Belt alignment is not correct	Adjust the compressor installation position
			Magnetic clutch belt is greasy	Clean or replace the belt
			Magnetic clutch belt tension is loose	Adjust belt tension
C	Smoke from the magnetic clutch	The magnetic clutch does not engage	Coil open or shorted	Replace the magnetic clutch
D	Smoke from the compressor	Refrigerant / oil is billowing out	Refrigerant leaking, uncoupled piping or piping burst	Fix the refrigerant leakage then fill with refrigerant until having the right amount

4- Trouble shooting

A/C cycle diagnosis by gauge pressure

Following is a diagnosis procedure to connect gauge manifold to A/C cycle, measure suction and discharge pressures and analyze the defects of the cycle.

Operation conditions of the A/C cycle for pressure measuring:

1. Ambient temperature: 30 - 35 °C
2. Engine speed: 1,500 rpm
3. A/C switch: ON
4. Blower speed: high
5. Temperature control: full cold

Gauge pressure indication	Cause	Confirmation method	Action to take
Pressure is normal	A/C cycle operates normally. If there is any defect (poor cooling performance), there shall be another cause <div style="border: 1px solid black; padding: 5px; margin: 10px auto; width: fit-content;"> Discharge pressure: around 1.0 - 1.7 Mpa (10 - 17 kgf/cm²) Suction pressure: around 0.13 - 0.20 Mpa (1.3 - 2.0 kgf/cm²) </div>		
Both discharge and suction pressures are low <div style="border: 1px solid black; padding: 5px; margin: 10px auto; width: fit-content;"> Suction pressure becomes vacuum </div>	Refrigerant shortage	Connect gauge manifold to cycle	Recover refrigerant, then refill with the right amount of refrigerant
	Receiver dryer is clogged	Temperature difference between inlet and outlet pipes happens. Dryer is covered with frost	Replace parts
	Expansion valve is clogged	Expansion valve was covered with frost	Clean or replace part
	Enclosure leakage from TXV temperature sensing tube. (TXV operates to close the valve opening)	Outlet side of TXV is not cooling. (Low side of gauge indicates vacuum)	Replace part
	Temperature sensing device at outlet air is defective	Evaporator becomes frozen up	Adjust or replace the part
	Refrigerant piping is clogged or crashed	If any part between the dryer and the compressor is clogged or crashed, the low side pressure becomes vacuum	Adjust or replace the part

4- Trouble shooting

Gauge pressure indication	Cause	Confirmation method	Action to take
Both discharge and suction pressures are high	Excess of refrigerant	Connect gauge manifold to cycle	Recover refrigerant, then refill with the right amount of refrigerant
	Condenser cooling malfunction	Condenser becomes muddy and fins are clogged and collapsed. Defect of cooling fan rotation. Malfunction of fan motor for condenser.	Clean up, hand repair of fin and replacement
	Misaligned TXV or thermal sensing tube of TXV is not fit on regularly. (Excess opening of TXV)	Defective refrigerant flow control, the thermal sensing tube is not closely in contact with the evaporator pipe	Adjustment or replacement
	Air mixed in refrigeration cycle	Just after compressor stops, discharge pressure will come down immediately to 0.29 - 0.39 MPa (3 - 4 kgf/cm ²)	Evacuate air from cycle, the charge with the adequate amount of refrigerant.
Discharge pressure is high and suction pressure is low	Refrigerant cycle is clogged between compressor and condenser	Appreciable temperature difference at the clogged location	Clean up inside the cycle or replace the part
Discharge pressure is low and suction pressure is high	Defect of the compressor valve or gasket	Discharge and suction pressures balance immediately after the compressor stops. (Defective compression of compressor)	Replace the compressor

5- Tightening torques

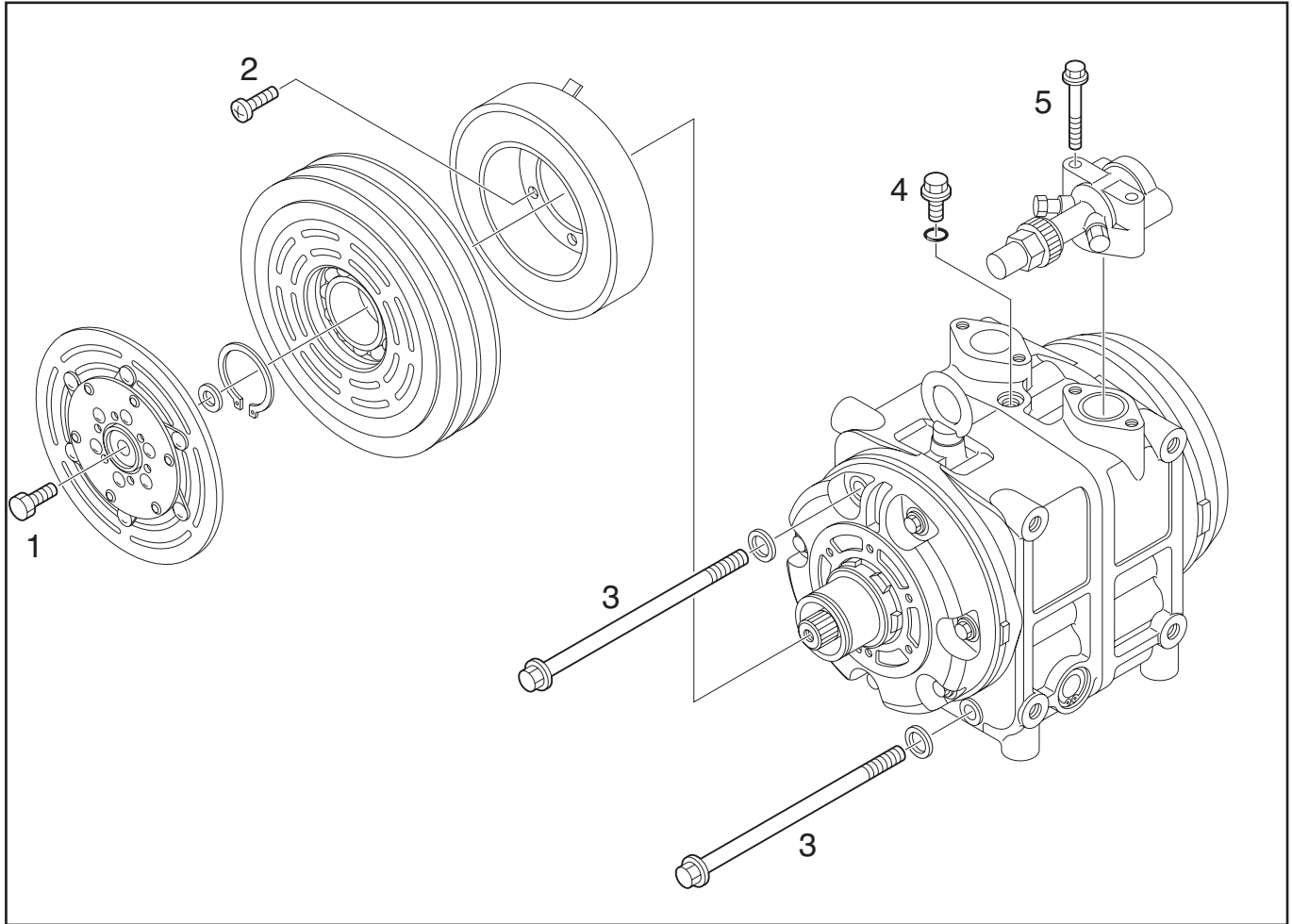

Unit: N.m {kgf.m, ft.lbs}

Part	Thread size	Tightening torque
1. Center bolt	M10 x 1.25	25 - 30 {2.5 - 3.1, 18 - 22}
2. Field coil screw	M6 x 1.0	8 - 12 {0.8 - 1.2, 6 - 9}
3. Bolt	M10 x 1.5	25 - 32 {2.5 - 3.3, 18 - 24}
4. Oil filler plug	M10 x 1.5	15 - 18 {1.5 - 1.8, 11 - 13}
5. Connector bolt	M10 x 1.5	25 - 32 {2.5 - 3.3, 18 - 24}

6- Service procedures - Magnetic clutch

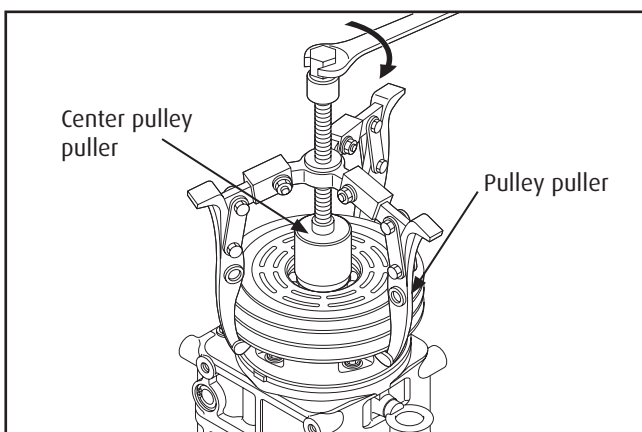
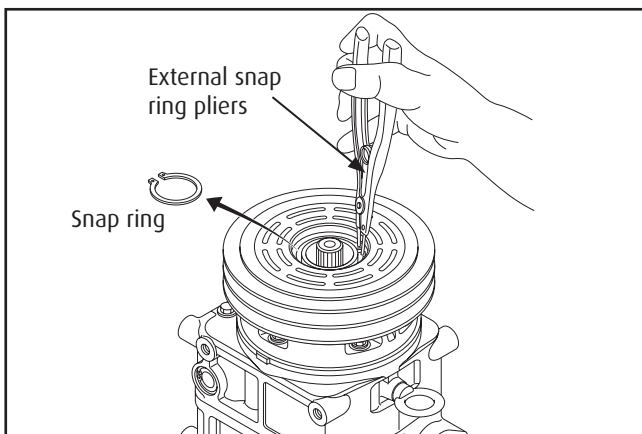
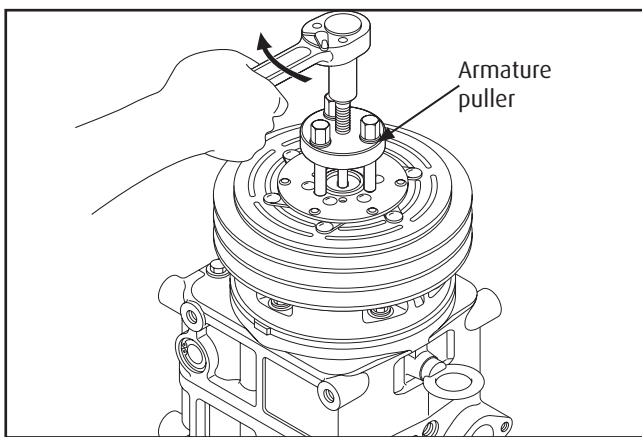
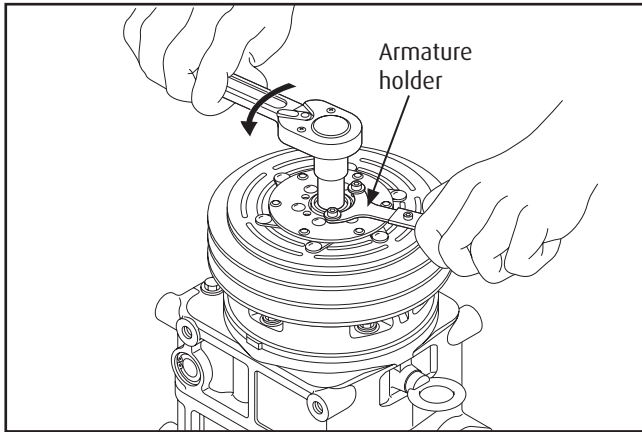

Magnetic clutch

CAUTION!!

This procedure applies to Valeo standard magnetic clutches only. It may differ with other compatible magnetic clutches, please refer to the clutch maker's service procedures.

Removal

1. Remove the armature using an armature puller to prevent armature assembly rotation.
2. Remove the armature assembly using an armature puller. Remove the shims from the compressor drive shaft or armature assembly.
3. Remove the snap ring (Z0010244) using external snap ring pliers.
4. Position the center pulley puller at the end of the driveshaft.
5. Attach a suitable pulley puller to the pulley. Hook the puller claws to the edge of the pulley as shown.
6. Tighten the center pulley puller bolt to remove the pulley.

WARNING!!

Removing the pulley will systematically damage the pulley bearing.

CAUTION!!

Do not clip the puller claws into the pulley groove to prevent pulley groove damage.

6- Service procedures - Magnetic clutch

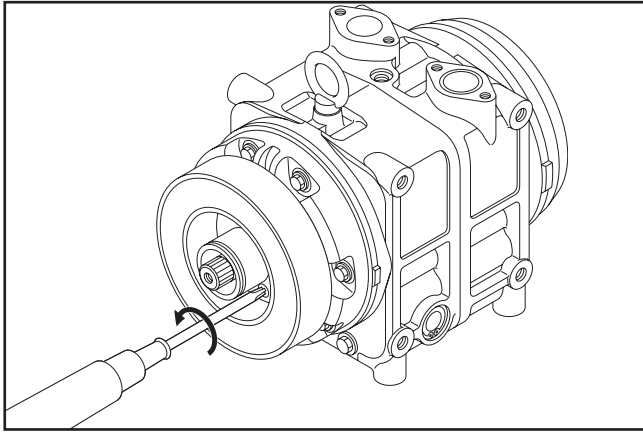

7. Remove the six field coil/compressor screws. Then remove the field coil.

CAUTION!!

Do not hold the field coil by the harness.

Inspection

1. If the contact surface has been damaged by excessive heat, the armature and pulley must be replaced.
2. Check the appearance of the pulley assembly. If the contact surface of the pulley is excessively grooved due to slippage, both the pulley and armature must be replaced. The contact surface of the pulley assembly must be cleaned with a suitable solvent before reinstallation.
3. Check the field coil for a loose connector or cracked insulation.

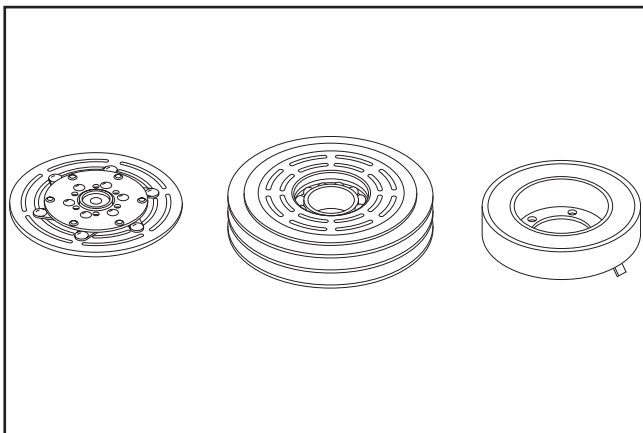

6- Service procedures - Magnetic clutch

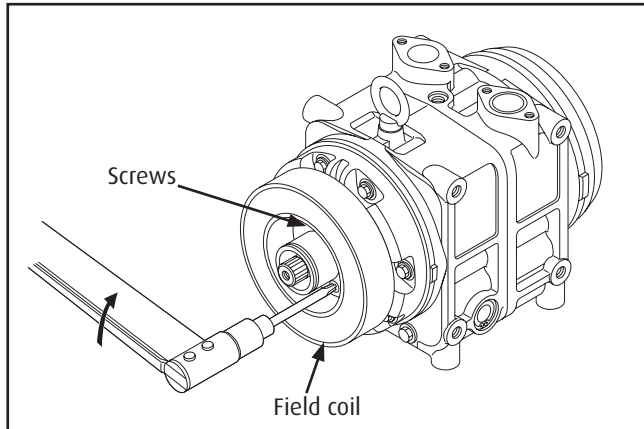

Magnetic clutch

Installation

1. Install the field coil on the compressor (with the harness on top) and tighten the mounting screws to the specified torque.

Specified torque: 8.0 - 12 N.m
{0.8 - 1.2 kgf.m, 6.0 - 9.0 ft. lbs}

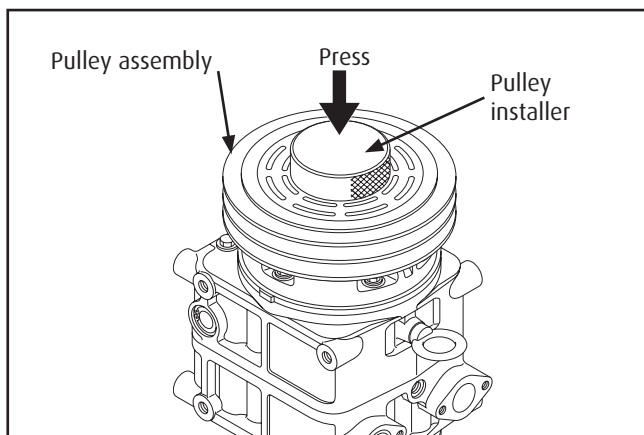

2. Carefully place the wire harness/strain relief.
3. Install the pulley assembly using the pulley installer and a press.

CAUTION!!

Use only a press to install the pulley assembly. Do not use a hammer. The use of a hammer may result in damage or deformation.

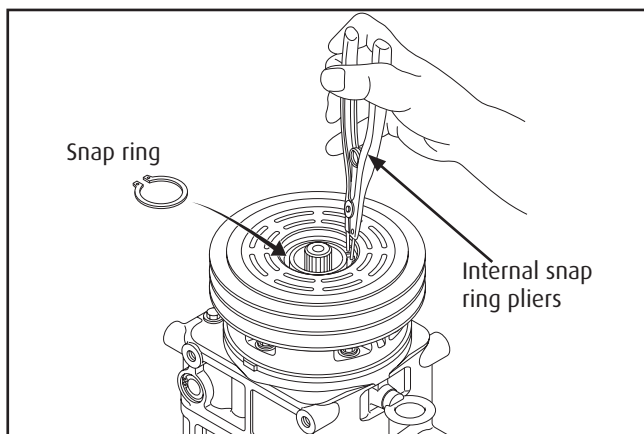

4. Install the snap ring (beveled edge up) using external snap ring pliers.

6- Service procedures - Magnetic clutch

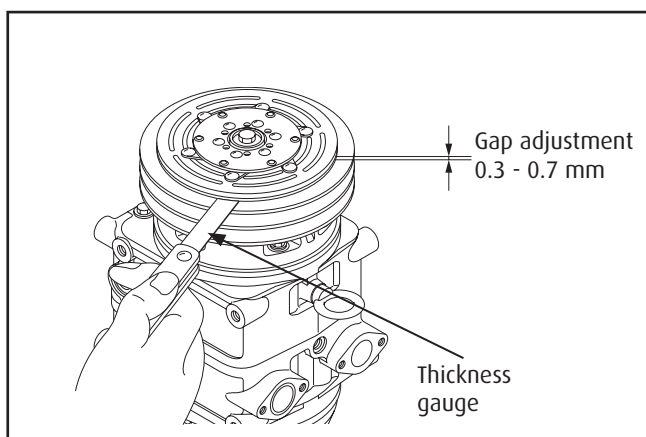
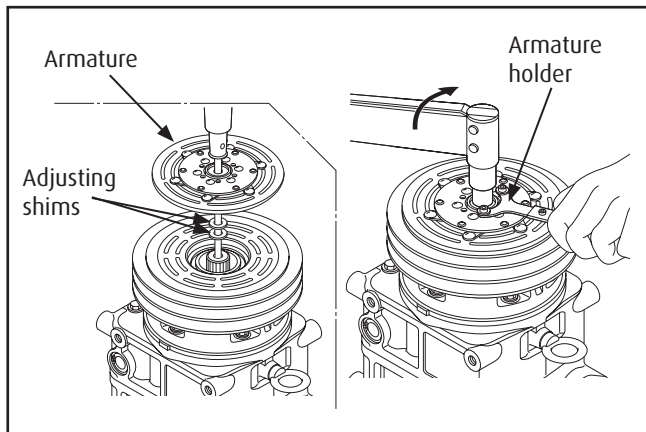

5. Install the armature assembly on the drive shaft together with the original shim(s). Press the armature assembly down by hand.
6. Install the armature bolt and tighten to the specified torque using an armature holder to prevent armature assembly rotation.

Specified torque: 25 - 30 N.m
{2.5 - 3.1 kgf.m, 18 - 22 ft.lbs}

CAUTION!!

After tightening the center bolt, check that the pulley rotates smoothly.

7. Check that the clutch clearance is as specified. If necessary adjust the clearance using shim(s). Adjusting shims are available in the following thicknesses:

Shim Part No.	Thickness
Z0010245	0.2 mm {0.008 in}
Z0010246	0.3 mm {0.012 in}

Specified clearance: 0.3 - 0.7 mm
{0.012 - 0.028 in}

8. Run in the clutch as described on page 21.

7- Service procedures - Shaft seal assembly

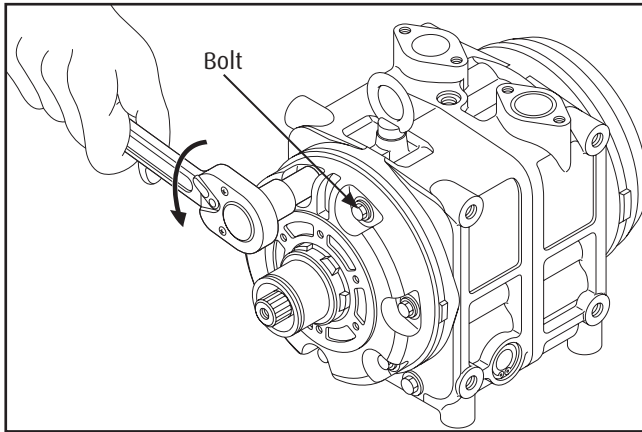

Removal

1. Remove the magnetic clutch assembly as described on page 29.
2. Remove the bolts securing the connectors, and then remove the connectors and strainer from the cylinder shaft assembly.
3. Remove the oil filler plug and then drain the oil.
4. Remove the seven bolts securing the head using an hexagon (14 mm) wrench.
5. Alternately tap the two projections on the front head using a remover and a mallet to remove the front cylinder head.

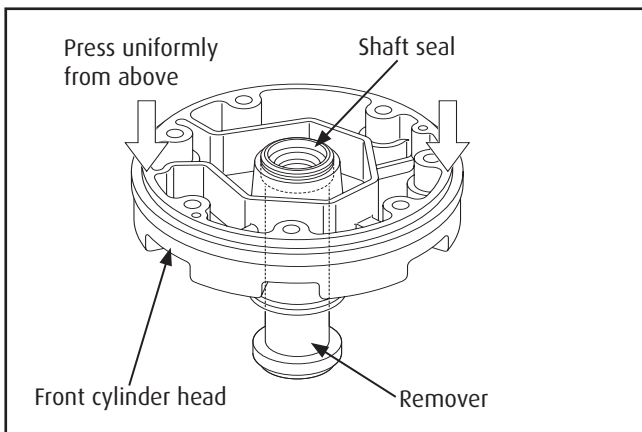
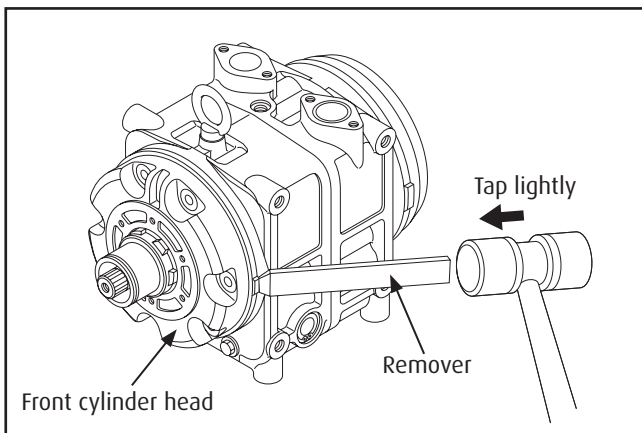

6. Remove the shaft seal assembly using a remover.

7- Service procedures - Shaft seal assembly

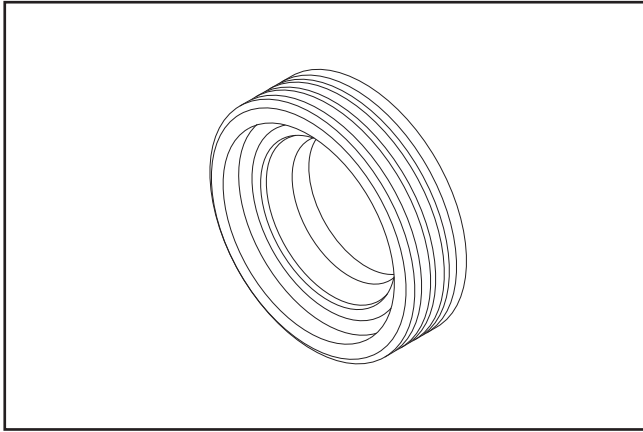

Inspection

The shaft seal must not be reused.

Always use a new shaft seal when reassembling the compressor. Ensure that the seal seat is free from lint and dirt that could damage the shaft seal lip.

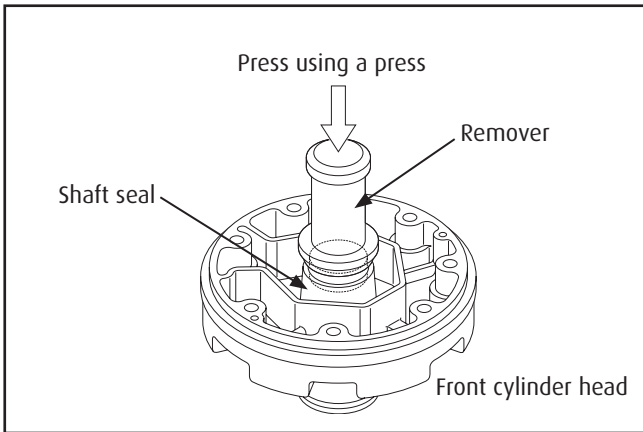

Installation

1. Clean the portion of the front cylinder head where the shaft seal is to be assembled.
2. Assemble the shaft seal on the remover.
3. Coat the shaft seal well with compressor oil and install the shaft seal in the front cylinder head.
4. Remove the shaft seal remover.

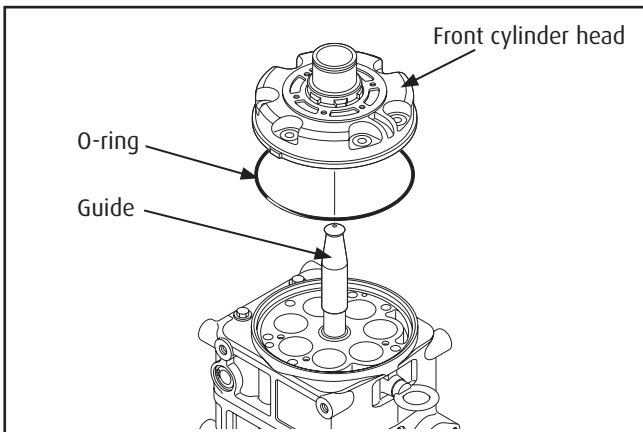

5. Position the guide on the shaft
6. Coat the new O-ring with clean compressor oil and install it in the front cylinder head
7. Install the front cylinder head

CAUTION!!

Align the pins and tap the head lightly and evenly with a plastic hammer.

8. Remove the guide
9. Install the seven bolts from the front cylinder head side and tighten them to the specified torque:

**Specified torque: 25 - 32 N.m
{2.5 - 3.3 kgf.m, 18 - 24 ft.lbs}**

Tighten each bolt gradually (in three or more stages) to ensure the specified torque.

10. Turn the drive shaft 2, 3 times by hand to ensure that the shaft rotates smoothly.

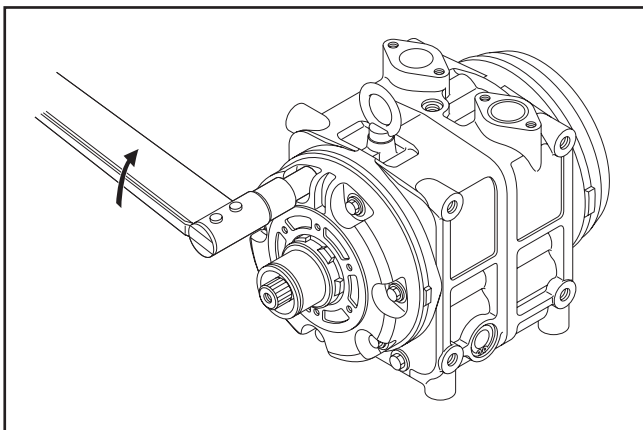

7- Service procedures - Shaft seal assembly

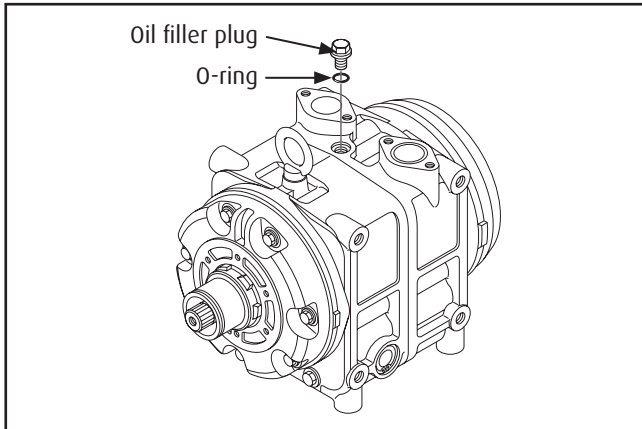

11. Fill the compressor with the specified amount of clean compressor oil through the oil filler.

12. Install the oil filler plug with a new O-ring, and tighten it to the specified torque:

Specified torque: 15 - 18 N.m
{1.5 - 1.8 kgf.m, 11 - 13 ft.lbs}

13. Install the strainer in the suction port.

14. Fit the blanking plates/connectors to the suction and discharge connections, and tighten them to the specified torque:

Specified torque: 25 - 32 N.m
{2.5 - 3.3 kgf.m, 18 - 24 ft.lbs}

15. Install the magnetic clutch as described on page 31.

16. Run in the compressor as described on page 21.

17. Perform the leak test as described on page 22.

8- Service procedures - Cylinder heads

Cylinder heads (Front & Rear)

Disassembly

1. Remove the magnetic clutch assembly as described on page 29.
2. Remove the four bolts securing the connectors, and then remove the connectors and strainer from the cylinder shaft assembly.
3. Remove the oil filler plug and then drain the oil.
4. Remove the seven bolts securing the heads.
5. Alternately tap the two projections on the front head using the remover and mallet to remove the front cylinder head.
6. Remove the front valve plate assembly and then the suction valve (in that order).
7. Remove and discard the O-ring from the front cylinder head.
8. Remove all gasket material from the front cylinder head and the front valve plate.

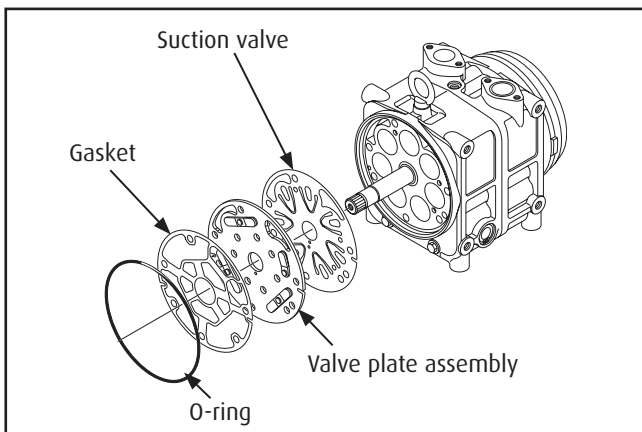
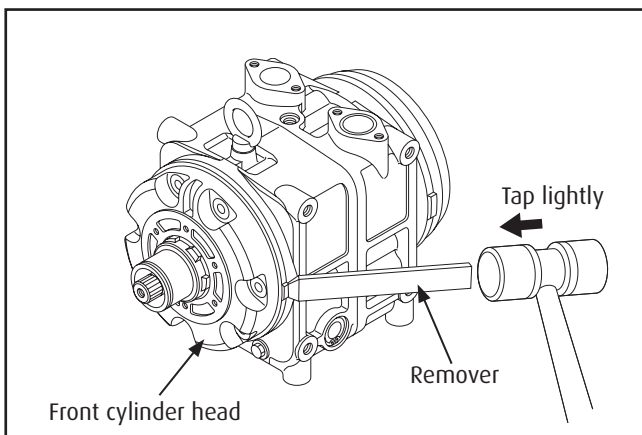
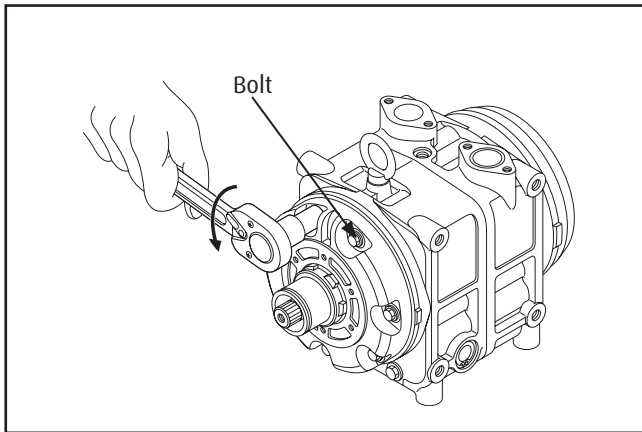

8- Service procedures - Cylinder heads

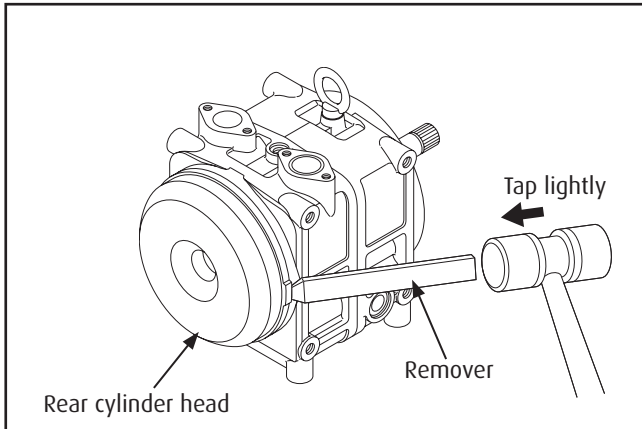

9. Alternately tap the two projections on the rear head using the remover and mallet to remove the rear cylinder head.

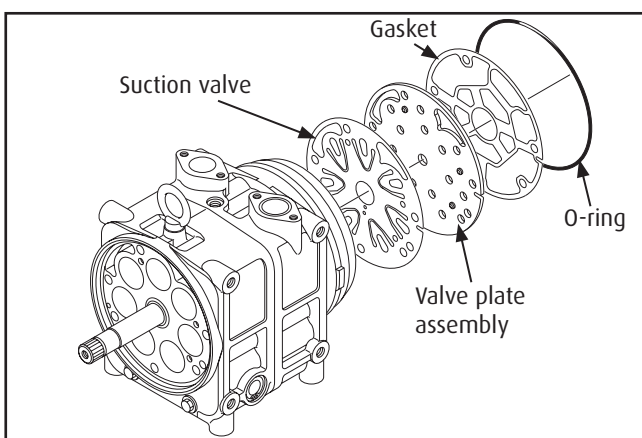

10. Remove the rear valve plate assembly and then the suction valve (in that order).

11. Remove and discard the O-ring from the rear cylinder head.

12. Remove all gasket material from the rear cylinder head and the rear valve plate.

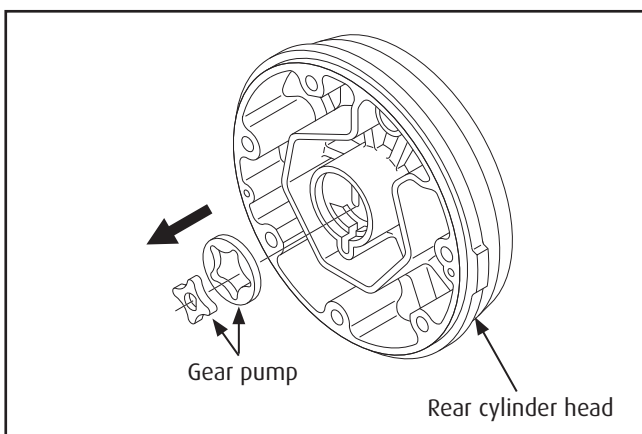

13. Remove the gear pump from the rear cylinder head or the end of the driveshaft.

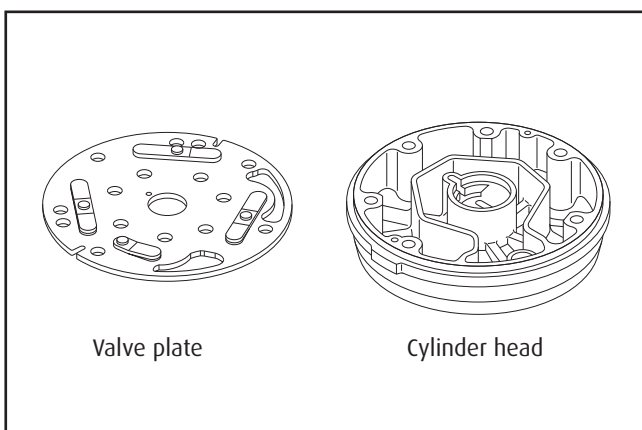

Inspection

Check the front and rear valve plates for scratched, bent or damaged parts.

Inspect both cylinder heads and both valves plates for nicks or burrs on the sealing surfaces.

Clean both cylinder heads and both valve plates or replace them if they are cracked or damaged.

Check that there are no clogged passages in the valve plates.

8- Service procedures - Cylinder heads

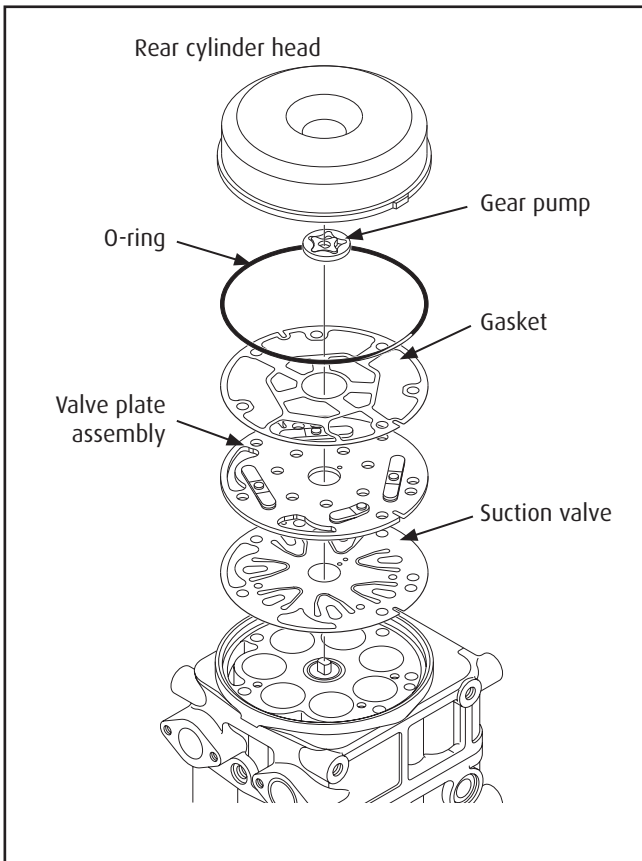
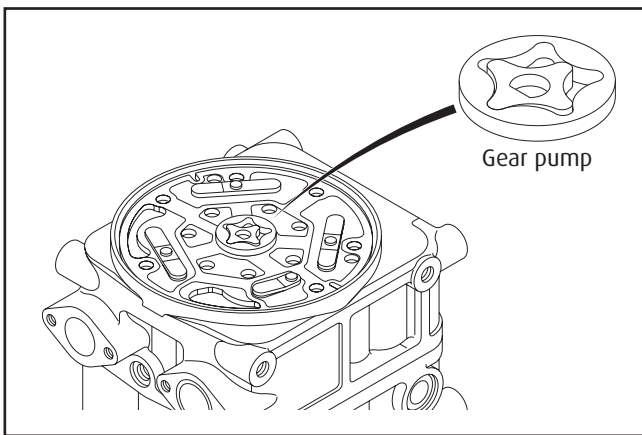
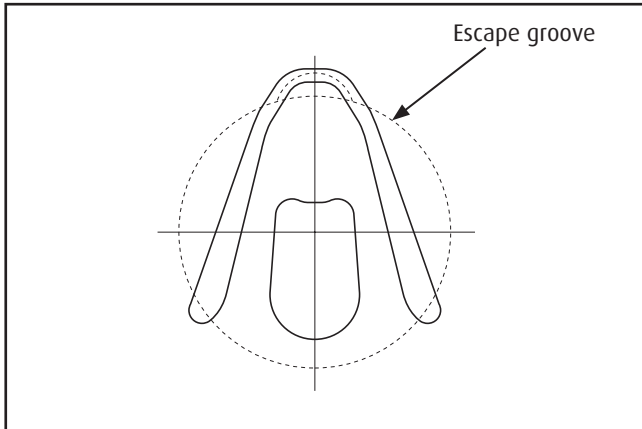

Reassembly

Rear cylinder head

1. Place the cylinder shaft assembly on the bench with the rear side up.
2. Install the rear suction valve so that it matches the pins.

CAUTION!!

Ensure each valve matches each cylinder valve escape groove.

3. Install the rear valve plate on the rear suction valve.

CAUTION!!

Do not mistake the front and rear valve plates.

4. Coat the new gasket with clean compressor oil and install it on the rear valve plate.
5. Coat the new gear pump with clean compressor oil and install it on the end of the drive shaft.

6. Coat the new O-ring with clean compressor oil and install it on the rear cylinder head.
7. Install the rear cylinder head.

When positioning the head, ensure the gear pump is inserted into the hole in the cylinder head.

8- Service procedures - Cylinder heads

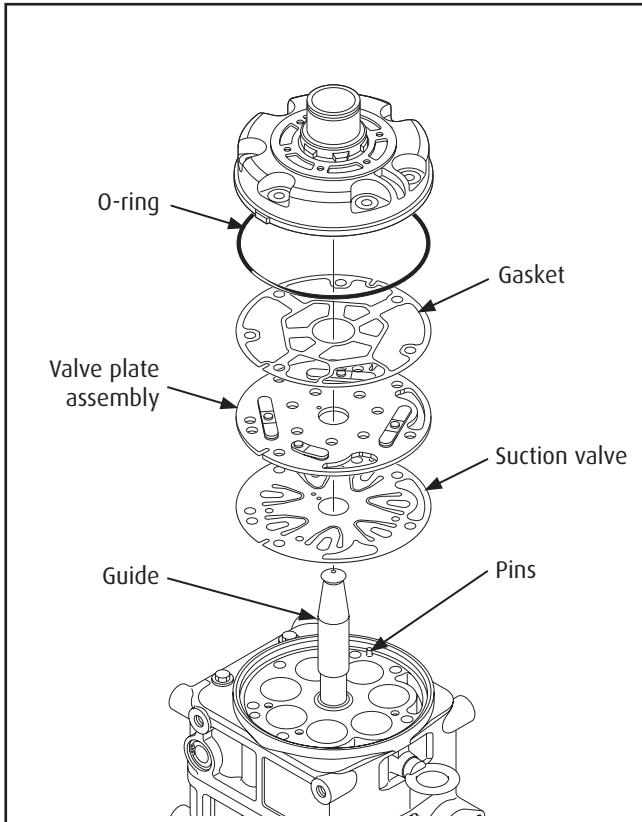

Front Cylinder Head

1. Place the cylinder shaft assembly on the bench with the front side up.
2. Install the front suction valve so that it matches the spring pins.

CAUTION!!

Ensure each valve matches each cylinder valve escape groove.

3. Install the front valve plate on the front suction valve.
4. Coat the new gasket with clean compressor oil and install it on the front valve plate.
5. Position the guide on the shaft.
6. Coat the new O-ring with clean compressor oil and install it on the front cylinder head.
7. Install the front cylinder head.

CAUTION!!

Align the spring pins and tap the head lightly and evenly with a plastic hammer.

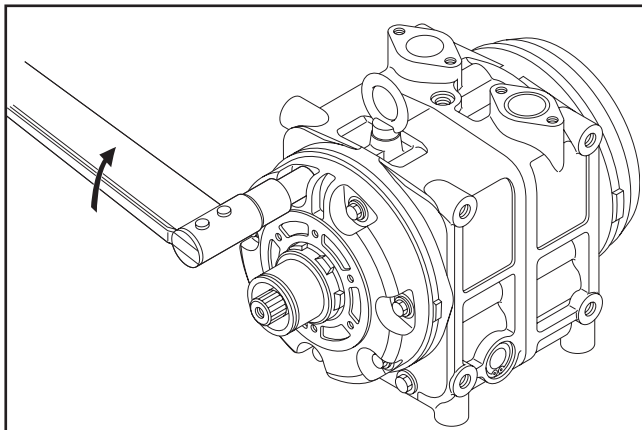

8. Remove the guide.
9. Install the seven bolts from the front cylinder head side and tighten them to the specified torque.

Specified torque: 25 ~ 32 N.m
{2.5 - 3.3 kgf.m, 18 - 24 ft.lbs}

Tighten each bolt gradually (in three or more stages) to ensure the specified torque.

10. Turn the drive shaft 2, 3 times by hand to ensure that the shaft rotates smoothly.
11. Fill the compressor with the specified amount of clean compressor oil through the oil filler.
12. Install the oil filler plug with a new O-ring and tighten it to the specified torque.

Specified torque: 15 - 18 N.m
{1.5 - 1.8 kgf.m, 11 - 13 ft.lbs}

13. Install the strainer in the suction port.
14. Fit blanking plates/connectors to the suction and discharge connections, and tighten it to the specified torque.

Specified torque: 25 - 32 N.m
{2.5 - 3.3 kgf.m, 18 - 24 ft.lbs}

15. Install the magnetic clutch (see p.31).
16. Run in the compressor (see p.21).
17. Perform the leak test (see p.22).

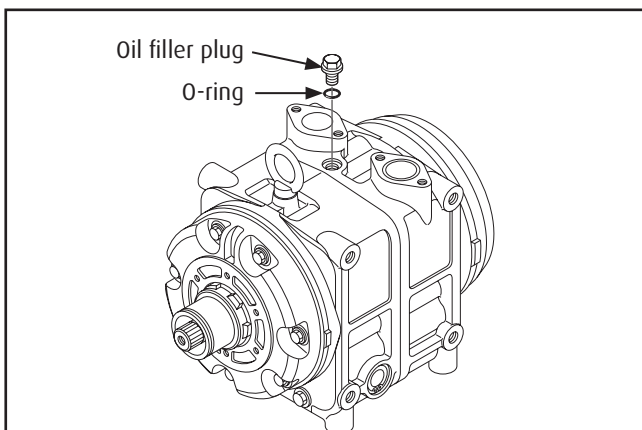

9- Service tools

In addition to standard tools, numerous special tools are necessary to service the Valeo **TM-55 & TM-65** compressors. The use of these special tools enables prompt and correct compressor service.

The drawings and the specifications of the service tools listed below are enclosed in the following pages.

Service tools

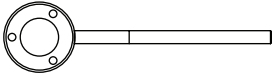
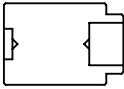
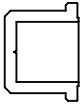
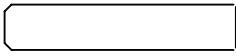
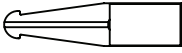
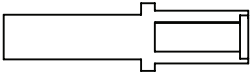
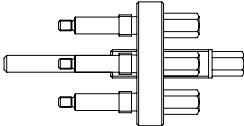
Item	Name	Picture	Ref. page	Application	Drawing page
1	Armature holder		29, 32	To fix armature	41
2	Center pulley puller		29	To remove pulley	41
3	Pulley installer		31	To install pulley	42
4	Cylinder head remover		33, 36, 37	To remove cylinder head and cylinder block	42
5	Guide		34, 39	To install shaft seal	43
6	Shaft seal remover / installer		33, 34	To remove and insert the shaft seal	43
7	Armature puller assy		29	To remove armature	44-45

9- Service tools

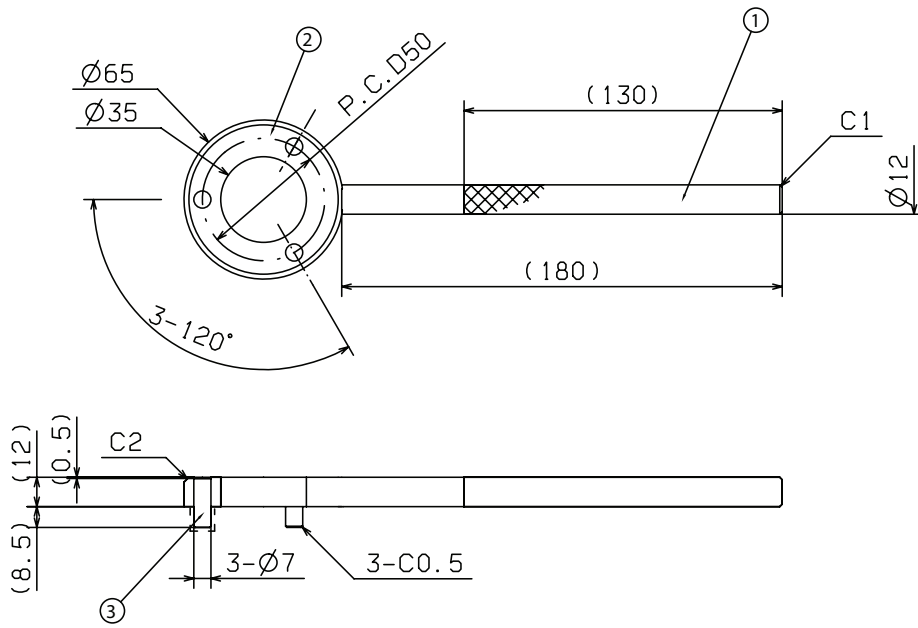

Unless otherwise specified,
the edges to be slight chamfering.
Should remove burrs and fluff.

3rd Angle Proj. 	Surface Treatment	Br		
	Heat Treatment & Hardness	- -HOF - HTL HRC40 to 45		
	Material	① SS41	② SS41	③ S45C

Part Name

Armature Holder

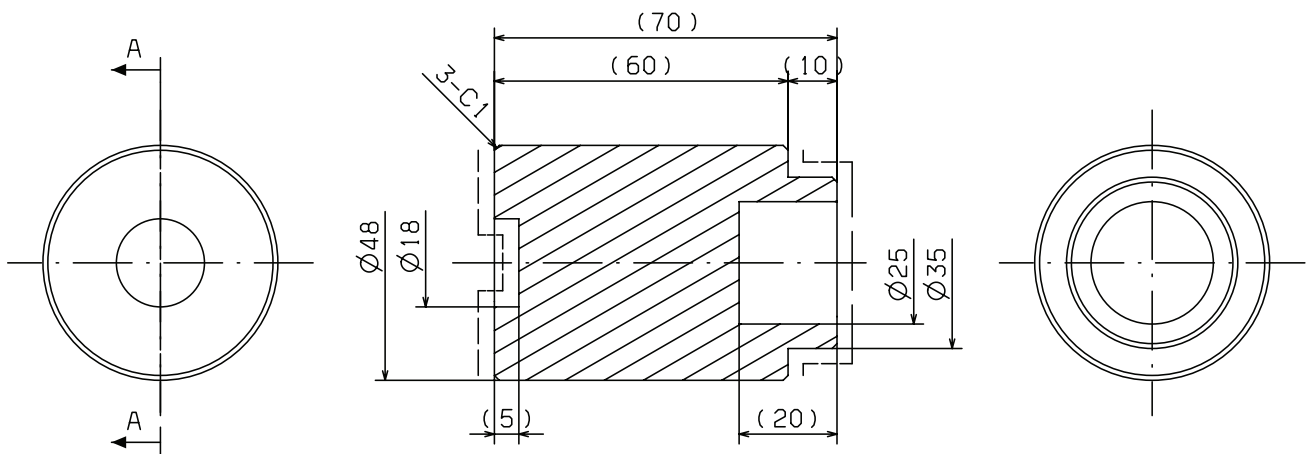

Section view A-A

Unless otherwise specified,
the edges to be slight chamfering.
Should remove burrs and fluff.

3rd Angle Proj. 	Surface Treatment			
	Heat Treatment & Hardness	- -HQ - HTL HRC40 to 45		
	Material	S45C		

Part Name

Center Pulley Puller

9- Service tools

Section view A-A

Unless otherwise specified, the edges to be slight chamfering. Should remove burrs and fluff.

3rd Angle Proj.	Surface Treatment	
	Heat Treatment & Hardness	HQ - HTL HRC58
	Material	SK105 (JIS)
Part Name Pulley Installer		

Remover (for cyl. head)

Unless otherwise specified, the edges to be slight chamfering. Should remove burrs and fluff.

3rd Angle Proj.	Surface Treatment	
	Heat Treatment & Hardness	
	Material	SK85 (JIS)
Part Name Remover (for cyl. head)		

9- Service tools

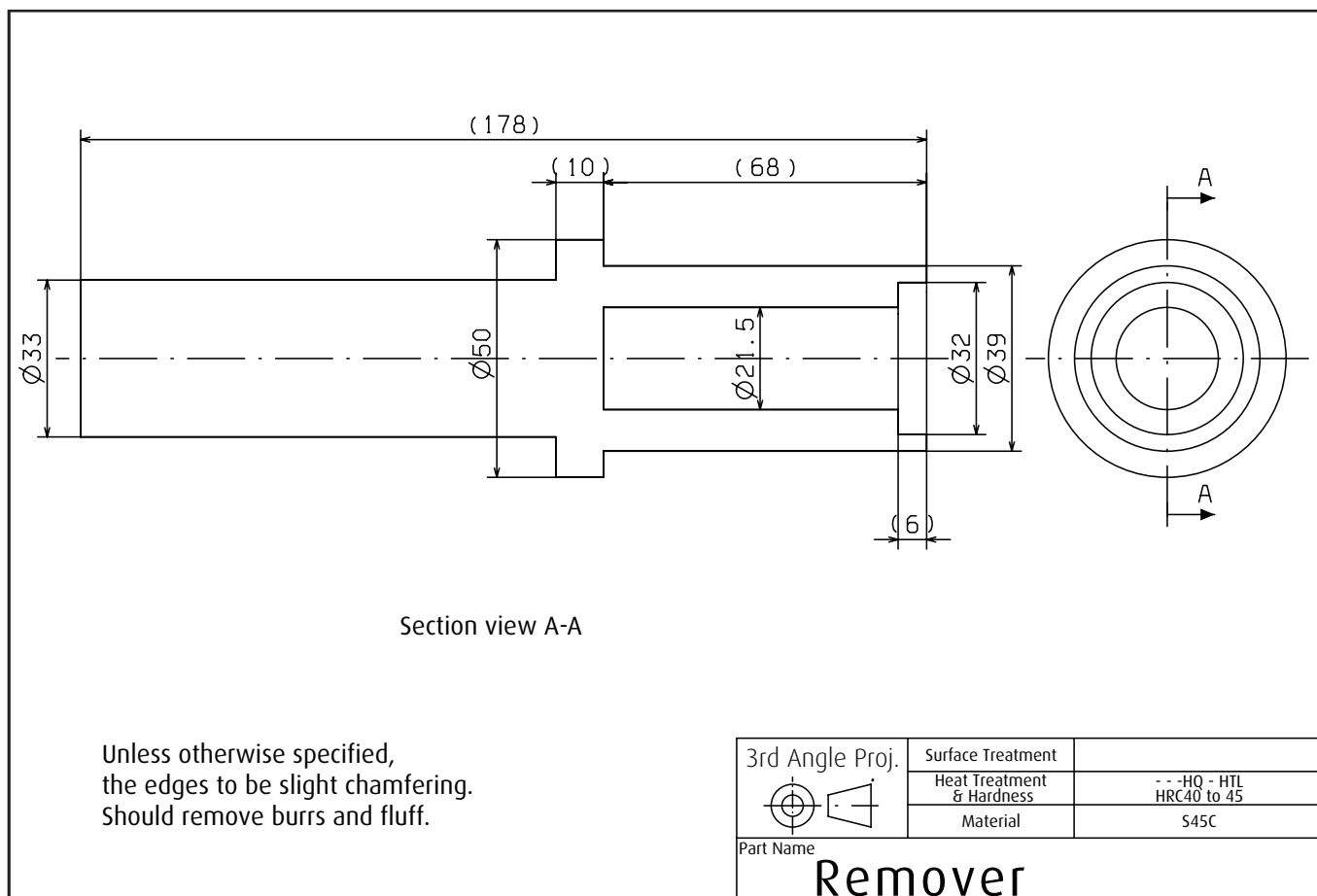
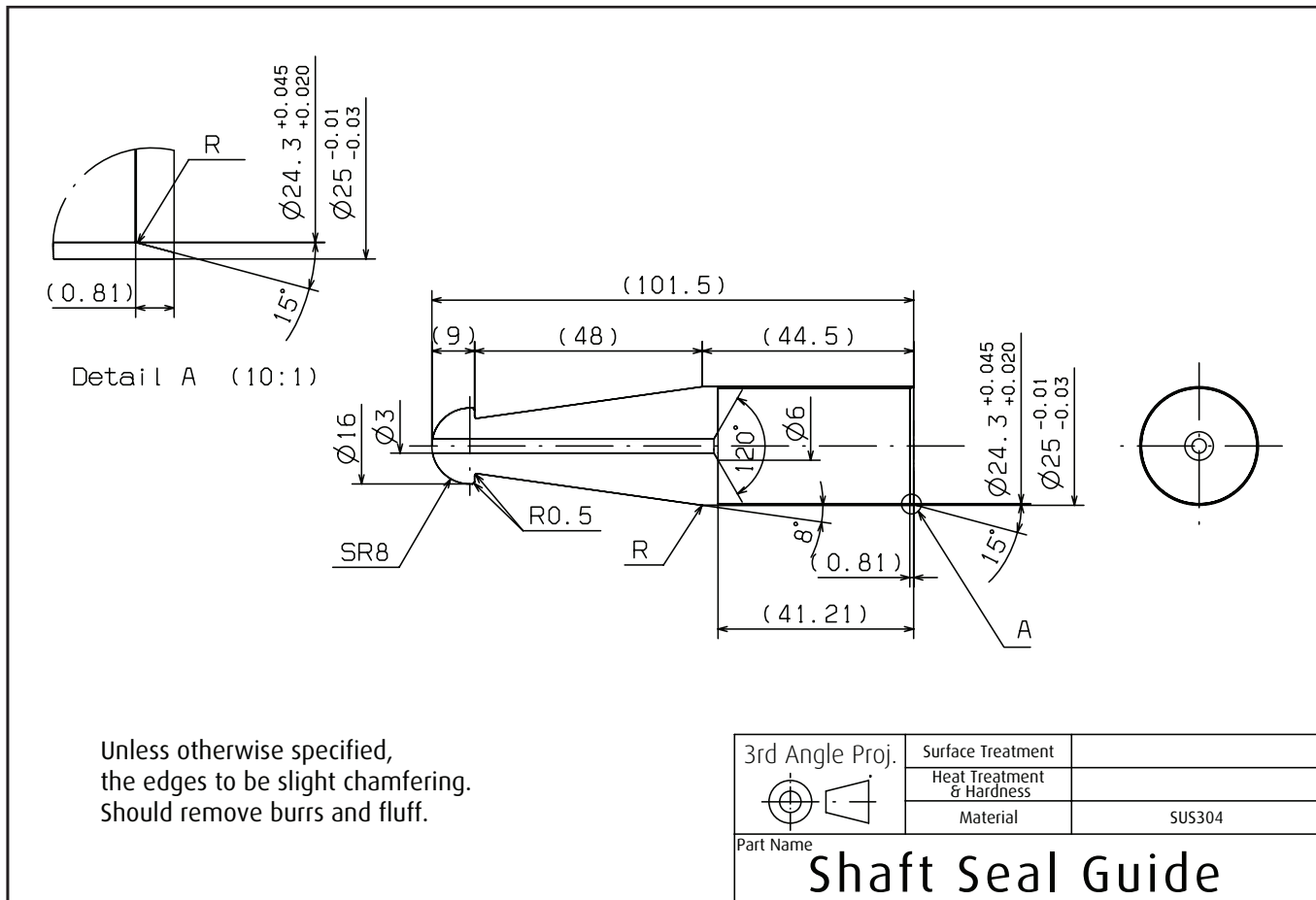

9- Service tools

①	Plate
②	Pole
③	Bolt

3rd Angle Proj. 	Surface Treatment	
	Heat Treatment & Hardness	
	Material	
Part Name		
Armature Puller Assy		

Armature puller assy	①
----------------------	---

Unless otherwise specified,
the edges to be slight chamfering.
Should remove burrs and fluff.

3rd Angle Proj. 	Surface Treatment	Br
	Heat Treatment & Hardness	
	Material	S45C
Part Name		
Plate		

9- Service tools

Armature puller assy (2)

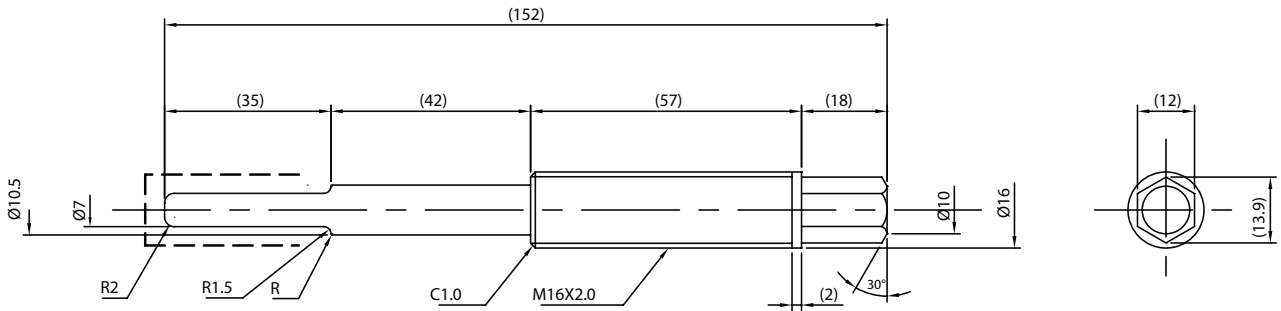

Unless otherwise specified,
the edges to be slight chamfering.
Should remove burrs and fluff.

3rd Angle Proj. 	Surface Treatment	Br
	Heat Treatment & Hardness	- HQ - HQ1 HRC40 to 45
	Material	S45C
Part Name		Pole

Armature puller assy (3)

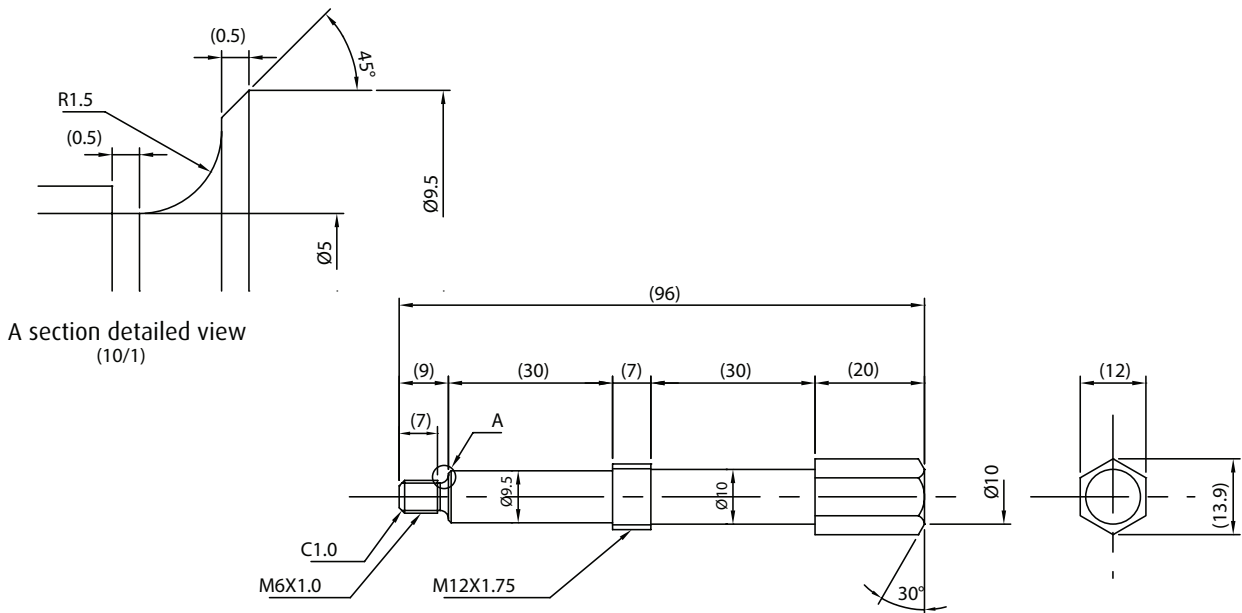

A section detailed view
(10/1)

Unless otherwise specified,
the edges to be slight chamfering.
Should remove burrs and fluff.

3rd Angle Proj. 	Surface Treatment	Br
	Heat Treatment & Hardness	
	Material	S45C
Part Name		Bolt

10- Service parts

1. Compressor body service kits, sets and parts

Item*	Part name	Reference	Quantity
OVERHAUL KIT (O-RING SET + GASKET SET + SHAFT SEAL)		Z0014427	-
O-RING SET		Z0014430	-
12	O-ring body (front & rear head)	Z0004833	n=2
20	O-ring drain	569300-4000	n=1
GASKET SET		Z0014431	-
13	Gasket front head	Z0004779	n=1
31	Gasket rear head	Z0004780	n=1
9	Gasket (bolt) 9 per set	569310-6200	n=9
SHAFT SEAL (for service)		-	-
11	Shaft seal	Z0007461	n=1
OTHER COMPRESSOR PARTS		-	-
14	Valve plate assy (front)	Z0004775	n=1
30	Valve plate assy (rear)	Z0004777	n=1
15	Suction valve	Z0004774	n=1

*See Product description - Exploded view (p.10)

2. Connector assy (Z0011222) service parts

Item*	Part name	Reference	Quantity	Remarks
24	Connector (body)	Z0011223	n=1	Dis./Suc.
23	Gasket	Z0011226	n=1	For conn.
26	Gasket	Z0011227	n=1	For piping
25	Bolt	Z0011228	n=2	For conn.

*See Product description - Exploded view (p.10)

3. Oil

Item	Part name	Reference	Quantity
-	ZXL 100PG (250 cc)	569900-0600	250 cc

VALEO COMPRESSORS - **TM-55 & TM-65** for HFC-134a use
SERVICE MANUAL

Printing: April 2010

Published by: VALEO THERMAL SYSTEMS JAPAN CO, LTD.

Printed in Japan

Copyright 2010, VALEO THERMAL SYSTEMS JAPAN CO, LTD.

For any inquiry regarding the present service manual,
contact us at vc-oura-sales@valeo.com

Valeo **TM-55** & **TM-65** Compressors for Bus Air-Conditioning

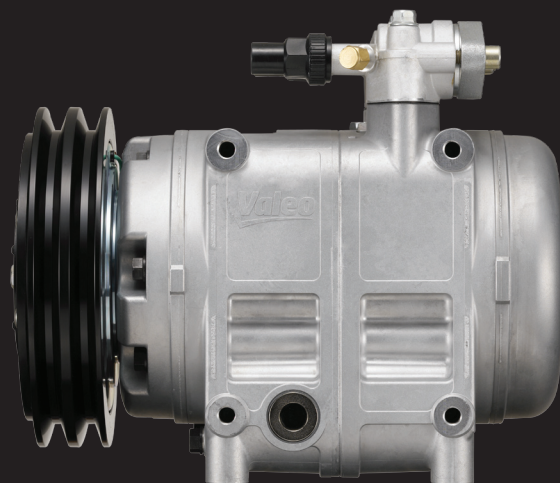

Valeo **TM-55** & **TM-65** Benefits

- High reliability
- Integration flexibility
- Great cooling capacity
- Enhanced performance
- Lower fuel consumption
- Compact & robust design
- Improved field serviceability
- Reduced noise and vibrations
- Staggering value through innovation

valeo added 

www.valeocompressors.com

EE28E-13010

Asia

39 Sendai, Kumagaya-shi
Saitama-ken 360-0193 Japan
Phone: +81 (0) 48 539 3800
Fax: +81 (0) 48 539 3843
Email: vc-oura-sales@valeo.com

China

No.2677 Shiji Avenue, Eco. & Tec. Dvt
Zone 130031 Changchun, Jilin PRC
Phone: +86 (0) 431 8499 2025
Fax: +86 (0) 431 8499 2004
Email: vc-changchun-sales@valeo.com

Europe & Middle East Africa

6, rue Francois Cevert
BP71014 49015 Angers, France
Phone: +33 (0) 241686 234
Fax: +33 (0) 241 686 239
Email: vc-angers-sales@valeo.com

Americas

2520 Esters Blvd #100
Dallas, TX 75261 United States
Phone: +1 972 456 1077
Fax: +1 972 456 1090
Email: vc-dallas-sales@valeo.com