

Bill of Materials Listing

TransArctic Canada Inc.

3/31/2008
Page 1 of 1

Product Number	Description	Date	Weight	Uof M	Yield
Line Component Prod#	Description	Bin Unit	Qty		
KMN84521	Mt. Kit, MForce DT, FE300, 2 TM-21,07		08/30/04	15.85	0
10	BMN80034		Bkt, Comp, Upper, CE200	each	1
20	BMN80035		Bkt, Comp, Lower, CE300	each	1
30	BMN80049		Bkt, Idler, Weldment, FE300	each	1
31	BMN80038		Bkt, Rad Hose, PMax DT, CE300	each	1
50	PUL80074		Pulley, Idler, B/S, Wide, 76d (89102)	each	2
52	BEL02743		Belt, 10gr, 2743mm (108")	each	1
60	KBN84521		Bag Kit, Fasteners, KMN84521	each	1
61	BMS16022		Bkt, TM-16 Spacer Plate	each	4
62	SCD14010		Spacer, Col, Drl, 14mm x25.4o x10.32i	each	1
72	CLP20040		Clamp, "P" type, #40, 1/2"w, 2 1/2", PC	each	1
82	CLP36001		Clamp, Gear, #36,1 13/16-2 3/4 (46/70mm)	each	2

Bill of Materials Listing

TransArctic Canada Inc.

3/31/2008
Page 1 of 1

Product Number	Description	Date	Weight	Uof M	Yield
Line Component Prod#	Description	Bin Unit	Qty		
KBN84521	Bag Kit, Fasteners, KMN84521		05/03/07	1.56	0
10	BTC08100		Bolt, Hex, 8 x 1.25 x 100mm, 10.9, Plt	each	4
20	BTC08140		Bolt, Hex, 8 x 1.25 x 140mm, 10.9, Plt	each	4
21	BTC08110		Bolt, Hex, 8 x 1.25 x 110mm, 10.9, Plt	each	4
30	BTC10040		Bolt, Hex, 10 x 1.5 x 40mm, 10.9, Plt	each	1
40	CSF10046		Capscrew, FH, 10 x 1.5 x 45mm, 10.9,Plt	each	1
50	WFA08000		Washer, Flat, 8mm, 8.8, Plt	each	8
60	WLA08000		Washer, Lock, 8mm, 8.8, Plt	each	9
63	NTA08000		Nut, Hex, 8 x 1.25, 8.8, Plt	each	1
70	WFA10000		Washer, Flat, 10mm, 8.8, Plt	each	1
80	WLA10000		Washer, Lock, 10mm, 8.8, Plt	each	1
90	BTS10001		Bolt, Shoulder, 10mm (89064)	each	2
100	WDS17001		Washer, Dust Cover (89060)	each	2
130	BTP04075		Bolt, Hex, 1/4-20unc, .75", 5, Plt	each	1
140	NTP04000		Nut, Hex, 1/4-20unc, 5, Plt	each	1
150	WFS04003		Washer, Flat, 1/4", 2, USS, Plt	each	1

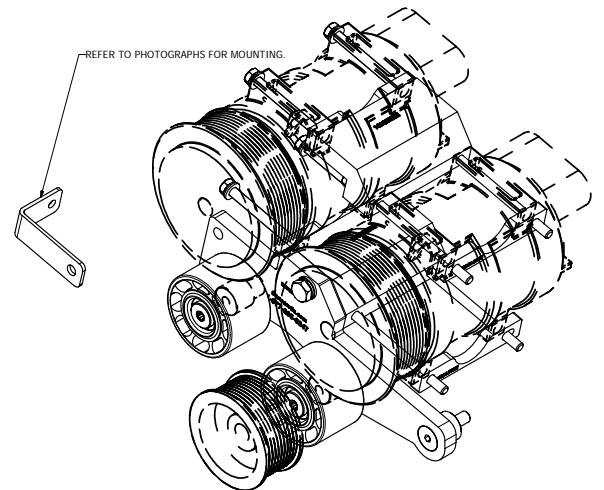
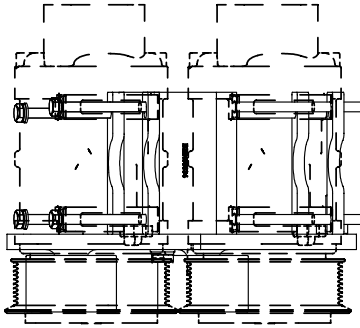

ISOMETRIC VIEW



USE 2 x BMS16022 SPACER PLATE AND 4 x BTC08110 BOLTS WHEN INSTALLING TM-16'S.

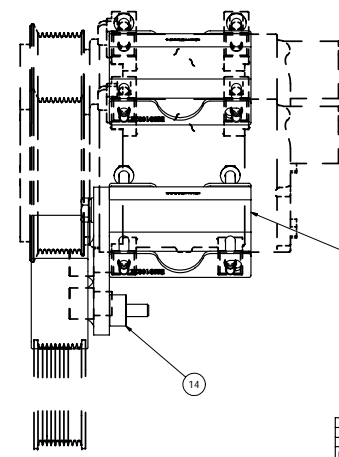
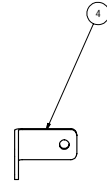
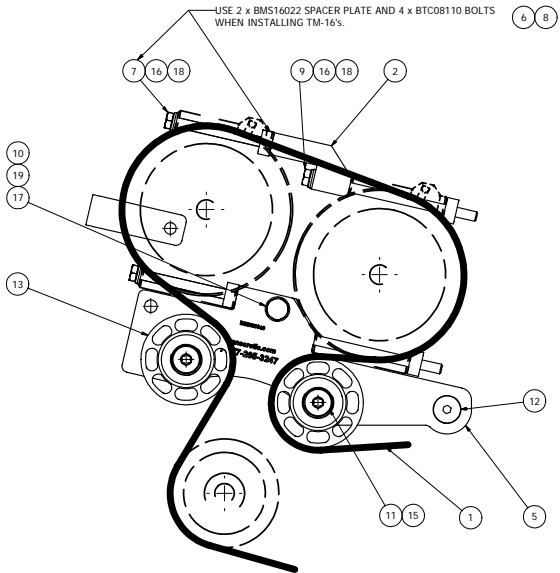

- NOTES:
- 1) USE SERVICABLE THREADLOCKER ON ALL FASTENERS TO ENGINE COMPONENTS AND TORQUE ALL BOLTS TO S.A.E. SPECIFICATIONS.
 - 2) SEE "TRANSARCTIC A/C COMPRESSOR MOUNT INSTALLATION DISCLAIMER".
 - 3) MODIFY EXISTING RADIATOR HOSE ON PASSENGER SIDE (TO CLEAR BELT.) BY REMOVING HOSE AND FLIPPING END FOR END AND THEN RE-INSTALL ON THE ENGINE. (USING NEW BRKT SUPPLIED.)

ITEM	QTY	U/M	PART NUMBER	DESCRIPTION
19	1	EACH	WLA10000	WASHER, LOCK, 10mm, 8.8, PLT
18	8	EACH	WLA8000	WASHER, LOCK, 8mm, 8.8, PLT
17	1	EACH	WFA10000	WASHER, FLAT, 10mm, 8.8, PLT
16	8	EACH	WFA8000	WASHER, FLAT, 8mm, 8.8, PLT
15	2	EACH	WDS17001	WASHER, DUST COVER (PUL80076)
14	1	EACH	SCD14010	SPACER, COL, DRL, 14mm x 25.4o x 10.32i
13	2	EACH	PUL80074	PULLEY, IDLER, BACKSIDE, PB, 74D, 46.27W
12	1	EACH	CSF10046	CAPSCREW, FH, 10 x 1.5 x 45mm, 10.9, PLT
11	2	EACH	BTS10001	BOLT, SHOULDER, 10mm (IDLER PULLEY)
10	1	EACH	BTC10040	BOLT, HEX, 8 x 1.5 x 40mm, 10.9, PLT
9	4	EACH	BTC08140	BOLT, HEX, 8 x 1.25 x 140mm, 10.9, PLT
8	4	EACH	BTC08110	BOLT, HEX, 8 x 1.25 x 110mm, 10.9, PLT
7	4	EACH	BTC08100	BOLT, HEX, 8 x 1.25 x 100mm, 10.9, PLT
6	4	EACH	BMS16022	BKT, TM-16, SPACER PLATE
5	1	EACH	BMN80049	BKT, IDLER, WELDMNT, FE300
4	1	EACH	BMN80038	BKT, RAD HOSE, PMAX DT, CE300
3	1	EACH	BMN80035	BKT, COMP, LOWER, CE300
2	1	EACH	BMN80034	BKT, COMP, UPPER, CE300
1	1	EACH	BEL02743	BELT, 10gr, 2743mm (108")

BILL OF MATERIALS

DRAWN	James Stewart	03/28/08	TRANSARCTIC INC.
CHECKED	James Stewart	03/28/08	
RELEASED TO PRODUCTION	03/31/08	VAL: CA	TITLE
REVISION	DESCRIPTION	DATE	BY
1	THIS DRAWING CONTAINS PROPRIETARY CONFIDENTIAL INFORMATION OWNED BY TRANSARCTIC CANADA INC. THE DOCUMENT AND THE INFORMATION IT IS NOT TO BE USED, DISCLOSED OR REPRODUCED WITHOUT EXPRESS WRITTEN PERMISSION OF THE COMPANY.	03/28/08	James Stewart
2		03/28/08	Ron Ingram
3		03/28/08	Dale Mason

MT. KIT, MFORCE DT, FE300, 2
TM-21/16.07

UNSPECIFIED TOLERANCES: DIM (MM) ±.005
DIM (INCH) ±.0005
ANGULAR ±.01

THIRD ANGLE PROJECTION

DRAWING UNIT OF MEASURE: MM (INCH)

SCALE: 1:2

REV 0

SHEET 1 OF 1

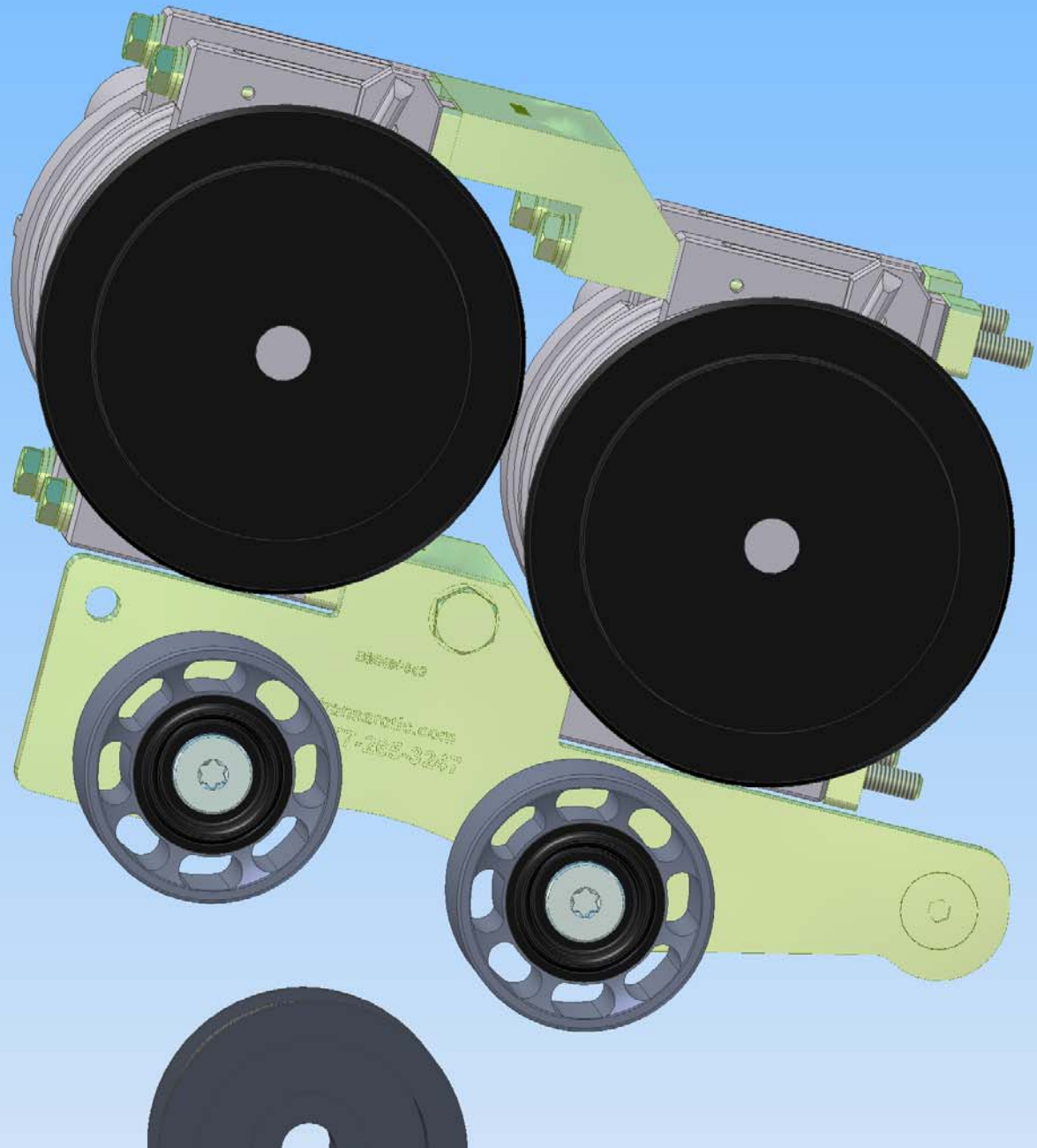

KMN84520 - Mt. Kit, MForce DT, FE300, 2 TM-21/TM-16



Rad hose is reversed and hose is supported from Rad shroud.

TransArctic A/C Compressor Mount Installation Disclaimer

All compressor mounts should be installed by qualified and trained personnel using proper tools and equipment in safe working conditions following industry standard guidelines for motor vehicle service and repair.

The installer of any compressor mount purchased from TransArctic must undertake all responsibility of issues arising from that compressor bracket being installed on any vehicle. As well as insure that a **proper and sufficient ground** is established between the compressors' clutches and the vehicle's engine. Mount functionality, operation and durability can all be compromised by an incompetent installation.

Due to the many different situations, parameters and application criteria, which are beyond the compressor mount manufacturer's control, TransArctic does not warrant design, durability, or operational functionality of any compressor mount improperly installed by another party.

With no implied guarantees it is the mount installer's strict responsibility to determine safety and functionality, of the compressor mount, at the time of installation.

Please contact TransArctic with any issue arising from installation so we may better improve the product. If you have any reservations about the compressor mount integrity contact TransArctic immediately at 1-877-COLD-AIR.