

Bill of Materials Listing

TransArctic Canada Inc.

7/19/2007

Page 1 of 1

Product Number		Description	Bin	Date	Weight	Uof M	Yield
Line	Component Prod#	Description		Unit	Qty		
KMC62651		Mt Kit, ISB, 6.7L, BBFE, 2 TM-21, '07		7/6/2007		27.64	0
10	BEL11168	Belt, A gr, 1168mm (46") (17460)		each	1		
20	BMC67006	Bkt, Main, Weldmt, 6.7L, ISB, BBFE		each	1		
25	FSP61905	Spacer, Fan, Pulley, ISB, 19.05mm (.75")		each	1		
30	PUL67001	Pulley, Crank, ADD-ON, Cum, ISB, 6.7, SA		each	1		
40	PUL10094	Pulley, Idler, SA,94d x 18w,Blk (IP-103)		each	1		
50	SCD11617	Spacer, Col, Drl, 11.6mm x 28.6o x 17i		each	1		
60	TEN00002	Tenr, Spring, Un-Direct, 90d, 3/8 x 4.5"/3.5"		each	1		
70	KBC62651	Bag Kit, Fasteners, KMC62651/KMC62051		each	1		

Bill of Materials Listing

TransArctic Canada Inc.

7/19/2007

Page 1 of 1

Product Number		Description	Bin	Date	Weight	Uof M	Yield
Line	Component Prod#	Description		Unit	Qty		
KBC62651		Bag Kit, Fasteners, KMC62651/KMC62051		7/6/2007	3.44		0
10	BTC12060	Bolt, Hex, 12 x 1.75 x 60mm, 10.9, Plt		each	3		
12	BTC10100	Bolt, Hex, 10 x 1.5 x 100mm, 10.9, Plt		each	6		
15	BTC08100	Bolt, Hex, 8 x 1.25 x 100mm, 10.9, Plt		each	8		
20	BTS10001	Bolt, Shoulder, 10mm (89064)		each	1		
30	CSF06250	Capscrew, FH, 3/8-16 x 2.5", 9, Plt		each	1		
40	CSS12090	Capscrew, SH, 12 x 1.25 x 90mm, 12.9,BLK		each	6		
50	NTA10000	Nut, Hex, 10 x 1.5, 8.8, Plt		each	1		
60	PNS04012	Pin, Spring, 1/4" d x 3/4" lg, ST, PLT		each	1		
70	WFA12000	Washer, Flat, 12mm, 8.8, Plt		each	3		
73	WFA08000	Washer, Flat, 8mm, 8.8, Plt		each	8		
75	WFS12002	Washer, Flat, Hdn, 12mm, Stl, BLK		each	6		
80	WLA12000	Washer, Lock, 12mm, 8.8, Plt		each	3		
90	WLA10000	Washer, Lock, 10mm, 8.8, Plt		each	1		
100	WLA08000	Washer, Lock, 8mm, 8.8, Plt		each	8		

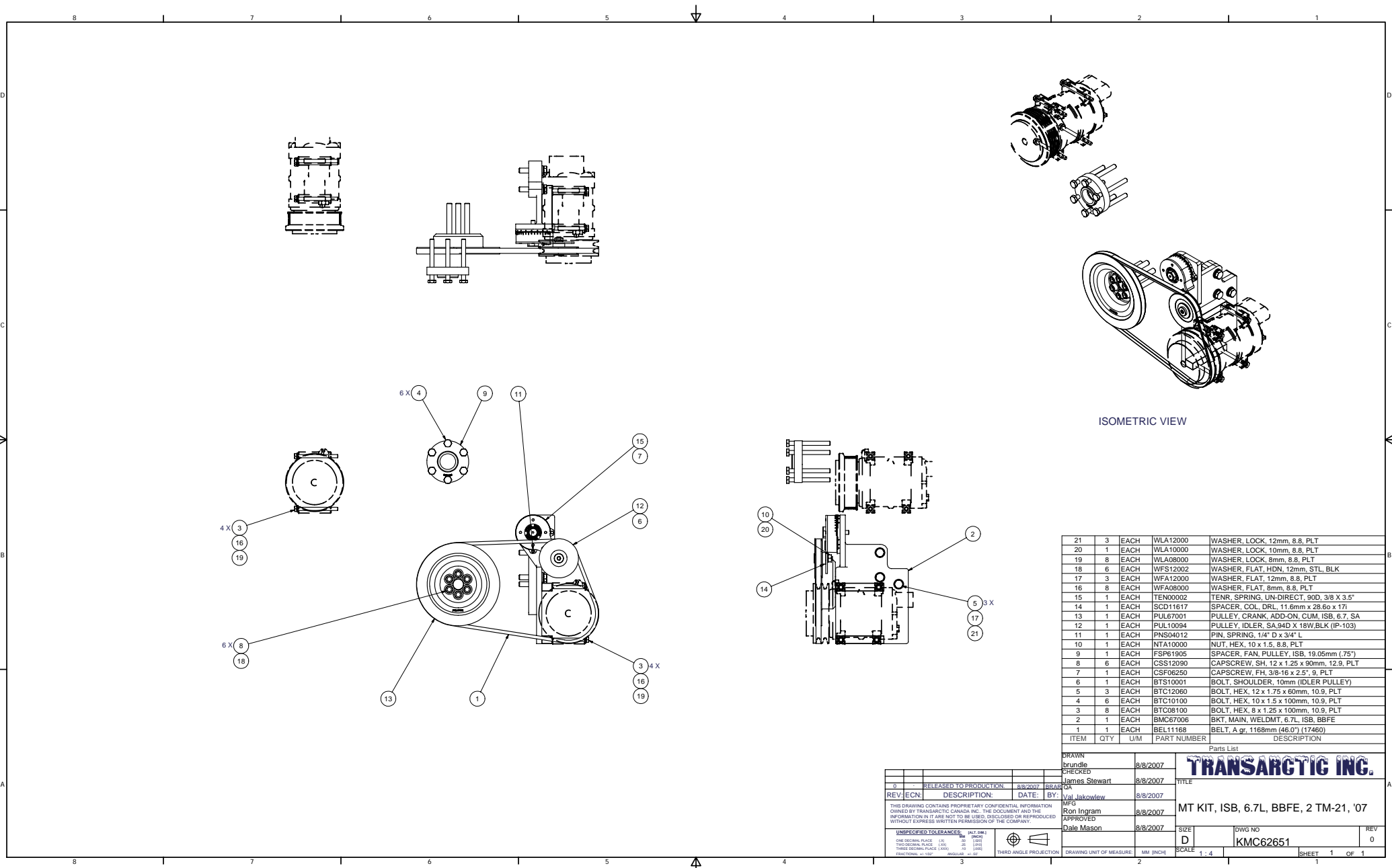

ISOMETRIC VIEW

ITEM	QTY	UM	PART NUMBER	DESCRIPTION
21	3	EACH	WLA12000	WASHER, LOCK, 12mm, 8.8, PLT
20	1	EACH	WLA10000	WASHER, LOCK, 10mm, 8.8, PLT
19	8	EACH	WLA08000	WASHER, LOCK, 8mm, 8.8, PLT
18	6	EACH	WFS12002	WASHER, FLAT, HDN, 12mm, STL, BLK
17	3	EACH	WFA12000	WASHER, FLAT, 12mm, 8.8, PLT
16	8	EACH	WFA08000	WASHER, FLAT, 8mm, 8.8, PLT
15	1	EACH	TEN00002	TENR, SPRING, UN-DIRECT, 90D, 3/8 X 3.5"
14	1	EACH	SCD11617	SPACER, COL, DRL, 11.6mm x 28.6o x 17l
13	1	EACH	PUL67001	PULLEY, CRANK, ADD-ON, CUM, ISB, 6.7, SA
12	1	EACH	PUL10094	PULLEY, IDLER, SA, 94D X 18W, BLK (IP-103)
11	1	EACH	PNS04012	PIN, SPRING, 1/4" D x 3/4" L
10	1	EACH	NTA10000	NUT, HEX, 10 x 1.5, 8.8, PLT
9	1	EACH	FSP61905	SPACER, FAN, PULLEY, ISB, 19.05mm (.75")
8	6	EACH	CS512090	CAPSCREW, SH, 12 x 1.25 x 90mm, 12.9, PLT
7	1	EACH	CSF06250	CAPSCREW, FH, 3/8-16 x 2.5", 9, PLT
6	1	EACH	BTS10001	BOLT, SHOULDER, 10mm (IDLER PULLEY)
5	3	EACH	BTC12060	BOLT, HEX, 12 x 1.75 x 60mm, 10.9, PLT
4	6	EACH	BTC10100	BOLT, HEX, 10 x 1.5 x 100mm, 10.9, PLT
3	8	EACH	BTC08100	BOLT, HEX, 8 x 1.25 x 100mm, 10.9, PLT
2	1	EACH	BMC67006	BKT, MAIN, WELDMT, 6.7L, ISB, BBFPE
1	1	EACH	BEL11168	BELT, A gr, 1168mm (46.0") (1746D)

Parts List

DRAWN	brundie	8/8/2007		
CHECKED	James Stewart	8/8/2007		
RELEASED TO PRODUCTION	8/8/2007	BRABCA		
REV	ECN	DESCRIPTION	DATE	BY
			8/8/2007	vaj_lakowicz
			8/8/2007	Ron Ingram
			8/8/2007	Dale Mason

THIS DRAWING CONTAINS PROPRIETARY CONFIDENTIAL INFORMATION OWNED BY TRANSARGTIC CANADA INC. THE DOCUMENT AND THE INFORMATION IT IS NOT TO BE USED, DISCLOSED OR REPRODUCED WITHOUT EXPRESS WRITTEN PERMISSION OF THE COMPANY.

UNSPECIFIED TOLERANCES:		FINISH	THIRD ANGLE PROJECTION
ONE DECIMAL PLACE (X.0)	30 (FRA)		
TWO DECIMAL PLACE (X.00)	30 (FRA)		
THREE DECIMAL PLACE (X.000)	30 (FRA)		
FRACTIONAL (1/16")	ANGULAR (1/2°)		

DRAWING UNIT OF MEASURE	MM (INCH)
SCALE	1:1
DWG NO	KMC62651
REV	0
SHEET	1 OF 1



MT KIT, ISB, 6.7L, BBFPE, 2 TM-21, '07

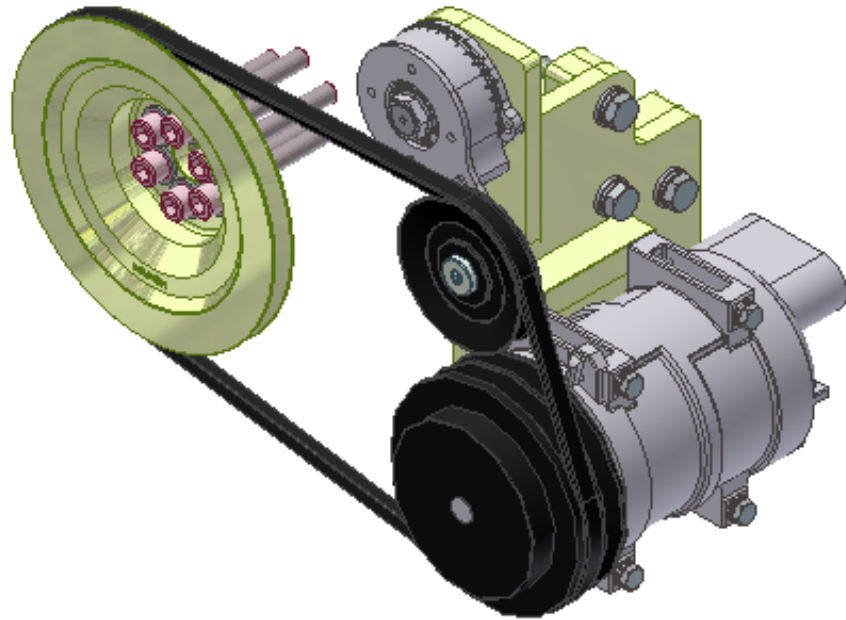
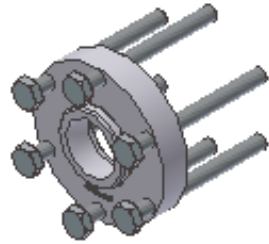
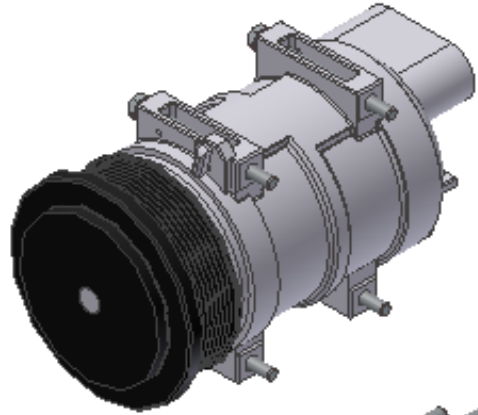

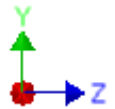
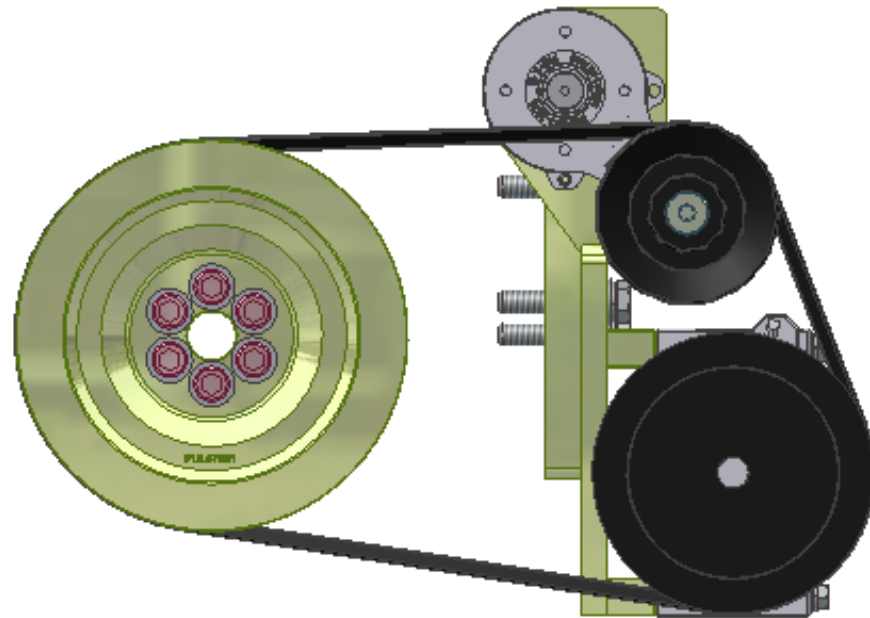
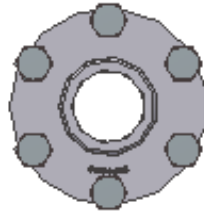
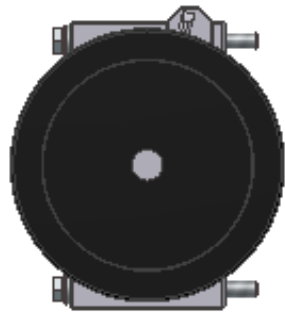

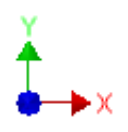
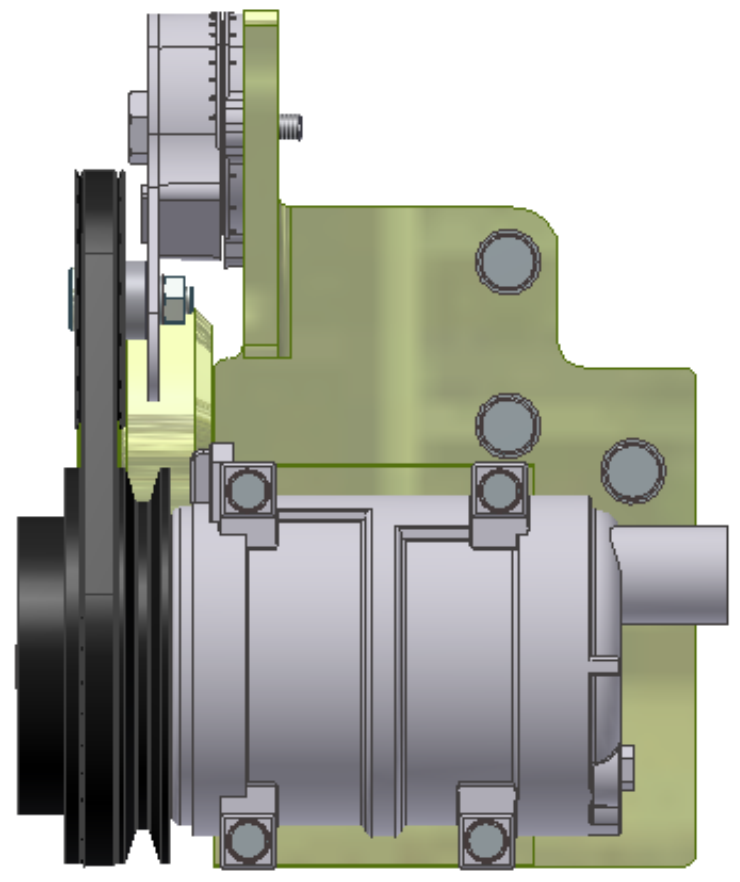
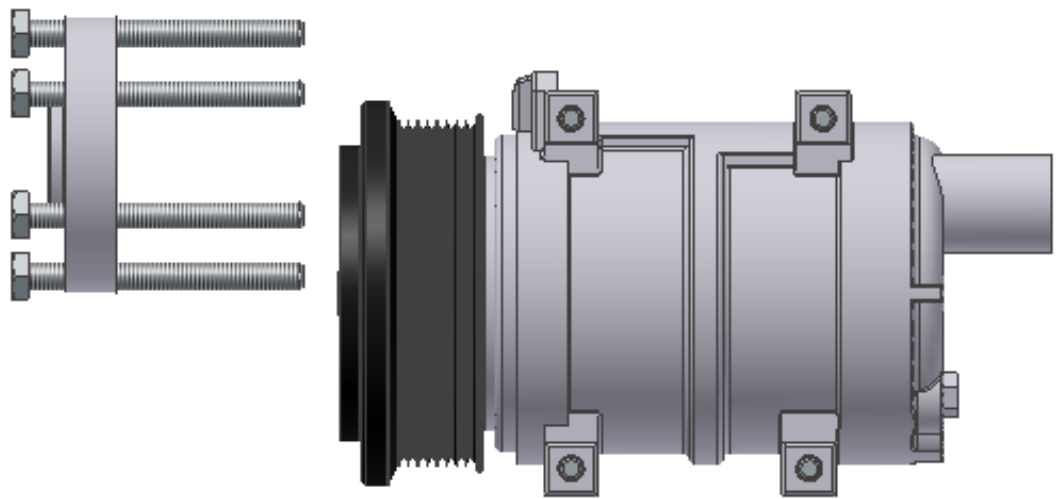

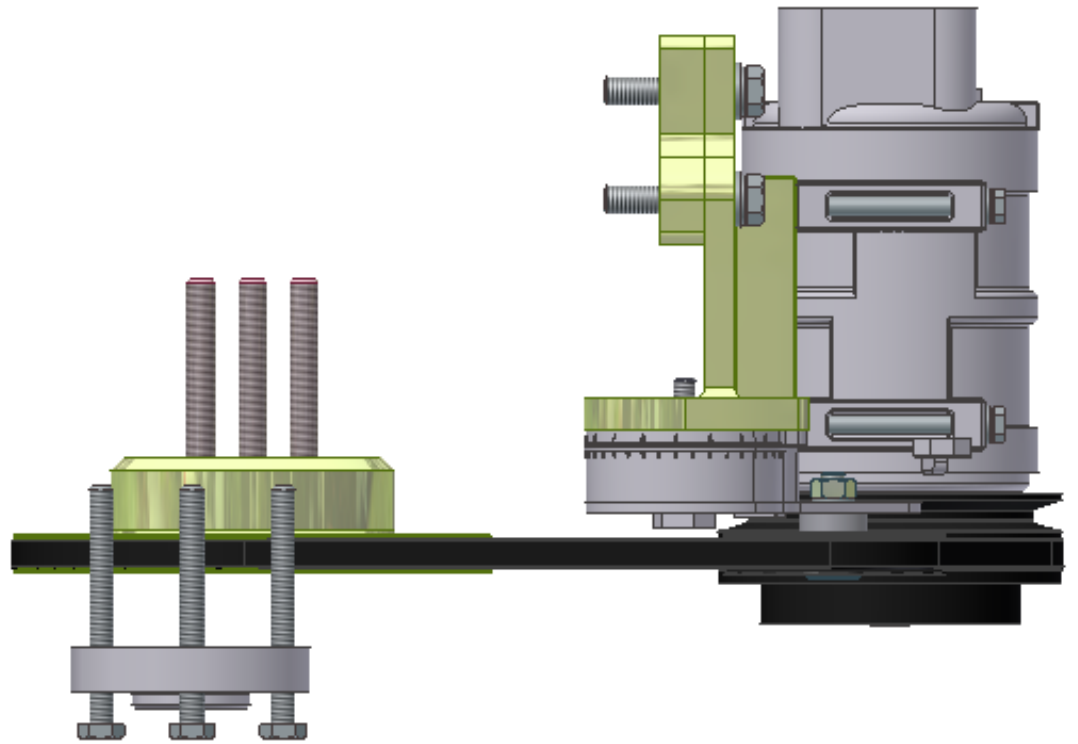
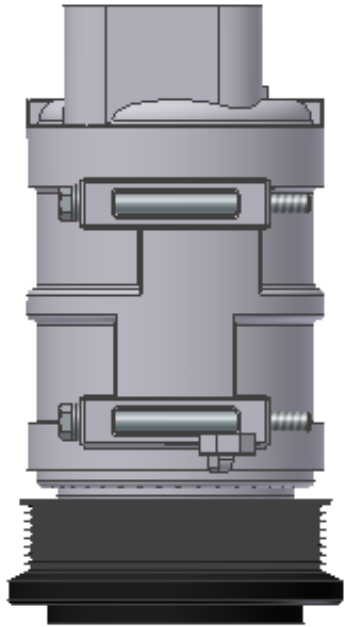

TransArctic A/C Compressor Mount Installation Disclaimer

All compressor mounts should be installed by qualified and trained personnel using proper tools and equipment in safe working conditions following industry standard guidelines for motor vehicle service and repair.

The installer of any compressor mount purchased from TransArctic must undertake all responsibility of issues arising from that compressor bracket being installed on any vehicle. As well as insure that a **proper and sufficient ground** is established between the compressors' clutches and the vehicle's engine. Mount functionality, operation and durability can all be compromised by an incompetent installation.

Due to the many different situations, parameters and application criteria, which are beyond the compressor mount manufacturer's control, TransArctic does not warrant design, durability, or operational functionality of any compressor mount improperly installed by another party.

With no implied guarantees it is the mount installer's strict responsibility to determine safety and functionality, of the compressor mount, at the time of installation.

Please contact TransArctic with any issue arising from installation so we may better improve the product. If you have any reservations about the compressor mount integrity contact TransArctic immediately at 1-877-COLD-AIR.

Mark OEM tensioner location

Install Kit

Check for Interferences

Check to ensure that the proper OEM tensioner orientation is maintained

Run engine with A/C system engaged for at least 10 minutes to run in belt

Check OEM tensioner orientation and adjust as required

Responsabilidad limitada de TransArctic en la instalación del soporte del compresor

Todos los soportes de los compresores deben ser instalados por personas calificadas y entrenadas, usando para ello los equipos y herramientas necesarios para esta labor en buenas condiciones y según las normas y guías para el servicio y/o reparación de motores de vehículos.

El instalador de los soportes comprados en TransArctic asume toda la responsabilidad de cualquier problema que surga en el soporte del compresor al vehículo; de igual manera es responsable que el cable a tierra sea conectado entre el embrague del compresor y el motor del vehículo.

Se advierte que el buen funcionamiento y la durabilidad del soporte pueden ser comprometidos por defectos en su instalación.

Debido a las diversas situaciones que se puedan presentar fuera del control del fabricante, TransArctic no garantiza el diseño, la durabilidad o el correcto funcionamiento de cualquier equipo inapropiadamente instalado por terceros.

Esta sobreentendido que el Instalador del montaje del compresor es estrictamente responsable de la seguridad y funcionamiento del equipo en el momento de la instalación.

Si tuviera algún problema o duda acerca de la instalación del soporte del compresor pongase en contacto inmediatamente con TransArctic al teléfono 1-877-COLD-AIR de modo que podamos mejorar nuestro producto.

Note la ubicación del medidor de tensión OEM

Instale el equipo

Controlar si hay interferencias.

Asegurese que el medidor de tensión mantenga la orientación justa.

Encienda el motor por lo menos 10 minutos con el sistema A/C enganchado para que la correa corra

Controle la orientación justa del medidor de tensión y ajuste a las condiciones requeridas del fabricante