

Bill of Materials Listing

TransArctic Canada Inc.

1/11/2011
Page 1 of 1

Product Number	Description	Date	Weight	Uof M	Yield
Line Component Prod#	Description	Bin Unit	Qty		
KMN81072	Mt. Kit, MF DT, CE300, TM-16, '10		11/10/2010	3.59	0
10 BEL02184	Belt, 10gr, 2184mm (86") (5100860)	each	1		
20 BMN80038	Bkt, Rad Hose, PMax DT, CE300	each	1		
30 PUL80074	Pulley, Idler, B/S, Wide, 76d (89102)	each	1		
40 SCD46010	Spacer, Col, Drl, 46mm x 25.4o x 10.32i	each	1		
50 SLV17010	Sleeve, Pulley, 16.9o x 22.23mm x 10.32i	each	1		
60 CLP20040	Clamp, "P" type, #40, 1/2"w, 2 1/2", PC	each	1		
70 CLP36001	Clamp, Gear, #36, 1 13/16-2 3/4 (46/70mm)	each	2		
80 KBN81372	Bag Kit, Fasteners, KMN81372 & KMN81072	each	1		

Bill of Materials Listing

TransArctic Canada Inc.

1/11/2011
Page 1 of 1

Product Number	Description	Date	Weight	Uof M	Yield
Line Component Prod#	Description	Bin Unit	Qty		
KBN81372	Bag Kit, Fasteners, KMN81372 & KMN81072	5/3/2007	0.97		0
5	BTC10100	Bolt, Hex, 10 x 1.5 x 100mm, 10.9, Plt, FT	each	1	
10	BTC08110	Bolt, Hex, 8 x 1.25 x 110mm, 10.9, Plt	each	4	
20	BTC08100	Bolt, Hex, 8 x 1.25 x 100mm, 10.9, Plt	each	4	
50	WFA08000	Washer, Flat, 8mm, 8.8, Plt	each	4	
60	WLA08000	Washer, Lock, 8mm, 8.8, Plt	each	5	
80	WLA10000	Washer, Lock, 10mm, 8.8, Plt	each	1	
130	BTP04075	Bolt, Hex, 1/4-20unc, .75", 5, Plt	each	1	
135	NTA08000	Nut, Hex, 8 x 1.25, 8.8, Plt	each	1	
140	NTP04000	Nut, Hex, 1/4-20unc, 5, Plt	each	1	
150	WFS04003	Washer, Flat, 1/4", 2, USS, Plt	each	1	

8 7 6 5 4 3 2 1

D

C

B

A

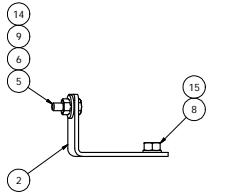
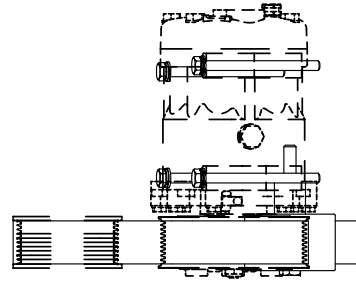

15 13 3 4 PLCS.

NOTE:
CARRIER COMPRESSOR
PART# 76-G2287-xx

2x 7

SEE NOTE # 3.

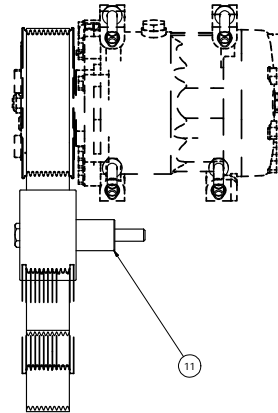
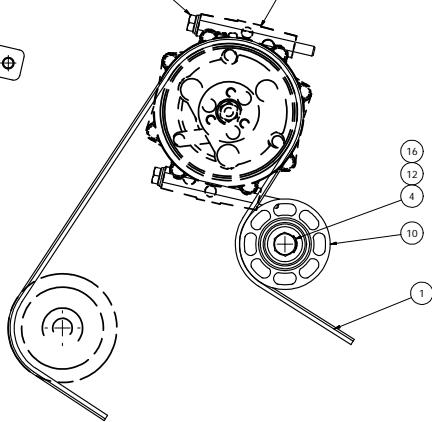
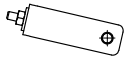

REFER TO PHOTOGRAPHS FOR MOUNTING.

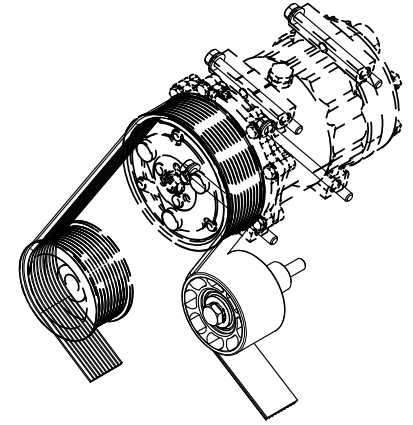

ISOMETRIC VIEW

NOTES:

- 1) USE SERVICABLE THREADLOCKER ON ALL FASTENERS TO ENGINE COMPONENTS AND TORQUE ALL BOLTS TO S.A.E. SPECIFICATIONS.
- 2) SEE "TRANSARGTIC A/C COMPRESSOR MOUNT INSTALLATION DISCLAIMER"
- 3) MODIFY EXISTING RADATOR HOSE ON PASSENGER SIDE (TO CLEAR BELT & COMPRESSOR.) BY REMOVING HOSE AND FLIPPING END FOR END AND THEN RE-INSTALL ON THE ENGINE WITH THE INTERNAL WIRE COIL REINFORCEMENT IN AT LEAST THE TOP HORIZONTAL PORTION OF THE RAD HOSE. (USING NEW BRKT SUPPLIED. AND (2) GEAR CLAMPS AS NEEDED.)

ITEM	QTY	U/M	PART NUMBER	DESCRIPTION
16	1	EACH	WL1A0000	WASHER, LOCK, 10mm, 8.8, PLT
15	5	EACH	WLA08000	WASHER, LOCK, 8mm, 8.8, PLT
14	1	EACH	WFS04003	WASHER, FLAT, 1/4", 2, USS, PLT
13	4	EACH	WFA08000	WASHER, FLAT, 8mm, 8.8, PLT
12	1	EACH	SLV17010	SLEEVE, PULLEY, 16.9x 22.23mm x 10.32i
11	1	EACH	SCD46010	SPACER, COL, DRL, 46mm x 25.4o x 10.32i
10	1	EACH	PUL80074	PULLEY, IDLER, BACKSIDE, P8, 74D, 46.27W
9	1	EACH	NTP04000	NUT, HEX, 1/4-20UNC, 5, PLT
8	1	EACH	NTA08000	NUT, HEX, 8 x 1.25, 8.8 PLT
7	2	EACH	CLP36001	CLAMP, GEAR, #36, 1 13/16- 2 3/4 (46/70 mm)
6	1	EACH	CLP20040	CLAMP, "P" TYPE, #40, 1/2" w, 2 1/2", PC
5	1	EACH	BTP04075	BOLT, HEX, 1/4-20UNC, .75", 5, PLT
4	1	EACH	BTC10100	BOLT, HEX, 10 x 1.5 x 100mm, 10.9, PLT
3	4	EACH	BTC08100	BOLT, HEX, 8 x 1.25 x 100mm, 10.9, PLT
2	1	EACH	BMN80038	BKT, RAD HOSE, PMAX DT, CE300
1	1	EACH	BELO2184	BELT, 10gr, 2184mm (86")

BILL OF MATERIALS

DRAWN	11/25/2010	VAL	GA
U	RELEASED TO PRODUCTION	11/25/2010	VAL
REVIEW	DESCRIPTION:	DATE:	BY:
			James Stewart
			Ron Ingram
			Dale Mason



TITLE
MT. KIT, MFORCE DT, CE300, TM-16,
*10

UNSPECIFIED TOLERANCES:	MM (INCH)	THIRD ANGLE PROJECTION
ONE DECIMAL PLACE (.X)	30 (1/8)	
TWO DECIMAL PLACE (.XX)	10 (1/32)	
THREE DECIMAL PLACE (.XXX)	3 (1/64)	
FRACTIONAL (1/16)	16 (1/16)	

DWG NO
KMN81072

SCALE 1:2 SHEET 1 OF 1

8 7 6 5 4 3 2 1

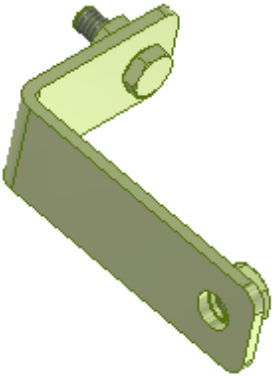

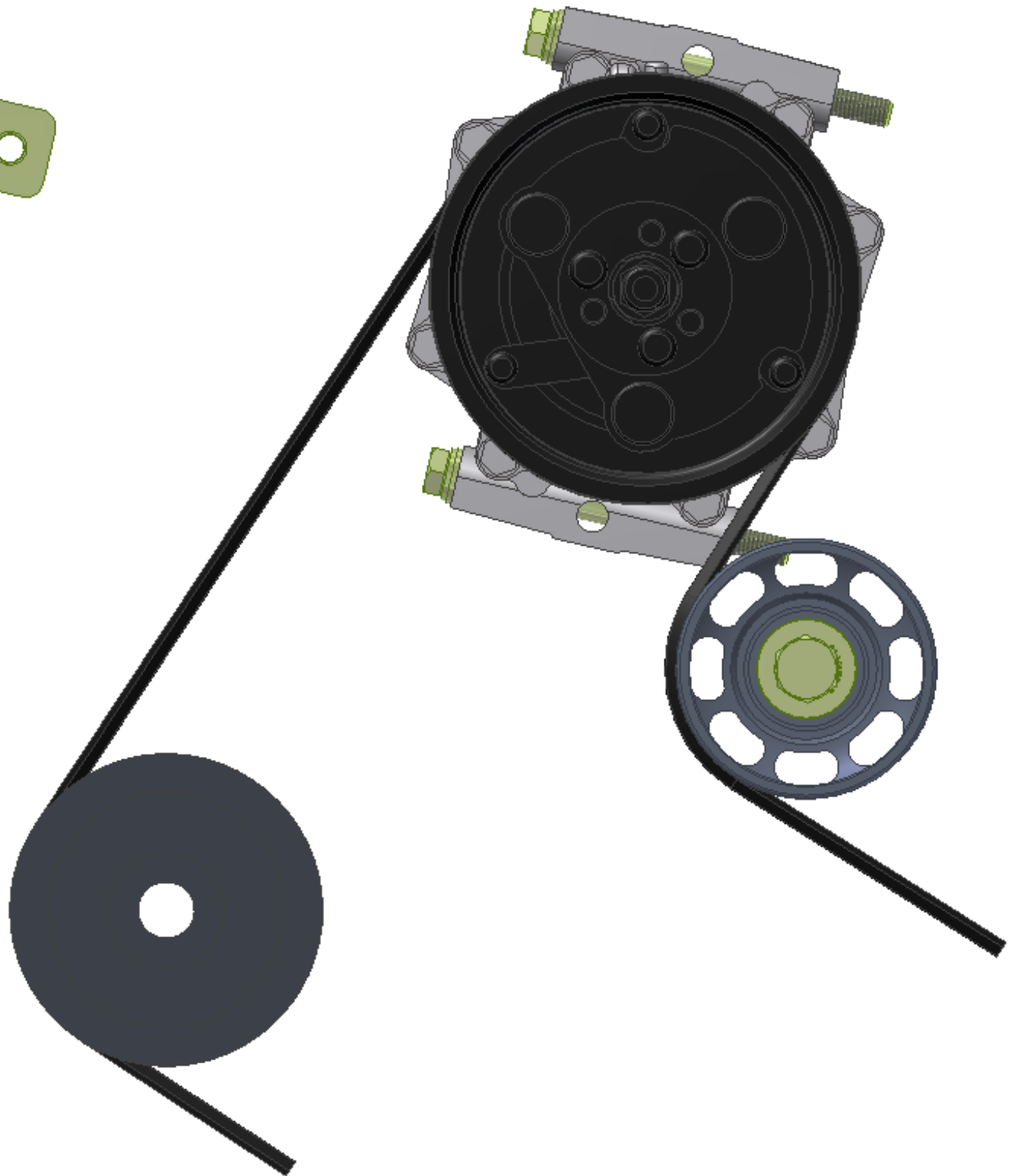
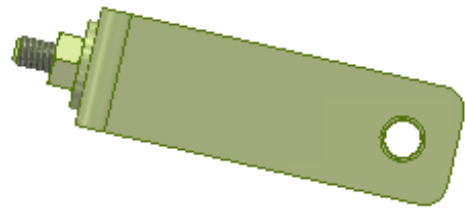

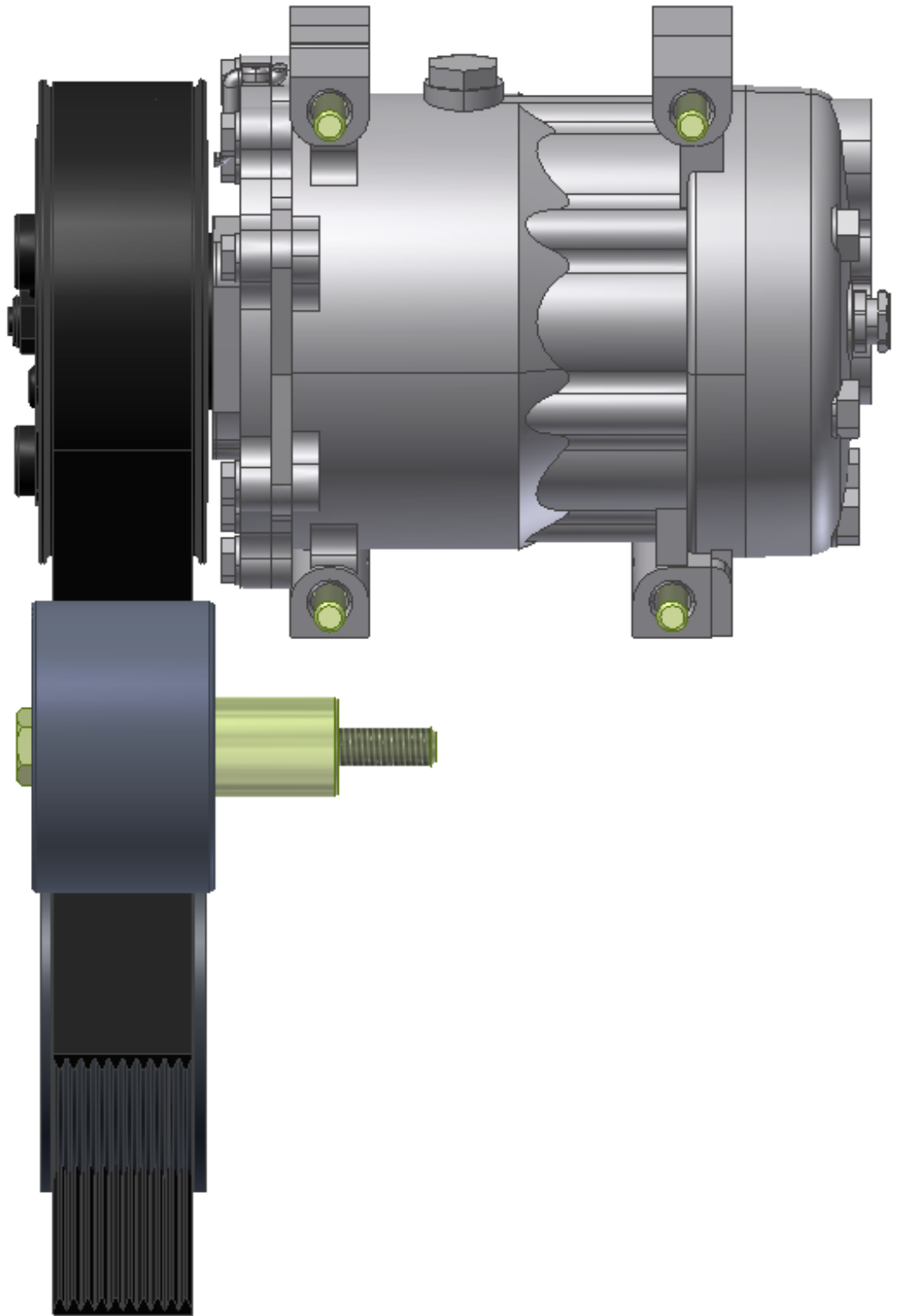
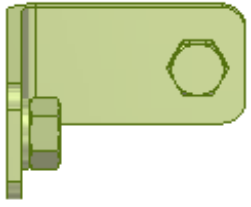

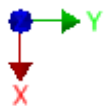
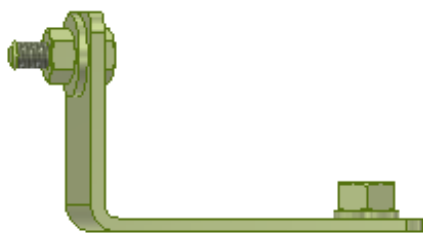
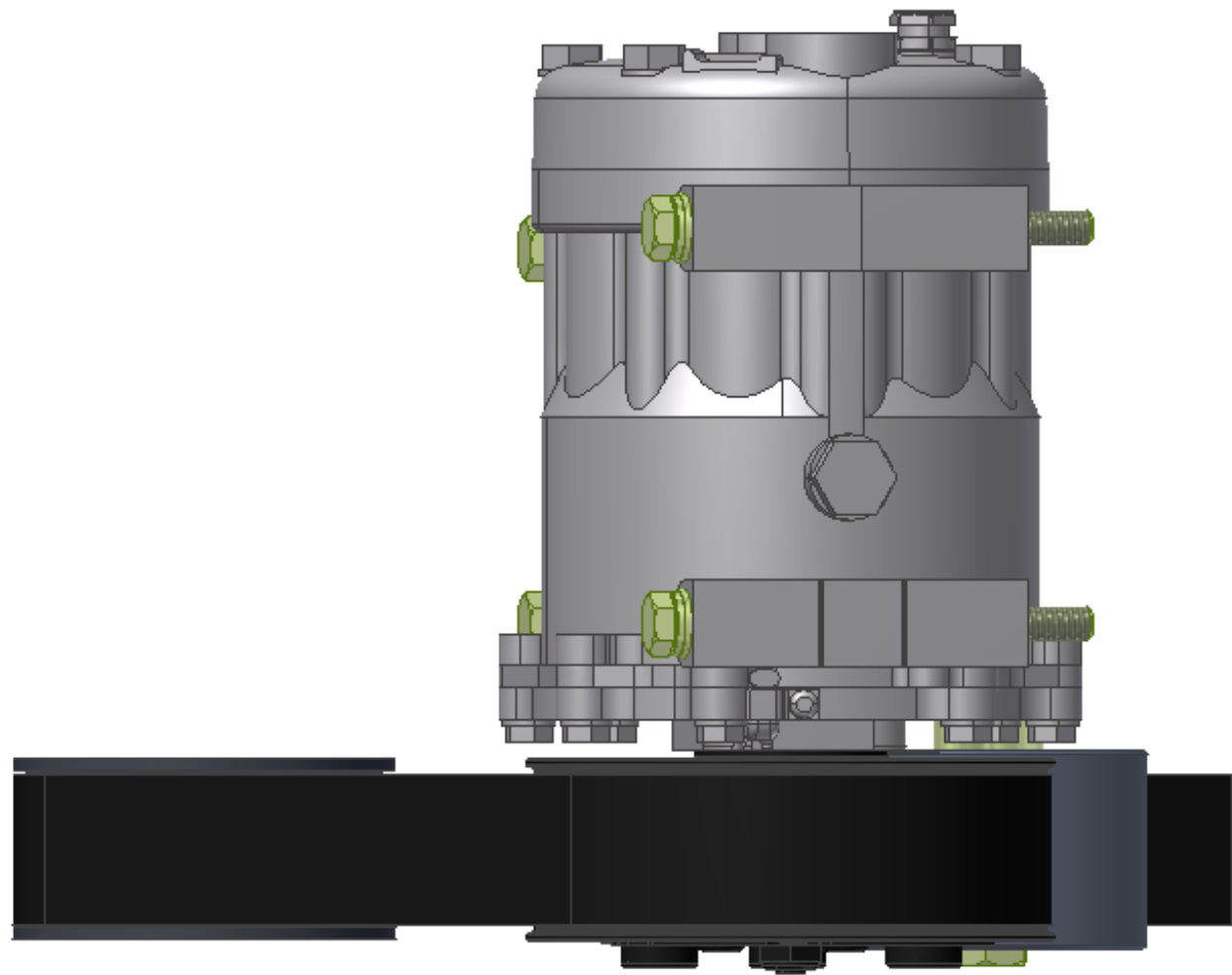

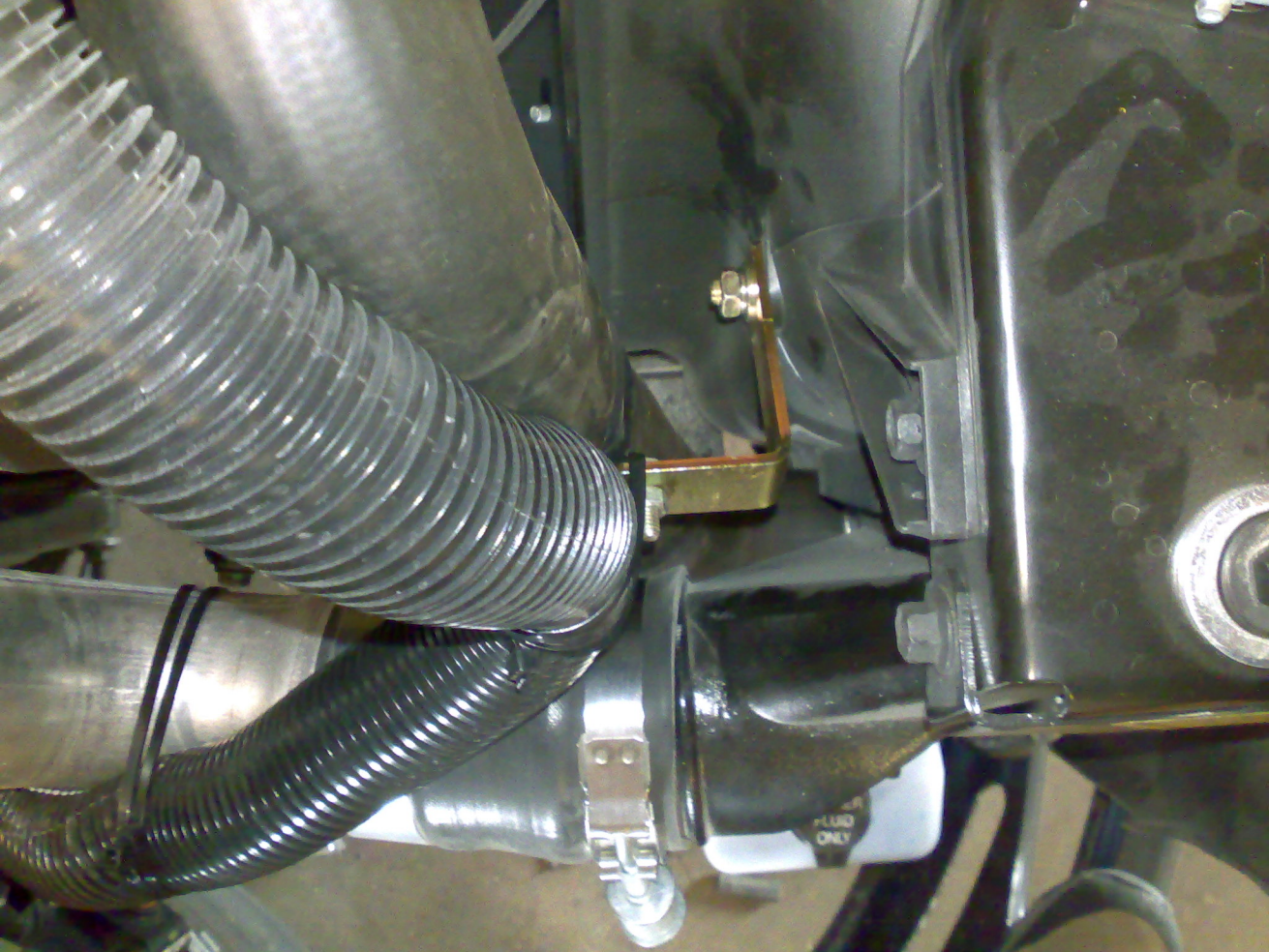

TransArctic A/C Compressor Mount Installation Disclaimer

All compressor mounts should be installed by qualified and trained personnel using proper tools and equipment in safe working conditions following industry standard guidelines for motor vehicle service and repair.

The installer of any compressor mount purchased from TransArctic must undertake all responsibility of issues arising from that compressor bracket being installed on any vehicle. As well as insure that a **proper and sufficient ground** is established between the compressors' clutches and the vehicle's engine. Mount functionality, operation and durability can all be compromised by an incompetent installation.

Due to the many different situations, parameters and application criteria, which are beyond the compressor mount manufacturer's control, TransArctic does not warrant design, durability, or operational functionality of any compressor mount improperly installed by another party.

With no implied guarantees it is the mount installer's strict responsibility to determine safety and functionality, of the compressor mount, at the time of installation.

Please contact TransArctic with any issue arising from installation so we may better improve the product. If you have any reservations about the compressor mount integrity contact TransArctic immediately at 1-877-COLD-AIR.

Mark OEM tensioner location

Install Kit

Check for Interferences

Check to ensure that the proper OEM tensioner orientation is maintained

Run engine with A/C system engaged for at least 10 minutes to run in belt

Check OEM tensioner orientation and adjust as required

Responsabilidad limitada de TransArctic en la instalación del soporte del compresor

Todos los soportes de los compresores deben ser instalados por personas calificadas y entrenadas, usando para ello los equipos y herramientas necesarios para esta labor en buenas condiciones y según las normas y guías para el servicio y/o reparación de motores de vehículos.

El instalador de los soportes comprados en TransArctic asume toda la responsabilidad de cualquier problema que surga en el soporte del compresor al vehículo; de igual manera es responsable que el cable a tierra sea conectado entre el embrague del compresor y el motor del vehículo.

Se advierte que el buen funcionamiento y la durabilidad del soporte pueden ser comprometidos por defectos en su instalación.

Debido a las diversas situaciones que se puedan presentar fuera del control del fabricante, TransArctic no garantiza el diseño, la durabilidad o el correcto funcionamiento de cualquier equipo inapropiadamente instalado por terceros.

Esta sobreentendido que el Instalador del montaje del compresor es estrictamente responsable de la seguridad y funcionamiento del equipo en el momento de la instalación.

Si tuviera algún problema o duda acerca de la instalación del soporte del compresor pongase en contacto inmediatamente con TransArctic al teléfono 1-877-COLD-AIR de modo que podamos mejorar nuestro producto.

Note la ubicación del medidor de tensión OEM

Instale el equipo

Controlar si hay interferencias.

Asegurese que el medidor de tensión mantenga la orientación justa.

Encienda el motor por lo menos 10 minutos con el sistema A/C enganchado para que la correa corra

Controle la orientación justa del medidor de tensión y ajuste a las condiciones requeridas del fabricante