

Bill of Materials Listing

TransArctic Canada Inc.

7/1/2008
Page 1 of 1

Product Number	Description	Date	Weight	Uof M	Yield
Line Component Prod#	Description	Bin Unit	Qty		
KMN82030	Mt. Kit, MForce DT, RE300, 2 TM-16, '07	12/11/07	85.76		0
10	BEL11473				
	Belt, A gr, 1473mm (58") (17580)	each	1		
20	BEL11308				
	Belt, A gr, 1308mm (51.5") (17515)	each	1		
30	BMN80053				
	Bkt, Main, Weldm't, ICRE, Dual TM-21	each	1		
33	BMN80059				
	Bkt, Spacer Plate, RE300	each	1		
35	BMS16022				
	Bkt, TM-16 Spacer Plate	each	2		
40	PUL76021				
	Pulley, Crank, Nav DT, 7.6L, 2A/X,8" D/A	each	1		
50	PUL10094				
	Pulley, Idler, SA,94d x 18w,Blk (IP-103)	each	2		
60	SCD12710				
	Spacer, Col, Drl, 12.7mm x 25.4o x10.32i	each	2		
70	SLV17040				
	Sleeve, Pulley, 16.9o x 14.29mm x 10.08i	each	2		
80	TEN00002				
	Tenr, Spring, Un-Direct, 90d, 3/8 x 4.5"/3.5"	each	2		
90	KBN82030				
	Bag Kit, Fasteners, KMN82030	each	1		

Bill of Materials Listing

TransArctic Canada Inc.

7/1/2008
Page 1 of 1

Product Number	Description	Date	Weight	Uof M	Yield
Line Component Prod#	Description	Bin Unit	Qty		
KBN82030	Bag Kit, Fasteners, KMN82030	10/17/07	4.21		0
10 BTC10065	Bolt, Hex, 10 x 1.5 x 65mm, 10.9, Plt,FT	each	6		
20 BTC10045	Bolt, Hex, 10 x 1.5 x 45mm, 10.9, Plt	each	2		
25 BTC08110	Bolt, Hex, 8 x 1.25 x 110mm, 10.9, Plt	each	4		
30 BTC08100	Bolt, Hex, 8 x 1.25 x 100mm, 10.9, Plt	each	4		
40 BTQ12501	Bolt, Hex, 3/4- 16unf, 5", 8, Plt	each	1		
50 BTQ12351	Bolt, Hex, 3/4- 16unf, 3.5", 8, Plt	each	1		
60 BTQ10351	Bolt, Hex, 5/8-18unf, 3.5", 8, PLT	each	1		
70 BTQ10301	Bolt, Hex, 5/8-18unf, 3", 8, PLT	each	1		
80 BTQ08301	Bolt, Hex, 1/2-20unf, 3", 8, Plt	each	1		
90 CSF10046	Capscrew, FH, 10 x 1.5 x 45mm, 10.9,Plt	each	2		
100 CSF06250	Capscrew, FH, 3/8-16 x 2.5", Alloy, Plt	each	2		
110 NTA10000	Nut, Hex, 10 x 1.5, 8.8, Plt	each	2		
120 NTP06000	Nut, Hex, 3/8-16unc, 5, Plt	each	2		
130 WFA10000	Washer, Flat, 10mm, 8.8, Plt	each	8		
140 WFA08000	Washer, Flat, 8mm, 8.8, Plt	each	8		
150 WFQ12000	Washer, Flat, 3/4", 8, Plt	each	1		
160 WFQ10000	Washer, Flat, 5/8", 8, Plt	each	1		
170 WFQ08000	Washer, Flat, 1/2", 8, Plt	each	1		
180 WLA10000	Washer, Lock, 10mm, 8.8, Plt	each	4		
190 WLA08000	Washer, Lock, 8mm, 8.8, Plt	each	8		
200 WLP06000	Washer, Lock, 3/8", 5, Plt	each	2		

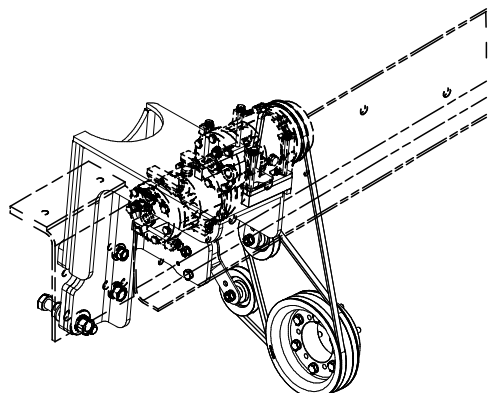

ISOMETRIC VIEW

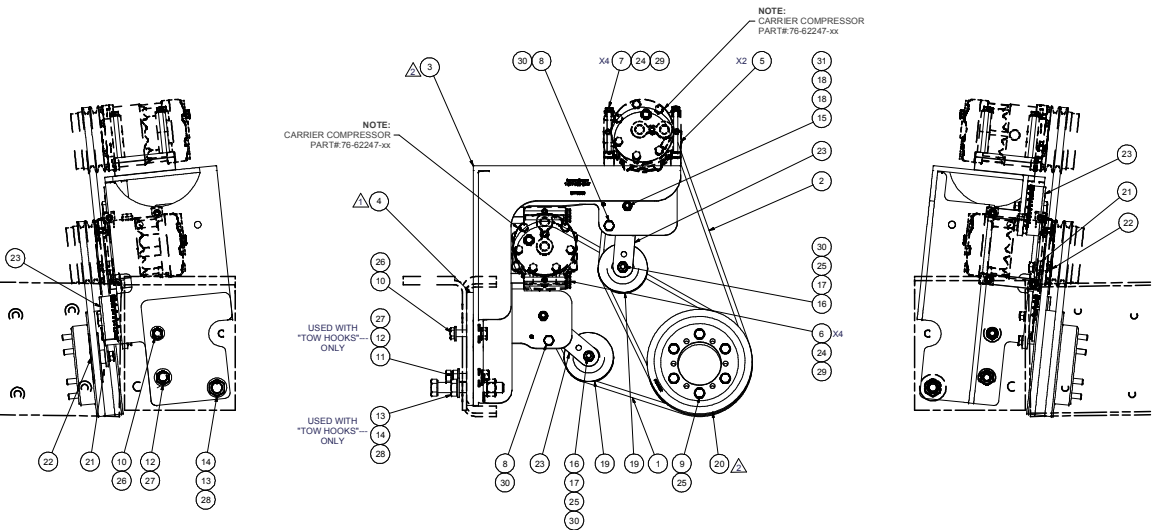
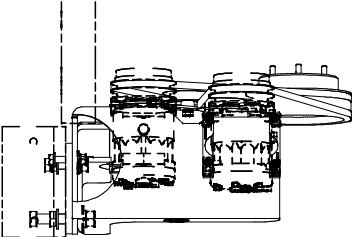

NOTES:
1) USE SERVICABLE THREADLOCKER ON ALL FASTENERS TO ENGINE COMPONENTS AND TORQUE ALL BOLTS TO S.A.E. SPECIFICATIONS.

2) SEE "TRANSARGTIC A/C COMPRESSOR MOUNT INSTALLATION DISCLAIMER"

ITEM	QTY	U/M	PART NUMBER	DESCRIPTION
31	2	EACH	WLA06000	WASHER LOCK 3/8" S. PLT
30	4	EACH	WLA10000	WASHER LOCK 10mm 8.8 PLT
29	8	EACH	WLA08000	WASHER LOCK 8mm 8.8 PLT
28	1	EACH	WFG12000	WASHER FLAT 3/4" 8 PLT
27	1	EACH	WFG10000	WASHER FLAT 5/8" 8 PLT
26	1	EACH	WFO08000	WASHER FLAT 1/2" 8 PLT
25	8	EACH	WFA10000	WASHER FLAT 10mm 8.8 PLT
24	8	EACH	WFA08000	WASHER FLAT 8mm 8.8 PLT
23	2	EACH	TEN00002	TENR. SPRING UN-DIRECT 90D 3/8 X 3 5"
22	2	EACH	SLV17040	SLEEVE PULLEY 16.90 x 14.29mm x 10.08
21	2	EACH	SCD12710	SPACER COL. DRL. 12.7mm x 25.40 x10.32
20	1	EACH	PUL76021	PULLEY CRANK NAV DT. 7.6L 2A/X.8" DIA
19	2	EACH	PUL10094	PULLEY IDLER SA.IND X 1BW.BLK (IP-103)
18	2	EACH	NTF06000	NUT HEX 3/8-16UNC. S. PLT
17	2	EACH	NTA10000	NUT HEX 10 x 1.5 8.8 PLT
16	2	EACH	CSF10046	CAPSCREW FH 10 x 1.5 x 45mm 10.9 PLT
15	2	EACH	CSF06260	CAPSCREW FH 3/8-16 x 2.5" 9 PLT
14	1	EACH	BTQ12901	BOLT HEX 3/4-16UNF x 5.00 8 PLT
13	1	EACH	BTQ12351	BOLT HEX 3/4-16UNF x 3.50" 8 PLT
12	1	EACH	BTQ10351	BOLT HEX 5/8-18UNF x 3.50 8 PLT
11	1	EACH	BTQ10301	BOLT HEX 5/8-18UNF x 3.00 8 PLT
10	1	EACH	BTQ08301	BOLT HEX 1/2-20UNF x 3.00 8 PLT
9	6	EACH	BTQ10065	BOLT HEX 10 x 1.5 x 65mm 10.9 PLT
8	2	EACH	BTQ10045	BOLT HEX 10 x 1.5 x 45mm 10.9 PLT
7	4	EACH	BTQ08110	BOLT HEX 8 x 1.25 x 110mm 10.9 PLT
6	4	EACH	BTQ08100	BOLT HEX 8 x 1.25 x 100mm 10.9 PLT
5	2	EACH	BMS16022	BKT TM-16 SPACER PLATE
4	1	EACH	BMN60059	BKT SPACER PL RE300
3	1	EACH	BMN60053	BKT MAIN WELDMT DRE DUAL TM-21
2	1	EACH	BEL11473	BELT A gr. 1473mm (58")
1	1	EACH	BEL11308	BELT A gr. 1308mm (51.5")

2	PL-76218 BANNING HAS BEEN REVISED	1/26/2008	JRS	
1	REVISION REQUIRED ACCORD BANNING	1/26/2008	JRS	
0	RECEIVED BY PRODUCTION	1/26/2008	JRS	
REV	ECN	DESCRIPTION	DATE	BY
			01/26/08	James Stewart
			1/26/2008	Ron Ingram
			1/26/2008	Dale Mason

THIS DRAWING CONTAINS PROPRIETARY CONFIDENTIAL INFORMATION OWNED BY TRANSARGTIC CANADA INC. THE DOCUMENT AND THE INFORMATION IN IT ARE NOT TO BE USED, DISCLOSED OR REPRODUCED WITHOUT EXPRESS WRITTEN PERMISSION OF THE COMPANY.

UNSPECIFIED TOLERANCES: ALL DIMENSIONS UNLESS OTHERWISE SPECIFIED SHALL BE AS SHOWN

THIRD ANGLE PROJECTION

DRAWING UNIT OF MEASURE: MM (INCH)

SCALE: 1:2

DWG NO: KMN82030

REV: 2

SHEET 1 OF 1

TRANSARGTIC INC.

MT. KIT, MForce DT, RE300, 2 TM-16, 07

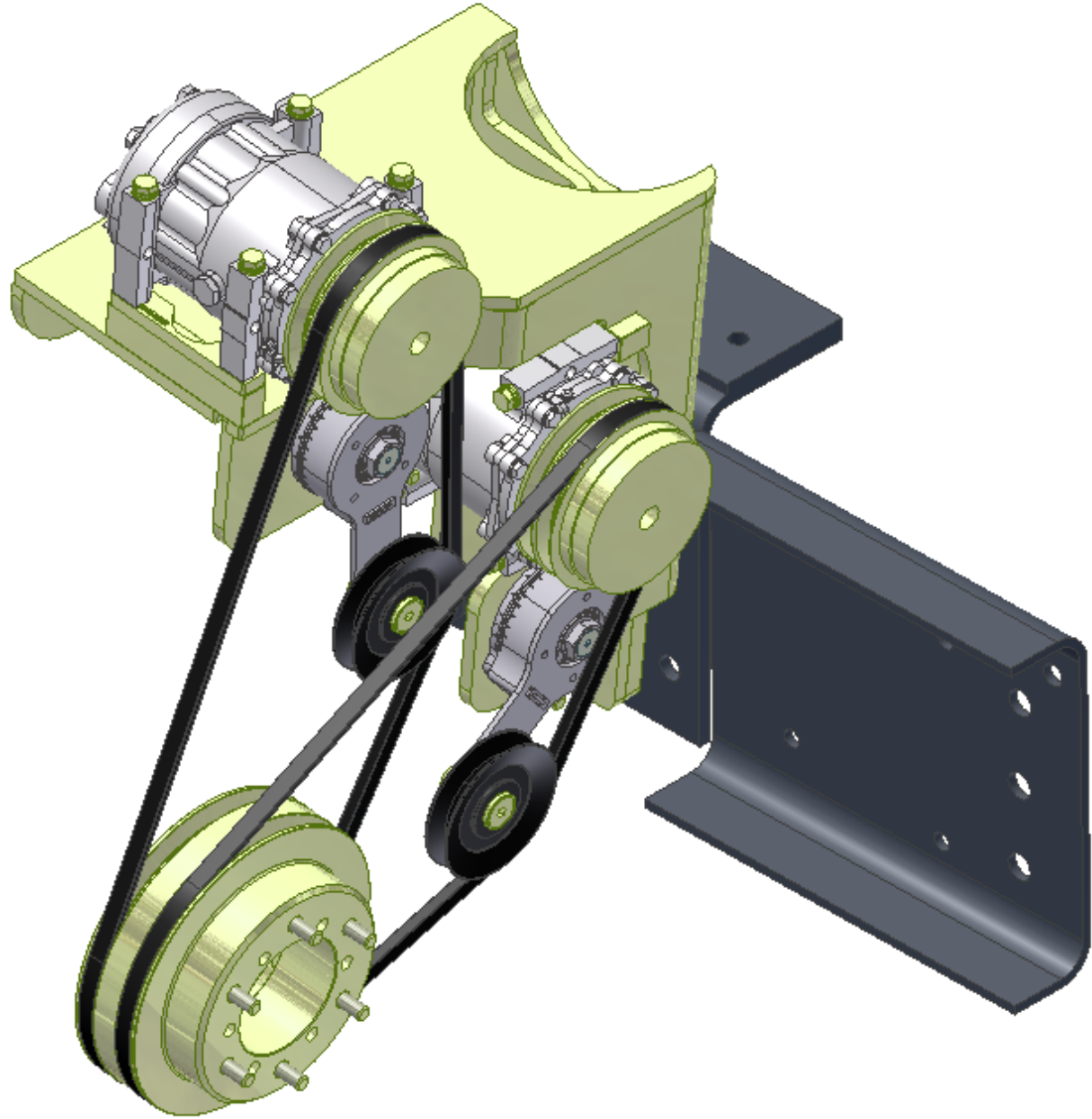

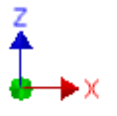
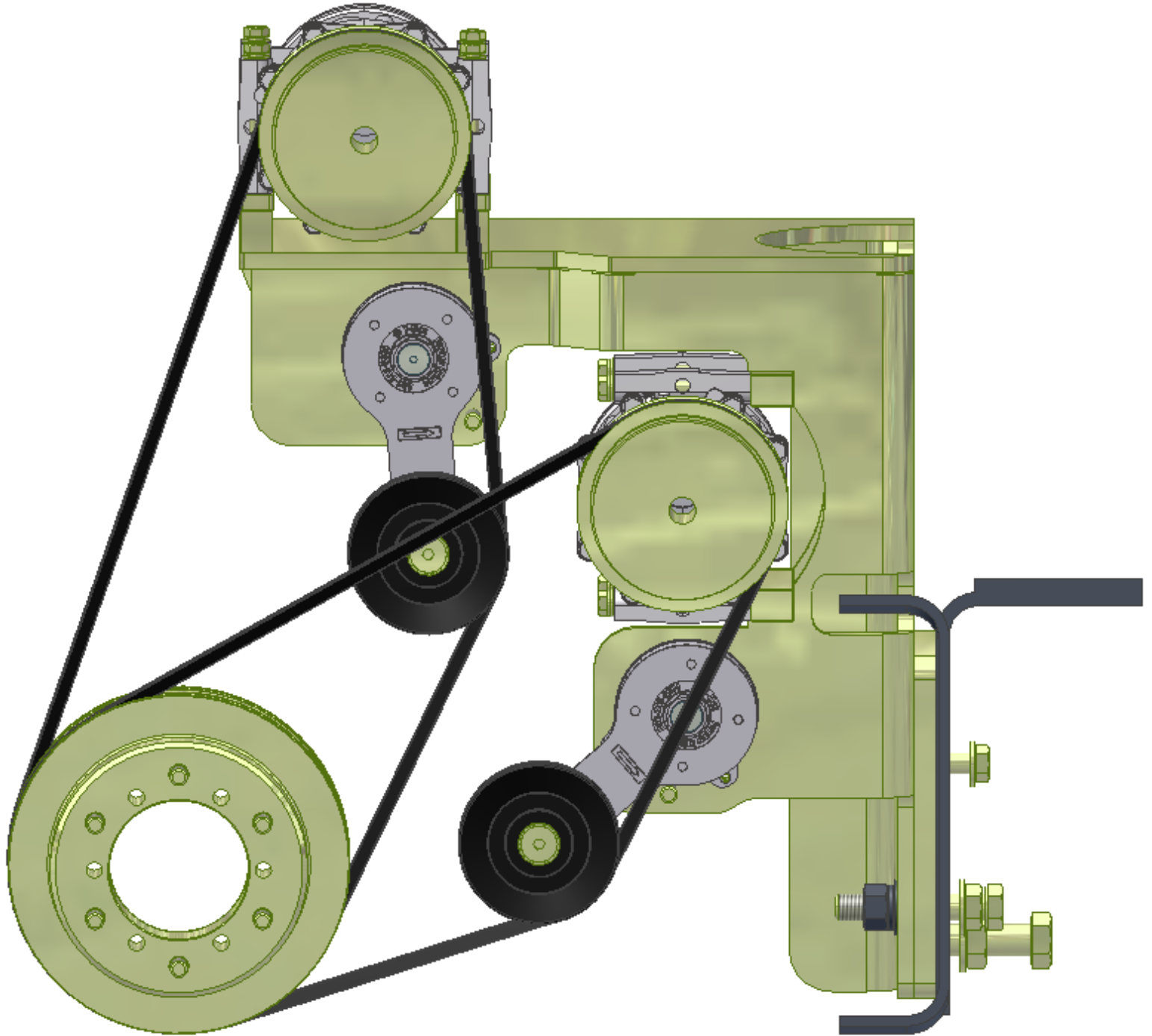

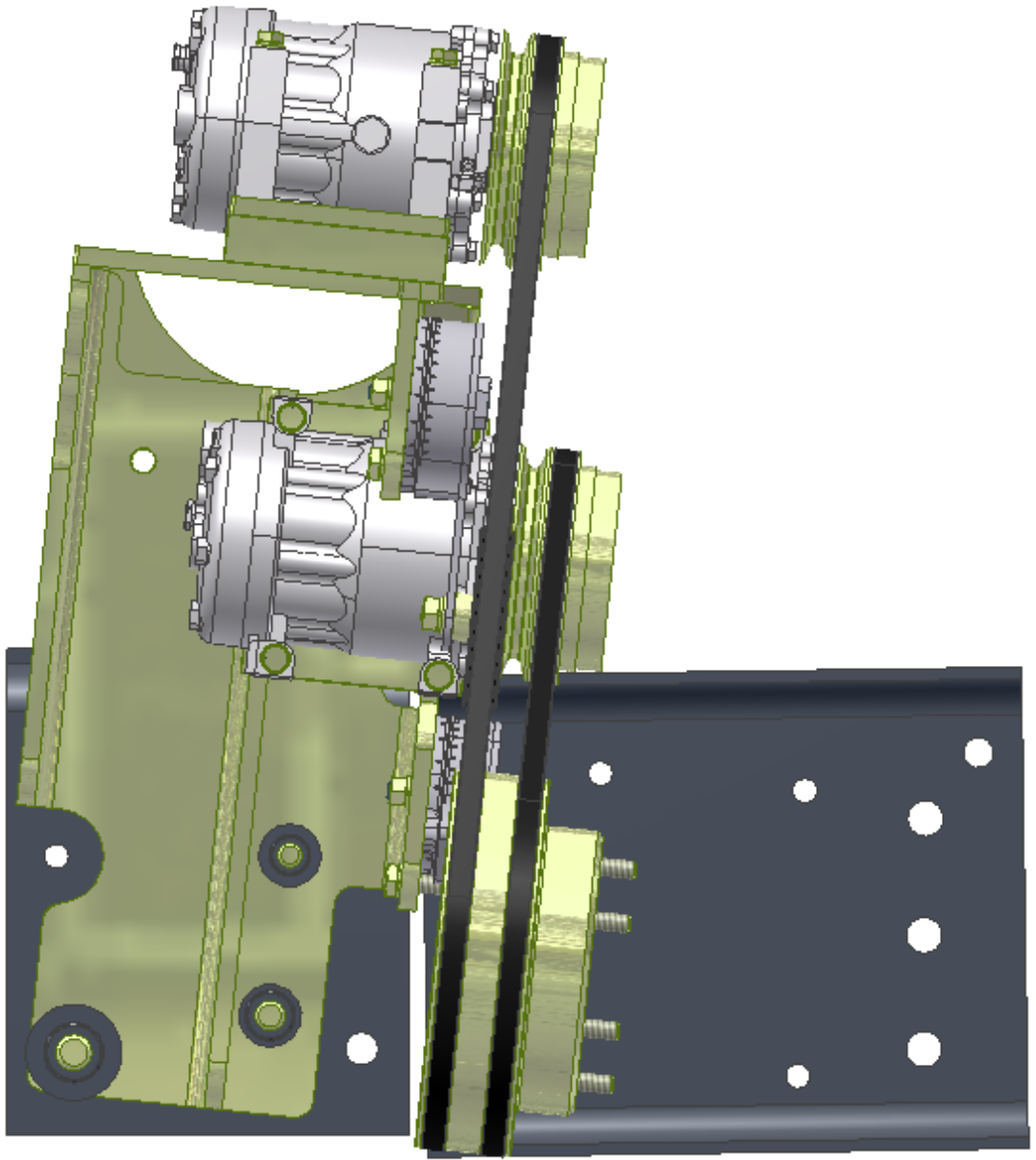

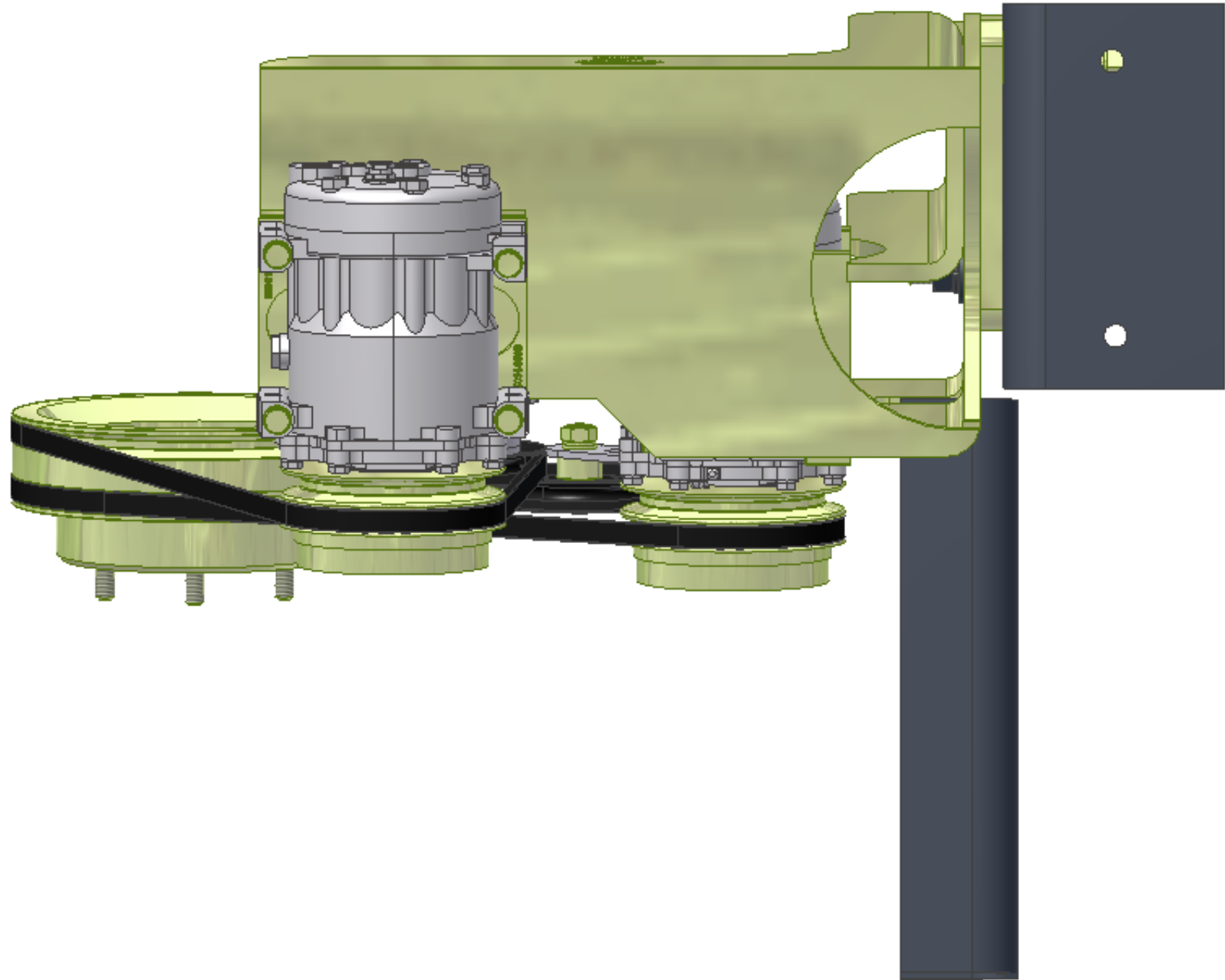

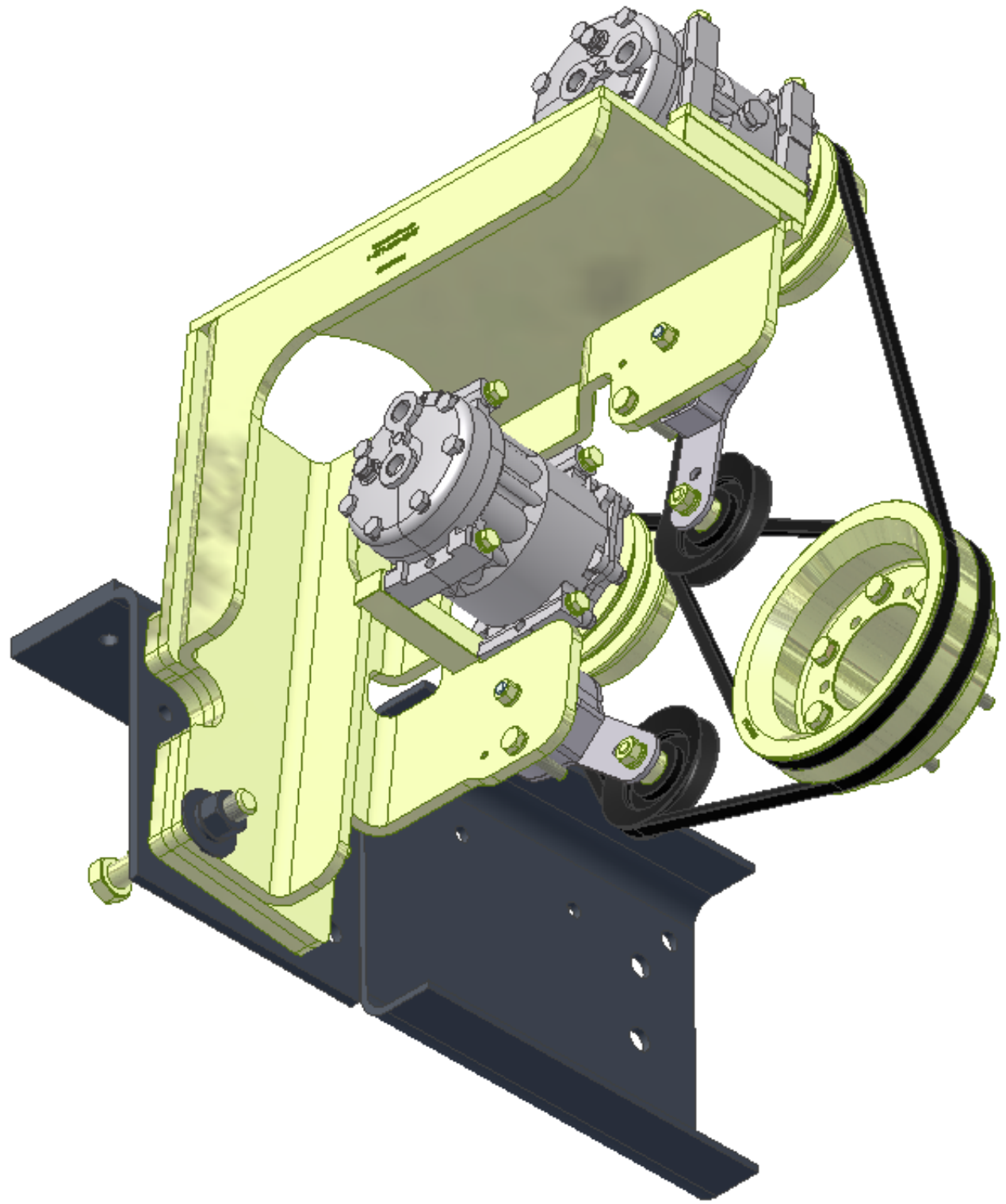

TransArctic A/C Compressor Mount Installation Disclaimer

All compressor mounts should be installed by qualified and trained personnel using proper tools and equipment in safe working conditions following industry standard guidelines for motor vehicle service and repair.

The installer of any compressor mount purchased from TransArctic must undertake all responsibility of issues arising from that compressor bracket being installed on any vehicle. As well as insure that a **proper and sufficient ground** is established between the compressors' clutches and the vehicle's engine. Mount functionality, operation and durability can all be compromised by an incompetent installation.

Due to the many different situations, parameters and application criteria, which are beyond the compressor mount manufacturer's control, TransArctic does not warrant design, durability, or operational functionality of any compressor mount improperly installed by another party.

With no implied guarantees it is the mount installer's strict responsibility to determine safety and functionality, of the compressor mount, at the time of installation.

Please contact TransArctic with any issue arising from installation so we may better improve the product. If you have any reservations about the compressor mount integrity contact TransArctic immediately at 1-877-COLD-AIR.