

TOP VIEW

PARTS REMOVED FOR CLARITY.

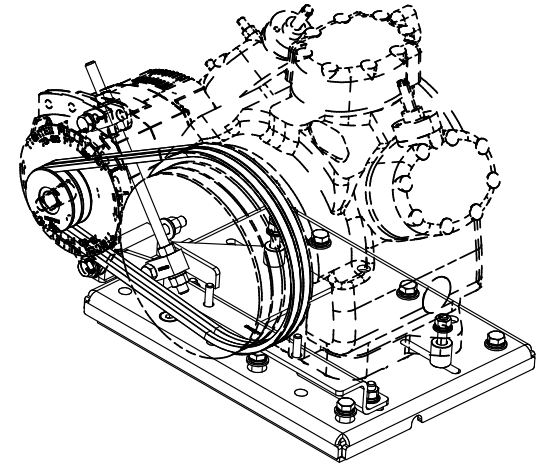

ISOMETRIC VIEW

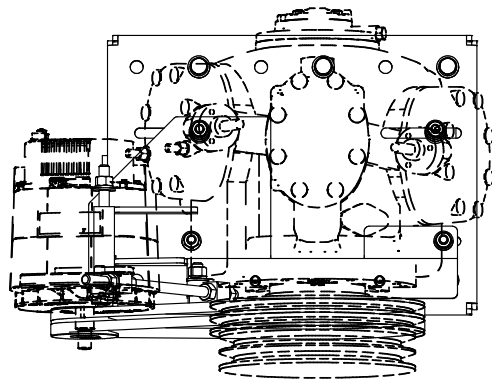
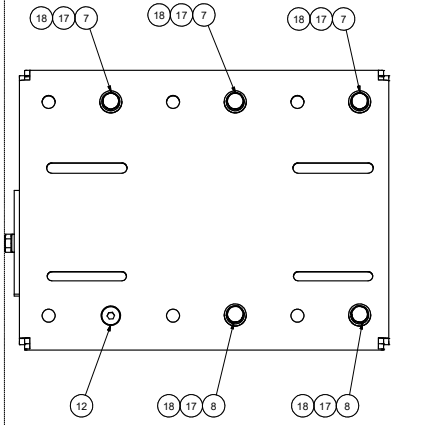
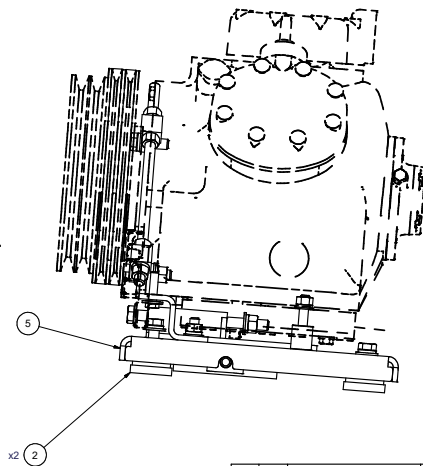
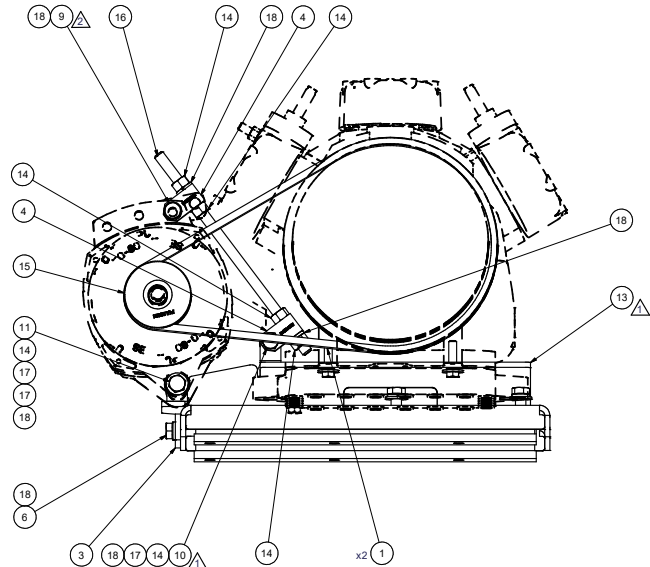

- NOTES:**
 1) USE SERVICABLE THREADLOCKER ON ALL FASTENERS TO ENGINE COMPONENTS AND TORQUE ALL BOLTS TO S.A.E. SPECIFICATIONS.
 2) SEE "TRANSARCTIC A/C COMPRESSOR MOUNT INSTALLATION DISCLAIMER".
 3) WEIGHT: 49.38 LBS.

ITEM	QTY	U/M	PART NUMBER	DESCRIPTION
18	11	EACH	WLQ08000	WASHER, LOCK, 1/2", 8, PLT
17	8	EACH	WFQ08000	WASHER, FLAT, 1/2", 8, PLT
16	1	EACH	TRD08120	THREADED, ROD, 1/2-13UNC x 12", 5 PLT
15	1	EACH	PUL03321	PULLEY, ALT, IDLER, 3.25", 2A
14	6	EACH	NTQ08000	NUT, HEX, 1/2-13UNC, 8, PLT
13	1	EACH	KBT84164	KIT, PLATFORM, O5G W/ ALT, '13
12	1	EACH	CSF08076	CAPSCREW, FH, 1/2-20UNF x .75", ALLOY, PLT
11	1	EACH	BTQ08653	BOLT, HEX, 1/2-13UNC x 6.50, 8, PLT
10	1	EACH	BTQ08200	BOLT, HEX, 1/2-13UNC x 2.00, 8, PLT
9	1	EACH	BTQ08150	BOLT, HEX, 1/2-13UNC x 1.50, 8, PLT
8	2	EACH	BTQ08126	BOLT, HEX, 1/2-20UNF x 1.25, 8, PLT
7	3	EACH	BTQ08101	BOLT, HEX, 1/2-20UNF x 1.00, 8, PLT
6	1	EACH	BTQ08653	BOLT, HEX, 1/2-13UNC x 6.50, 5, PLT, FT
5	1	EACH	BMZ00043	BKT, MAIN, BASE PL, '13
4	2	EACH	BMT10011	BKT, TENR, BLOCK, OFFSET, 3mm
3	1	EACH	BMN80025	BKT, BACK, PL, SLIDE, IC, RE300
2	2	EACH	BMN80008	VIBRATION ISOLATOR, BAR, 16.50 x 2 x 1.50
1	2	EACH	BEL11138	BELT, A GR, 1138mm (44.8")

BILL OF MATERIALS

TRANSARCTIC INC.

TITLE: **KIT, COMPRESSOR, 24V, O5G, '13**

DATE: 9/24/2013

SCALE: 1:4

SHEET 1 OF 1

REV	ECN	DESCRIPTION	DATE	BY
2		REMOVED BRACKET & FASTENERS	1/16/2013	JRR
1		REVISED KIB/ETK/TK	11/19/2013	JRR
0		RELEASED TO PRODUCTION	9/24/2013	JRR

UNSPECIFIED TOLERANCES: ALL DIMS IN INCHES
 ONE DECIMAL PLACE (.X) 1/16 1/32
 TWO DECIMAL PLACE (.XX) 1/64 1/128
 THREE DECIMAL PLACE (.XXX) .001 .005
 FRACTIONAL 1/16" 1/32" 3/64" 1/8"

THIRD ANGLE PROJECTION