

ISOMETRIC VIEW

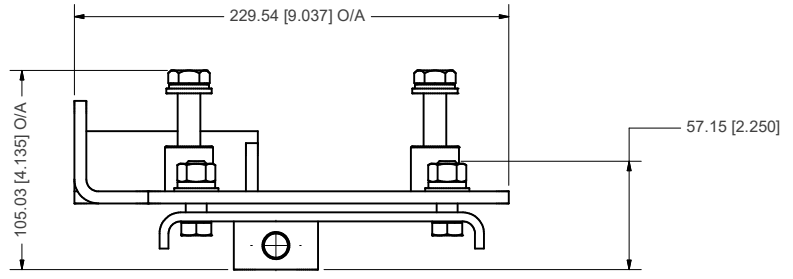

ITEM	QTY	U/M	PART NUMBER	DESCRIPTION
8	4	EACH	WLQ07000	WASHER, LOCK, 7/16", 8, PLT
7	4	EACH	WLA12000	WASHER, LOCK, 12mm, 8.8, PLT
6	4	EACH	WFP07000	WASHER, FLAT, 7/16", 2, PLT
5	4	EACH	WFA12000	WASHER, FLAT, 12mm, 8.8, PLT
4	4	EACH	NTP07000	NUT, HEX, 7/16-14UNC, 5, PLT
3	4	EACH	BTC12060	BOLT, HEX, 12 x 1.75 x 60mm, 10.9, PLT
2	1	EACH	BMN80031	BKT, MAIN, SLIDE, ASSY, 05K, IC, RE300
1	1	EACH	BMC83117	BKT, WELDM'T, 4xFCY W/ALT, T3RE, '13

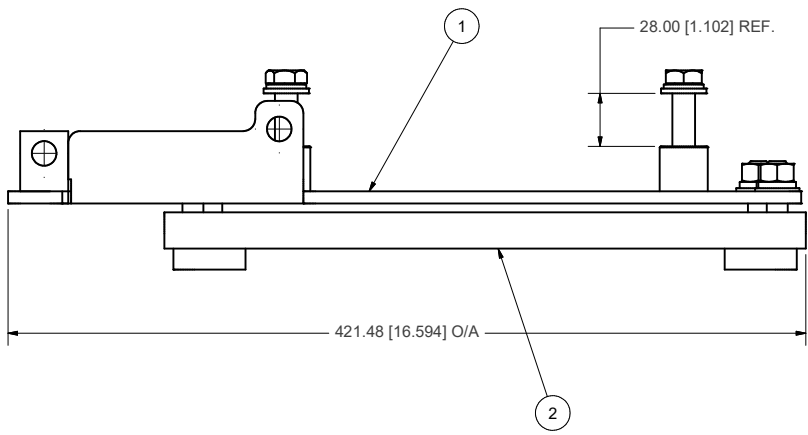

DRAWN	jrodriguez	7/12/2013
CHECKED	Val Jakowlew	7/12/2013
REV:	ECN:	DESCRIPTION:
0		RELEASED TO PRODUCTION: 7/24/2013 JRR
		DATE: BY: James Stewart 7/12/2013
MFG	Ron Ingram	7/12/2013
APPROVED	Dale Mason	7/12/2013

TITLE		
KIT, PLATFORM, 4xFCY W/ALT, '13		
SIZE	DWG NO	REV
C	KBT84064	0
SCALE	SHEET 1 OF 1	
1:2		

UNSPECIFIED TOLERANCES:		ALT. DIM.
ONE DECIMAL PLACE (X)	MM	(INCH)
TWO DECIMAL PLACE (XX)	0.50	[0.05]
THREE DECIMAL PLACE (XXX)	0.25	[0.10]
FRACTIONAL (1/32")	0.10	[0.05]
	ANGULAR	+/- .50°



- NOTES:
- 1) USE SERVICABLE THREADLOCKER ON ALL FASTENERS TO ENGINE COMPONENTS AND TORQUE **ALL** BOLTS TO S.A.E. SPECIFICATIONS.
 - 2) SEE "TRANSARCTIC A/C COMPRESSOR MOUNT INSTALLATION DISCLAIMER".
 - 3) WEIGHT: 18.22 LBS.