

Bill of Materials Listing

TransArctic Canada Inc.

5/29/2020
Page 1 of 1

Product Number		Description	Rev#	Date	Weight	Uof M	Yield
Line	Component Prod#	Description	Bin	Unit	Qty		
KMC62602		Mt Kit, ISB, C2, 2 TM-21, new '20	0	3/4/2008	69.91		0
5	PAC15110	Pack, Carton, 15" x 11" x 10", 51 ECT		each	1		
10	BEL61422	Belt, 6gr, 1422mm (56") (5060560)		each	1		
20	BMC67178	Bkt, Weldm't, ISB, 6.7L, C2, '20		each	1		
25	BMC67151	Bkt, Weldm't, ISB, 6.7L, Support Arm		each	1		
30	PUL67006	Pulley, Crank, ADD-ON, Cum, ISB, 6.7, P6		each	1		
40	PUL80076	Pulley, Idler, Backside, P8, 74d (89101)		each	1		
50	FSP59286	Spacer, Fan, Pulley, ISB, 28.6mm (1.13")	Alley	each	1		
55	FSP62905	Spacer, Fan, Pulley, ISB, 29.05mm(1.14")		each	1		
60	SLV17010	Sleeve, Pulley, 16.9o x 22.23mm x 10.32i		each	1		
70	SCD32010	Spacer, Col, Drl, 32.0mm x 25.4o x 10.3i		each	1		
80	TEN80005	Tenr, HD Spring, BackSide, CCW (89430)		each	1		
100	KBC62602	Bag Kit, Fasteners, KMC62602		each	1		

Bill of Materials Listing

TransArctic Canada Inc.

6/2/2020
Page 1 of 1

Product Number		Description	Rev#	Date	Weight	Uof M	Yield
Line	Component Prod#	Description	Bin	Unit	Qty		
KBC62602		Bag Kit, Fasteners, KMC62602	0	2/17/2016	4.04		0
5	BSD00001	Bolt, Stud, M10 x 1.5 x 80mm, 8.8, Plt		each	4		
10	BTC08100	Bolt, Hex, 8 x 1.25 x 100mm, 10.9, Plt		each	8		
20	BTC10035	Bolt, Hex, 10 x 1.5 x 35mm, 10.9, Plt,FT		each	3		
40	BTC10090	Bolt, Hex, 10 x 1.5 x 90mm, 10.9, Plt		each	2		
50	BTC10110	Bolt, Hex, 10 x 1.5 x 110mm, 10.9, Plt		each	6		
51	CSF08021	Capscrew, FH, 8 x 1.25 x 20mm, 10.9,Plt		each	2		
52	CSF10031	Capscrew, FH, 10 x 1.5 x 30mm, 10.9,Plt		each	2		
60	CSS12090	Capscrew, SH, 12 x 1.25 x 90mm, 12.9,BLK		each	6		
65	NTA10000	Nut, Hex, 10 x 1.5, 8.8, Plt		each	5		
70	WLA08000	Washer, Lock, 8mm, 8.8, Plt		each	8		
80	WLA10000	Washer, Lock, 10mm, 8.8, Plt		each	9		
90	WFA08000	Washer, Flat, 8mm, 8.8, Plt		each	8		
100	WFA10000	Washer, Flat, 10mm, 8.8, Plt		each	4		
105	WFA10002	Washer, Flat, 10mm, Hvy, 8.8, Plt		each	1		
110	WFS12002	Washer, Flat, Hdn, 12mm, Stl, BLK		each	6		

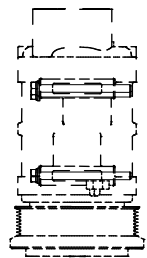

NOTE:
USE THE APPROPRIATE "FAN SPACER
& FASTENERS" SET-UP TO SUIT YOUR INSTALL.

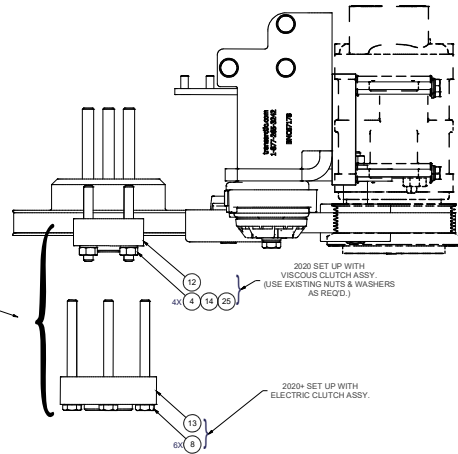

2020 SET UP WITH
VISCIOUS CLUTCH ASSY
(USE EXISTING NUTS & WASHERS
AS REQ'D.)

2020+ SET UP WITH
ELECTRIC CLUTCH ASSY.

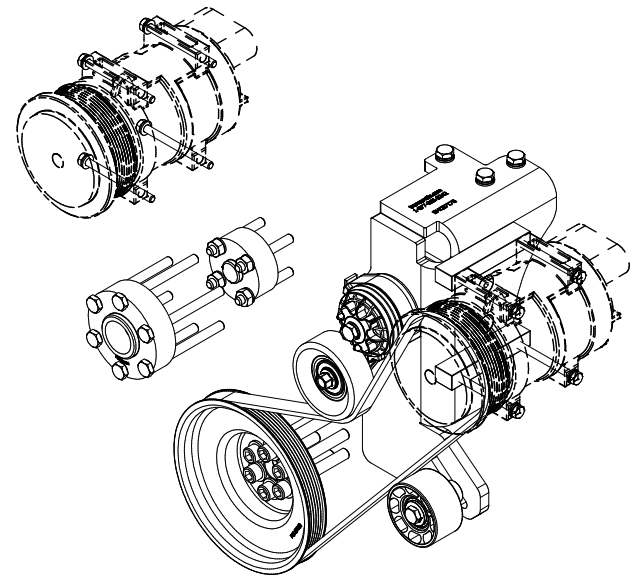

ISOMETRIC VIEW

BELT SITS IN FRONT 6 GROOVES
OF COMPRESSOR PULLEY

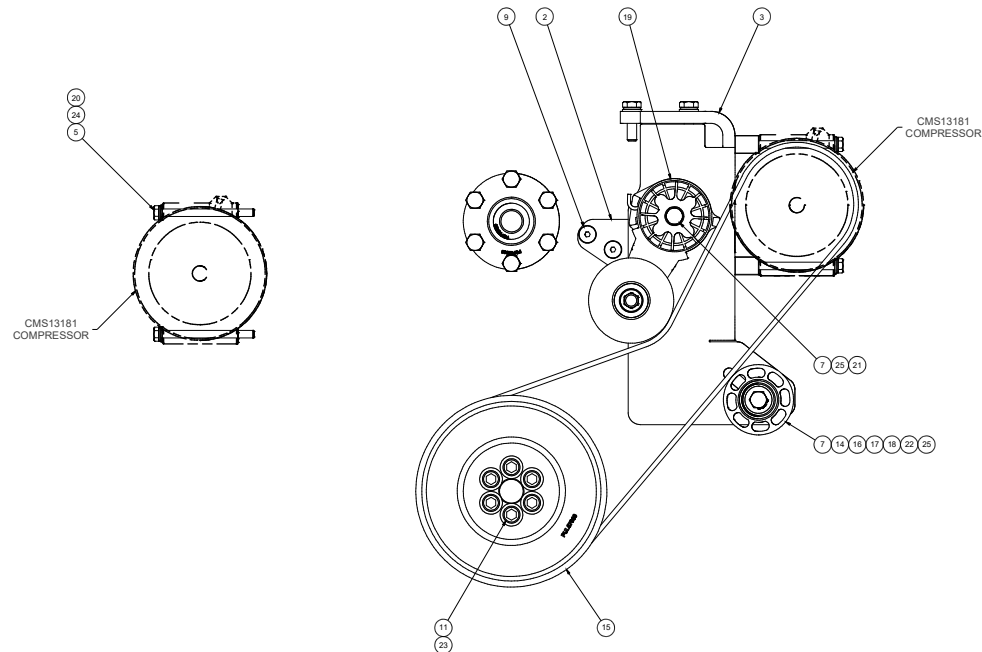

CMS13181
COMPRESSOR

CMS13181
COMPRESSOR

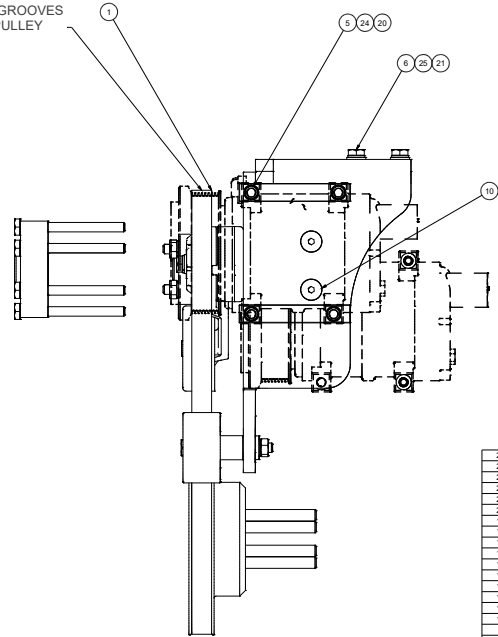

ITEM	QTY	U/M	PART NUMBER	DESCRIPTION
25	9	EACH	WLA10000	WASHER LOCK, 10mm, 8.8, PLT
24	8	EACH	WL45000	WASHER LOCK, 8mm, 8.8, PLT
23	6	EACH	WFS12002	WASHER FLAT, HDN, 12mm, STL, BLK
22	1	EACH	WFA10002	WASHER FLAT, 10mm, HVY, 8.8, PLT
21	4	EACH	WFA10000	WASHER FLAT, 10mm, 8.8, PLT
20	8	EACH	WFA8000	WASHER FLAT, 8mm, 8.8, PLT
19	1	EACH	TEN80005	TENR, HD SPRING, BACKSIDE, CCW (89430)
18	1	EACH	SLV17010	SLEEVE, PULLEY, 16.50 x 22.23mm x 13.26
17	1	EACH	SC030010	SPACER, COIL, DRL, 30.02mm x 25.40 x 10.3
16	1	EACH	PUL80076	PULLEY, IDLER, BACKSIDE, PB, 76D, 39W
15	1	EACH	PUL67006	PULLEY, CRANK, ADD-ON, CUM, ISB, 6.7, PB
14	2	EACH	NFA10000	NUT, HEX, 10 x 1.5, 8.8, PLT
13	1	EACH	FSP62905	SPACER, FAN, PULLEY, ISB, 29.05mm (1.14")
12	1	EACH	FSP62986	SPACER, FAN, PULLEY, ISC, 29.6mm (1.15")
11	6	EACH	CSF10090	CAPSCREW, SH, 10 x 1.25 x 90mm, 10.9, PLT
10	2	EACH	CSF10031	CAPSCREW, FH, 10 x 1.5 x 30mm, 10.9, PLT
9	2	EACH	CSF08021	CAPSCREW, FH, 8 x 1.25 x 10mm, 10.9, PLT
8	6	EACH	BTC18110	BOLT, HEX, 10 x 1.5 x 110mm, 10.9, PLT
7	2	EACH	BTC10090	BOLT, HEX, 10 x 1.5 x 90mm, 10.9, PLT
6	3	EACH	BTC10035	BOLT, HEX, 10 x 1.5 x 35mm, 10.9, PLT
5	8	EACH	BTC08100	BOLT, HEX, 8 x 1.25 x 100mm, 10.9, PLT
4	4	EACH	BSD00001	BOLT, STUD, M10 x 1.5 x 80mm, 8.8, PLT
3	1	EACH	BMCR7176	BKT, WELDMT, ISB, 6.7L, C2, 20
2	1	EACH	BMCR1151	BKT, WELDMT, ISB, 6.7L, SUPPORT ARM
1	1	EACH	BEL1422	Belt, Sp, 1397mm (56.0") (5060560)

DRAWN: jakowlew 8/12/2020
 CHECKED: Jose Rodriguez 8/12/2020
 DATE: 8/12/2020 BY: James Stewart
 TITLE: Mt Kit, ISB, C2, 2 TM-21, 20
 APPROVED: DAK Mason 8/12/2020
 DRAWING UNIT OF MEASURE: MM (INCH)
 SCALE: 1:1
 SHEET 1 OF 1

NOTES:
 1) USE SERVICEABLE THREADLOCKER ON ALL FASTENERS TO ENGINE COMPONENTS AND TORQUE ALL BOLTS TO S.A.E. SPECIFICATIONS.
 2) SEE "TRANSARCTIC A/C COMPRESSOR MOUNT INSTALLATION DISCLAIMER"

TRANSARCTIC INC.

Part No. **KMC62602**

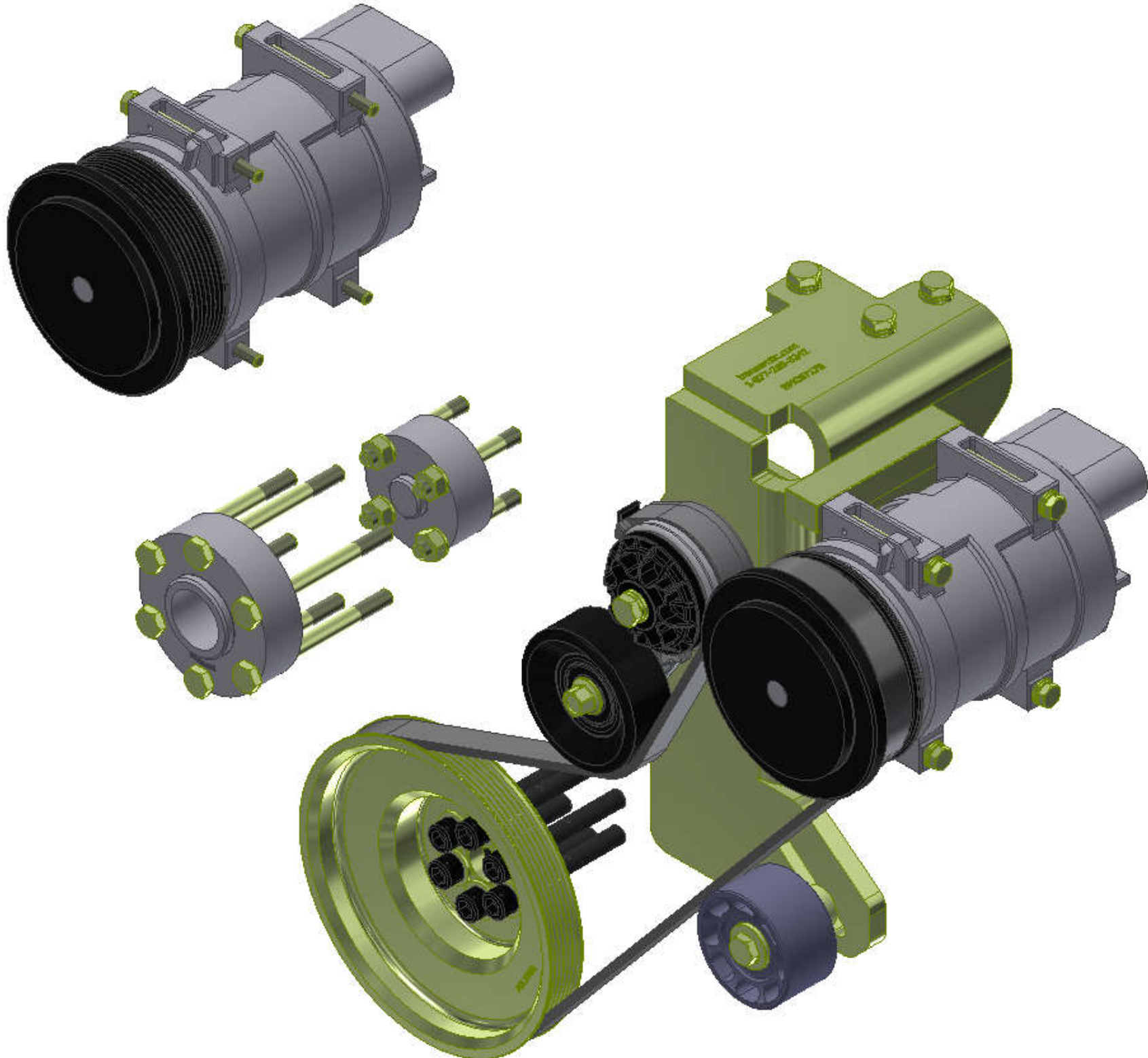

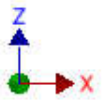
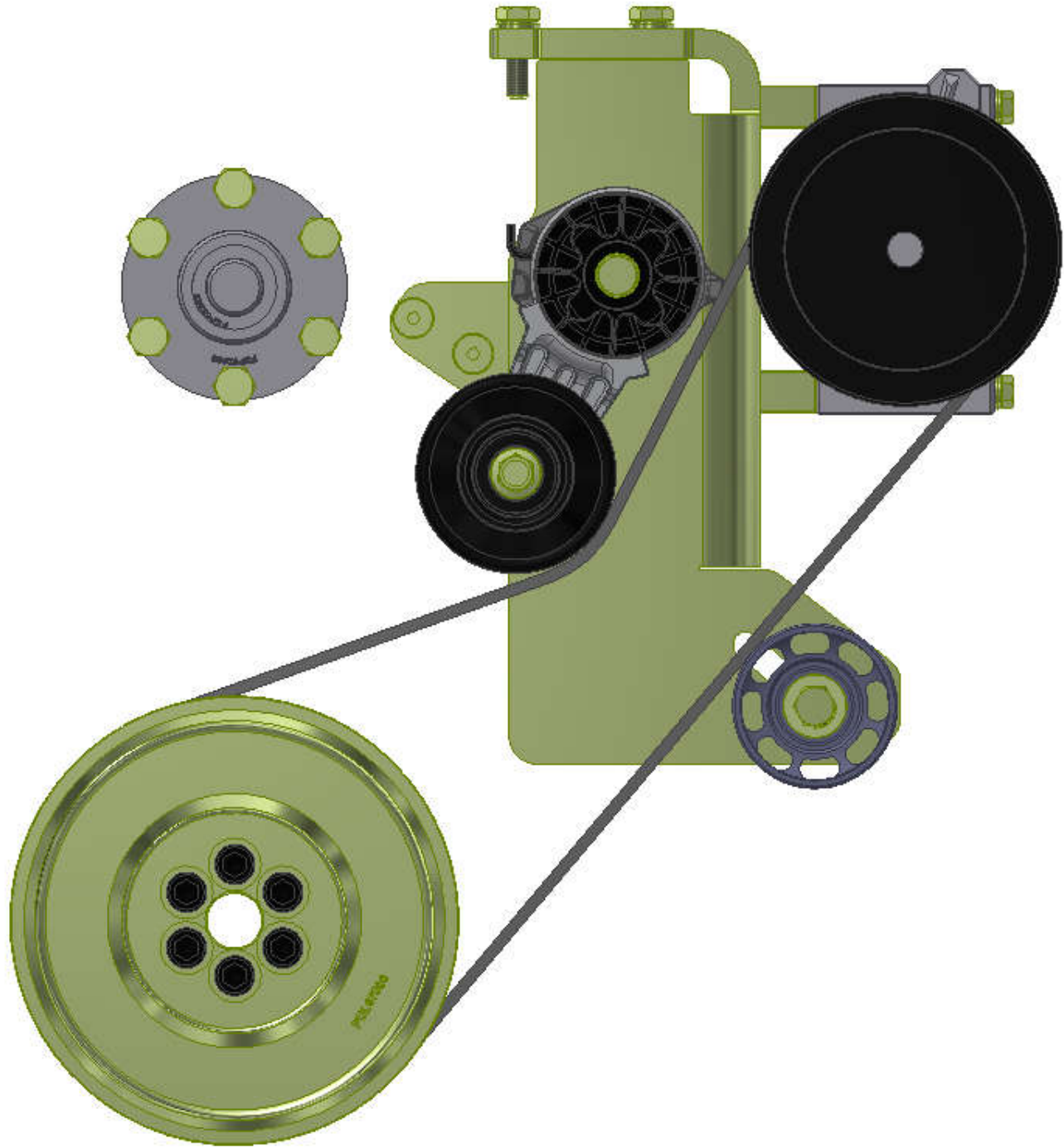
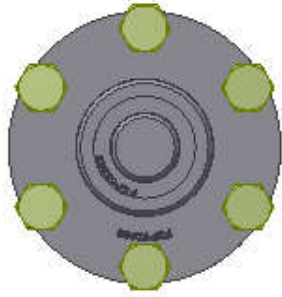
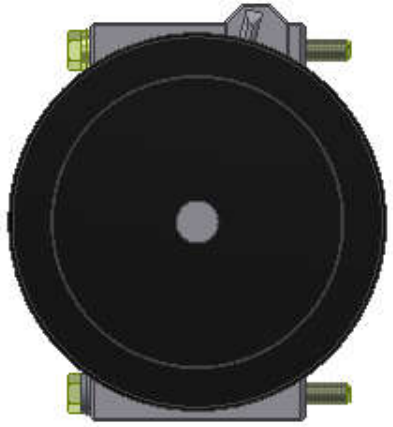

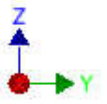
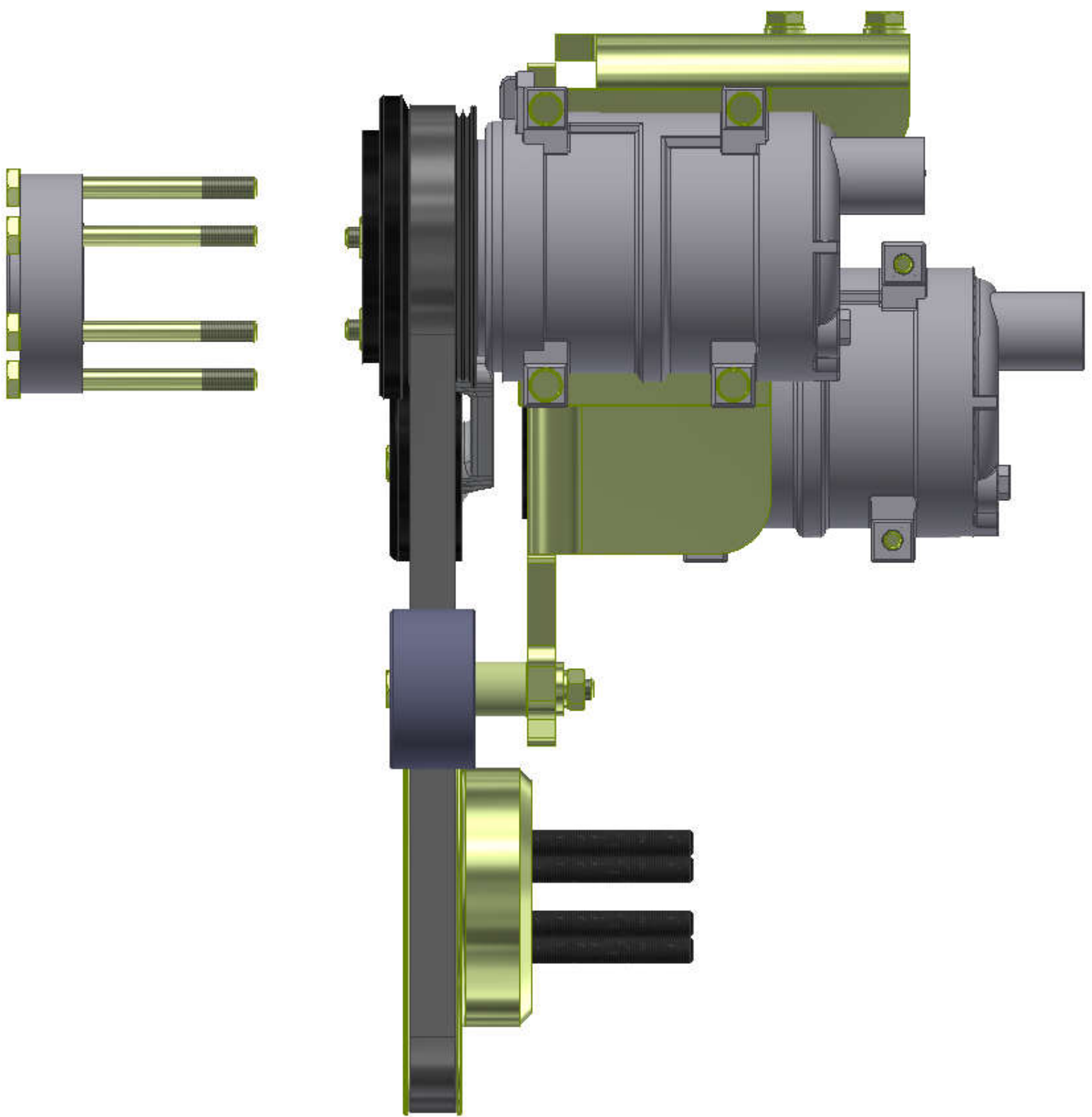

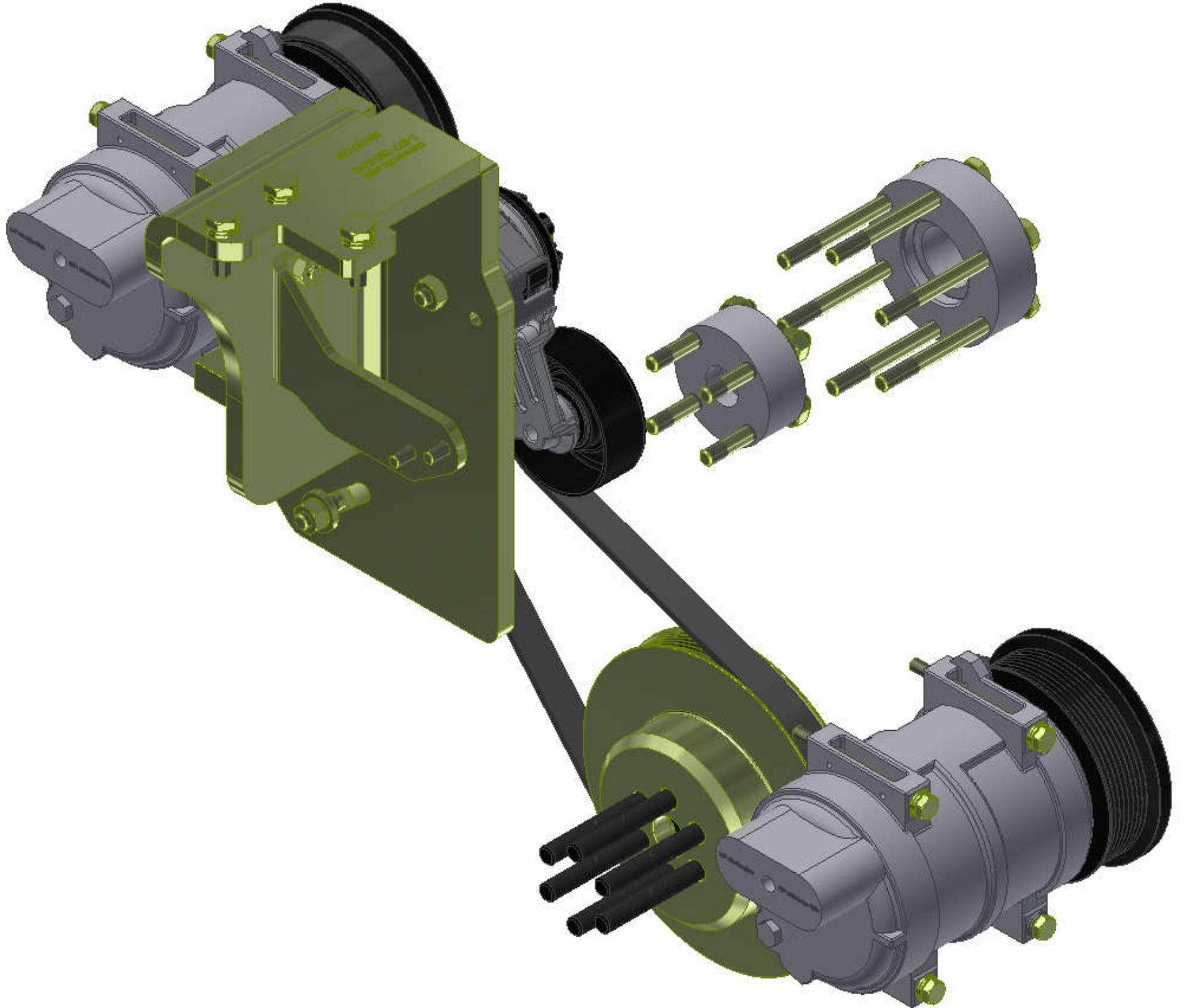

TransArctic A/C Compressor Mount Installation Disclaimer

All compressor mounts should be installed by qualified and trained personnel using proper tools and equipment in safe working conditions following industry standard guidelines for motor vehicle service and repair.

The installer of any compressor mount purchased from TransArctic must undertake all responsibility of issues arising from that compressor bracket being installed on any vehicle. As well as insure that a **proper and sufficient ground** is established between the compressors' clutches and the vehicle's engine. Mount functionality, operation and durability can all be compromised by an incompetent installation.

Due to the many different situations, parameters and application criteria, which are beyond the compressor mount manufacturer's control, TransArctic does not warrant design, durability, or operational functionality of any compressor mount improperly installed by another party.

With no implied guarantees it is the mount installer's strict responsibility to determine safety and functionality, of the compressor mount, at the time of installation.

Please contact TransArctic with any issue arising from installation so we may better improve the product. If you have any reservations about the compressor mount integrity contact TransArctic immediately at 1-877-COLD-AIR.

Mark OEM tensioner location

Install Kit

Check for Interferences

Check to ensure that the proper OEM tensioner orientation is maintained

Run engine with A/C system engaged for at least 10 minutes to run in belt

Check OEM tensioner orientation and adjust as required

Responsabilidad limitada de TransArctic en la instalación del soporte del compresor

Todos los soportes de los compresores deben ser instalados por personas calificadas y entrenadas, usando para ello los equipos y herramientas necesarios para esta labor en buenas condiciones y según las normas y guías para el servicio y/o reparación de motores de vehículos.

El instalador de los soportes comprados en TransArctic asume toda la responsabilidad de cualquier problema que surja en el soporte del compresor al vehículo; de igual manera es responsable que el cable a tierra sea conectado entre el embrague del compresor y el motor del vehículo.

Se advierte que el buen funcionamiento y la durabilidad del soporte pueden ser comprometidos por defectos en su instalación.

Debido a las diversas situaciones que se puedan presentar fuera del control del fabricante, TransArctic no garantiza el diseño, la durabilidad o el correcto funcionamiento de cualquier equipo inapropiadamente instalado por terceros.

Esta sobreentendido que el Instalador del montaje del compresor es estrictamente responsable de la seguridad y funcionamiento del equipo en el momento de la instalación.

Si tuviera algún problema o duda acerca de la instalación del soporte del compresor pongase en contacto inmediatamente con TransArctic al teléfono 1-877-COLD-AIR de modo que podamos mejorar nuestro producto.

Note la ubicación del medidor de tensión OEM

Instale el equipo

Controlar si hay interferencias.

Asegurese que el medidor de tensión mantenga la orientación justa.

Encienda el motor por lo menos 10 minutos con el sistema A/C enganchado para que la correa corra

Controle la orientación justa del medidor de tensión y ajuste a las condiciones requeridas del fabricante