

BANDED BELT OR MATCHED PAIR BELTS SUPPLIED BY OTHERS.

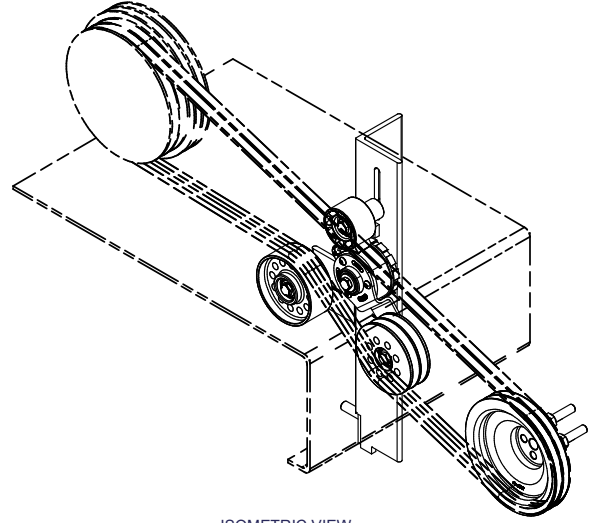

ISOMETRIC VIEW

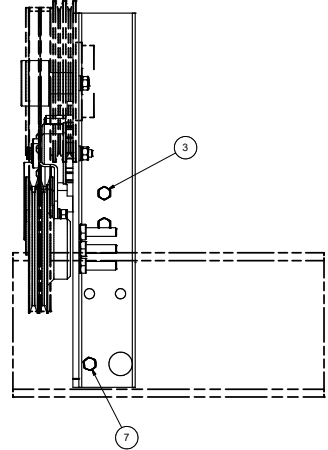

NOTES:
 1) USE SERVICABLE THREADLOCKER ON ALL FASTENERS TO ENGINE COMPONENTS AND TORQUE ALL BOLTS TO S.A.E. SPECIFICATIONS.
 2) SEE "TRANSARCTIC A/C COMPRESSOR MOUNT INSTALLATION DISCLAIMER".

ITEM	QTY	U/M	PART NUMBER	DESCRIPTION
19	6	EACH	WLA12000	WASHER, LOCK, 12mm, 8.8, PLT
18	6	EACH	WFA12000	WASHER, FLAT, 12mm, 8.8, PLT
17	1	EACH	TEN00003	TENR, SPRING, UN-DIRECT, 90d, 1/2 x 4.5"
16	3	EACH	SLV17012	SLEEVE, PULLEY, 18.90 x 22.23 mm x 12, 19l
15	1	EACH	SCD46012	SPACER, COL, DRL, 48mm x 34.90 x 12.3l
14	1	EACH	SCD42512	SPACER, COL, DRL, 42.5mm x 34.90 x 12.3l
13	1	EACH	SCD12912	SPACER, COL, DRL, 12.9 mm x 34.90 x 12.3l
12	1	EACH	PUL80074	PULLEY, IDLER, BACKSIDE, P8, 74D, 46.27W
11	1	EACH	PUL59001	PULLEY, CRANK, CUMMINS, ISB, 5.9, 2A
10	1	EACH	PJA05002	PULLEY, ASSY, IDLER, AB gr, 5" ALUM, PLT
9	1	EACH	PJA05000	PULLEY, ASSY, IDLER, B/S, 5", ALUM, PLT
8	6	EACH	NTA12000	NUT, HEX, 12 x 1.75, 8.8, PLT
7	1	EACH	BTO10250	BOLT, HEX, 5/8-11UNC, 2.50", 8, PLT
6	4	EACH	BTC14050	BOLT, HEX, 14 x 2 x 50mm, 10.9, PLT
5	3	EACH	BTC12100	BOLT, HEX, 12 x 1.75 x 100mm, 10.9, PLT
4	1	EACH	BTC12060	BOLT, HEX, 12 x 1.75 x 60mm, 10.9, PLT
3	2	EACH	BTC12040	BOLT, HEX, 12 x 1.75 x 40mm, 10.9, PLT
2	1	EACH	BMK70049	BKT, ANGLE, HOR, HDX, C7
1	1	EACH	BMK70044	BKT, ANGLE, VERT, WELDMT, HDX, C7

Bits of Material

TRANSARCTIC INC.

MT KIT, ISB, HDX ER, O5G, 2B, '07

SCALE: 1:1

SHEET 1 OF 1

REV	ECN	DESCRIPTION	DATE	BY
0		RELEASED TO PRODUCTION	7/6/2006	VAL
				James Stewart
				Val Jakowlew
				Dale Mason

UNSPECIFIED TOLERANCES:

ONE DECIMAL PLACE (X0.1) H9/k9

TWO DECIMAL PLACE (X0.05) H8/k7

THREE DECIMAL PLACE (X0.025) H7/k6

FRACTIONS, $1/16''$ H8/k7

THIRD ANGLE PROJECTION

DRAWING UNIT OF MEASURE: MM [INCH]