

REVISION	A	12/10/2014	Project	Use
DR SW	APP SW	608255	---	---
REVISION	B	6/11/2015	Project	Use
DR SW	APP SW	608716	---	---
REVISION	C	8/29/2015	Project	Use
DR SW	APP SW	608255	---	---
REVISION	D	1/4/2017	Project	Use
DR SW	APP SW	610302	---	---

NEW RELEASE
 ADDED GAS DEDICATED FUEL LEVEL CIRCUIT
 UPDATED PIN DESCRIPTION FOR C440-21 TO INCLUDE GAS.
 ADDED SHEET NUMBER FOR CIRCUIT CONTINUATION INFORMATION

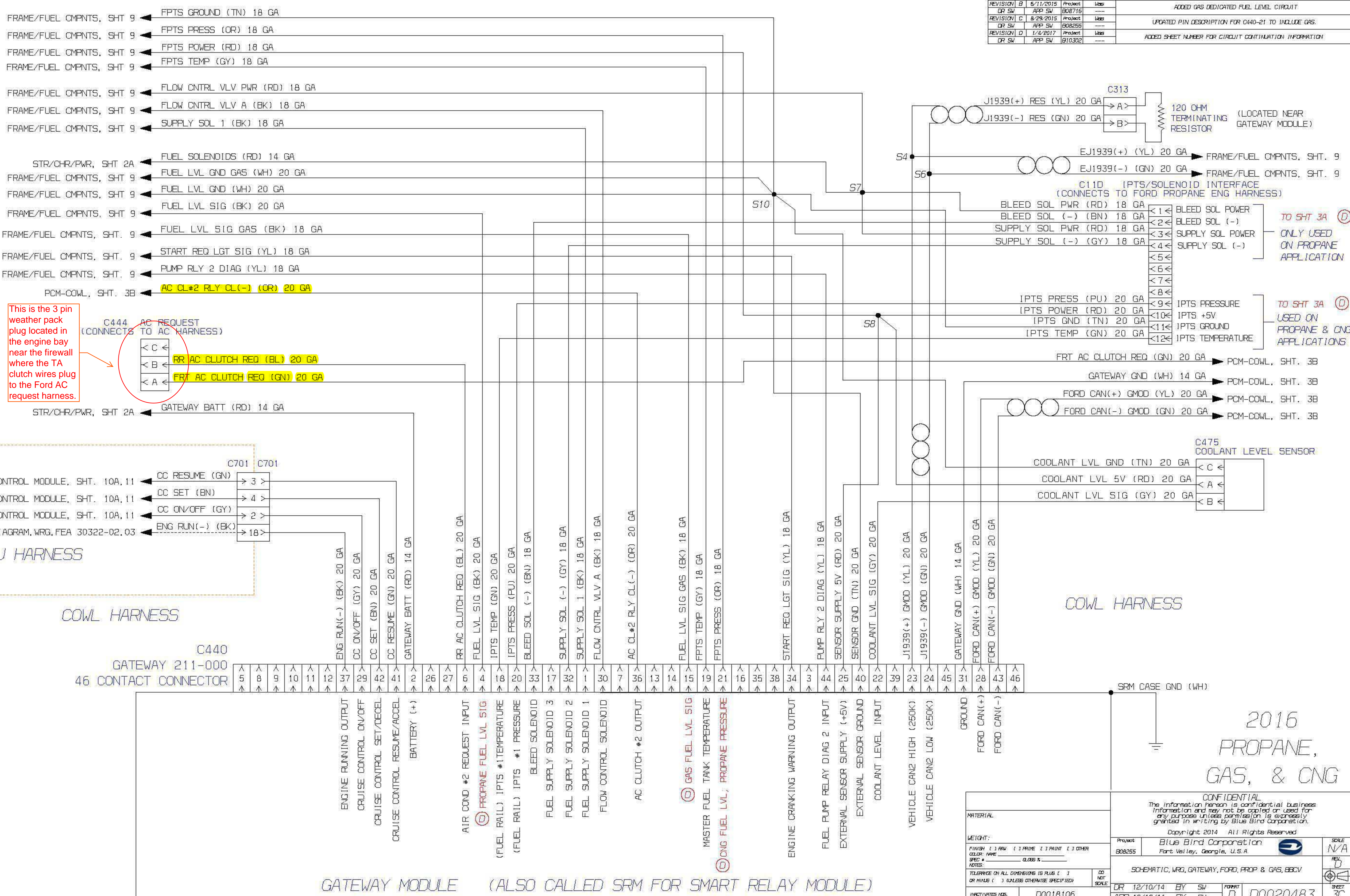

2016
 PROPANE,
 GAS, & CNG

MATERIAL:		CONFIDENTIAL The information herein is confidential business information and may not be copied or used for any purpose unless permission is expressly granted in writing by Blue Bird Corporation.	
WEIGHT:		Copyright 2014 All Rights Reserved	
FINISH () RAW () PRIME () PAINT () OTHER	Project	Blue Bird Corporation	SCALE
COLOR NAME	608255	Fort Valley, Georgia, U.S.A.	N/A
SPR #	---	---	REV
NOTES:	---	---	B
TOLEANCE ON ALL DIMENSIONS IS PLUS () OR MINUS () UNLESS OTHERWISE SPECIFIED	DO NOT SCALE	SCHMATIC, WRG, GATEWAY, FORD, PROP & GAS, BBCV	---
INACT/VATES NOS.	D0018106	DR 12/10/14 BY SW	FORMIT D D0020483
		APP 12/10/14 BY SW	SHEET 3C

GATEWAY MODULE (ALSO CALLED SRM FOR SMART RELAY MODULE)

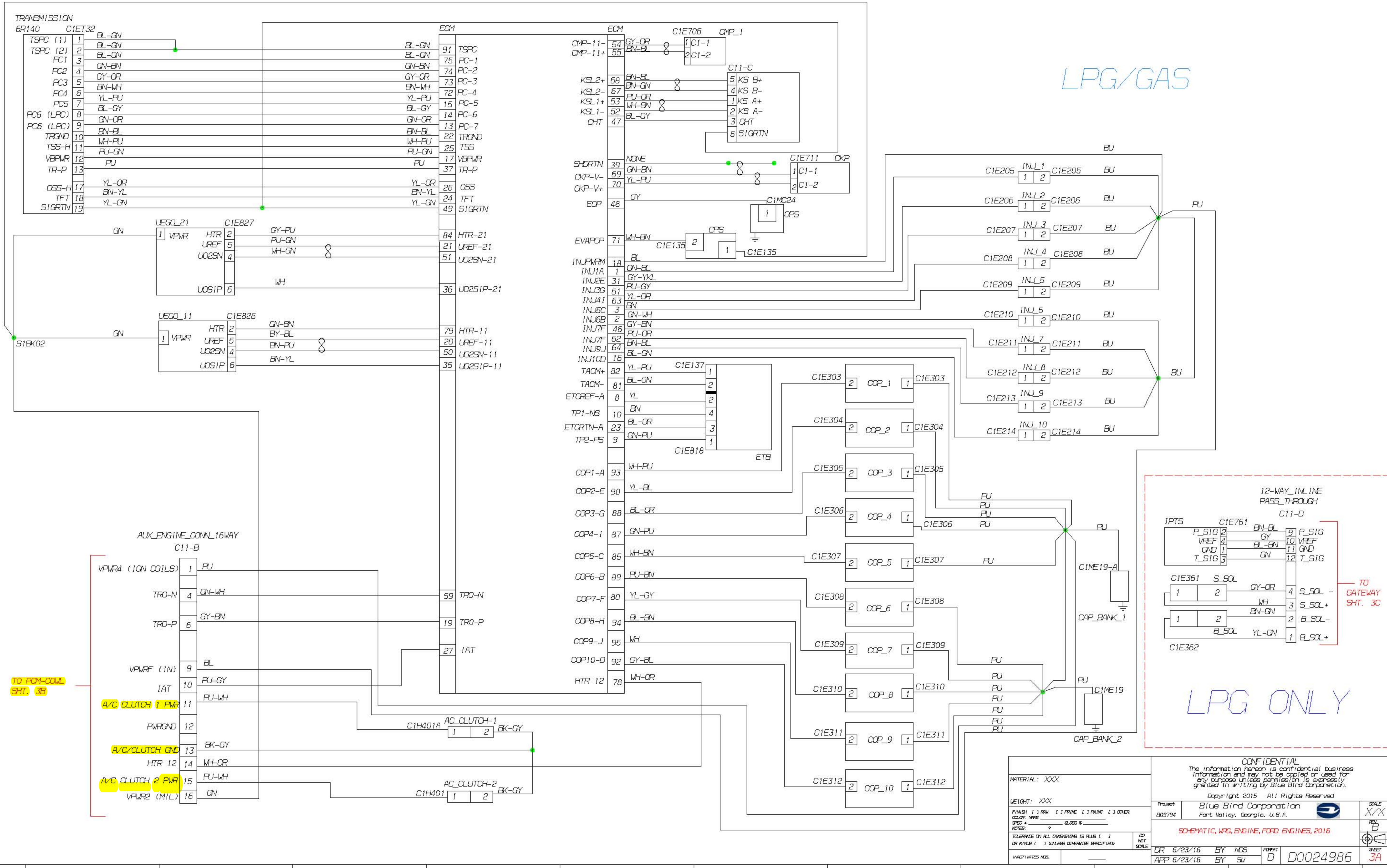

LPG/GAS

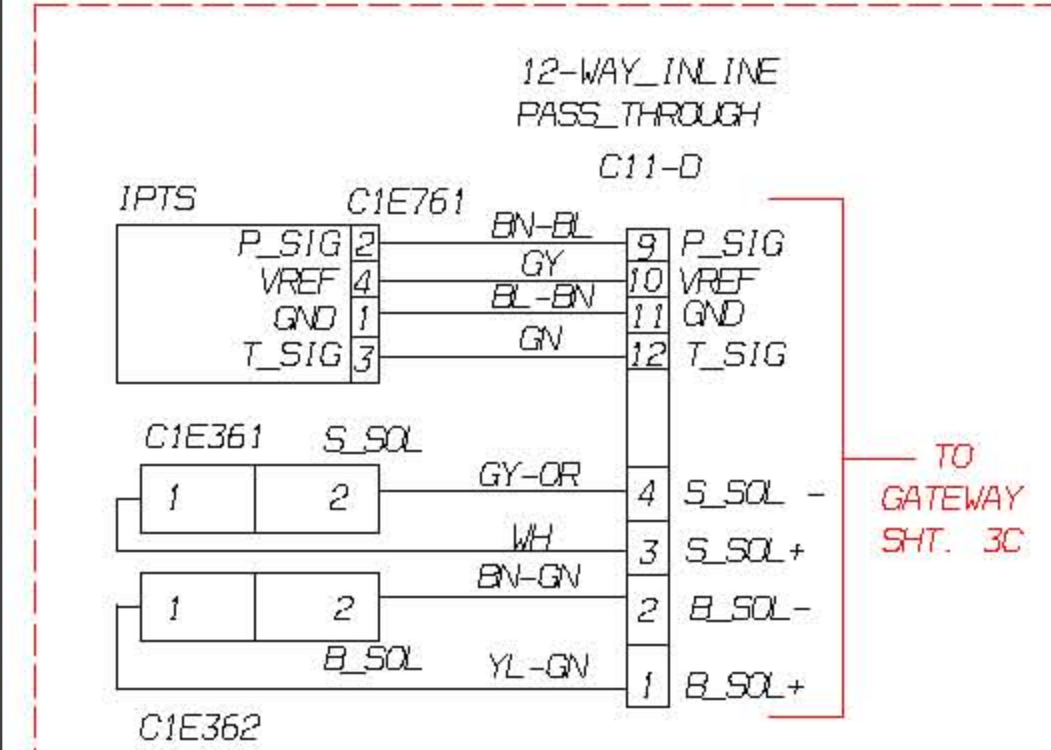

LPG ONLY

TO PCM-COM SHT. 3B

A/C CLUTCH 1 PWR
A/C/CLUTCH GND
A/C CLUTCH 2 PWR
VPWR2 (MIL)

MATERIAL: XXX		CONFIDENTIAL The information herein is confidential business information and may not be copied or used for any purpose unless permission is expressly granted in writing by Blue Bird Corporation.	
WEIGHT: XXX		Copyright 2015 All Rights Reserved	
FINISH () RAW () PRIME () PAINT () OTHER		Project B09794 Blue Bird Corporation Fort Valley, Georgia, U.S.A.	
COLOR: NAME		SCALE XXX	
SPECS: QLOS %		REV B	
NOTES: ?		SCHEMATIC, WAG, ENGINE, FORD ENGINES, 2016	
TOLERANCE ON ALL DIMENSIONS IS PLUS () OR MINUS () UNLESS OTHERWISE SPECIFIED		DR 6/23/16 BY NCS APP 6/23/16 BY SW	
INACT/VATES NOS.		FORMIT D D0024986 SCALE 3A	