

Bill of Materials Listing

TransArctic Canada Inc.

10/9/2019
Page 1 of 1

Product Number	Description	Rev#	Date	Weight	Uof M	Yield
Line	Component Prod#	Bin	Unit	Qty		
KMC62653	Mt Kit, ISB, T3/D3FE/VIS,2 TM-21,'10-'13	4	5/14/2010	17.05		0
5	PAC15110		Pack, Carton, 15" x 11" x 10", 51 ECT	each	1	
10	BEL61107		Belt, 6gr, 1107mm (43.6") (5060436)	each	1	
20	BMC67050		Bkt, Main, Weldmt, ISB, D3FE, 2010	each	1	
30	BMC67053		Bkt, Cradle, BTM, 87mm, ISB, D3FE, 2010	each	1	
40	BMC67159		Bkt,S/Bar,Weldmt,ISB,D3/T3RE/FE/BBCV,10+	each	1	
50	BMN80038		Bkt, Rad Hose, PMax DT, CE300	each	1	
60	BMS16022	Alley	Bkt, TM-16 Spacer Plate, .38"	each	2	
70	BMZ00028		Bkt, Universal Hose & Cable	each	4	
80	CLP20016		Clamp, "P" type, #16, 1/2"w, 1", PC	each	1	
90	CLP20020		Clamp, "P" type, #20, 1/2"w, 1 1/4", PC	each	2	
100	CLP20032		Clamp, "P" type, #32, 1/2"w, 2", PC	each	1	
110	HOA01002		Hose, Air, 1" ID	feet	5.00	
120	TEN80005		Tenr, HD Spring, BackSide, CCW (89430)	each	1	
130	KBC62653		Bag Kt, Fast'ns, KMC62653/KMC62677/2077	each	1	
140	21047		Cable Tie, 15", UV Resistant, Black	each	2	

NOTES:

- 1) CHECK OEM TENSIONER FOR PROPER ORIENTATION.
USE (2) BMS16022 (SPACERS) AS REQ'D, TO GET THE OEM TENSIONER TO IT'S ORIGINAL "CLOCKED" POSITION.
- 2) MAY-6 & 16-13_Added (5ft) HOA01002 & use (2) existing C/T clamps to make this kit work on a 2013 emissions engine.
- 3) NOTE:
When kits are for a FE 2010 & 2013 & 2016 emission installs.
Please add:
(2) CLP20020 p-clamp.

Bill of Materials Listing

TransArctic Canada Inc.

10/9/2019
Page 1 of 1

Product Number		Description	Rev#	Date	Weight	Uof M	Yield
Line	Component Prod#	Description	Bin	Unit	Qty		
KBC62653		Bag Kt, Fast'ns, KMC62653/KMC62677/2077		5/14/2010	1.43		0
10	BTC10080	Bolt, Hex, 10 x 1.5 x 80mm, 10.9, Plt,FT		each	1		
20	BTC10040	Bolt, Hex, 10 x 1.5 x 40mm, 10.9, Plt,FT		each	2		
30	BTC10030	Bolt, Hex, 10 x 1.5 x 30mm, 10.9, Plt		each	1		
40	BTC08100	Bolt, Hex, 8 x 1.25 x 100mm, 10.9, Plt		each	4		
45	BTC08110	Bolt, Hex, 8 x 1.25 x 110mm, 10.9, Plt		each	4		
47	BTC08045	Bolt, Hex, 8 x 1.25 x 45mm, 10.9, Plt		each	1		
65	BTC08025	Bolt, Hex, 8 x 1.25 x 25mm, 10.9, Plt		each	1		
72	BTP04100	Bolt, Hex, 1/4-20unc, 1", 5, Plt		each	1		
74	NTA08000	Nut, Hex, 8 x 1.25, 8.8, Plt		each	1		
76	NTP04000	Nut, Hex, 1/4-20unc, 5, Plt		each	1		
80	WFA10000	Washer, Flat, 10mm, 8.8, Plt		each	4		
90	WFA08000	Washer, Flat, 8mm, 8.8, Plt		each	10		
95	WFP04000	Washer, Flat, 1/4", 5, Plt		each	1		
100	WLA10000	Washer, Lock, 10mm, 8.8, Plt		each	4		
110	WLA08000	Washer, Lock, 8mm, 8.8, Plt		each	10		
120	WLP04000	Washer, Lock, 1/4", 5, Plt		each	1		

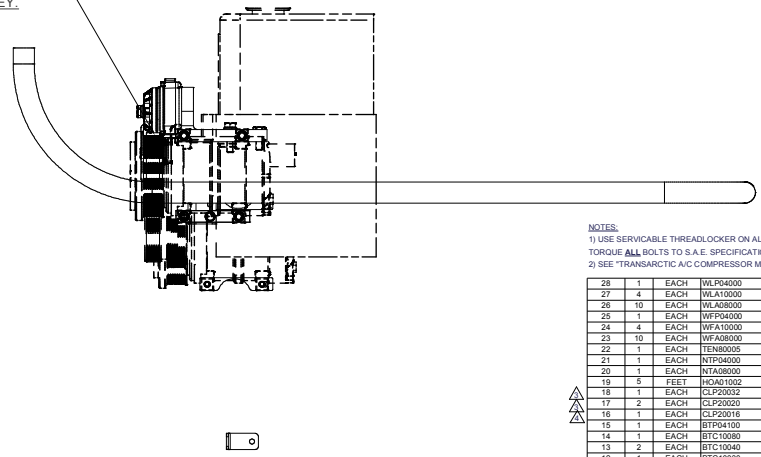
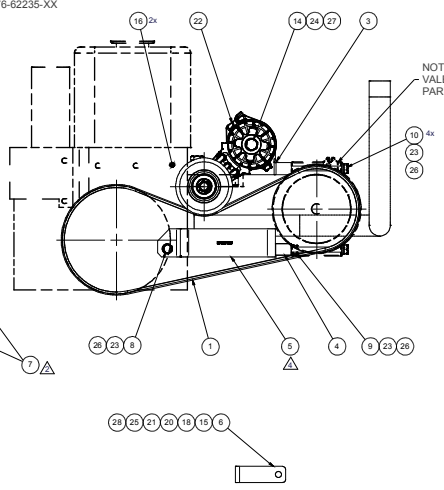
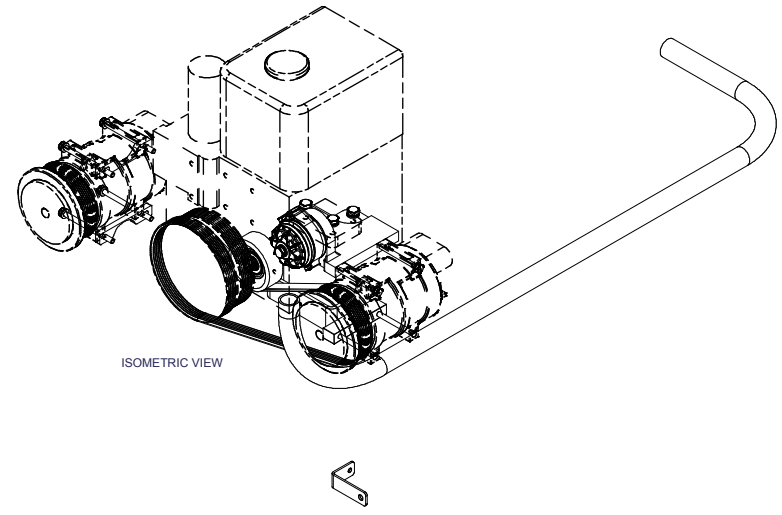
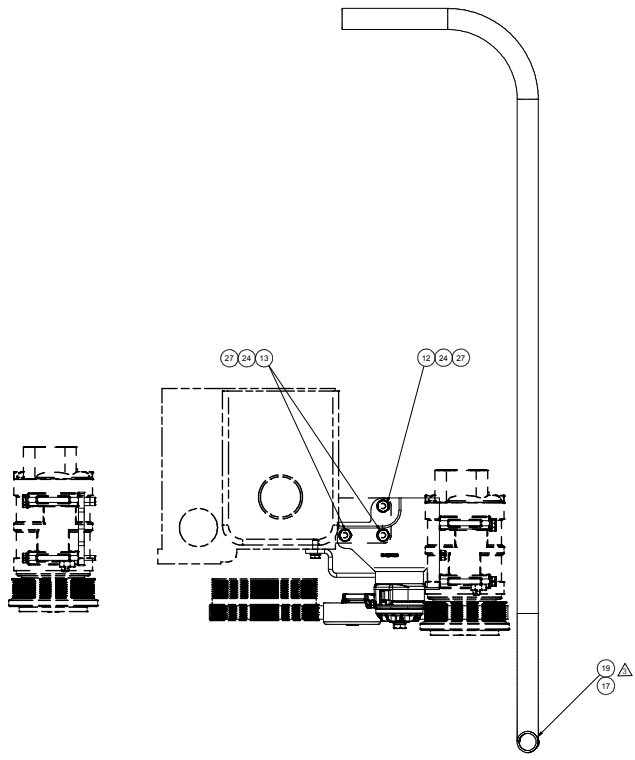

NOTE:
- ON A SINGLE MOUNT INSTALL.
- DELETE (4) OF EACH OF THESE ITEM#s, 11, 22, 25.
AND DELETE (2) OF ITEM #6.
- THESE PARTS ARE NOT REQ'D IN THESE CASES.

NOTE:
INSTALL THE 6 GR. BELT ON THE
MIDDLE 6 GROOVES OF THE 8 GR.
COMPRESSOR PULLEY.

NOTES:
1) USE SERVICABLE THREADLOCKER ON ALL FASTENERS TO ENGINE COMPONENTS AND TORQUE ALL BOLTS TO S.A.E. SPECIFICATIONS.
2) SEE "TRANSARCTIC A/C COMPRESSOR MOUNT INSTALLATION DISCLAIMER".

ITEM	QTY	UOM	PART NUMBER	DESCRIPTION
28	1	EACH	WLR04000	WASHER LOCK, 1/4", 5, PLT
27	4	EACH	WLA10500	WASHER LOCK, 10mm, 8.8, PLT
26	10	EACH	WLA08000	WASHER LOCK, 8mm, 8.8, PLT
25	1	EACH	WFP04000	WASHER FLAT, 1/4", 5, PLT
24	4	EACH	WFA10500	WASHER FLAT, 10mm, 8.8, PLT
23	10	EACH	WFA08000	WASHER FLAT, 8mm, 8.8, PLT
22	1	EACH	TEM80005	TENR. HD SPRNGS. BACKSIDE. CCW (88430)
21	1	EACH	NTP04000	NUT, HEX, 3/4, 2.5, 8.8, PLT
20	1	EACH	NTA08000	NUT, HEX, 8, 1.25, 8.8, PLT
19	5	FEET	HOA01002	Hose, Air, 1" ID
18	1	EACH	CLP2002	CLAMP, "P" TYPE, #12, 1/2"W, 2" PC
17	2	EACH	CLP20020	CLAMP, "P" TYPE, #20, 1/2"W, 1 1/4" PC
16	1	EACH	CLP20016	CLAMP, "P" TYPE, #16, 1/2"W, 1" PC
15	1	EACH	BTF04100	BOLT, HEX, 1/4-20UNC, 1" S, PLT
14	1	EACH	BTC10090	BOLT, HEX, 10 x 1.5 x 80mm, 10.9, PLT
13	2	EACH	BTC10040	BOLT, HEX, 10 x 1.5 x 40mm, 10.9, PLT
12	1	EACH	BTC10030	BOLT, HEX, 10 x 1.5 x 30mm, 10.9, PLT
11	4	EACH	BTC08110	BOLT, HEX, 8 x 1.25 x 110mm, 10.9, PLT
10	4	EACH	BTC08100	BOLT, HEX, 8 x 1.25 x 100mm, 10.9, PLT
9	1	EACH	BTC08045	BOLT, HEX, 8 x 1.25 x 45mm, 10.9, PLT
8	1	EACH	BTC08025	BOLT, HEX, 8 x 1.25 x 25mm, 10.9, PLT
7	2	EACH	BMS16022	BKT, TM-16, SPACER PLATE
6	1	EACH	BMN80038	BKT, RAD HOSE, P/MAX DT, CE300
5	1	EACH	BMC37150	BKT, SSB, WELDMT, ISB, D3FE, 2010
4	1	EACH	BMC37053	BKT, CRADLE, BTM, 87mm, ISB, D3FE, 2010
3	1	EACH	BMC37050	BKT, MAIN WELDMT, ISB, D3FE, 2010
2	4	EACH	BMC20028	BKT, UNIVERSAL HOSE & CABLE
1	1	EACH	BE161107	BELT, 6 gr, 1107mm (43.6")

NOTE:
VALEO COMPRESSOR
PART#: 103-67260

OEM POSITION

NOTE:
VALEO COMPRESSOR
PART#: 103-67260

TRANSARCTIC INC. logo and company information.

DATE: 5/18/2010
DRAWN: jkrowlew
CHECKED: jkrowlew
DESIGNED: jkrowlew
REV: 1

REV ECN: DESCRIPTION: DATE: BY: James Stewart 5/18/2010

APPROVED: Ron Ingram 5/18/2010
DATE: Dale Mason 5/18/2010

MT KIT, ISB, 6.7L, D3FE, 2-TM-21, '10-'13

REV 4

USE THESE (2) SPACERS TO GET THE OEM TENSIONER TO IT'S ORIGINAL "CLOCKED" POSITION. CHECK OEM TENSIONER FOR PROPER ORIENTATION.

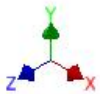
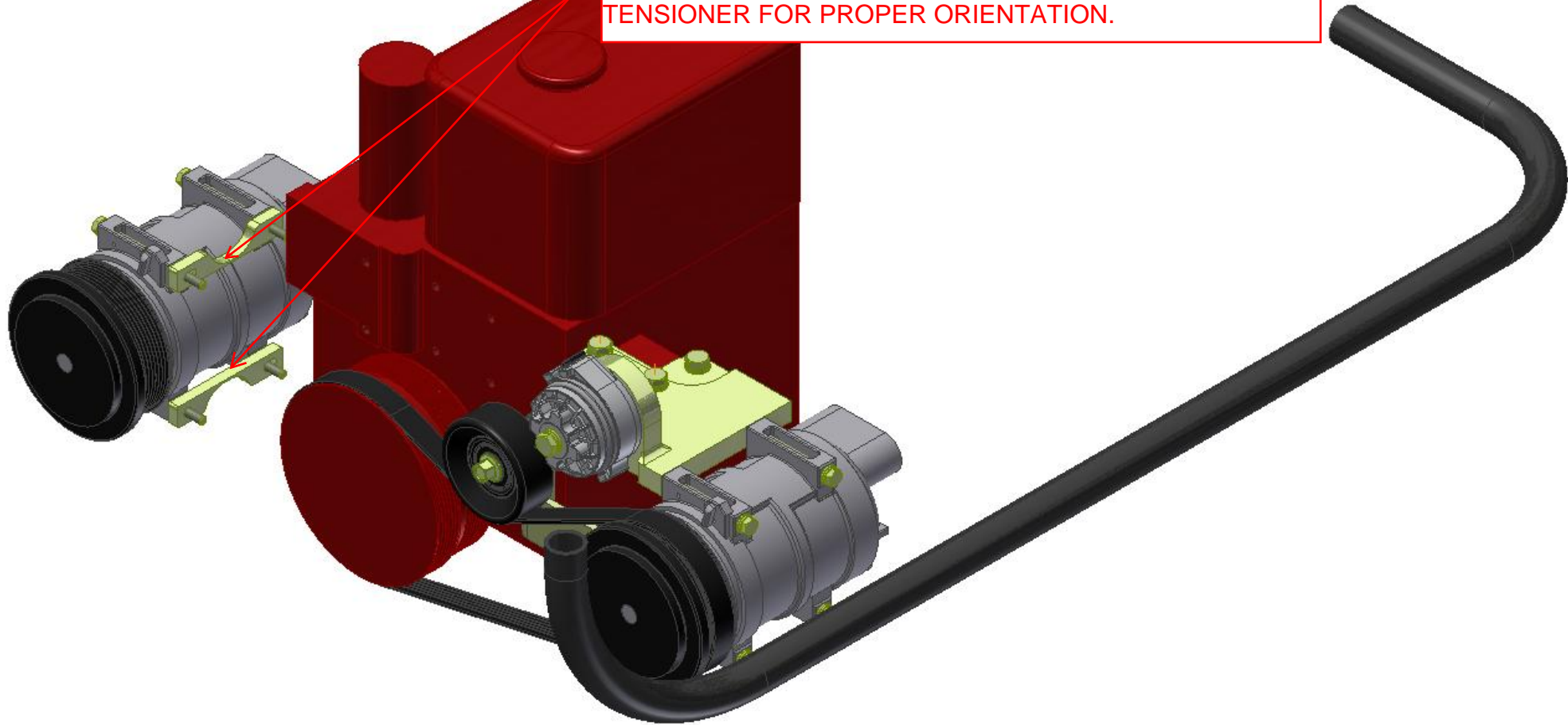

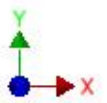
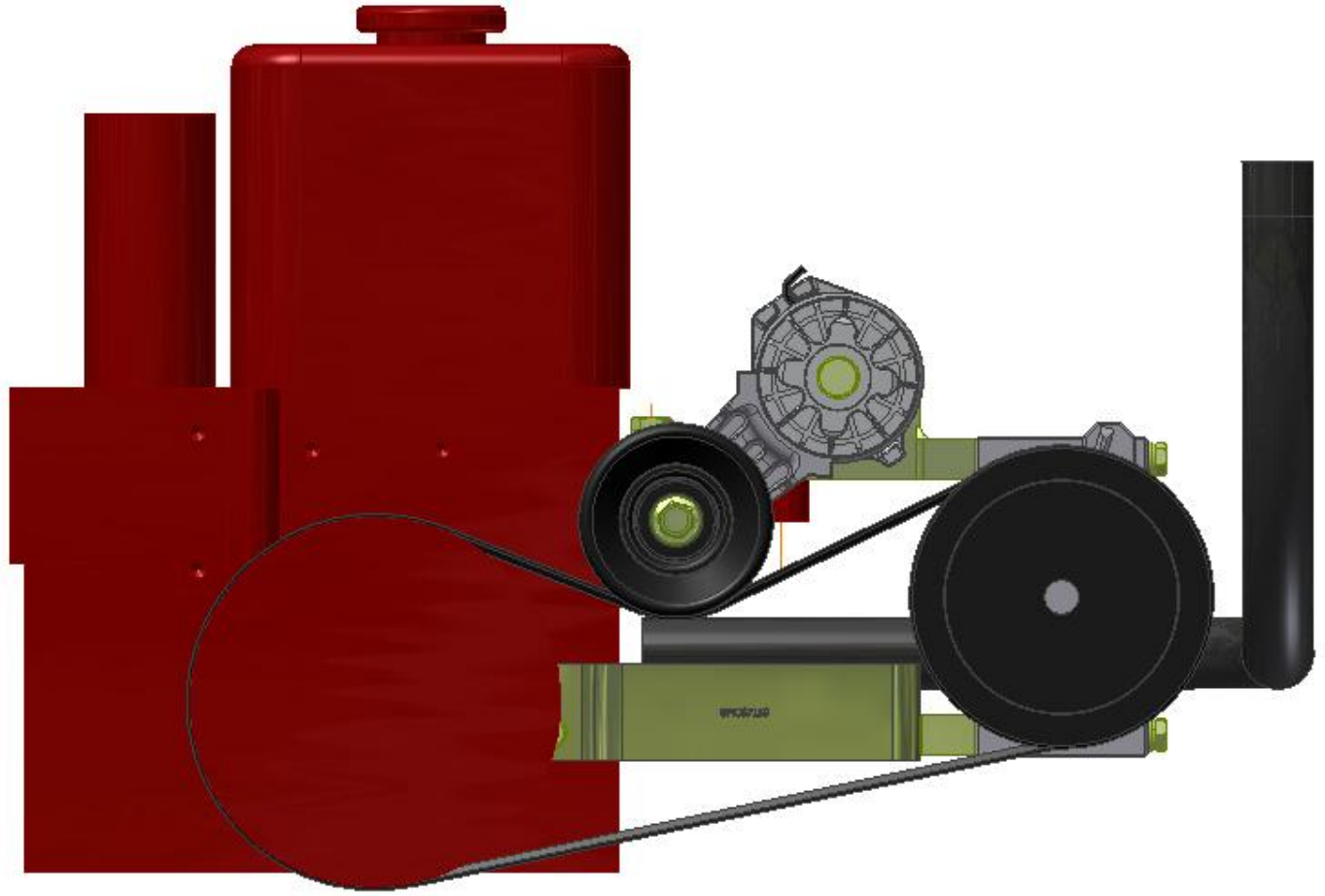
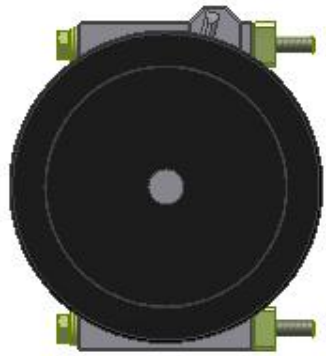

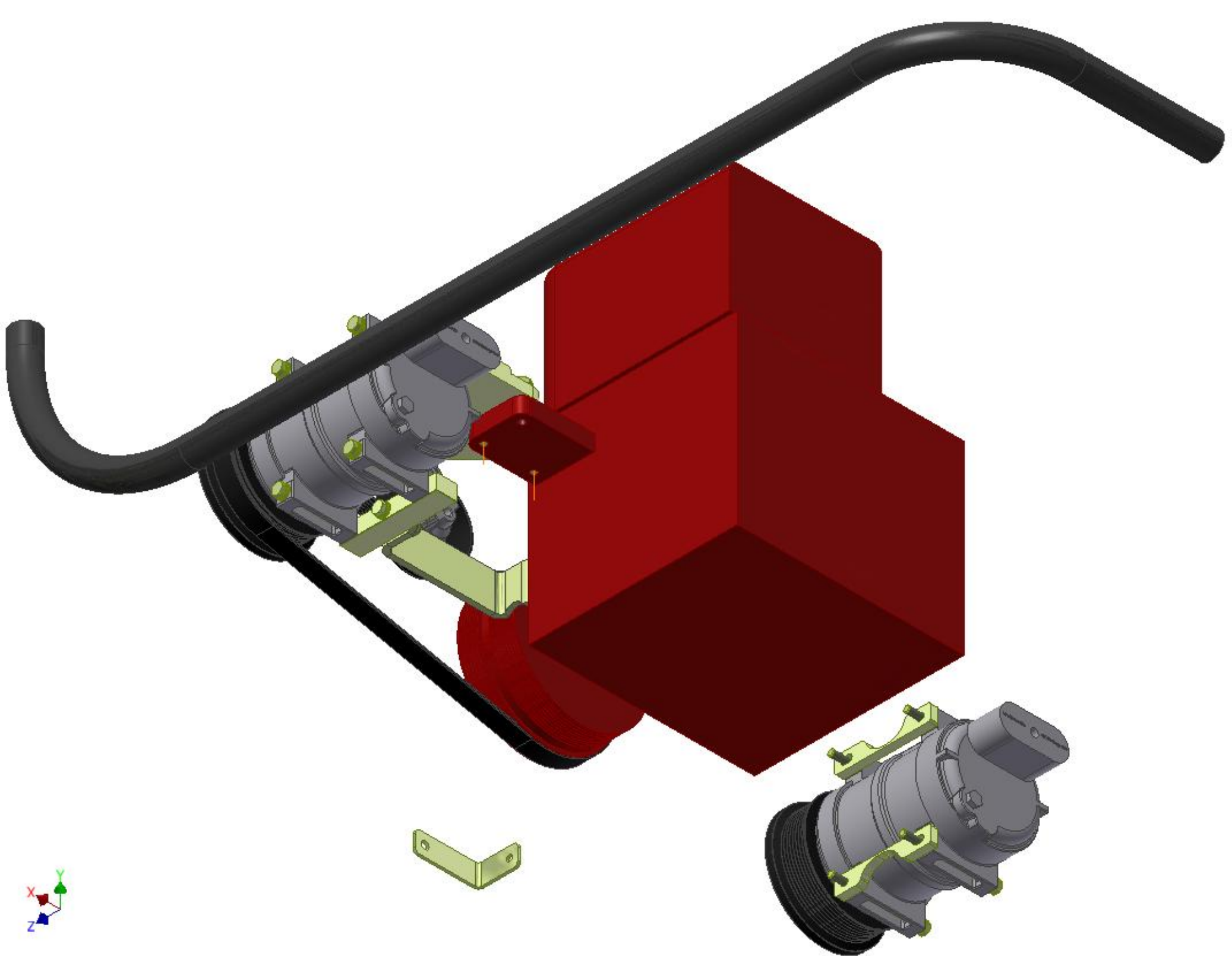

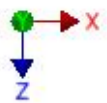
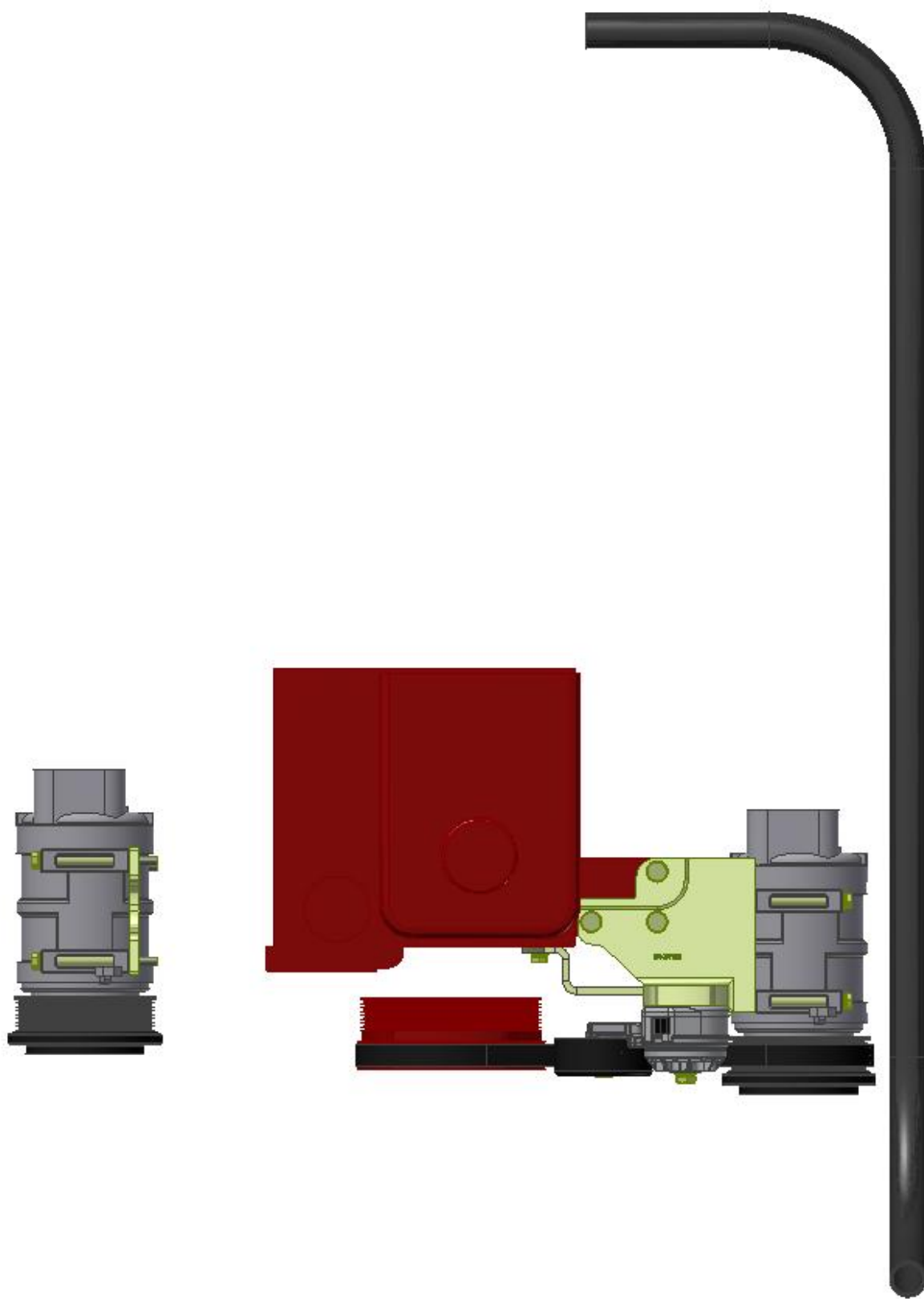

INSTALL (1) #16 P/CLAMP TO SECURE THE LOOM HARNESS.

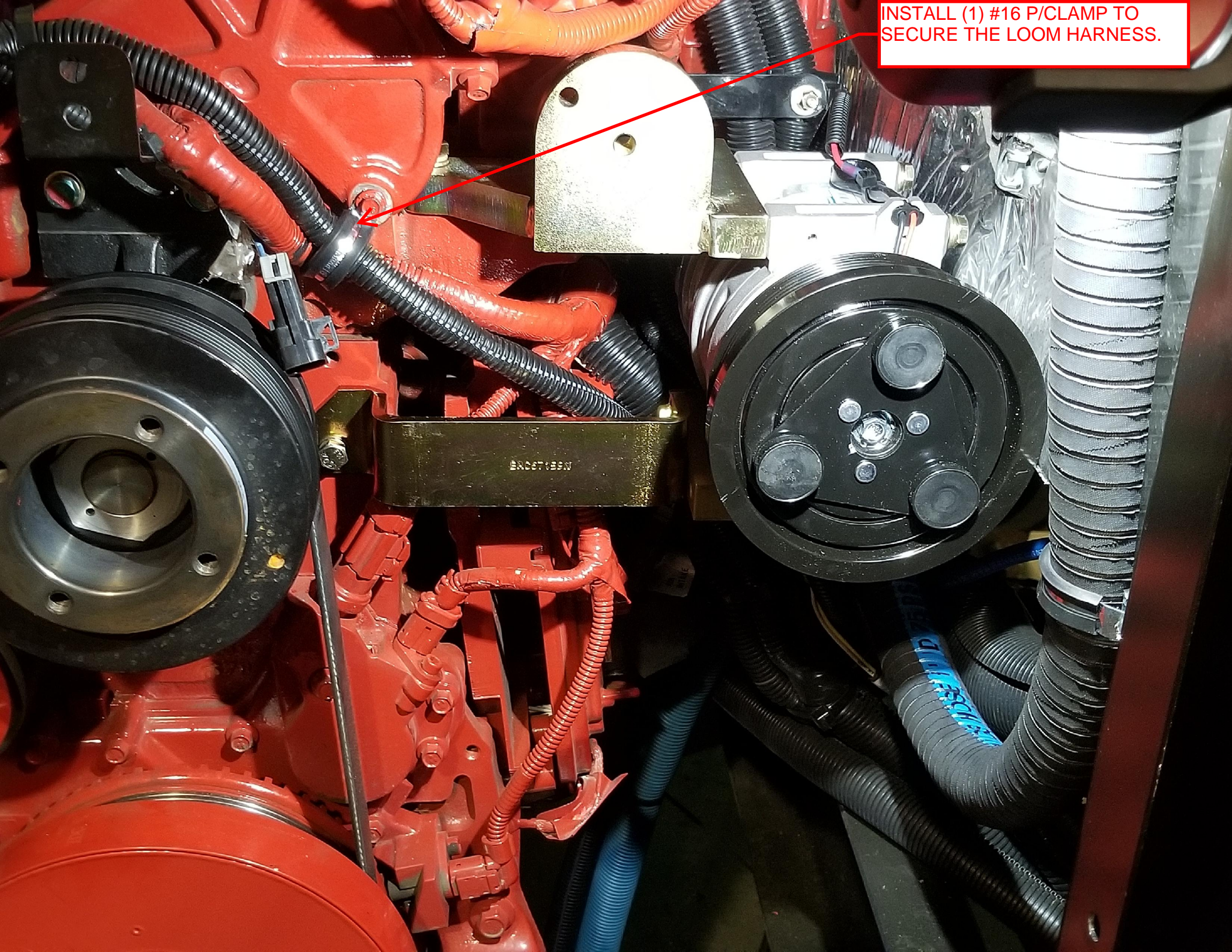

**NOTE: ONLY ON 2010 & 2013
EMISSIONS BUSES ONLY.
INSTALL (2) ADDITIONAL #20
P/CLAMPS TO SUIT WIRING HARNESS
ROUTING.**



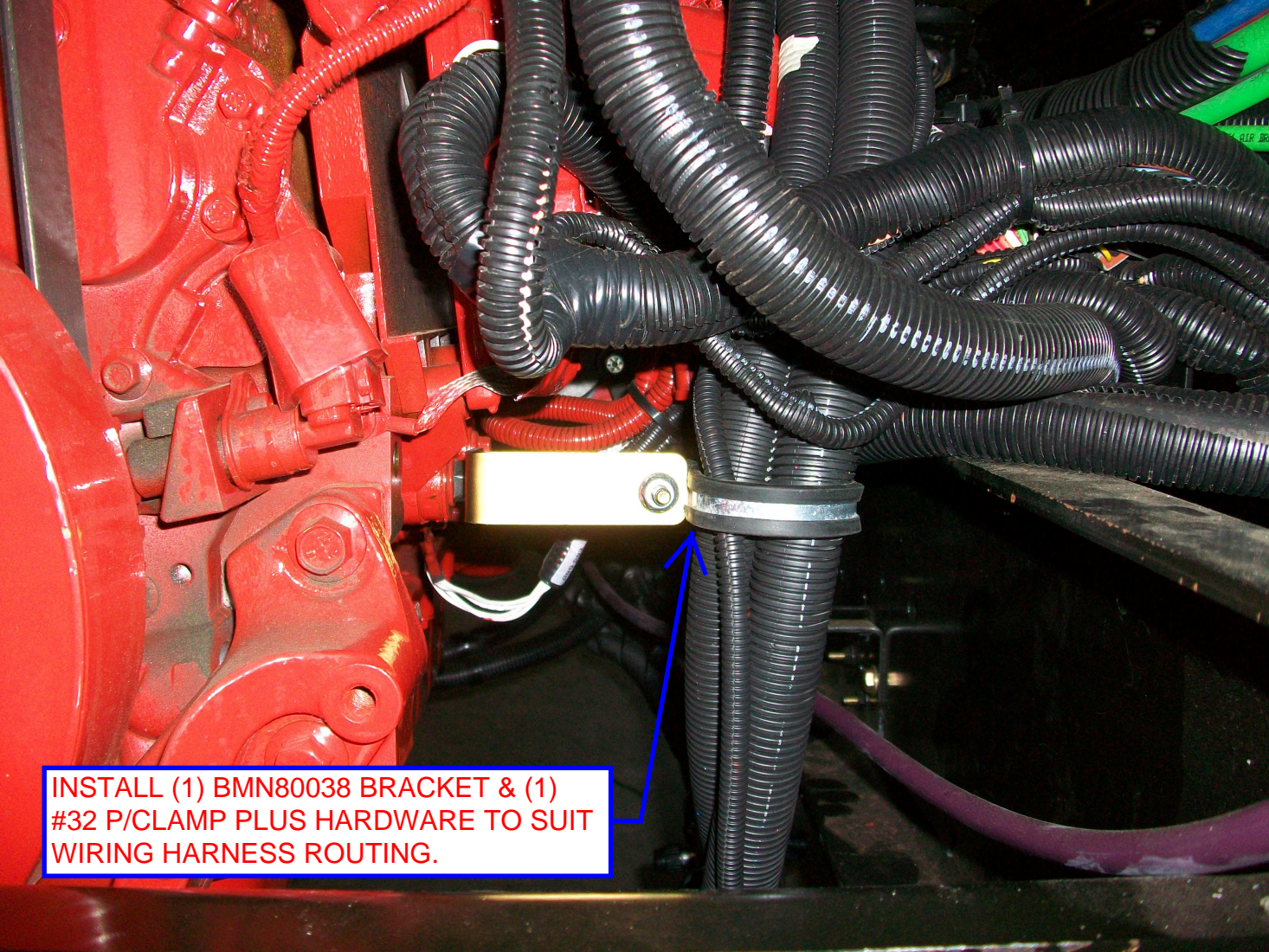

**INSTALL (1) BMN80038 BRACKET & (1)
#32 P/CLAMP PLUS HARDWARE TO SUIT
WIRING HARNESS ROUTING.**

5 FT OF HOA01002
USE (2) EXISTING CLAMPS.
NOTE: ON 2013+ FE_USE (2)
CLP20020 P-CLAMPS.

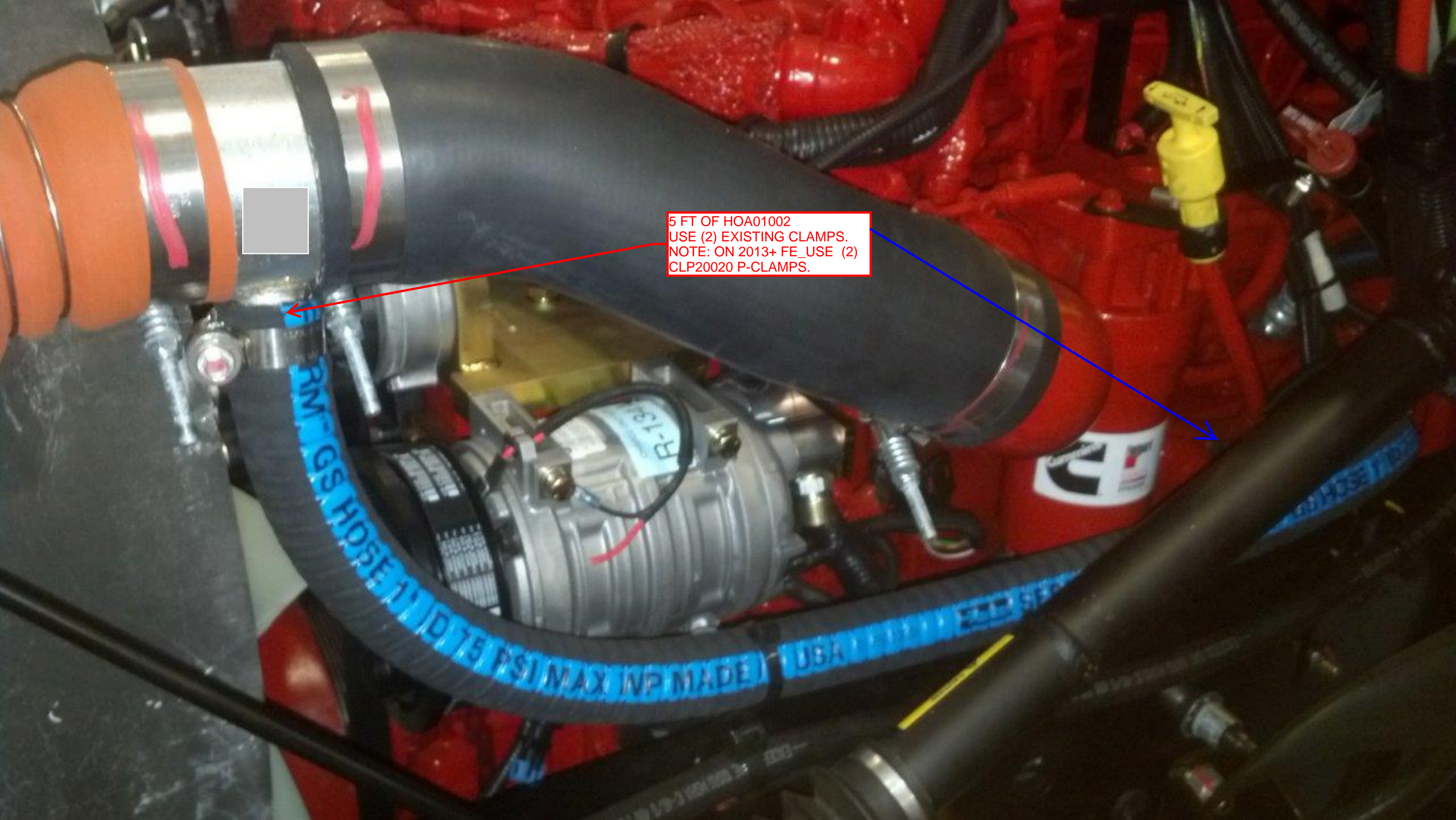
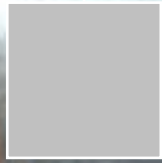



NOTE: ONLY ON 2013+ FE
_USE (2) CLP20020 #20 P/CLAMPS.



USE (2) BMC00028 BRACKETS
TO SECURE THE LOOMED
HOSES.

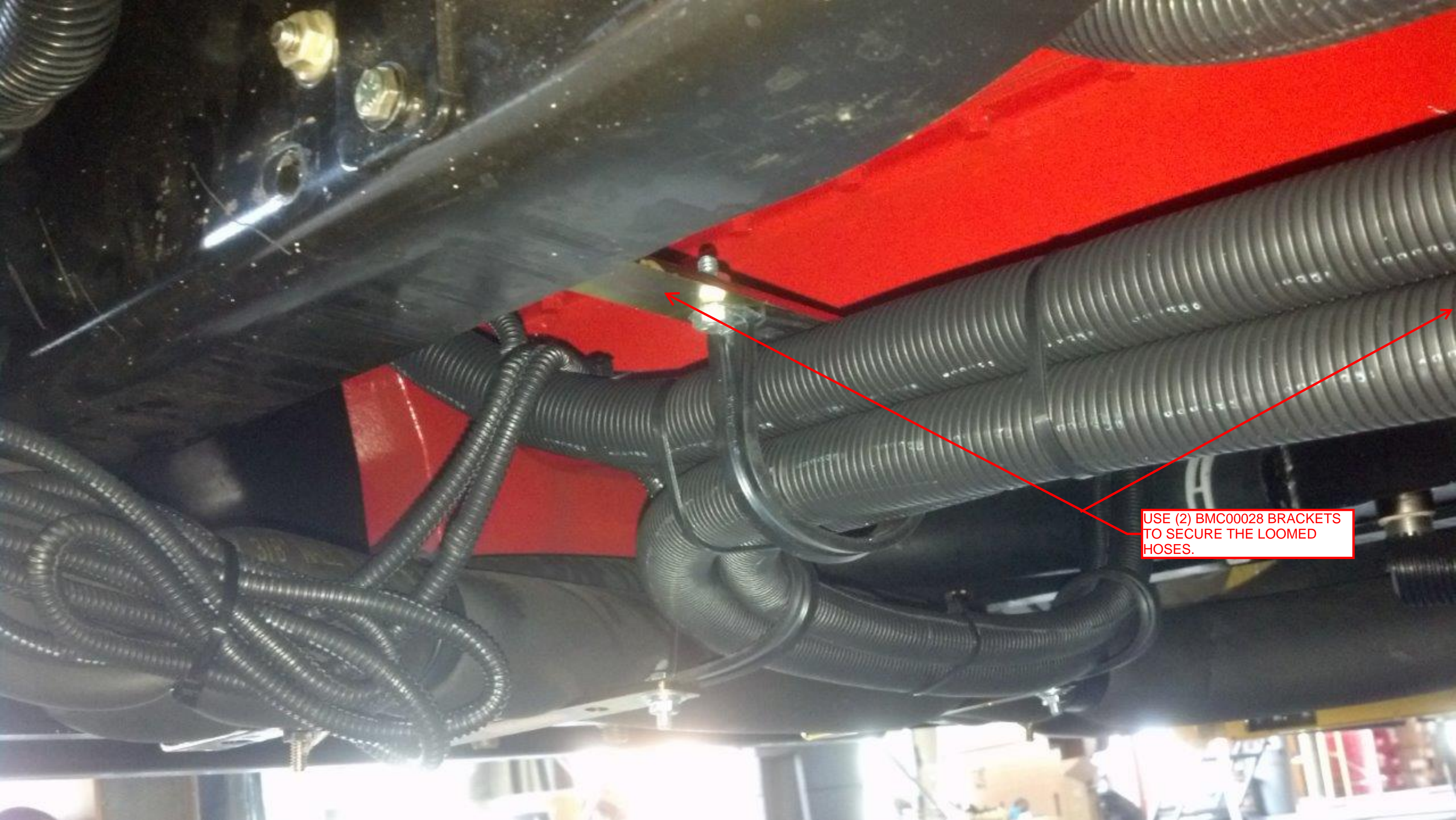

USE (2) BMC00028 BRACKETS
TO SECURE THE LOOMED
HOSES.

TransArctic A/C Compressor Mount Installation Disclaimer

All compressor mounts should be installed by qualified and trained personnel using proper tools and equipment in safe working conditions following industry standard guidelines for motor vehicle service and repair.

The installer of any compressor mount purchased from TransArctic must undertake all responsibility of issues arising from that compressor bracket being installed on any vehicle. As well as insure that a **proper and sufficient ground** is established between the compressors' clutches and the vehicle's engine. Mount functionality, operation and durability can all be compromised by an incompetent installation.

Due to the many different situations, parameters and application criteria, which are beyond the compressor mount manufacturer's control, TransArctic does not warrant design, durability, or operational functionality of any compressor mount improperly installed by another party.

With no implied guarantees it is the mount installer's strict responsibility to determine safety and functionality, of the compressor mount, at the time of installation.

Please contact TransArctic with any issue arising from installation so we may better improve the product. If you have any reservations about the compressor mount integrity contact TransArctic immediately at 1-877-COLD-AIR.

Mark OEM tensioner location

Install Kit

Check for Interferences

Check to ensure that the proper OEM tensioner orientation is maintained

Run engine with A/C system engaged for at least 10 minutes to run in belt

Check OEM tensioner orientation and adjust as required

Responsabilidad limitada de TransArctic en la instalación del soporte del compresor

Todos los soportes de los compresores deben ser instalados por personas calificadas y entrenadas, usando para ello los equipos y herramientas necesarios para esta labor en buenas condiciones y según las normas y guías para el servicio y/o reparación de motores de vehículos.

El instalador de los soportes comprados en TransArctic asume toda la responsabilidad de cualquier problema que surga en el soporte del compresor al vehículo; de igual manera es responsable que el cable a tierra sea conectado entre el embrague del compresor y el motor del vehículo.

Se advierte que el buen funcionamiento y la durabilidad del soporte pueden ser comprometidos por defectos en su instalación.

Debido a las diversas situaciones que se puedan presentar fuera del control del fabricante, TransArctic no garantiza el diseño, la durabilidad o el correcto funcionamiento de cualquier equipo inapropiadamente instalado por terceros.

Esta sobreentendido que el Instalador del montaje del compresor es estrictamente responsable de la seguridad y funcionamiento del equipo en el momento de la instalación.

Si tuviera algún problema o duda acerca de la instalación del soporte del compresor pongase en contacto inmediatamente con TransArctic al teléfono 1-877-COLD-AIR de modo que podamos mejorar nuestro producto.

Note la ubicación del medidor de tensión OEM

Instale el equipo

Controlar si hay interferencias.

Asegure que el medidor de tensión mantenga la orientación justa.

Encienda el motor por lo menos 10 minutos con el sistema A/C enganchado para que la correa corra

Controle la orientación justa del medidor de tensión y ajuste a las condiciones requeridas del fabricante