

# Bill of Materials Listing

TransArctic Canada Inc.

10/11/2019  
Page 1 of 1

Product Number	Description	Rev#	Date	Weight	Uof M	Yield
Line	Component Prod#	Bin	Unit	Qty		
<b>KMC61054</b>	<b>Mt Kit, ISB, 6.7L, BBCV, 1 TM-16, '11+</b>	<b>2</b>	<b>5/14/2010</b>	<b>27.75</b>		<b>0</b>
5	PAC12110		Pack, Carton, 12" x 11" x 5", 51 ECT	each	1	
10	BEL61118		Belt, 6gr, 1118mm (44") (5060440)	each	1	
20	BMC67050		Bkt, Main, Weldmt, ISB, D3FE, 2010	each	1	
30	BMC67053		Bkt, Cradle, BTM, 87mm, ISB, D3FE, 2010	each	1	
40	BMC67159		Bkt,S/Bar,Weldmt,ISB,D3/T3RE/FE/BBCV,10+	each	1	
45	BMN80038		Bkt, Rad Hose, PMax DT, CE300	each	1	
47	CLP20016		Clamp, "P" type, #16, 1/2"w, 1", PC	each	1	
48	CLP20032		Clamp, "P" type, #32, 1/2"w, 2", PC	each	1	
49	HOA01002		Hose, Air, 1" ID	foot	3.42	
50	TEN80005		Tenr, HD Spring, BackSide, CCW (89430)	each	1	
60	KBC61354		Bag Kt, Fast'ns, KMC61354/1054	each	1	

**NOTES:**

1) SEP-10-13\_Added (41 in) HOA01002 & use (2) existing C/T clamps to make this kit work on a 2013 emissions engine.

# Bill of Materials Listing

TransArctic Canada Inc.

10/11/2019  
Page 1 of 1

Product Number		Description	Rev#	Date	Weight	Uof M	Yield
Line	Component Prod#	Description	Bin	Unit	Qty		
<b>KBC61354</b>		<b>Bag Kt, Fast'ns, KMC61354/1054</b>		<b>5/14/2010</b>	<b>0.99</b>		<b>0</b>
10	BTC10080	Bolt, Hex, 10 x 1.5 x 80mm, 10.9, Plt,FT		each	1		
20	BTC10040	Bolt, Hex, 10 x 1.5 x 40mm, 10.9, Plt,FT		each	2		
30	BTC10030	Bolt, Hex, 10 x 1.5 x 30mm, 10.9, Plt		each	1		
40	BTC08100	Bolt, Hex, 8 x 1.25 x 100mm, 10.9, Plt		each	4		
45	BTC08045	Bolt, Hex, 8 x 1.25 x 45mm, 10.9, Plt		each	1		
65	BTC08025	Bolt, Hex, 8 x 1.25 x 25mm, 10.9, Plt		each	1		
72	BTP04100	Bolt, Hex, 1/4-20unc, 1", 5, Plt		each	1		
74	NTA08000	Nut, Hex, 8 x 1.25, 8.8, Plt		each	1		
76	NTP04000	Nut, Hex, 1/4-20unc, 5, Plt		each	1		
80	WFA10000	Washer, Flat, 10mm, 8.8, Plt		each	4		
90	WFA08000	Washer, Flat, 8mm, 8.8, Plt		each	6		
95	WFP04000	Washer, Flat, 1/4", 5, Plt		each	1		
100	WLA10000	Washer, Lock, 10mm, 8.8, Plt		each	4		
110	WLA08000	Washer, Lock, 8mm, 8.8, Plt		each	6		
120	WLP04000	Washer, Lock, 1/4", 5, Plt		each	1		

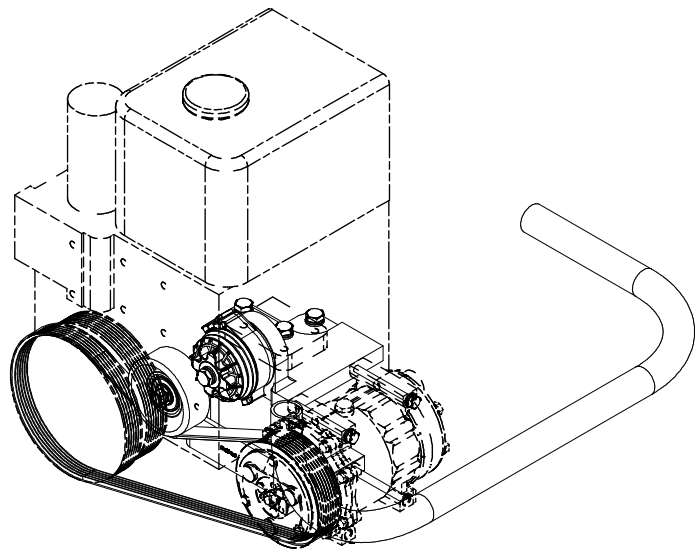
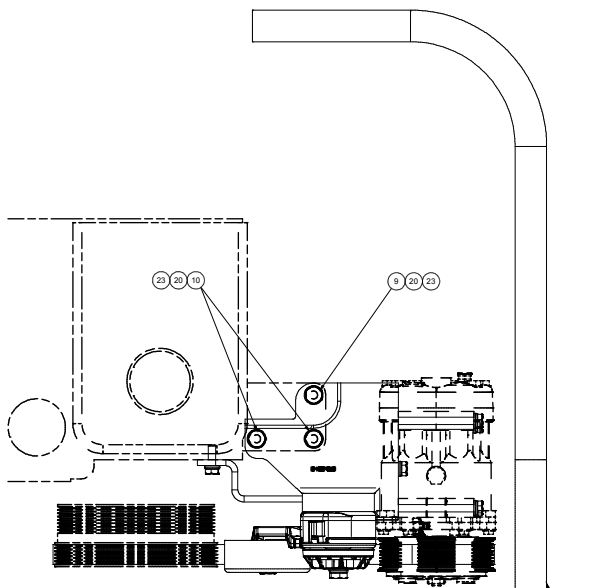

ISOMETRIC VIEW

NOTE:  
INSTALL THE 6 GR. BELT ON THE  
MIDDLE 6 GROOVES OF THE 8 GR.  
COMPRESSOR PULLEY.

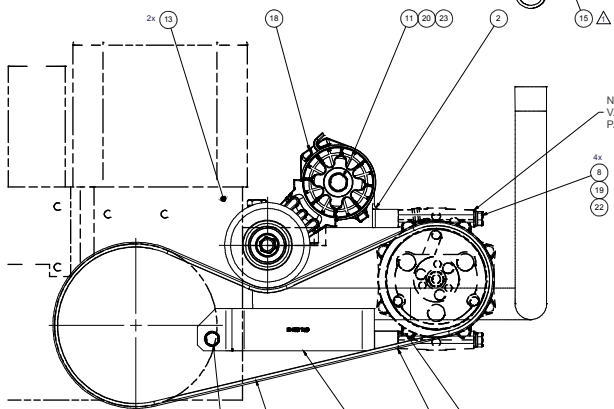

NOTE:  
VALEO COMPRESSOR  
PART#: 103-56282

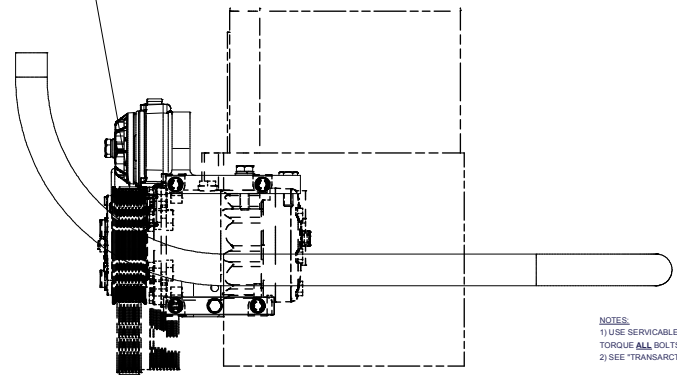

NOTES:  
1) USE SERVICABLE THREADLOCKER ON ALL FASTENERS TO ENGINE COMPONENTS AND TORQUE ALL BOLTS TO S.A.E. SPECIFICATIONS.  
2) SEE "TRANSARGTIC AC COMPRESSOR MOUNT INSTALLATION DISCLAIMER".

ITEM	QTY	UOM	PART NUMBER	DESCRIPTION
24	1	EACH	WL04000	WASHER LOCK, 1/4", 5, PLT
23	4	EACH	WLA10000	WASHER LOCK, 10mm, 8.8, PLT
22	6	EACH	WLA08000	WASHER LOCK, 8mm, 8.8, PLT
21	1	EACH	WFA08000	WASHER FLAT, 1/4", 5, PLT
20	4	EACH	WFA10000	WASHER FLAT, 10mm, 8.8, PLT
19	6	EACH	WFA06000	WASHER FLAT, 8mm, 8.8, PLT
18	1	EACH	TEN00000	TENR. HD SPRNGS, BACKSIDE, CCW (#9430)
17	1	EACH	NTP04000	NUT, HEX, 1/4-20UNC, 5, PLT
16	1	EACH	NTA08000	NUT, HEX, 8 X 1.25, 8.8, PLT
15	1	EACH	H0A01002	Hose, Av, 1" ID
14	2	EACH	CLP20002	CLAMP "P" TYPE, #32, 1/2"W, 2" PC
13	2	EACH	CLP20020	CLAMP "P" TYPE, #20, 1/2"W, 1 1/4" PC
12	1	EACH	BTP04100	BOLT, HEX, 1/4-20UNC, 1" 5, PLT
11	1	EACH	BTC10000	BOLT, HEX, 10 x 1.5 x 60mm, 10.9, PLT
10	2	EACH	BTC10040	BOLT, HEX, 10 x 1.5 x 40mm, 10.9, PLT
9	1	EACH	BTC10030	BOLT, HEX, 10 x 1.5 x 30mm, 10.9, PLT
8	4	EACH	BTC08100	BOLT, HEX, 8 x 1.25 x 100mm, 10.9, PLT
7	1	EACH	BTC08045	BOLT, HEX, 8 x 1.25 x 45mm, 10.9, PLT
6	1	EACH	BTC08025	BOLT, HEX, 8 x 1.25 x 25mm, 10.9, PLT
5	1	EACH	BM080038	BKT, RAD HOSE, MAX. O.D. 38.00
4	1	EACH	BM037159	BKT, S-Bar WELDMT, ISB D373RE/FE/BBCV, 10+
3	1	EACH	BM027053	BKT, CRADLE, BTM, 87mm, ISB, D3FE, 2010
2	1	EACH	BM027050	BKT, MAIN WELDMT, ISB, D3FE, 2010
1	1	EACH	BE161118	BELT, 6 gr, 1118mm (44")

DRAWN: **vjakowlew** DATE: 12/7/2011  
 CHECKED: **Jose Rodriguez** DATE: 12/7/2011  
 REV: **DA** DATE: 10/4/2011  
 REV: **ECN** DESCRIPTION: DATE: BY: James Stewart 10/4/2011  
 APPROVED: **DAke Mason** DATE: 12/7/2011  
 TITLE: **MT KIT, ISB, 6.7L, BBCV, 1 TM-16, '11+**  
 SCALE: **E**  
 SHEET: **1** OF **1**

**TRANSARGTIC INC.**  
 10000 W. 10th Ave., Suite 100, Denver, CO 80202  
 TEL: 303.751.1000 FAX: 303.751.1001  
 WWW.TRANSARGTIC.COM

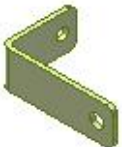
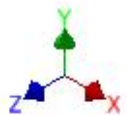
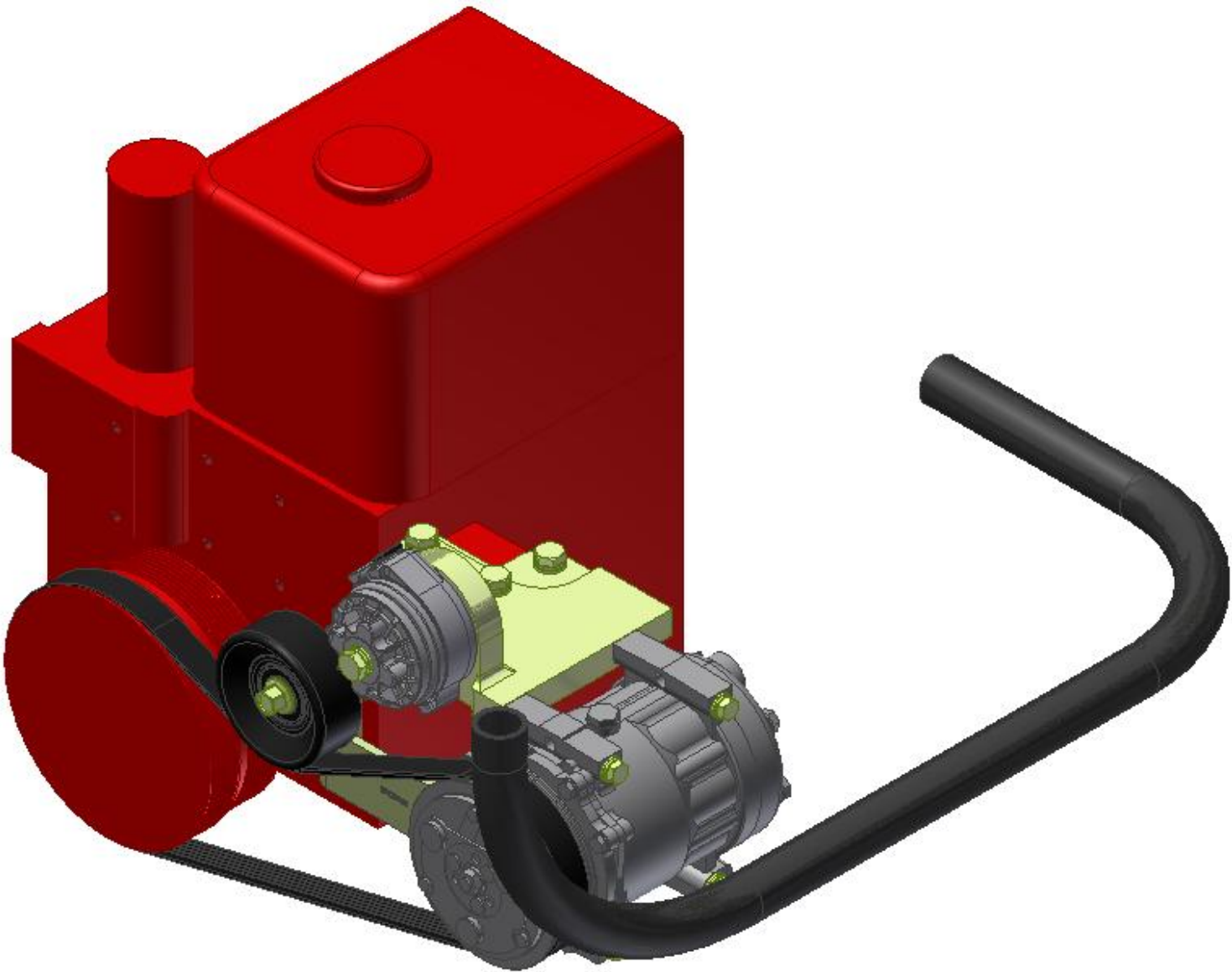

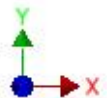
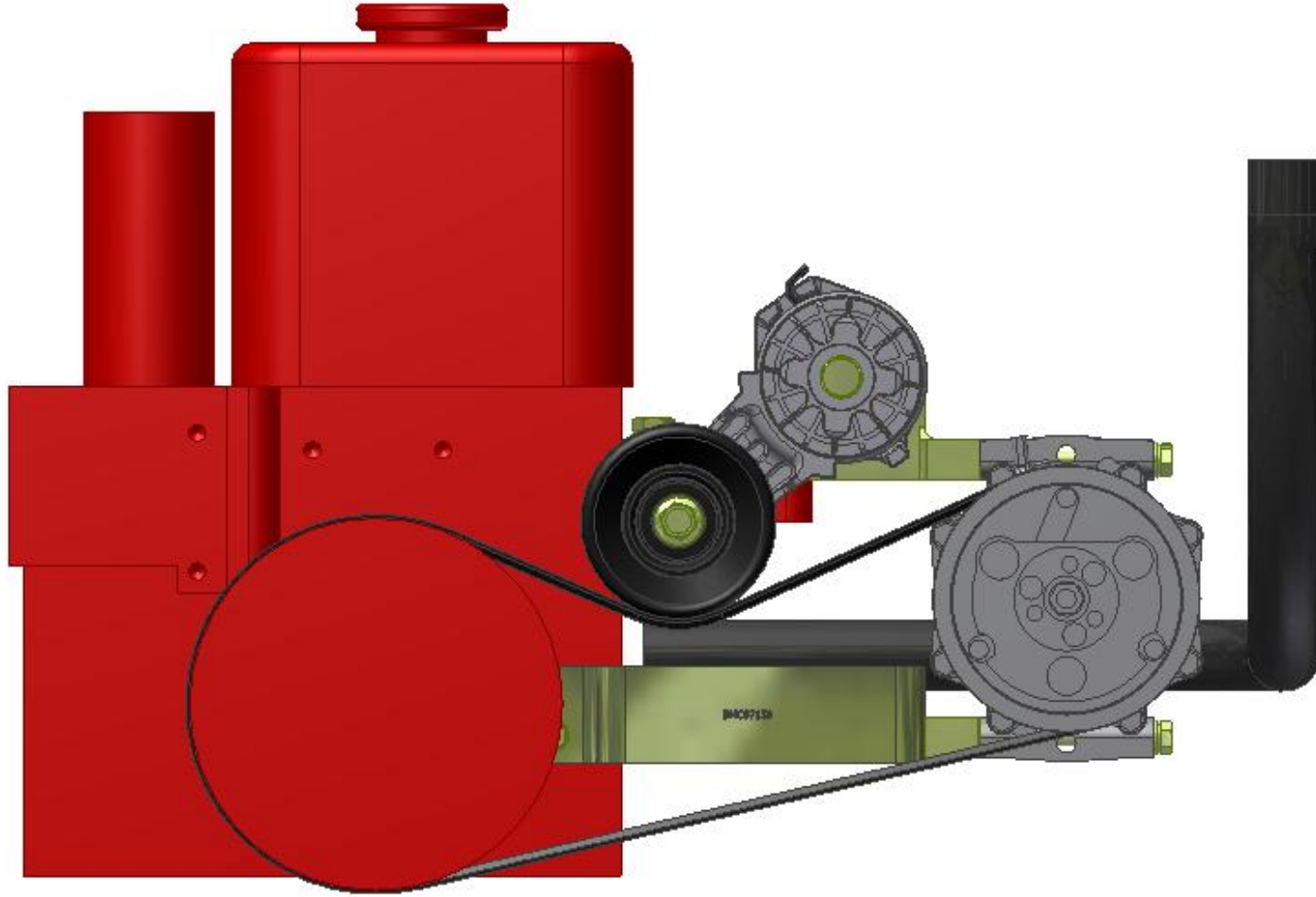

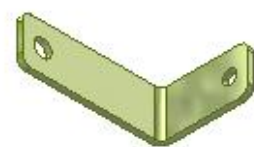
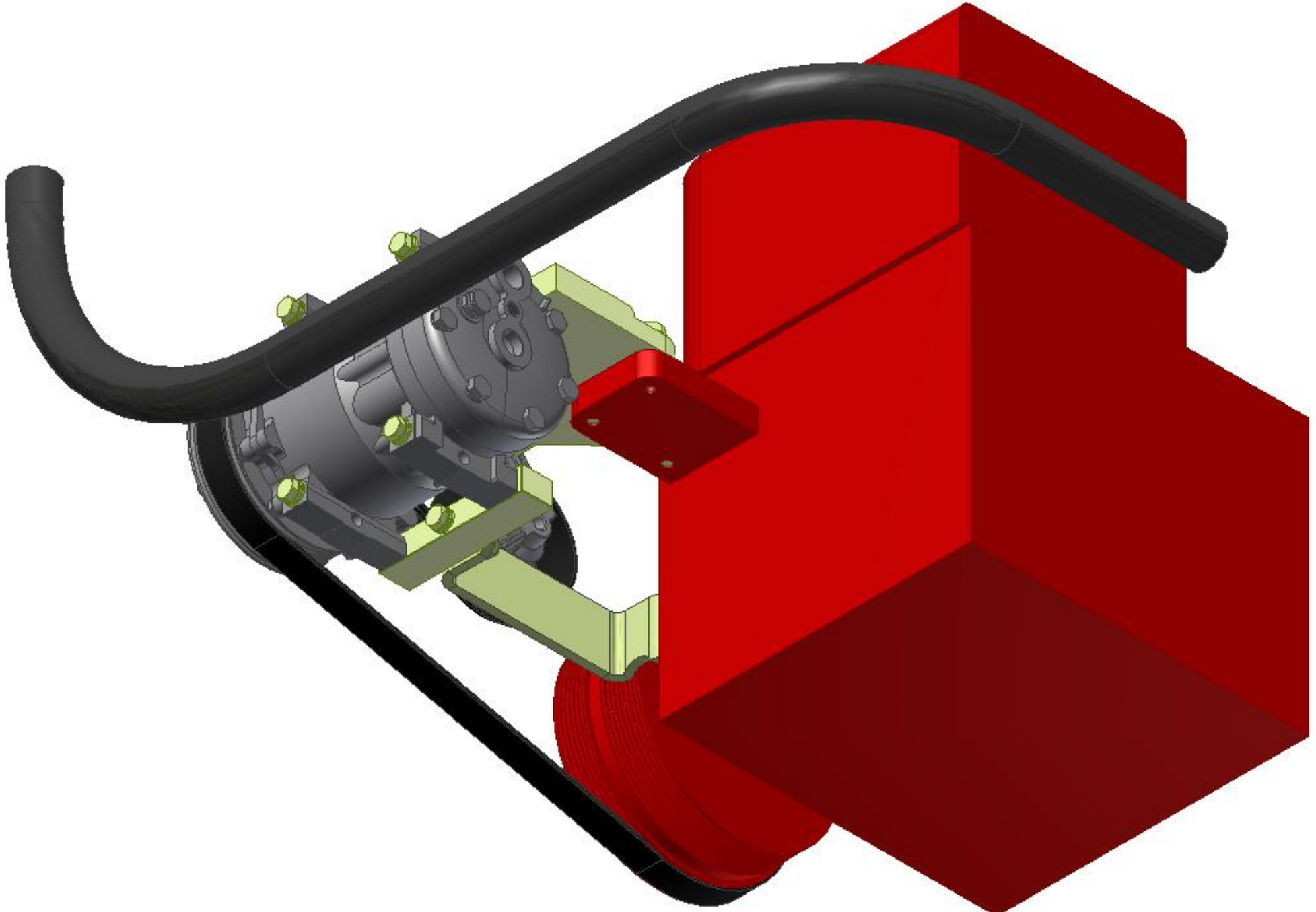

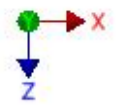
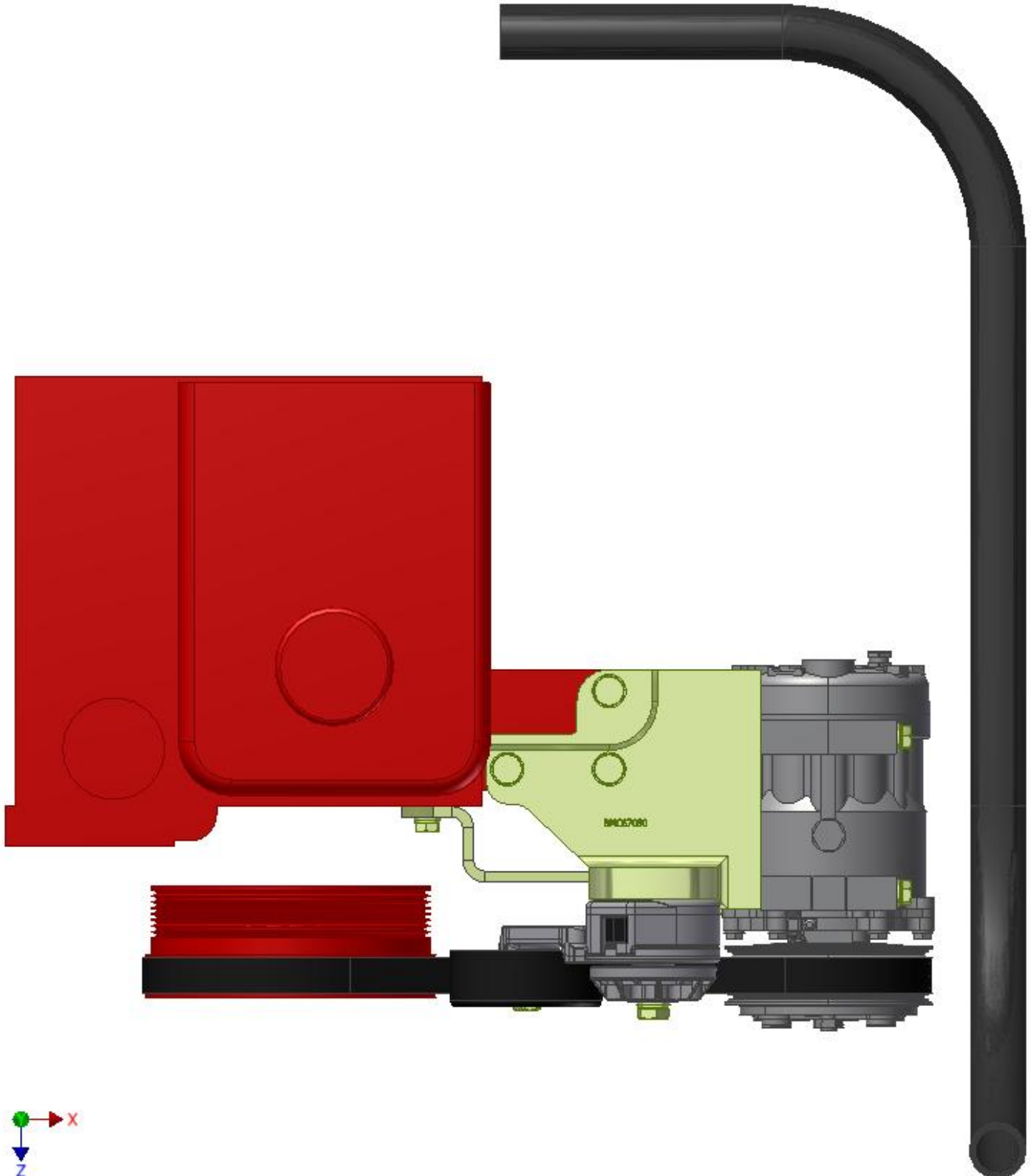

INSTALL (1) #16 P/CLAMP TO SECURE THE LOOM HARNESS.

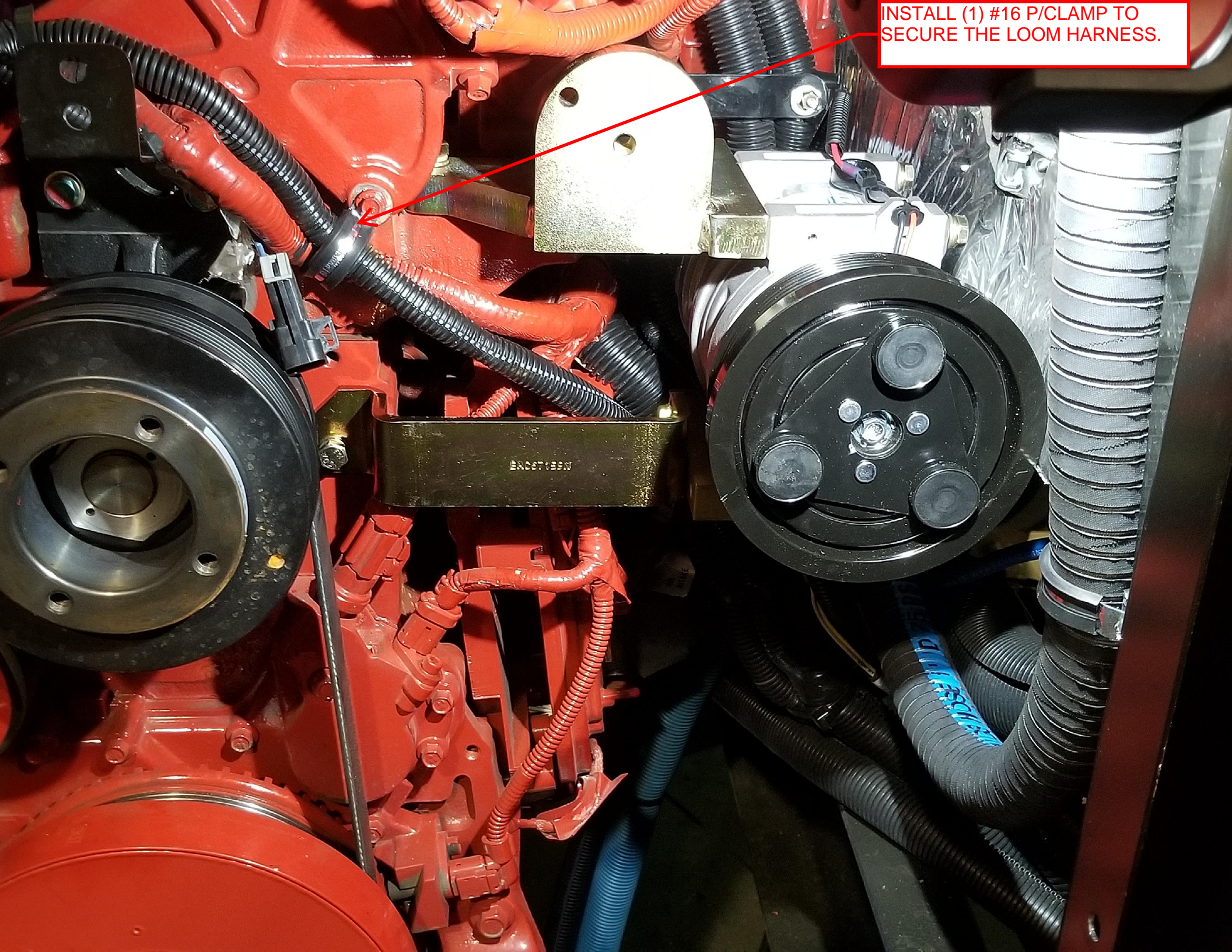



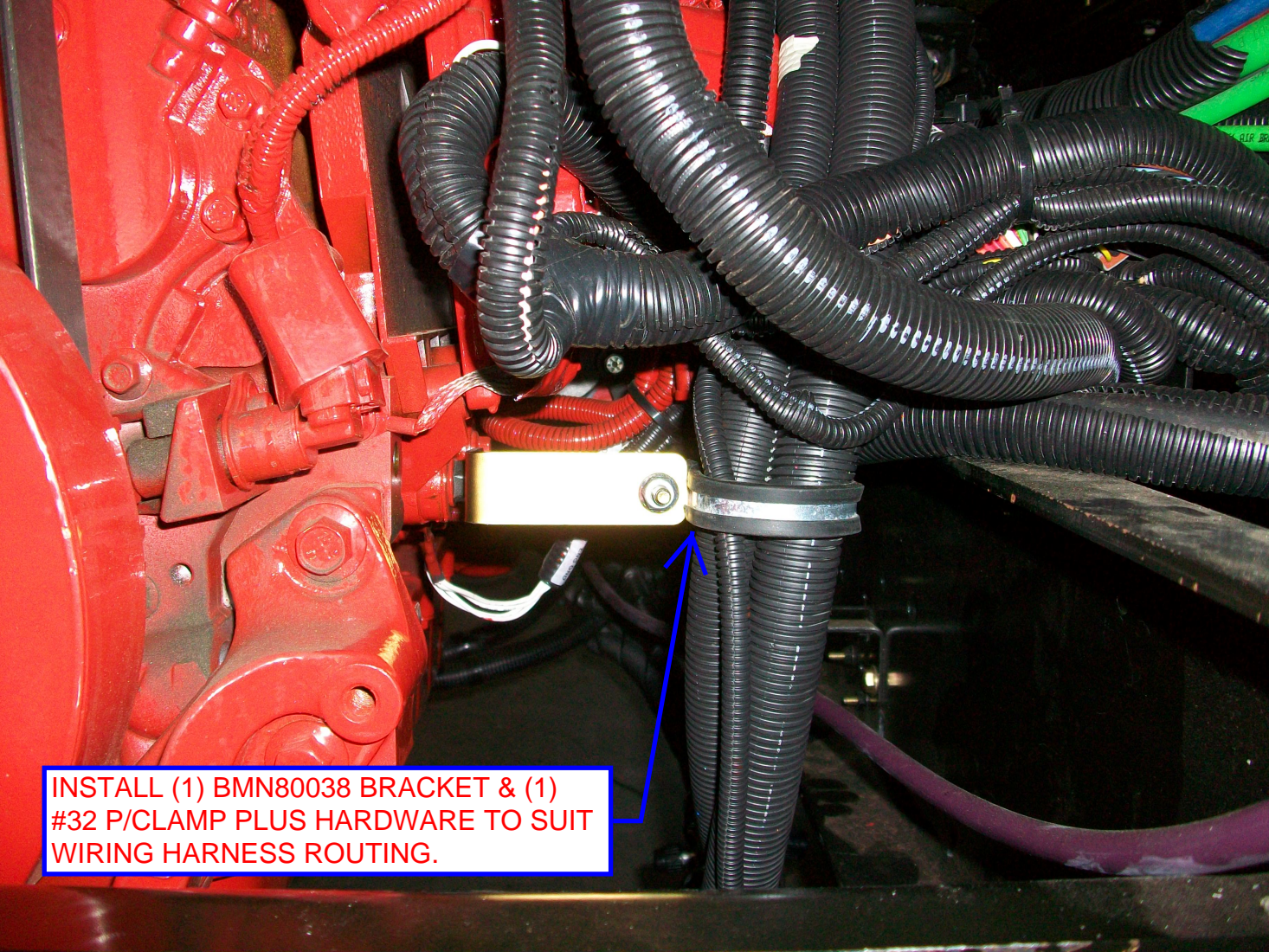

**INSTALL (1) BMN80038 BRACKET & (1)  
#32 P/CLAMP PLUS HARDWARE TO SUIT  
WIRING HARNESS ROUTING.**

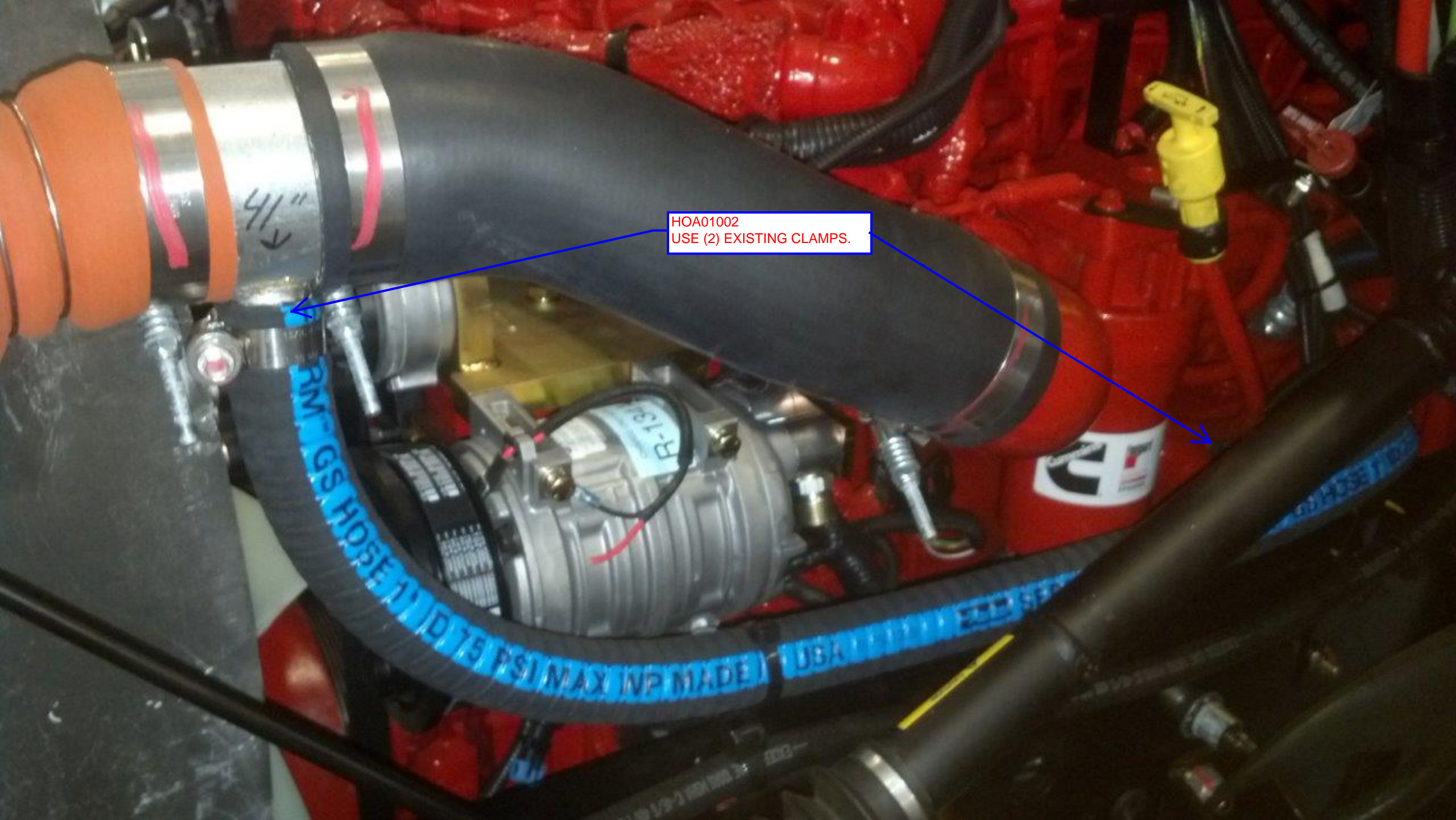

HOA01002  
USE (2) EXISTING CLAMPS.

41"  
↘

RPM - GGS HOSE 1" ID T5 PSI MAX WP MADE

R-130

UGA



## **TransArctic A/C Compressor Mount Installation Disclaimer**

All compressor mounts should be installed by qualified and trained personnel using proper tools and equipment in safe working conditions following industry standard guidelines for motor vehicle service and repair.

The installer of any compressor mount purchased from TransArctic must undertake all responsibility of issues arising from that compressor bracket being installed on any vehicle. As well as insure that a **proper and sufficient ground** is established between the compressors' clutches and the vehicle's engine. Mount functionality, operation and durability can all be compromised by an incompetent installation.

Due to the many different situations, parameters and application criteria, which are beyond the compressor mount manufacturer's control, TransArctic does not warrant design, durability, or operational functionality of any compressor mount improperly installed by another party.

**With no implied guarantees it is the mount installer's strict responsibility to determine safety and functionality, of the compressor mount, at the time of installation.**

Please contact TransArctic with any issue arising from installation so we may better improve the product. If you have any reservations about the compressor mount integrity contact TransArctic immediately at 1-877-COLD-AIR.

**Mark OEM tensioner location**

**Install Kit**

**Check for Interferences**

**Check to ensure that the proper OEM tensioner orientation is maintained**

**Run engine with A/C system engaged for at least 10 minutes to run in belt**

**Check OEM tensioner orientation and adjust as required**

### **Responsabilidad limitada de TransArctic en la instalación del soporte del compresor**

Todos los soportes de los compresores deben ser instalados por personas calificadas y entrenadas, usando para ello los equipos y herramientas necesarios para esta labor en buenas condiciones y según las normas y guías para el servicio y/o reparación de motores de vehículos.

El instalador de los soportes comprados en TransArctic asume toda la responsabilidad de cualquier problema que surja en el soporte del compresor al vehículo; de igual manera es responsable que el cable a tierra sea conectado entre el embrague del compresor y el motor del vehículo.

Se advierte que el buen funcionamiento y la durabilidad del soporte pueden ser comprometidos por defectos en su instalación.

Debido a las diversas situaciones que se puedan presentar fuera del control del fabricante, TransArctic no garantiza el diseño, la durabilidad o el correcto funcionamiento de cualquier equipo inapropiadamente instalado por terceros.

**Esta sobreentendido que el Instalador del montaje del compresor es estrictamente responsable de la seguridad y funcionamiento del equipo en el momento de la instalación.**

Si tuviera algún problema o duda acerca de la instalación del soporte del compresor pongase en contacto inmediatamente con TransArctic al teléfono 1-877-COLD-AIR de modo que podamos mejorar nuestro producto.

**Note la ubicación del medidor de tensión OEM**

**Instale el equipo**

**Controlar si hay interferencias.**

**Asegure que el medidor de tensión mantenga la orientación justa.**

**Encienda el motor por lo menos 10 minutos con el sistema A/C enganchado para que la correa corra**

**Controle la orientación justa del medidor de tensión y ajuste a las condiciones requeridas del fabricante**