

Bill of Materials Listing

TransArctic Canada Inc.

6/12/2020
Page 1 of 1

Product Number	Description	Rev#	Date	Weight	Uof M	Yield
Line	Component Prod#	Bin	Unit	Qty		
KMC62680	Mt Kit, ISB, 6.7L, MVP EF,2 TM-21,'07-19	4	6/5/2004	63.79		0
5	PAC15110		Pack, Carton, 15" x 11" x 10", 51 ECT	each	1	
10	BEL83106		Belt, 8gr, 3106mm (122.3") (5081223)	each	1	
20	BMC67010		Bkt, Main, Weldmt, ISB, EF/X, '07-16	each	1	
30	BMC59007		Bkt, Assy, Block, Slide, ISB, EF, P8	each	1	
40	BMC59009		Bkt, Brace, Frt, Diag, ISB, EF, P8	each	1	
55	BMC59032		Bkt, Angle, Alt, ISB, EF, P8	each	1	
58	BMC67061		Bkt, Angle, Brace, CAC, 2010	each	1	
60	PUL80074		Pulley, Idler, B/S, Wide, 74d (89102)	each	1	
62	GP101E		Ftg, Pipe, TEE, 3/4"npt, Galv	each	1	
64	GP110EB-M		Ftg, Pipe, Reducer, 3/4"npt x 9/16-18nf	each	1	
66	MAGI34		Ftg, Pipe, Barb, 3/4"npt to 3/4" d, Galv	each	2	
68	S3621-6		Ftg, Pipe, Plug, 9/16-18 ORB, Brass	each	1	
70	SCD25408	Alley	Spacer, Col, Drl, 25.4mm x 25.4o x 8.33i	each	4	
73	HOA03063		Hose, Flex, CAC, 3.0d x 6.0, 3 ring	each	1	
75	CLP03000		Clamp, T bolt, Spring, 3", CAC	each	2	
77	CLP16002		Clamp, Cons/Torq, #16,.813-1.5"(20/38mm)	each	2	
80	KBC62680		Bag Kit, Fasteners, KMC62680/KMC62080	each	1	

-For 2017 buses installer is to use supplied (4) M10 x 70mm long Alternator bolts.

-Prior year buses will need to confirm OEM fasteners lengths and substitute with supplied 80mm long bolts to suit their 70-75 mm application.

Bill of Materials Listing

TransArctic Canada Inc.

6/12/2020
Page 1 of 1

Product Number		Description	Rev#	Date	Weight	Uof M	Yield
Line	Component Prod#	Description	Bin	Unit	Qty		
KBC62680		Bag Kit, Fasteners, KMC62680/KMC62080	2	6/7/2004	2.87		0
10	BTS10001	Bolt, Shoulder, 10mm (89064)		each	1		
20	BTC10080	Bolt, Hex, 10 x 1.5 x 80mm, 10.9, Plt,FT		each	5		
40	BTC10030	Bolt, Hex, 10 x 1.5 x 30mm, 10.9, Plt		each	1		
50	BTC08130	Bolt, Hex, 8 x 1.25 x 130mm, 10.9, Plt		each	4		
60	BTC08100	Bolt, Hex, 8 x 1.25 x 100mm, 10.9, Plt		each	4		
63	BTC08035	Bolt, Hex, 8 x 1.25 x 35mm, 10.9, Plt,FT		each	2		
65	BTC08030	Bolt, Hex, 8 x 1.25 x 30mm, 10.9, Plt,FT		each	1		
70	BTC08025	Bolt, Hex, 8 x 1.25 x 25mm, 10.9, Plt		each	10		
72	BTC06040	Bolt, Hex, 6 x 1.0 x 40mm, 10.9, Plt		each	1		
80	NTA10000	Nut, Hex, 10 x 1.5, 8.8, Plt		each	5		
85	NTA08000	Nut, Hex, 8 x 1.25, 8.8, Plt		each	1		
100	WFA10000	Washer, Flat, 10mm, 8.8, Plt		each	9		
110	WFA08000	Washer, Flat, 8mm, 8.8, Plt		each	20		
115	WFA06000	Washer, Flat, 6mm, 8.8, Plt		each	1		
120	WLA10000	Washer, Lock, 10mm, 8.8, Plt		each	10		
130	WLA08000	Washer, Lock, 8mm, 8.8, Plt		each	21		
140	WLA06000	Washer, Lock, 6mm, 8.8, Plt		each	1		

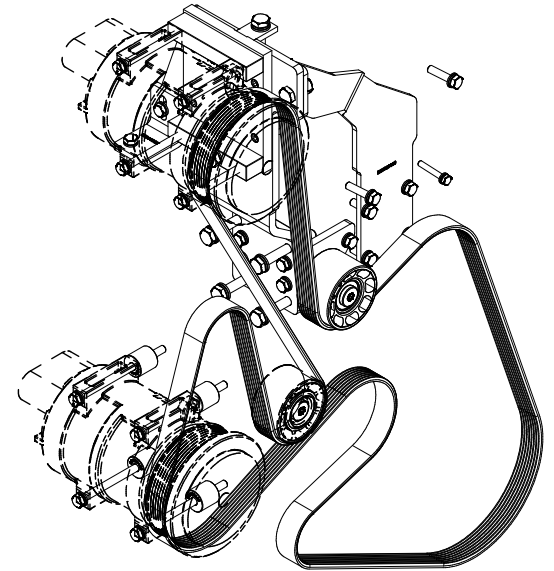
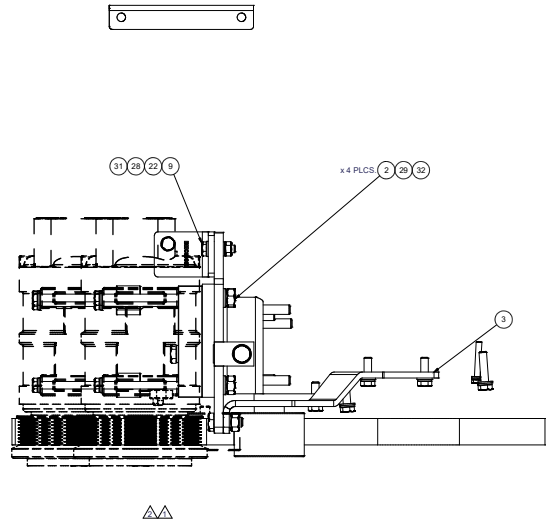

ISOMETRIC VIEW

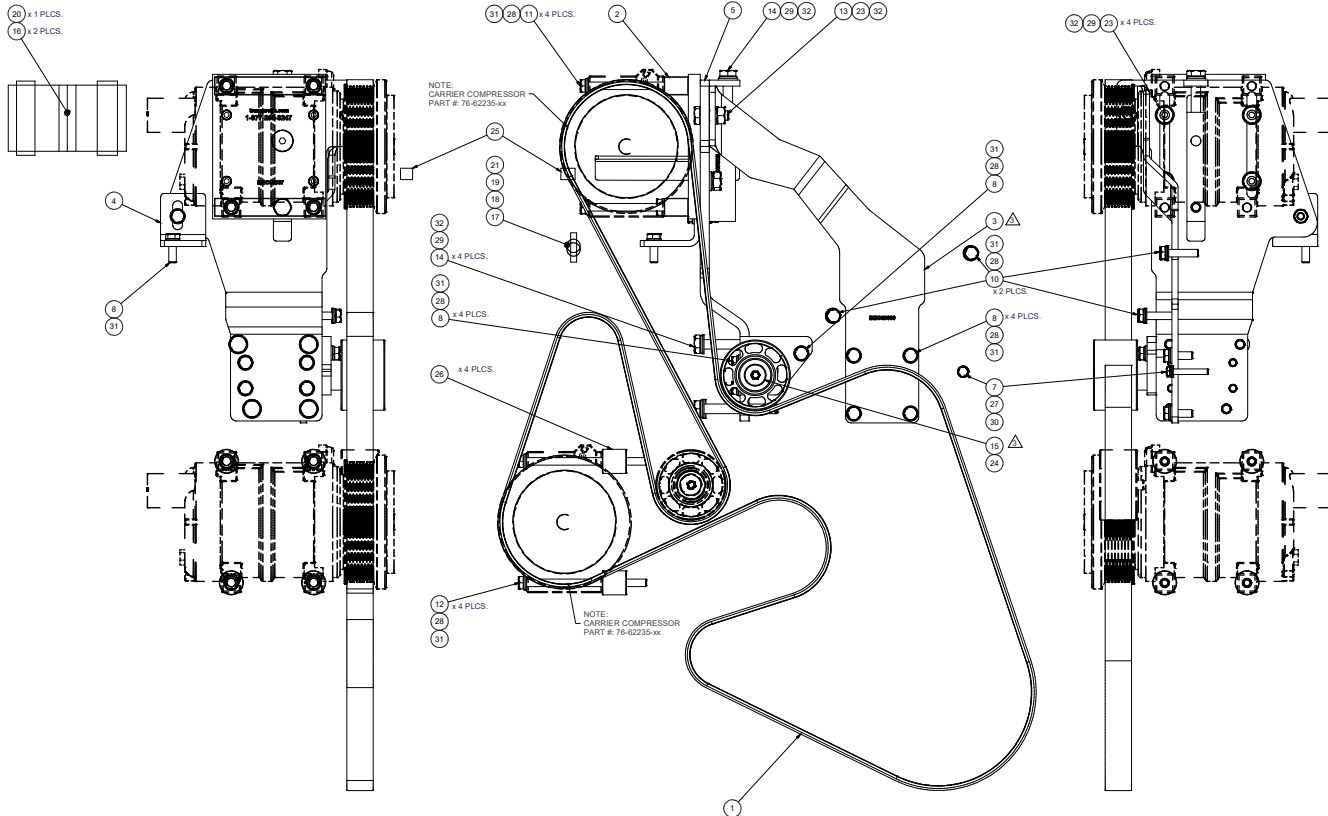

NOTE
CARRIER COMPRESSOR
PART #: 76-62235-xx

NOTE
CARRIER COMPRESSOR
PART #: 76-62235-xx

- NOTES
- 1) USE SERVICABLE THREADLOCKER ON ALL FASTENERS TO ENGINE COMPONENTS AND TORQUE ALL BOLTS TO S.A.E. SPECIFICATIONS.
 - 2) SEE "TRANSARCTIC AC COMPRESSOR MOUNT INSTALLATION DISCLAIMER".
 - 3) REMOVE ALTERNATOR, MOUNT CASTING AND LIFTING LUG & REPLACE THE LIFT LUG WITH ITEM BMS2010 AND REINSTALL ALTERNATOR AND MOUNT CASTING.
 - 4) REPLACE OEM IDLER MOUNT (BELOW ALTERNATOR) & PULLEY WITH LOWER COMPRESSOR o/w HARDWARE.

ITEM	QTY	U/M	PART NUMBER	DESCRIPTION
32	10	EACH	WLA10000	WASHER LOCK, 10mm, 8.8, PLT
31	21	EACH	WLA20000	WASHER LOCK, 8mm, 8.8, PLT
30	1	EACH	WLA60000	WASHER LOCK, 6mm, 8.8, PLT
29	9	EACH	WFA10000	WASHER FLAT, 10mm, 8.8, PLT
28	20	EACH	WFA20000	WASHER FLAT, 8mm, 8.8, PLT
27	1	EACH	WFA60000	WASHER FLAT, 6mm, 8.8, PLT
26	4	EACH	SCD25408	SPACER, COL, DRL, 25.4mm x 25.4ø x 8.331
25	1	EACH	S3621-8	FTG. PIPE, PLUG, 9/16" 18 DBR, BRASS
24	1	EACH	PLS80074	PULLEY, IDLER, BACKSIDE, PB, 74D, 48.27W
23	5	EACH	NTA10000	NUT, HEX, 10 x 1.5, 8.8, PLT
22	1	EACH	NTA20000	NUT, HEX, 8 x 1.25, 8.8, PLT
21	2	EACH	MIG14	FTG. PIPE, BARB, 3/4"NPT, GALV
20	1	EACH	HO403083	HOSE, FLEX, CAC, 3.0 x 0.0, 3 RING
19	1	EACH	GPI10EB-M	FTG. PIPE, REDUCER, 3/4"NPT x 9/16"-18NF
18	1	EACH	GP10IE	FTG. PIPE, TEE, 3/4"NPT, GALV
17	2	EACH	CLP16002	CLAMP, CONSTORQ, #16, 0.913" 1.5" (20/93MM)
16	2	EACH	CLP03000	CLAMP, T, BOLT, SPRING, 3" CAC
15	1	EACH	BTS10001	BOLT, SHOULDER, 10mm (IDLER PULLEY)
14	5	EACH	BTC10090	BOLT, HEX, 10 x 1.5 x 30mm, 10.9, FLT
13	1	EACH	BTC10030	BOLT, HEX, 10 x 1.5 x 30mm, 10.9, PLT
12	4	EACH	BTC09130	BOLT, HEX, 8 x 1.25 x 130mm, 10.9, PLT
11	4	EACH	BTC09110	BOLT, HEX, 8 x 1.25 x 110mm, 10.9, PLT
10	2	EACH	BTC08035	BOLT, HEX, 8 x 1.25 x 35mm, 10.9, PLT
9	1	EACH	BTC08030	BOLT, HEX, 8 x 1.25 x 30mm, 10.9, PLT
8	10	EACH	BTC08025	BOLT, HEX, 8 x 1.25 x 25mm, 10.9, PLT
7	1	EACH	BTC06040	BOLT, HEX, 6 x 1.0 x 40mm, 10.9, PLT, FT
6	1	EACH	BMC67061	BKT, ANGLE, BRACE, CAC, 2010
5	1	EACH	BMC63010	BKT, MARK, WELD.MT, ISB, EF, 100-18
4	1	EACH	BMC62932	BKT, BRACE, REAR, ANGLE, ISB, EF, P8
3	1	EACH	BMC62909	BKT, BRACE, FRT, DIAG, ISB, EF, P8
2	1	EACH	BMC62907	BKT, ASSY, BLOCK, SLIDE, ISB, EF, P8
1	1	EACH	BEL83106	BELT, 8 GR, 3106mm (12.2')

DRW: [blank]
CHK: [blank]
APP: [blank]
REV: [blank]
DATE: [blank]
BY: [blank]
DATE: [blank]
BY: [blank]
DATE: [blank]
BY: [blank]
DATE: [blank]
BY: [blank]
DATE: [blank]

TRANSARCTIC INC.
MT KIT, ISB, MVP-EF, 2 TM-21, '07-'19

DATE: 7/18/2007
SCALE: 1:1
SHEET: 1 OF 1



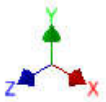
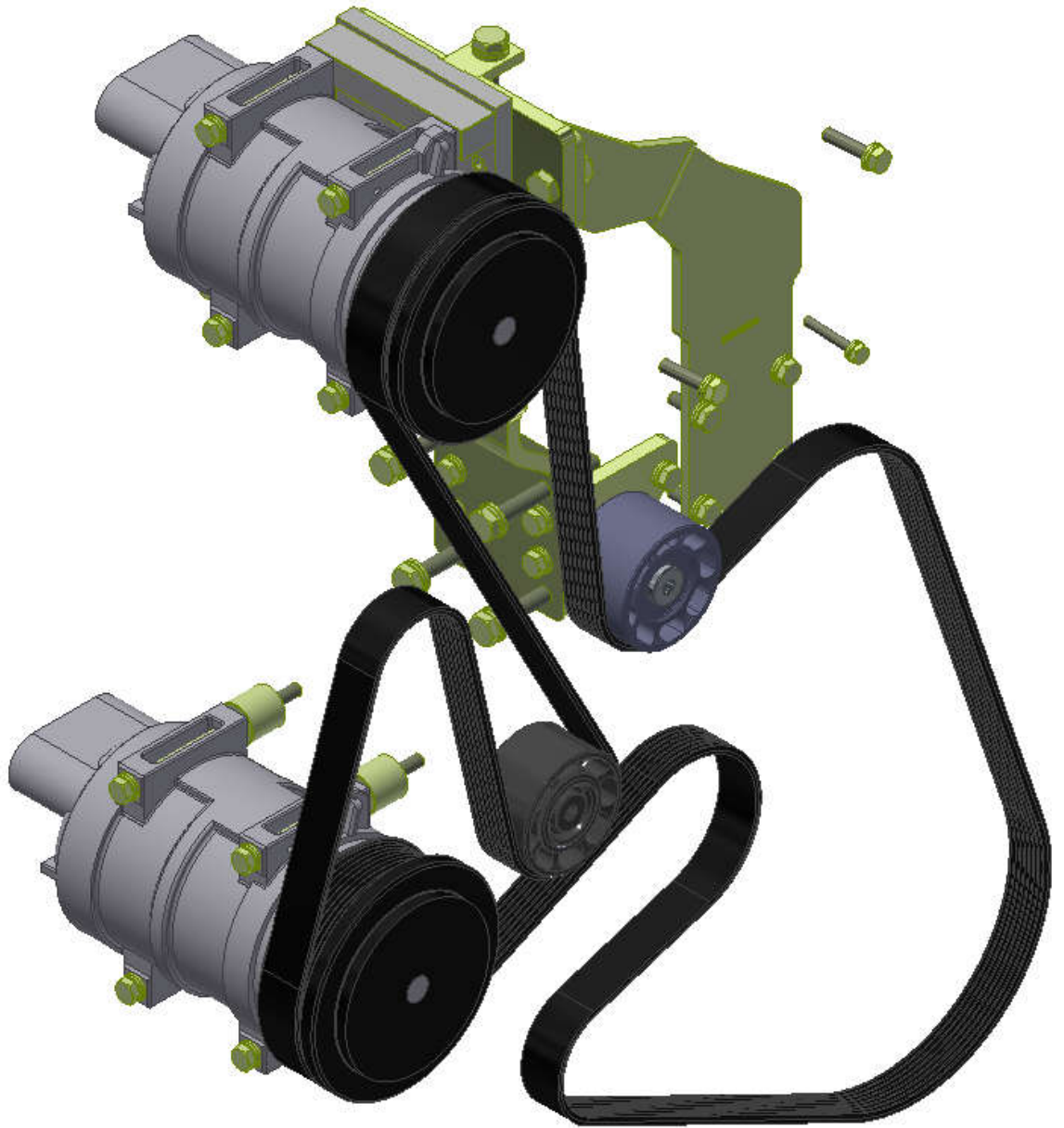

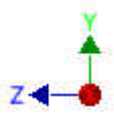
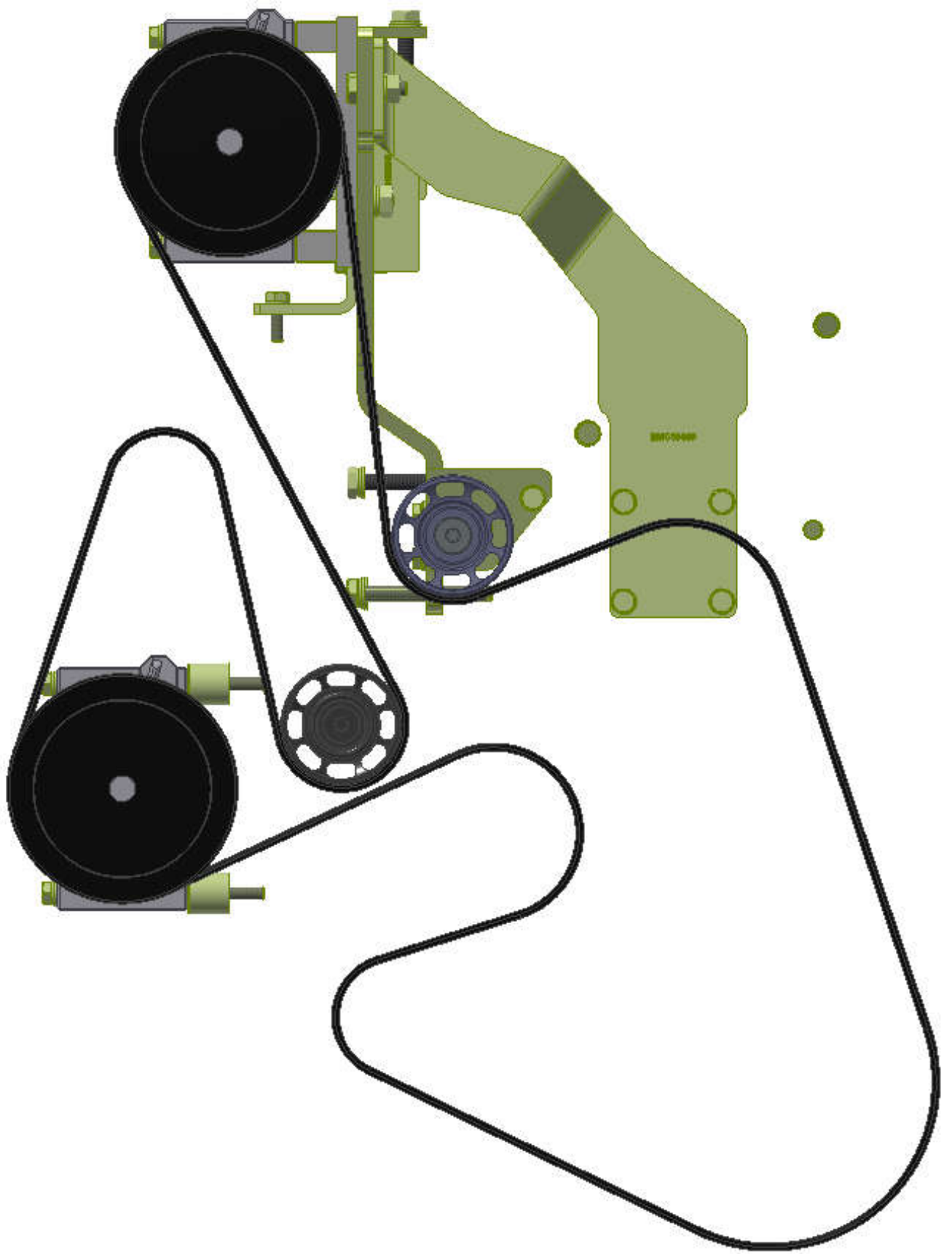

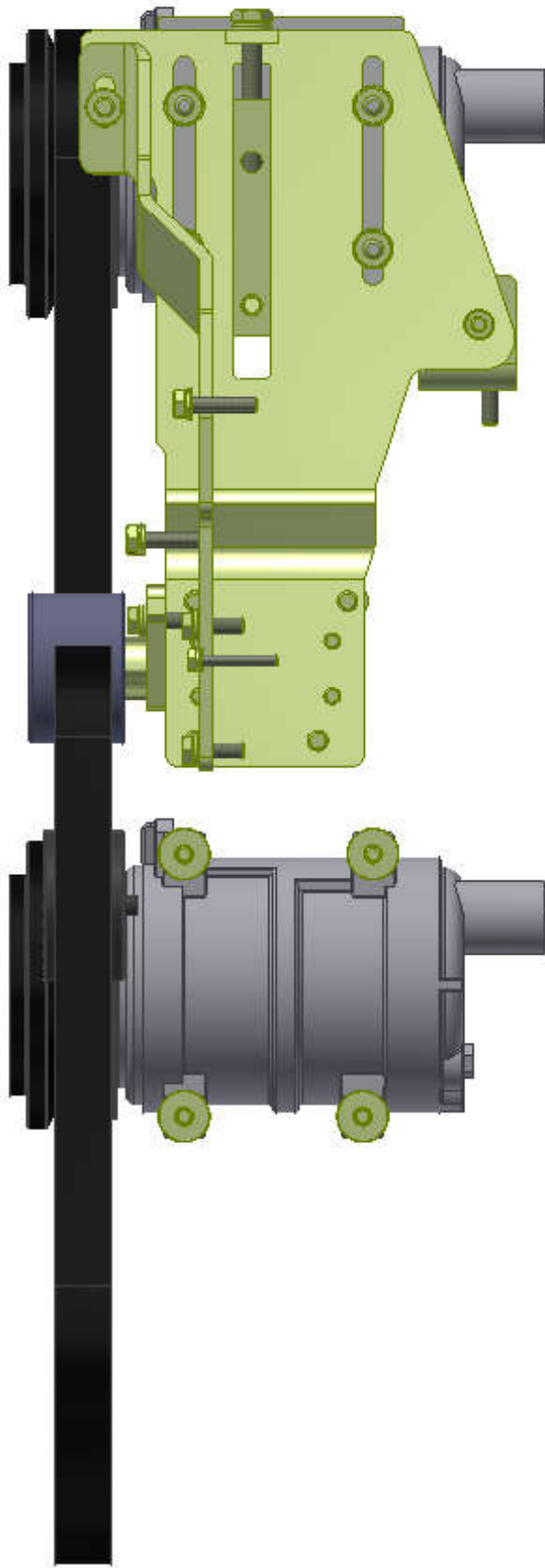
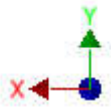

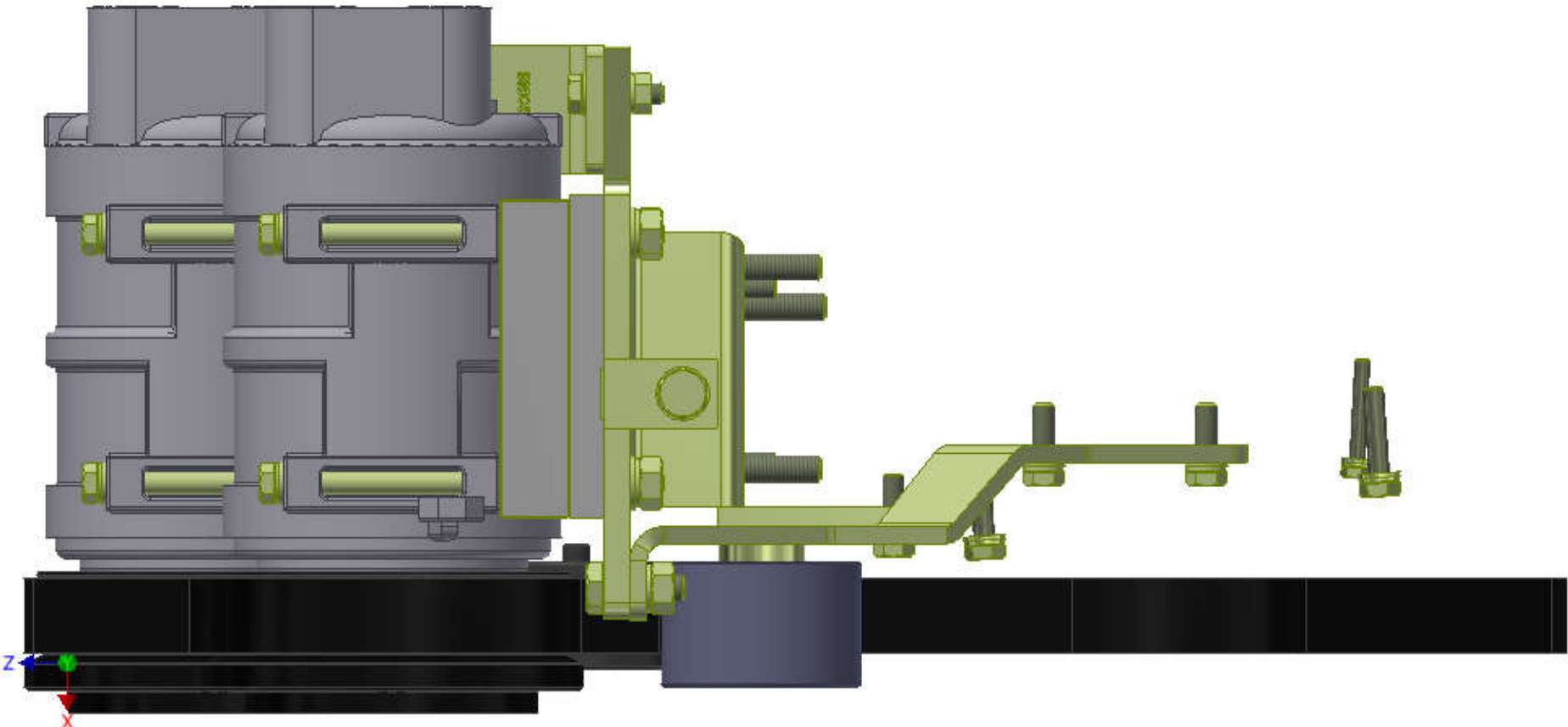

ON -
NOT MOVE BUS
WITH LIFT DOWN

RELOCATE TEMP SENSOR FROM RESERVOIR TO 3/4" LINE BELOW. (AS REQUIRED.)

CUT THE OEM C.A.TUBE IN HALF TO SUIT NEW ORIENTATION.
NOTE: INSURE THAT THE MODIFIED C.A.TUBE IS PROPERLY PREPED & CLEANED.

ROTATE TUBE SECTIONS TO SUIT NEW C.A. TUBE ORIENTATION.

NEW BRACKET (BMC67061) TO RELOCATE C.A. TUBE CLAMP.

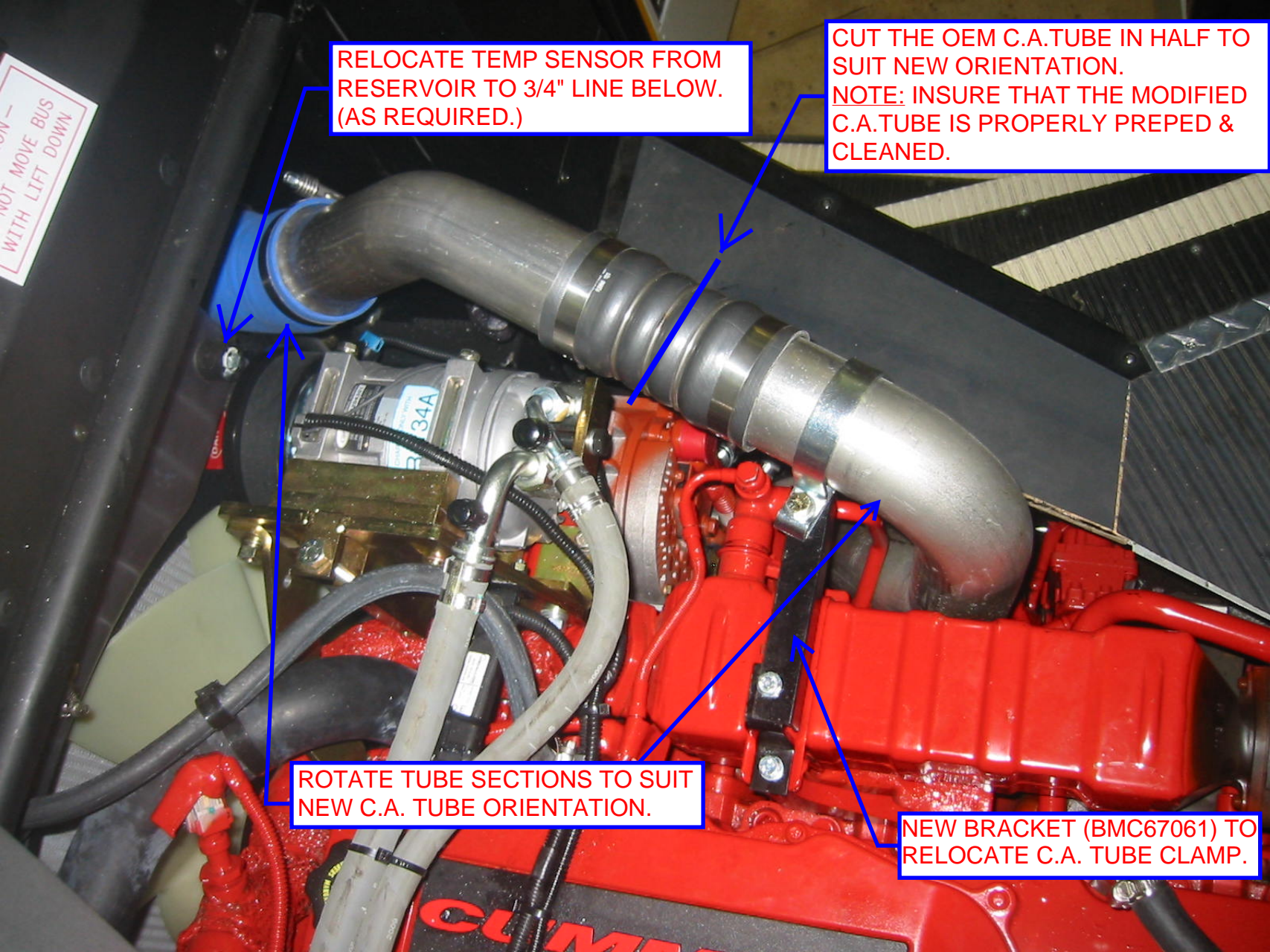

MAGI34

GP101E

GP110EB-M

PLUG V (S3621-6) IS LOOSE.
USED TO PLUG THE OLD SENSOR PORT POSITION IN THE RESERVOIR.

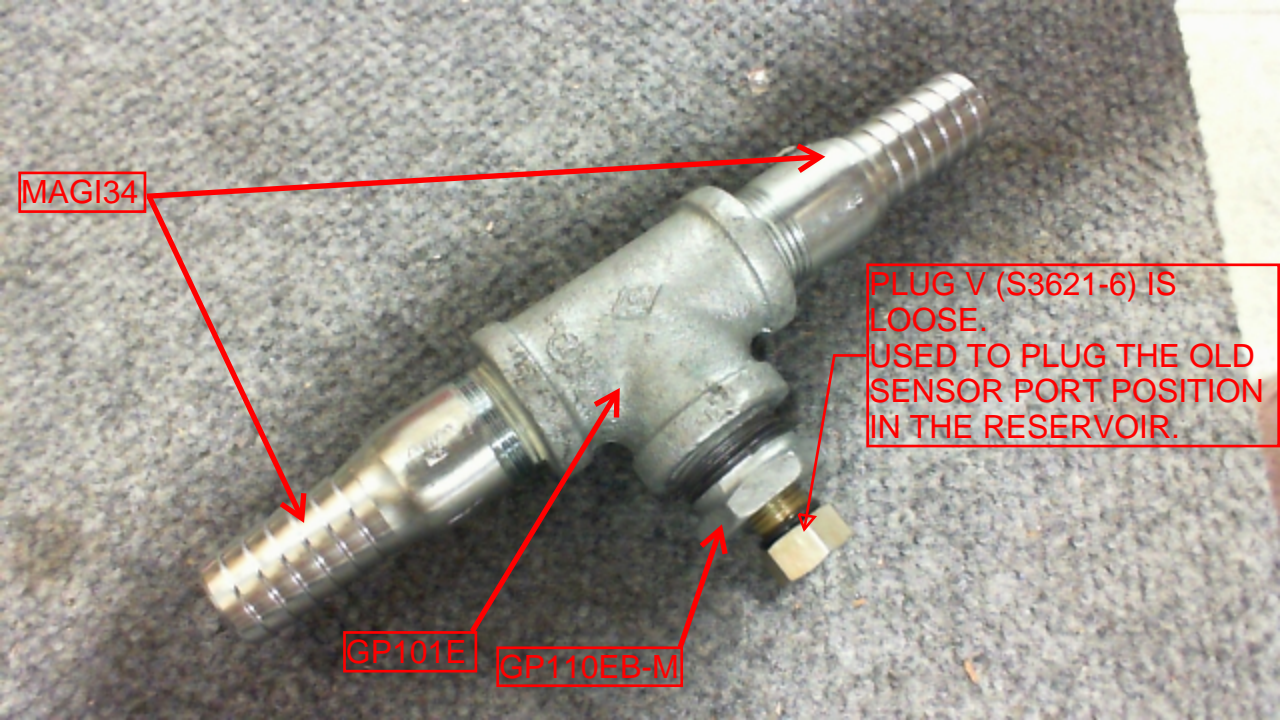

TransArctic A/C Compressor Mount Installation Disclaimer

All compressor mounts should be installed by qualified and trained personnel using proper tools and equipment in safe working conditions following industry standard guidelines for motor vehicle service and repair.

The installer of any compressor mount purchased from TransArctic must undertake all responsibility of issues arising from that compressor bracket being installed on any vehicle. As well as insure that a **proper and sufficient ground** is established between the compressors' clutches and the vehicle's engine. Mount functionality, operation and durability can all be compromised by an incompetent installation.

Due to the many different situations, parameters and application criteria, which are beyond the compressor mount manufacturer's control, TransArctic does not warrant design, durability, or operational functionality of any compressor mount improperly installed by another party.

With no implied guarantees it is the mount installer's strict responsibility to determine safety and functionality, of the compressor mount, at the time of installation.

Please contact TransArctic with any issue arising from installation so we may better improve the product. If you have any reservations about the compressor mount integrity contact TransArctic immediately at 1-877-COLD-AIR.

Mark OEM tensioner location

Install Kit

Check for Interferences

Check to ensure that the proper OEM tensioner orientation is maintained

Run engine with A/C system engaged for at least 10 minutes to run in belt

Check OEM tensioner orientation and adjust as required

Responsabilidad limitada de TransArctic en la instalación del soporte del compresor

Todos los soportes de los compresores deben ser instalados por personas calificadas y entrenadas, usando para ello los equipos y herramientas necesarios para esta labor en buenas condiciones y según las normas y guías para el servicio y/o reparación de motores de vehículos.

El instalador de los soportes comprados en TransArctic asume toda la responsabilidad de cualquier problema que surga en el soporte del compresor al vehículo; de igual manera es responsable que el cable a tierra sea conectado entre el embrague del compresor y el motor del vehículo.

Se advierte que el buen funcionamiento y la durabilidad del soporte pueden ser comprometidos por defectos en su instalación.

Debido a las diversas situaciones que se puedan presentar fuera del control del fabricante, TransArctic no garantiza el diseño, la durabilidad o el correcto funcionamiento de cualquier equipo inapropiadamente instalado por terceros.

Esta sobreentendido que el Instalador del montaje del compresor es estrictamente responsable de la seguridad y funcionamiento del equipo en el momento de la instalación.

Si tuviera algún problema o duda acerca de la instalación del soporte del compresor pongase en contacto inmediatamente con TransArctic al teléfono 1-877-COLD-AIR de modo que podamos mejorar nuestro producto.

Note la ubicación del medidor de tensión OEM

Instale el equipo

Controlar si hay interferencias.

Asegure que el medidor de tensión mantenga la orientación justa.

Encienda el motor por lo menos 10 minutos con el sistema A/C enganchado para que la correa corra

Controle la orientación justa del medidor de tensión y ajuste a las condiciones requeridas del fabricante