

Carrier  
Transicold  
Transport  
Air Conditioning

# SPLIT-SYSTEMS

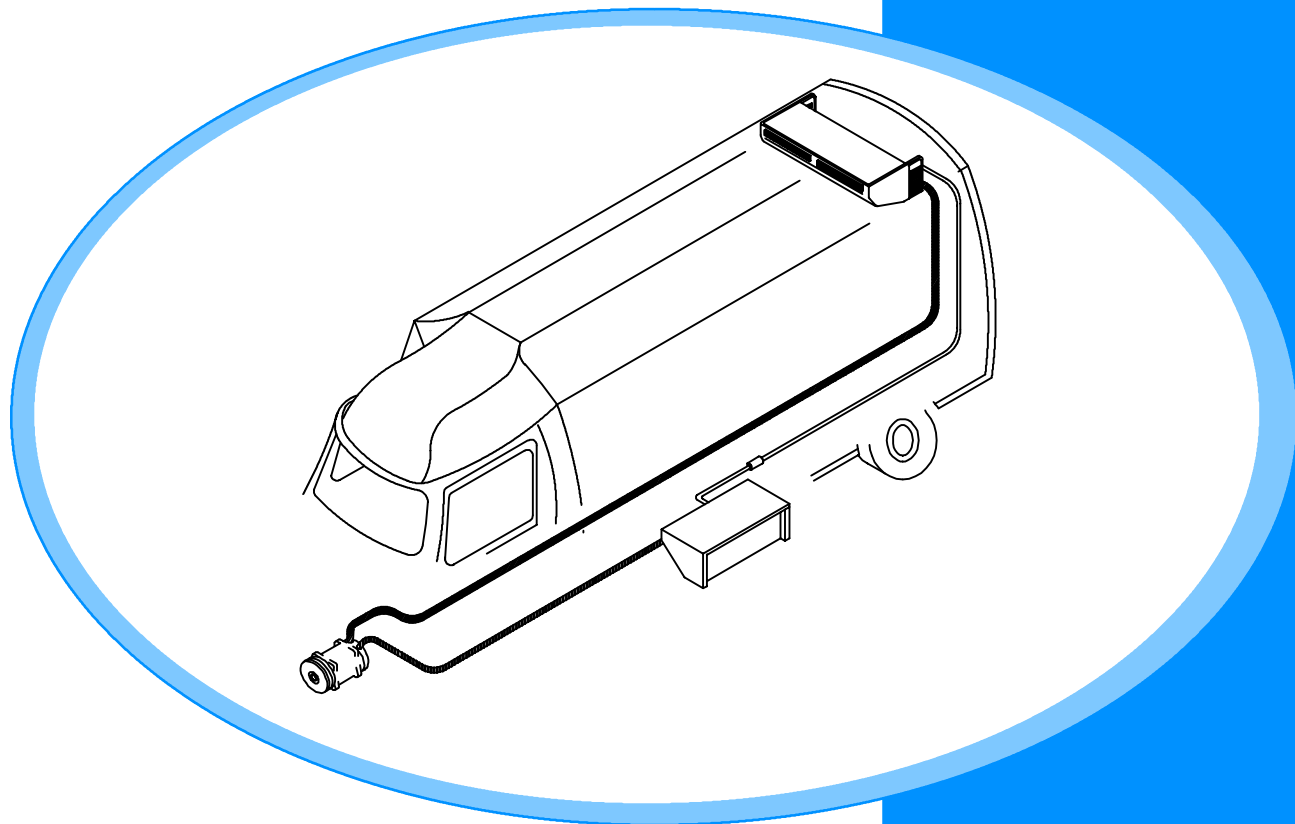

## Installation Procedures



**TRANSICOLD**

# INSTALLATION MANUAL

## Split-Systems

### POLICY AND PROCEDURES

Carrier Transport Refrigeration and Air Conditioning,  
A member of the United Technologies Corporation family. Stock symbol UTX.  
Carrier Transicold, Carrier Corporation, P.O. Box 4805, Syracuse, N.Y. 13221 U. S. A.

© 2003 Carrier Corporation D Printed in U. S. A. 1103



**Carrier**

A United Technologies Company

# SAFETY SUMMARY

## GENERAL SAFETY NOTICES

The following general safety notices supplement the specific warnings and cautions appearing elsewhere in this manual. They are recommended precautions that must be understood and applied during installation, operation, service, and maintenance of the equipment covered herein. The general safety notices are presented in the following three sections labeled: First Aid, Operating Precautions and Installation Precautions. A listing of the specific warnings and cautions appearing elsewhere in the manual follows the general safety notices.

## FIRST AID

An injury, no matter how slight, should never go unattended. Always obtain first aid or medical attention immediately.

## OPERATING PRECAUTIONS

Always wear protective eye wear (safety glasses or goggles).

Keep hands, clothing and tools clear of the evaporator and condenser fans.

No work should be performed on the system unless battery power is disconnected.

Always work in pairs. Never work on the equipment alone.

In case of severe vibration or unusual noise, stop the system and investigate.

When vehicle engine is running, keep your hands, clothing and tools clear of the engine fan blade and drive belts.

## INSTALLATION PRECAUTIONS

Familiarize yourself with the proper operation of any service equipment you will be using (voltmeter, amp probe, manifold gauges, etc.). Always read the owner's manual that is enclosed with the equipment

Always follow the manufacturers instructions for your recovery/recycling equipment. Failure to do so could cause personal injury or damage to your equipment. Never perform any maintenance or service on your equipment before consulting with authorized service personnel. Always unplug unit before attempting any maintenance. Removing internal fittings and filters can release pressurized refrigerant. Slowly release pressure and always wear appropriate safety wear.

Avoid breathing any refrigerant vapor, lubricant vapor, or mist. Exposure to these, particularly PAG oil mist, may irritate your eyes, nose, or throat.

Always use a DOT (Department of Transportation) approved cylinder for storing used and recycled refrigerant. Approved cylinders will be stamped DOT 4BW or DOT 4BA. Carrier recommends a MACS (Mobile Air Conditioning Society) certification in Recovery/Recycling to gain more information on handling and using refrigerants.

Never attempt to apply heat or open flame to a refrigerant cylinder. High temperatures can raise the cylinder pressure to dangerous levels. Carrier recommends using a heat blanket to increase the internal temperature of the refrigerant cylinder, greatly increasing the rate of transfer of refrigerant to the bus air conditioning system.

Never use compressed air (shop-air) to leak-test or pressure test a R134a system. Under certain conditions, pressurized mixtures of R134a and air can be combustible. In addition, shop air will inject moisture into the system.

Always use mineral oil to lubricate "O" Rings, hoses, and fittings on R134a systems. PAG oils will absorb moisture and become very acidic and corrosive. Mineral oil will not absorb moisture and thus prevent corrosion. Always wear gloves when working with PAG and Ester lubricants to prevent irritation to your skin. R134a lubricants can also damage vehicles paint, plastic parts, engine drive belts and coolant hoses.

Beware of unannounced starting of the evaporator and condenser fans. Do not remove the evaporator cover or condenser fan guards without disconnecting the vehicle battery cable.

Always wear gloves when handling evaporators and condensers.

Be sure power is turned off before working on motors, controllers, and electrical control switches. Tag system controls and vehicle battery to prevent accidental energizing of the system.

Do not bypass any electrical safety devices, e.g. bridging an overload, or using any sort of jumper wires. Problems with the system should be diagnosed, and any necessary repairs performed, by qualified service personnel.

When performing any arc welding on the vehicle, disconnect the vehicle battery.

In case of electrical fire, extinguish with CO<sub>2</sub> (never use water). Disconnect vehicle battery power if possible.

Never route hoses or electrical harnesses down the front of the bus on the driver's side when installing a front mounted evaporator assembly. Driver visibility could be impaired.

Before drilling holes for routing hoses and harnesses through the bus floor or wall, make sure there are no electrical harnesses, floor braces, tubing, etc. in the path of the holes to be drilled. Drilling into an electrical harness or fuel line could cause a fire or explosion.

## SPECIFIC WARNINGS AND CAUTIONS

### WARNING

Beware of unannounced starting of the evaporator and condenser fans. The unit may cycle the fans and compressor unexpectedly as control requirements dictate.

### WARNING

Do not attempt to modify the EM-3 evaporator top panel. Modifications to the top panel could structurally weaken the evaporator assembly, causing system failures and/or injuries to passengers.

### WARNING

Do not use a nitrogen cylinder without a pressure regulator

### WARNING

Do not use oxygen in or near a refrigeration system as an explosion may occur.

### WARNING

Be sure to observe warnings listed in the safety summary in the front of this manual before performing maintenance on the air conditioning system

### WARNING

Never use air for leak testing. It has been determined that pressurized, air-rich mixtures of refrigerants and air can undergo combustion when exposed to an ignition source.

### CAUTION

When selecting a location for installing the evaporator it is highly recommended that two roof bows are used to secure the mounting rails.

### CAUTION

Make sure there is nothing installed where you are going to drill through the bus floor.

### CAUTION

This condenser assembly must contact the bus roof in the center. If not, damage will occur. Consult factory as optional mounting may be required.

### CAUTION

All 3/16 and 1/4 In. rivet engagement thickness (grip range) must be between 0.080 and 0.625. Using rivets other than those specified may allow the condenser assembly to come loose from the bus roof.

### CAUTION

It must be emphasized that only the correct refrigerant cylinder should be connected to pressurize the system. Any other gas or vapor will contaminate the system, which will require additional evacuations.

### CAUTION

When drilling into the vehicle wall, always use a drill stop to help protect against damaging any wiring that might be located behind the wall.

### CAUTION

Never substitute fittings or hose. Follow the piping diagram provided with the system.

## SPECIFIC WARNINGS AND CAUTIONS; Continued

### CAUTION

Tie-Wraps may be used to bundle hoses and harnesses, but should never be used to secure hoses to the vehicle.

### CAUTION

Use only the exact oil specified by the compressor manufacturer. Use of oil other than that specified will void the compressor warranty.

### CAUTION

Condenser assemblies must be properly installed using graded hardware. The CM-2 condenser assembly requires at least 4 bolts and the CM-3 requires at least 6 bolts.

### CAUTION

No matter what type of lubricant (oil) used in the system, always use mineral oil to lubricate the O-Rings, and fittings. PAG oils will absorb moisture and become very acidic and corrosive. Mineral oil will not absorb moisture and thus prevent corrosion.

### CAUTION

Always use existing holes in the chassis frame. Never drill holes in the chassis frame.

### CAUTION

Never secure hoses or harnesses to any part of the vehicle fuel system.

### CAUTION

Always use existing holes in the chassis frame. Never drill holes in the chassis frame.

### CAUTION

Verify that the oil added to the air conditioning system is the same oil that is in the compressor. The mixing of incompatible oils will possibly damage your system.

### CAUTION

To prevent trapping liquid refrigerant in the manifold gauge set be sure manifold gauge set is brought to suction pressure before disconnecting.

# TABLE OF CONTENTS

Section .....	Page
<b>SAFETY SUMMARY .....</b>	<b>i</b>
SPECIFIC WARNINGS AND CAUTIONS .....	ii
<b>DESCRIPTION .....</b>	<b>1-1</b>
1.1 INTRODUCTION .....	1-1
1.2 WHAT IS AIR CONDITIONING .....	1-1
1.3 SYSTEM NOMENCLATURE DESIGNATIONS .....	1-1
1.3.1 Model And Serial Number Tags .....	1-1
1.3.2 System Requirements Label .....	1-1
1.4 SYSTEM COMPONENTS .....	1-3
1.5 COOLING CYCLE .....	1-4
1.6 EVAPORATORS .....	1-6
1.7 CONDENSERS .....	1-7
1.8 PRE-INSTALLATION INSPECTION .....	1-7
<b>EVAPORATORS .....</b>	<b>2-1</b>
2.1 INTRODUCTION .....	2-1
2.1.1 Description .....	2-1
2.1.2 Location .....	2-1
2.1.3 Cap Plugs .....	2-1
2.1.4 Blower Wheels .....	2-1
2.1.5 Aesthetics .....	2-1
2.1.6 Mounting (Front & Rear) .....	2-1
2.1.7 Mounting (Side) .....	2-1
2.1.8 Drain Lines .....	2-1
2.1.9 Ducted Systems .....	2-1
2.1.10 Bus Headliners .....	2-1
2.1.11 Mounting Hardware .....	2-1
2.2 REAR MOUNTED EVAPORATORS .....	2-2
2.2.1 GEN 4/5 Series EM-1, EM-2, EM-3, EM-7, EM-6, & EM-14 .....	2-2
2.2.2 EM-3 EVAPORATOR GEN 4 OR GEN 5 .....	2-7
2.3 SIDE MOUNTED EVAPORATOR - EM-1, EM-2, EM-6, EM-7, & EM-14 .....	2-9
2.4 EM-9 DUCTED EVAPORATOR .....	2-12
2.5 EM-17 EVAPORATOR .....	2-15
2.6 IW-1, IW-2, IW-7 & IW-14 EVAPORATORS .....	2-15
2.7 EM-20, EM-21 & EM-22 EVAPORATORS .....	2-15
<b>CONDENSERS .....</b>	<b>3-1</b>
3.1 INTRODUCTION .....	3-1
3.1.1 Description .....	3-1
3.1.2 Location .....	3-1
3.1.3 Cap Plugs .....	3-1
3.1.4 Protection .....	3-1
3.1.5 Obstructions .....	3-1
3.1.6 Skirt Supports .....	3-1
3.1.7 Mounting (Skirt) .....	3-1
3.1.8 Mounting (Rooftop) .....	3-1
3.1.9 Voltage .....	3-1

## TABLE OF CONTENTS - Continued

Section	Page	
3.2	CONDENSERS	3-2
3.3	CM-2, CM-3, CM-4, CM-5, & CM-14 SKIRTMOUNTED CONDENSER ASSEMBLIES	3-2
3.4	Cm-5 CONDENSER	3-5
3.5	Cm-7, CM-11 ROOFTOP CONDENSER ASSEMBLIES	3-6
3.5.1	Connecting to Side-Mounted Evaporators	3-8
3.6	KR-4 ROOFTOP CONDENSER ASSEMBLY	3-10
3.6.1	Connecting To The Evaporators	3-11
3.7	CM-2 AND CM-3 STACKED CONDENSER ASSEMBLIES	3-12
<b>HOSE ROUTING</b>		<b>4-1</b>
4.1	INTRODUCTION	4-1
4.1.1	Planning	4-1
4.1.2	Service Loop	4-1
4.1.3	Dual Systems	4-1
4.1.4	Connection Lubrication (Mineral Oil)	4-1
4.1.5	Quick-Click Hose & Clamps	4-1
4.1.6	Barrier Type Hose & Fittings	4-1
4.2	EVAPORATOR HOSE ROUTING-INSIDE THE BUS WALL	4-1
4.3	EVAPORATOR HOSE ROUTING, OUTSIDE THE BUS WALL	4-5
4.4	EVAPORATOR HOSE ROUTING, SIDE-MOUNTED	4-5
4.5	CHASSIS HOSE ROUTING	4-6
4.6	CONDENSER HOSE ROUTING	4-7
4.7	VEHICLE COMPRESSOR HOSE ROUTING	4-8
4.8	TORQUE SPECIFICATIONS - REFRIGERANT FITTINGS	4-8
4.9	ROOFTOP CONDENSER HOSE ROUTING (CM-7 & CM-11)	4-9
4.10	AUXILIARY HEATER HOSE ROUTING (GENERIC)	4-9
4.11	PIPING DIAGRAMS	4-9
<b>ELECTRICAL</b>		<b>5-1</b>
5.1	INTRODUCTION	5-1
5.2	SYSTEM WIRING	5-1
5.2.1	Electrical Kits	5-1
5.2.2	Protection	5-1
5.2.3	Dual Systems	5-1
5.3	VOLTAGES	5-1
5.4	Component Connections	5-1
5.4.1	Evaporator Chassis Ground, Gen 4 (Excel)	5-1
5.4.2	Evaporator Chassis Ground, Gen 5	5-2
5.5	CONTROLS	5-2
5.5.1	Manual controls	5-2
5.5.2	Electrical Control Panel	5-3
5.6	TOTAL CONTROL	5-3
5.6.1	Total Control Electrical Control Panel	5-3
5.7	OPERATING INSTRUCTIONS	5-4

## TABLE OF CONTENTS - Continued

Section .....	Page
<b>MOUNT KITS AND COMPRESSORS .....</b>	<b>6-1</b>
6.1 INTRODUCTION .....	6-1
6.2 INSTALLATION .....	6-1
6.2.1 TORQUE SPECIFICATIONS .....	6-2
6.3 DRIVE BELT INSTALLATION .....	6-2
6.3.2 Belt Clearance .....	6-2
6.3.3 Pulley Alignment .....	6-3
6.3.5 Measuring Methods for Belt Tension .....	6-4
6.4 COMPRESSOR INSTALLATION .....	6-4
6.4.1 Installation Position .....	6-4
6.4.2 Installation Precautions .....	6-4
6.4.3 Mounting Compressors .....	6-4
6.4.4 Oil Charge .....	6-5
<b>EVACUATION .....</b>	<b>7-1</b>
7.1 INTRODUCTION .....	7-1
7.2 REFRIGERANT SERVICE TOOLS .....	7-1
7.2.1 Preparation .....	7-1
7.2.2 Procedure - Complete system .....	7-1
7.3 INSTALLING MANIFOLD GAUGES .....	7-2
<b>CHARGING PROCEDURES .....</b>	<b>8-1</b>
8.1 . INTRODUCTION .....	8-1
8.1.1 . Proper R134a Charge .....	8-1
8.1.2 . Proper Oil Charge .....	8-1
8.1.3 . Liquid Charging .....	8-1
8.1.4 . PAG And POE Oils .....	8-1
8.1.5 . Evaporator Tie-In .....	8-2
8.1.6 . Adding Refrigerant to System (Full Charge) .....	8-2
<b>LEAK CHECKING .....</b>	<b>9-1</b>
9.1 INTRODUCTION .....	9-1
9.1.1 Micron (Vacuum) Gauge .....	9-1
9.1.2 Nitrogen .....	9-1
9.2 REFRIGERANT LEAK CHECKING .....	9-1
<b>WARRANTY REGISTRATION .....</b>	<b>10-1</b>
10.1 INTRODUCTION .....	10-1
10.2 PROCEDURES .....	10-1
10.3 WARRANTY POLICY .....	10-1
10.3.1 In-Line Failures - OEM/Installer Repair .....	10-1
<b>FINAL (CHECK-OUT SHEET) .....</b>	<b>11-1</b>
INSTALLATION CHECK-OUT .....	11-1
11.1 SYSTEM REQUIREMENTS LABEL .....	11-5
11.1.1 System Requirement Label Completion .....	11-5



## LIST OF ILLUSTRATIONS

Figure .....	Page
Figure 1-1 Condenser Model – Serial Number Location .....	1-2
Figure 1-2 GEN 4 Evaporator Model – Serial Number Location .....	1-2
Figure 1-3 GEN 5 Evaporator Model – Serial Number Location .....	1-3
Figure 1-4 CM-7/11 Rooftop Condensers – Serial Number Location .....	1-3
Figure 1-5 Refrigerant Flow and Typical Component Locations .....	1-4
Figure 1-6 Refrigerant Flow Diagram .....	1-5
Figure 2-1 Template For EM-1 And EM-2 (GEN 4) .....	2-2
Figure 2-2 Measurement To Wall (GEN 4) .....	2-3
Figure 2-3 Measurement To Wall (GEN 5) .....	2-3
Figure 2-4 7/16 Inch Holes in Bus Roof .....	2-3
Figure 2-5 Carriage Bolts & Sealant .....	2-3
Figure 2-6 Sealant Pattern on Mounting Channel .....	2-3
Figure 2-7 Carriage Bolt Sealing .....	2-4
Figure 2-8 Locking Pliers Clamped to Carriage Bolts .....	2-4
Figure 2-9 Locking Pliers & Evaporator .....	2-4
Figure 2-10 Evaporator Mounted to Flat Ceiling .....	2-4
Figure 2-11 Mounting Channel Sealing .....	2-4
Figure 2-12 Block Valve Insulation .....	2-5
Figure 2-13 Drain line & Condensate Valve .....	2-5
Figure 2-14 Installed Evaporator .....	2-5
Figure 2-15 Return Air Grill .....	2-5
Figure 2-16 Painted Mounting Channel .....	2-6
Figure 2-17 GEN-4/5 Front/Rear (EM-1, 2, 6, & 14) Evaporator & Installation Hardware .....	2-6
Figure 2-18 Rear Mount Evaporator – Installed .....	2-7
Figure 2-19 EM-6 Rear Mounted In An Extended Roof Van .....	2-7
Figure 2-20 EM-3 Installation Diagram .....	2-8
Figure 2-21 Side-Mount Template .....	2-9
Figure 2-22 Drain Line Elbows .....	2-9
Figure 2-23 Side Mount Installation Instructions (Typical) .....	2-10
Figure 2-24 Side Mounted Evaporator GEN 4 .....	2-10
Figure 2-25 EM-2 (Gen V) Side-Mount – Free Blow, Installed (Complete) .....	2-11
Figure 2-26 EM-9 Ducted Evaporator – Hose & Harness Routing .....	2-12
Figure 2-27 Punching out Louver Holes .....	2-13
Figure 2-28 End Cap With Louver .....	2-13
Figure 2-29 EM-9 Ducted Evaporator – Location – Completed Assembly .....	2-13
Figure 2-30 School Style Ducting–Passenger Side .....	2-13
Figure 2-31 School Style Ducting–Drivers Side .....	2-13
Figure 2-32 Side Mounted Hose Routing (Using 455 Angles) .....	2-14
Figure 2-33 Side Mounted Hose Routing (Straight) .....	2-14
Figure 2-34 EM-17 INSTALLED .....	2-15
Figure 3-1 3/8 Inch Carriage Bolts Thru Floor .....	3-3
Figure 3-2 Condenser Mounted With Hardware .....	3-3
Figure 3-3 Installation Drawing (Typical Skirt Mounted) .....	3-3
Figure 3-4 CM-3 Condenser Mounting (Typical) .....	3-4
Figure 3-5 CM-2 Condenser Mounted on an Extended Roof Van (Custom) .....	3-4

## LIST OF ILLUSTRATIONS - Continued

Figure .....	Page
Figure 3-6 CM-3 Mounted In Cut-A-Way Chassis .....	3-4
Figure 3-7 CM-5 Installation Drawing .....	3-5
Figure 3-8 Installing Mounting Feet & Mounting Channels .....	3-6
Figure 3-9 Attaching To Feed-Thru-Plate & Remote Filter Drier .....	3-6
Figure 3-10 Attaching Mounting Channels To Bus Roof .....	3-7
Figure 3-11 Adjusting Mounting Foot Height .....	3-7
Figure 3-12 Hose Cover Transition Cut-Outs .....	3-8
Figure 3-13 Hose Cover Transition & Refrigerant Hose Connections .....	3-8
Figure 3-14 Mounting Options .....	3-10
Figure 3-15 Condenser Mounted Without Mounting Channels .....	3-11
Figure 3-16 Condenser Mounted With Mounting Channels .....	3-11
Figure 3-17 Condenser Mounted Without Mounting Channels (Side View) .....	3-11
Figure 3-18 Condenser Mounted With Mounting Channels (Side View) .....	3-11
Figure 3-19 Stacked Condenser Assembly (Side View) .....	3-12
Figure 3-20 Stacked Condenser Assembly (Bus Skirt View) .....	3-13
Figure 4-1 Quick-Click Hose (Capped) .....	4-1
Figure 4-2 Bus With Rear Seat Removed .....	4-1
Figure 4-3 Hose Back Positioning .....	4-2
Figure 4-4 Hole-Saw Cuts in Floor .....	4-2
Figure 4-5 Hole-Saw Cuts Joined .....	4-2
Figure 4-6 Rear Wall Access .....	4-2
Figure 4-7 Hose Cover Back .....	4-3
Figure 4-8 Hose Cover Backs On Rear Wall .....	4-3
Figure 4-9 Access Hole With Trim-Lock .....	4-3
Figure 4-10 Hoses Routed Through Access .....	4-3
Figure 4-11 Hoses Routed Through Floor .....	4-4
Figure 4-12 Hoses/Harness Secured With Tie-Wraps To Hose Cover Back .....	4-4
Figure 4-13 Hose/Harness Clamped to Wall .....	4-5
Figure 4-14 Hose Cover Backs W/Tie-Wraps .....	4-6
Figure 4-15 Hose Routing (Chassis) .....	4-7
Figure 4-16 Hose Routing (Chassis) .....	4-7
Figure 4-17 Hose Routing (Chassis) .....	4-7
Figure 4-18 Hose Routing (Chassis) .....	4-7
Figure 4-19 Hose Routing (Chassis & Condenser) .....	4-7
Figure 4-20 Engine Routing (With High & Low In-Line Access Fittings) .....	4-8
Figure 4-21 Hose Routing - OEM (To & From Engine) .....	4-8
Figure 4-22 Rear Evaporator OEM Tie-In .....	4-10
Figure 4-23 Evaporator, Skirt Mounted Condenser, and Compressor .....	4-11
Figure 4-24 Evaporator, Skirt Mounted Condenser and Compressor (AC-322, -332, -442) .....	4-12
Figure 4-25 Evaporator, Skirt Condenser, Compressor, and Aftermarket In-Dash (AC-4431) .....	4-13
Figure 4-26 EM-3 Evaporator, (2) Skirt Condensers, and TM-31 Compressor (AC-882, -883) .....	4-14
Figure 4-27 (1) EM-3 Evap., (1) EM-7 Evap., (2) Skirt Condensers, & (1) TM-31 Comp. (AC-9632) .....	4-15
Figure 5-1 Harness & Pig-Tail Connections .....	5-1
Figure 5-2 Grounded to Clamp .....	5-2
Figure 5-3 Grounded to Chassis Rail .....	5-2

## LIST OF ILLUSTRATIONS - Continued

Figure .....	Page
Figure 5-4 Drivers Control Panel .....	5-2
Figure 5-5 Controls Mounted Without Panel .....	5-2
Figure 5-6 Drivers Control Panel (Dual Systems) .....	5-3
Figure 5-7 Electrical Control Panel (Typical) .....	5-3
Figure 5-8 Total Control Key Pad/Display .....	5-3
Figure 5-9 Total Control Electrical Panel (Typical) .....	5-4
Figure 5-10 Gen 5 Total Control (Dual System) .....	5-4
Figure 6-1 Metric Torque Specs .....	6-2
Figure 6-2 Metric Bolt Markings .....	6-2
Figure 6-3 U.S.S. Torque Specs .....	6-2
Figure 6-4 U.S.S. Bolt Markings .....	6-2
Figure 6-5 Belt Clearance Requirements .....	6-3
Figure 6-6 Belt Misalignment .....	6-3
Figure 6-7 Straight-Edge Application .....	6-3
Figure 6-8 Belt Tension Guide .....	6-4
Figure 6-9 Compressor Mounting Angles .....	6-5
Figure 7-1 Manifold Gauge Set .....	7-2
Figure 7-2 Refrigerant Service Connections (Split Systems) .....	7-3
Figure 9-1 Refrigerant Service Connections (Split Systems) .....	9-2
Figure 10-1 Warranty Registration Card .....	10-1
Figure 11-1 System Requirements Label .....	11-5

## LIST OF TABLES

Table .....	Page
Table 1-1 ADDITIONAL SUPPORT MANUALS .....	1-1
Table 1-2 CARRIER TRANSPORT AIR CONDITIONING SYSTEMS (GEN 4/5) .....	1-2
Table 1-3 GEN 4 EVAPORATORS .....	1-6
Table 1-4 GEN 5 EVAPORATORS .....	1-6
Table 1-5 CONDENSERS (Used With GEN 4 And GEN 5 Series) .....	1-7
Table 2-1 GEN 4 EVAPORATORS .....	2-2
Table 2-2 GEN 5 EVAPORATORS .....	2-2
Table 2-3 DISTANCE TO BACK WALL (GEN 4) .....	2-3
Table 2-4 DISTANCE TO BACK WALL (GEN 5) .....	2-3
Table 3-1 CONDENSERS (Used With GEN 4 And GEN 5 Series) .....	3-2
Table 3-2 SKIRT MOUNTED CONDENSERS .....	3-2
Table 8-1 SPLIT SYSTEM REFRIGERANT AND OIL CHARGING TABLE (THROUGH GEN 4) .....	8-1
Table 8-2 SPLIT SYSTEM REFRIGERANT AND OIL CHARGING TABLE (GEN 5) .....	8-2
Table 8-3 COMP. OIL TYPE & PART NUMBERS .....	8-2
Table 8-4 CARRIER TRANSPORT AIR CONDITIONING SYSTEM PERFORMANCE CHART .....	8-3

# SECTION 1

## DESCRIPTION

### 1.1 INTRODUCTION

This manual contains instructions for the proper preparation of and installation of Carrier Transport Air Conditioning split systems. This manual does not replace proper training and/or certification required by the EPA or other local agencies.

The purpose of this manual is to assist you in completing a quality, trouble-free installation which will compliment a quality product, and ensure optimum system performance for the life of the vehicle.

While this manual does not cover all combinations, variations, and details, it does set up standards from which installation processes can be measured.

Common sense and care for quality will result in superior installations and customer satisfaction.

A Split System normally includes an evaporator(s), a condenser(s) a compressor(s) and interconnecting refrigerant hoses, fittings, and electrical harnesses and controls. Refer to Table 1-3 & Table 1-4 for evaporator models and Table 1-5 for condenser models. Table 1-2 shows popular system designations. Additional support manuals are listed in Table 1-1.

When in doubt about a particular installation or if you require additional information, do not hesitate to call Carrier Transport Air Conditioning technical service Hot Line for assistance (800-450-2211).

### 1.2 WHAT IS AIR CONDITIONING

Air Conditioning is the cooling, dehumidification, and filtration of the air located within the passenger compartment of your vehicle.

### 1.3 SYSTEM NOMENCLATURE DESIGNATIONS

All Carrier Transport Air Conditioning split system applications will have system numbers consisting of 2 letters followed by 3 or more numbers (ie. AC-512), identifying them as a free blow or ducted system, approximate BTU rating, type of evaporator assembly and type of condenser assembly.

The letter "A" from the letters "AC" means this systems evaporator(s) are free blow units.

The letter "D" from the letters "DC" means this systems evaporator(s) are corner ducted.

The first number after the letters "AC" or "DC" is the capacity of the system in BTU's to the nearest 10 thousand. (Example - 26,000 BTU's would be rounded off to 30,000 BTU's, or the number 3.)

The second and third numbers designate the evaporator(s) assembly.

The fourth and fifth numbers designate the condenser(s) assembly.

When only three numbers are in the designation, the second number is the evaporator and the third number is the condenser. (Example - AC-512 = AC designates a free-blow system, 5 means approximately 50,000 BTU, 1 is an EM-1 evaporator assembly, while the 2 designates a CM-2 condenser assembly).

#### 1.3.1 Model And Serial Number Tags

In order to identify the air conditioning system you are installing, you will need to know the model number and serial number. All Carrier Transport Air Conditioning system components have a model and serial number data tag located on each evaporator and condenser assembly. See Figure 1-1 for skirt mounted condenser data tag location, Figure 1-2 for GEN 4 evaporator data tag location, Figure 1-3 for GEN 5 evaporator data tag location and Figure 1-4 for the CM-7 & CM-11 rooftop condensers data tag location. Knowing these locations and the information on the data tags will aid you in completing the Warranty Registration Card (refer to Section 10), and if needed, ordering the correct replacement parts.

#### NOTE

The EM-9 evaporator data tag is located on the side of the evaporator assembly, not between the blower assemblies.

#### 1.3.2 System Requirements Label

The system requirements label (See Figure 11-1) is filled out after the installation and is affixed as close to the vehicle compressor as possible. Refer to paragraph 11.1 for instruction on completing the system requirements label.

**Table 1-1 ADDITIONAL SUPPORT MANUALS**

MANUAL NUMBER	EQUIPMENT COVERED	TYPE OF MANUAL
T-299	Split Systems	Operation & Service
T-299PL	Split Systems	Parts List
62-10686	Split Systems	Installation Video
62-50455	Basic Refrigeration	Service Training
62-50468	Transport Refrigeration	Service Training
62-03213	Service Tools	Service Tools
62-02737	Transport Air Conditioning	Warranty Policy & Procedures

Table 1-2 CARRIER TRANSPORT AIR CONDITIONING SYSTEMS (GEN 4/5)

SYSTEM	TYPE	BTU	EVAP (S)	COND (S)	COMP (S)
AC-3140	FB	26,000	(1) EM-14	OEM	OEM
AC-360	FB	30,000	(1) EM-6	OEM	OEM
AC-3142	FB	26,000	(1) EM-14	(1) CM-2	(1) 10 CID
AC-362	FB	30,000	(1) EM-6	(1) CM-2	(1) 10 CID
AC-422	FB	40,000	(1) EM-2	(1) CM-2	(1) 10 CID
AC-512	FB	48,000	(1) EM-1	(1) CM-2	(1) 10 CID
AC-513	FB	52,000	(1) EM-1	(1) CM-3	(1) 10 CID
AC-633	FB	60,000	(1) EM-3	(1) CM-3	(1) 12.6 CID
AC-8322	FB	78,000	(1) EM-3	(2) CM-2	(2) 10 CID
AC-82222	FB	80,000	(2) EM-2	(2) CM-2	(2) 10 CID
AC-91223	FB	92,000	(1) EM-1, (1) EM-2	(1) CM-2, (1) CM-3	(2) 10 CID
AC-11122	FB	96,000	(2) EM-1	(2) CM-2	(2) 10 CID
DC-19922	CD	96,000	(2) EM-9	(2) CM-2	(2) 10 CID
AC-11133	FB	104,000	(2) EM-1	(2) CM-3	(2) 10 CID
DC-19933	CD	104,000	(2) EM-9	(2) CM-3	(2) 10 CID
AC-16333	FB	108,000	(1) EM-3, (1) EM-6	(2) CM-3	(2) 10 CID
DC-12175	CD	120,000	(1) EM-3	(1) CM-5	(1) 05K or 05G

LEGEND:

FB = Free Blow  
 CD = Corner Ducted

EM = Evaporator Module  
 CM = Condenser Module  
 CID = Cubic Inch Displacement

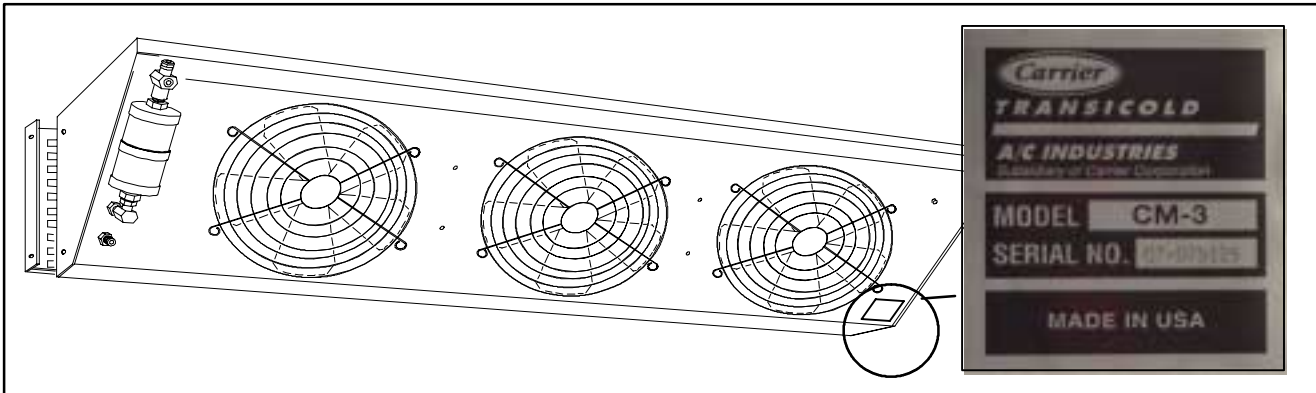

Figure 1-1 Condenser Model - Serial Number Location

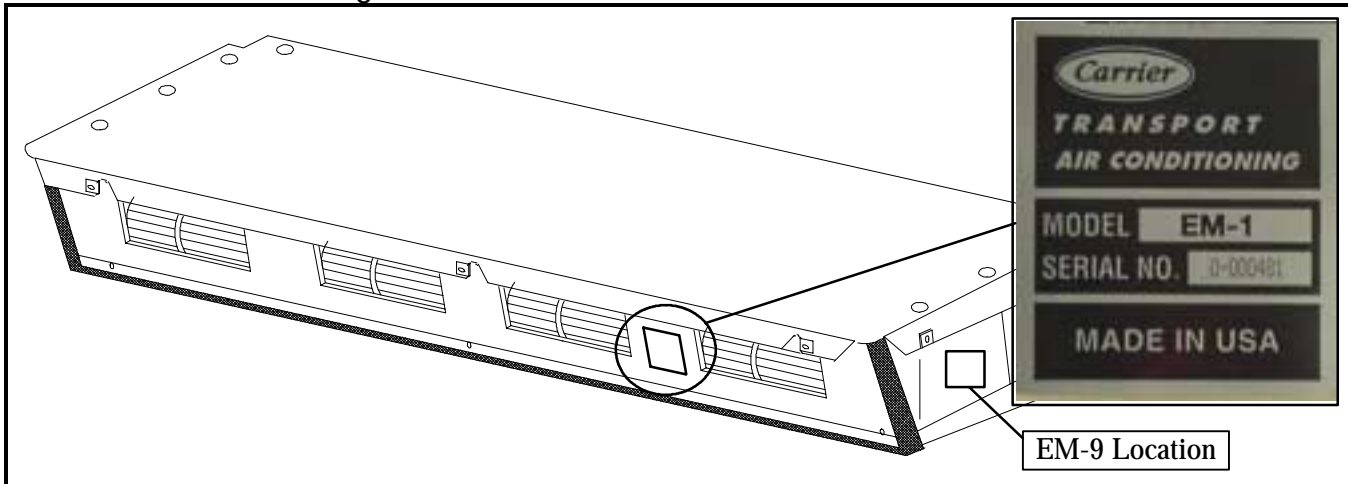

Figure 1-2 GEN 4 Evaporator Model - Serial Number Location

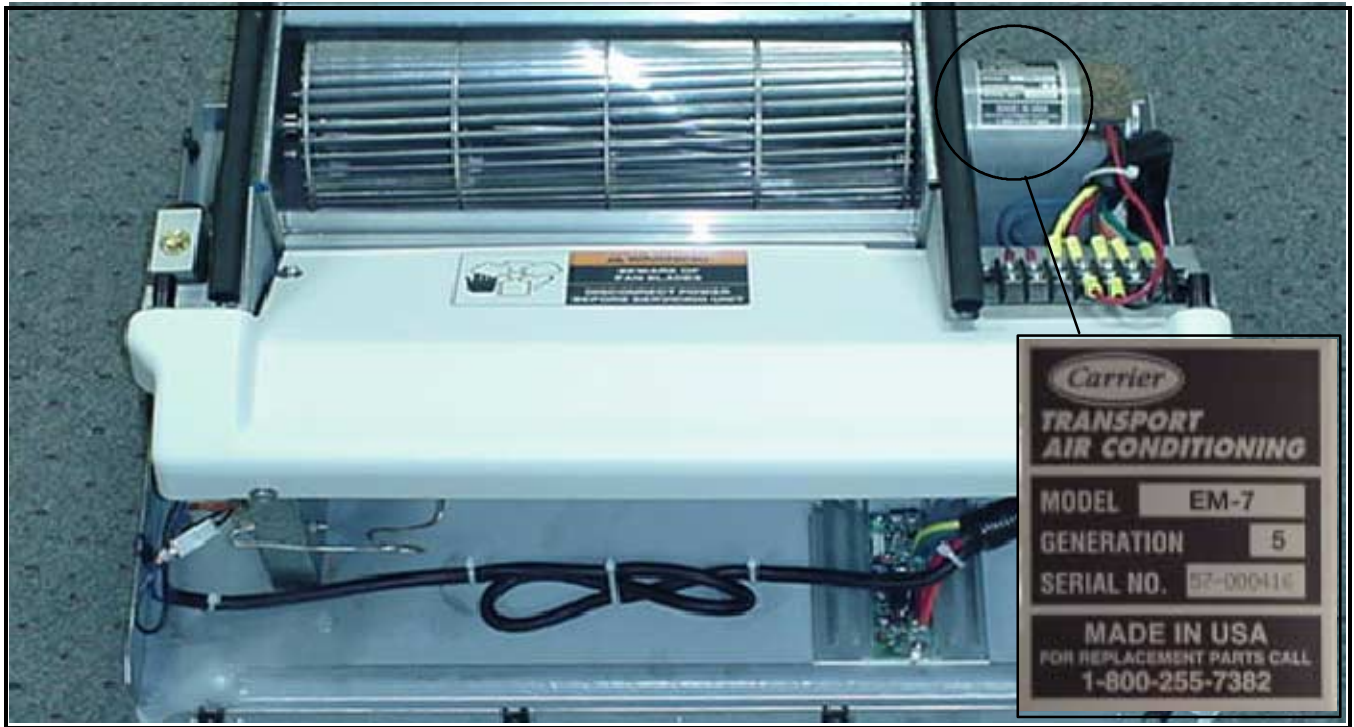

Figure 1-3 GEN 5 Evaporator Model - Serial Number Location

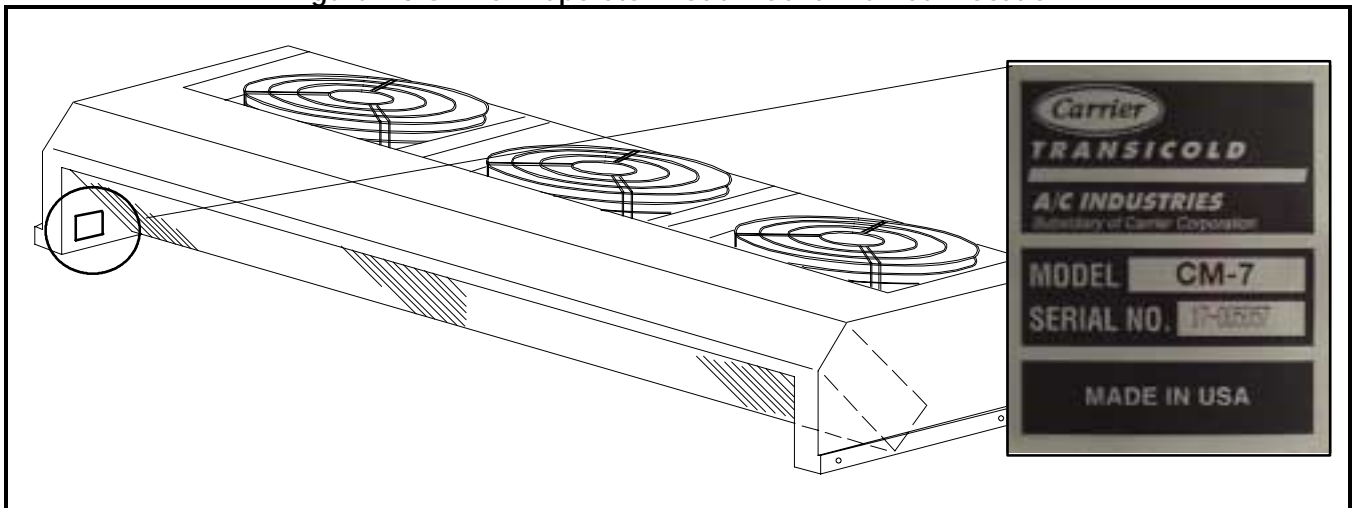

Figure 1-4 CM-7/11 Rooftop Condensers - Serial Number Location

#### 1.4 SYSTEM COMPONENTS

1. Thermostat - A thermostat is a temperature sensitive device, which when activated, signals the electro-magnetic clutch to engage.
2. Electro-Magnetic Clutch - The electro-magnetic clutch controls the operation of the compressor. When engaged, the compressor circulates refrigerant and provides cooling (See Figure 1-5).
3. Compressor - The compressor is a belt driven, high-pressure pump, which circulates the refrigerant through the evaporator and condenser (See Figure 1-5). The operation of the compressor is controlled by the electro-magnetic clutch, which in turn is controlled by the thermostat.
4. Condenser - The condenser is normally located in the skirt or on the roof of the bus (vehicle), (See Figure 1-5). Its primary function is to reject heat, which

- was transferred to the refrigerant by the evaporator from the passenger compartment of the bus (vehicle).
5. Filter/Dryer - The filter/dryer removes moisture and particulate matter from the refrigerant (See Figure 1-5).
6. Expansion Valve/Block Valve - Meters the refrigerant flow into the evaporator coil.
7. Evaporator - The evaporator is located in the interior of the bus (vehicle) (See Figure 1-5). Its primary function is to transfer heat contained in the passenger compartment air, into the refrigerant, which is circulated by the compressor, through the evaporator coil. During this process the air is also filtered and dehumidified
8. Refrigerant - A refrigerant is any material that possesses high heat transfer capabilities. Its primary function is to act as the medium for heat transfer, which facilitates the movement of heat from the passenger compartment to the outside air. Refrigerant under varying pressures exists in different states, and

performs different heat transfer functions. Under low pressure, refrigerant exists as a gas that can absorb heat. Under high pressure, refrigerant exists as a liquid that can reject heat. The heat transfer properties

exhibited when refrigerant changes state is the foundation of the refrigerant cycle.

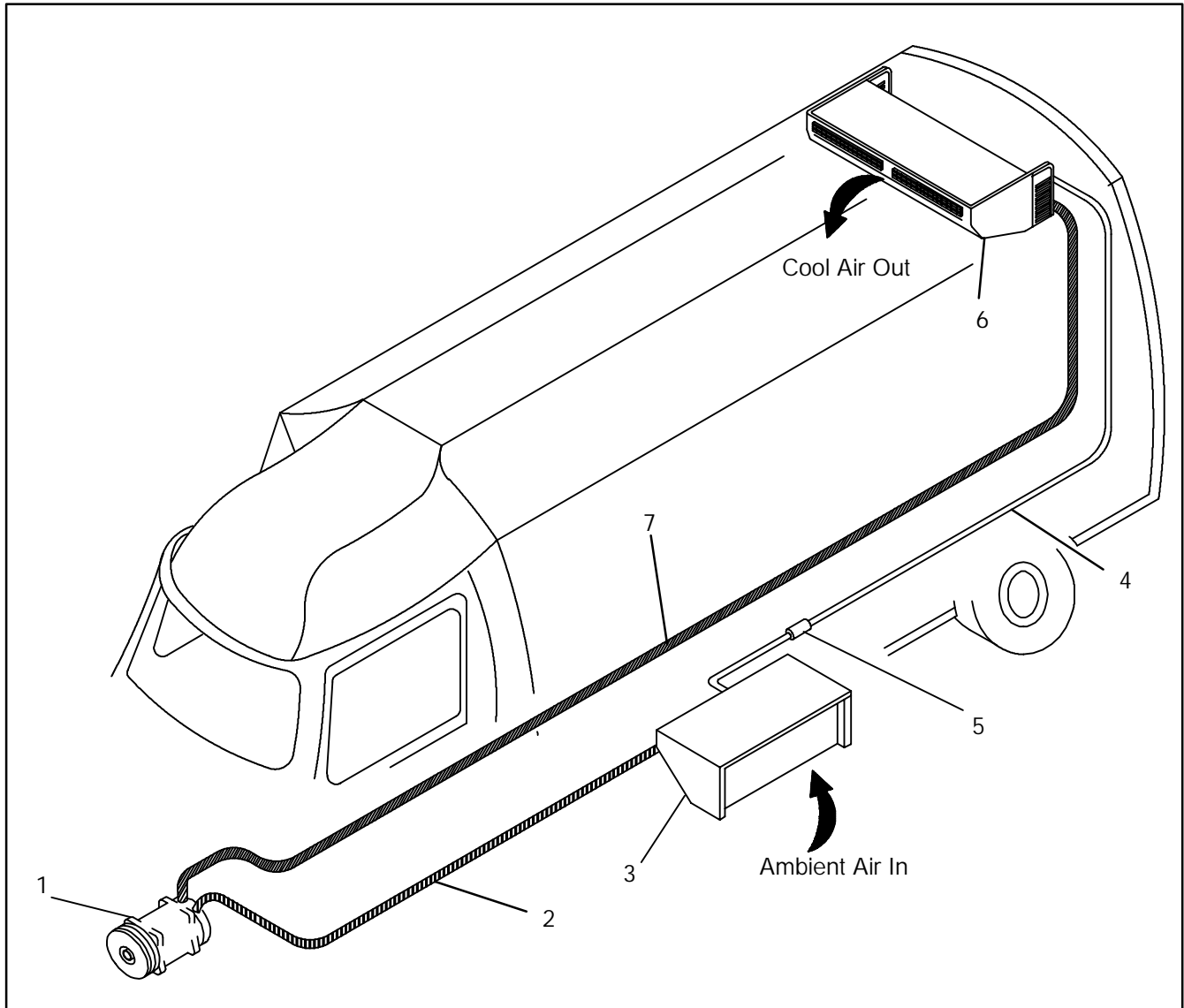

- |                             |                 |
|-----------------------------|-----------------|
| 1. Compressor               | 5. Filter Drier |
| 2. Discharge Line (hot gas) | 6. Evaporator   |
| 3. Condenser                | 7. Suction Line |
| 4. Liquid Line              |                 |

**Figure 1-5 Refrigerant Flow and Typical Component Locations**

**1.5 COOLING CYCLE**

The unit operates as a vapor compression system using R-134a as the refrigerant (See Figure 1-6). The compressor raises the pressure and the temperature of the refrigerant and forces it thru the discharge lines into the condenser tubes. The condenser fan circulates surrounding air (which is at a temperature lower than the refrigerant) over the outside of the condenser tubes. Heat transfer is established from the refrigerant (inside the tubes) to the condenser air (flowing over the tubes). The condenser tubes have fins designed to improve the transfer of heat from the refrigerant gas to the air; this removal of heat causes the refrigerant to liquify. Liquid refrigerant leaves the condenser and flows to the filter

drier. The filter drier contains a medium (absorbent) that keeps the refrigerant clean and dry.

From the filter-drier, the liquid refrigerant then flows to the block type expansion valve. The expansion valve reduces pressure and temperature of the liquid and meters the flow of liquid refrigerant to the evaporator to obtain maximum use of the evaporator heat transfer surface.

The low pressure, low temperature liquid that flows into the evaporator tubes is colder than the air that is circulated over the evaporator tubes by the evaporator fans. Heat transfer is established from the evaporator air (flowing over the tubes) to the refrigerant (flowing inside the tubes). The evaporator tubes have fins to increase heat transfer from the air to the refrigerant;

therefore the cooler air is circulated to the interior of the vehicle.

The transfer of heat from the air to the low temperature liquid refrigerant in the evaporator causes the liquid to

vaporize. This low temperature, low pressure vapor refrigerant then continues through the suction line and returns to the compressor where the cycle repeats.

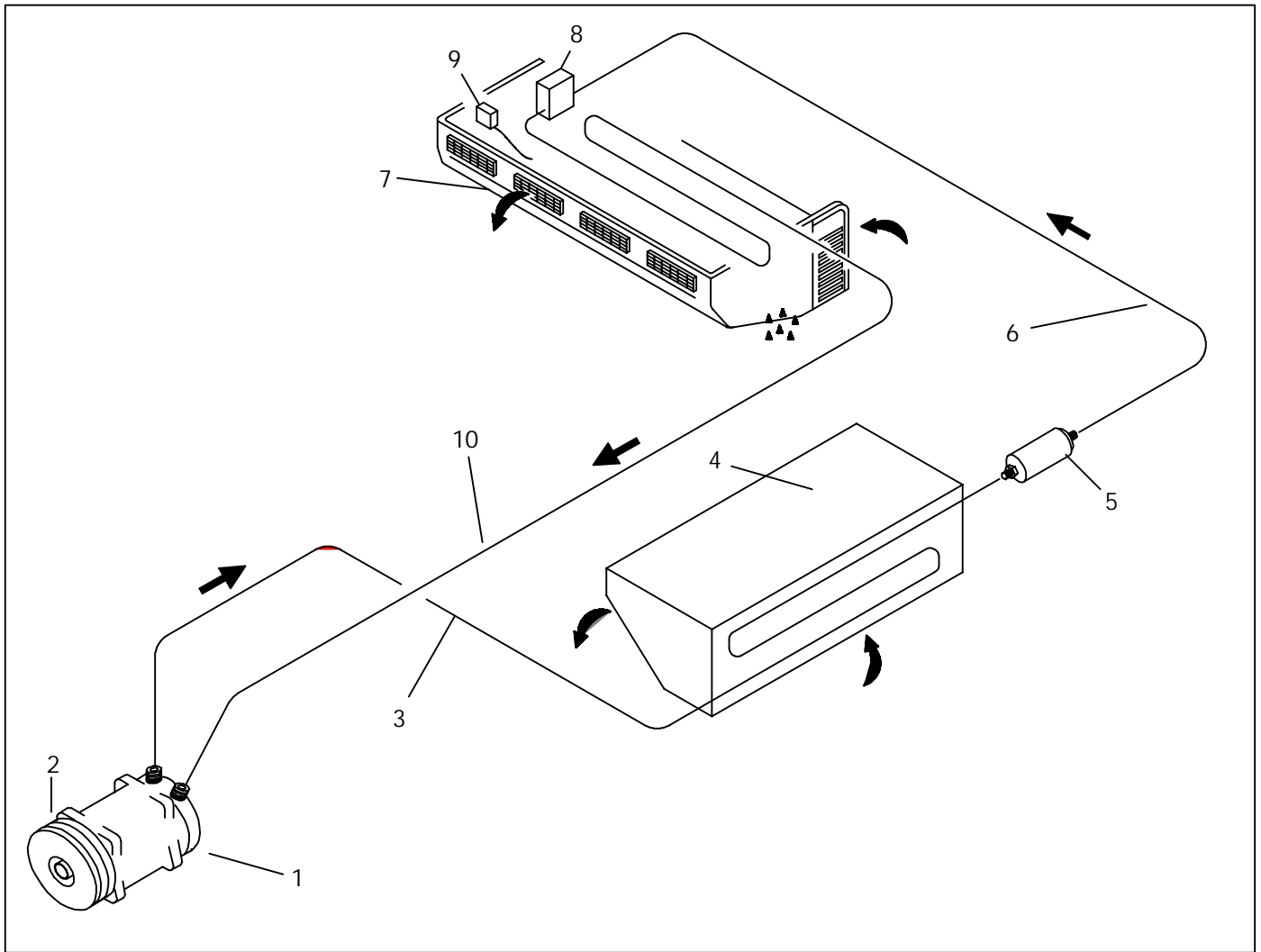

- |                            |                           |
|----------------------------|---------------------------|
| 1. Compressor              | 6. Liquid Line            |
| 2. Electro-Magnetic Clutch | 7. Evaporator             |
| 3. Discharge Line          | 8. Block Valve            |
| 4. Condenser               | 9. Thermostat-(Freeze-Up) |
| 5. Filter Dryer            | 10. Suction Line          |

Figure 1-6 Refrigerant Flow Diagram



## 1.6 EVAPORATORS

Evaporators are located in the interior of the vehicle. Their primary function is to transfer heat contained in the passenger compartment into the refrigerant. The evaporators may be free blow mounted in the front, side or rear of the vehicle (bus) to blow directly into the

interior or ducted to distribute the air in a planned pattern, (the EM-20 is designed to sit on the vehicle's floor).

Refer to Table 1-3 (Gen 4) and Table 1-4 (Gen 5) for Carrier Transport Air Conditioning evaporator assemblies, their approximate CFM, Amp draw, weight, and cooling/heating BTU's.

**Table 1-3 GEN 4 EVAPORATORS**

Component	Type	CFM (Approx)	Amps (High Speed)	Weight	BTU Cooling (Approx)	BTU Heating (Optional)
EM-1 GEN 4	FB - F/R/SM	1330	18@12.5V	65 Lbs.	52,000	60,000
EM-2 GEN 4	FB - F/R/SM	750	19@12.5V 10@25V	55 Lbs.	39,000	40,000
EM-3 GEN 4	FB - RM	2000	53@12.5V 26@25V	96 Lbs.	86,000	70,000
EM-6 GEN 4	FB - F/R/SM	525	19.5@12.5V 10@25V	56 Lbs.	30,000	30,000
EM-9	DT - SM	1330	18@12.5V	85 Lbs.	52,000	60,000
EM-10	DT - RM	2060	57@25V	150 Lbs	86,000	90,000
EM-14	FB or SM	525	23@12.5V 12@25V	35 Lbs.	26,000	35,000
EM-17	RM - DT	2060	57@25V	196 Lbs.	125,000	90,000
EM-20	FL - MT - DT	425	12@12.5V 12@25V	30 Lbs.	27,000	35,000
EM-21	AMB - FB - DT	425	12@12.5V	32 Lbs.	27,000	35,000
EM-22	FB - VERTICAL	525	20@12.5V 12@25V	40 Lbs.	25,000	30,000
IW-1	FB - RW	585	28@12.5V	50 Lbs.	43,000	Not Available
IW-2	FB - FW	450	21@12.5V	20 Lbs.	28,000	Not Available
IW-7	FB - FW	500	15@12.5V	14 Lbs.	20,000	Not Available
IW-14	FB - RW	405	21@12.5V	35 Lbs.	30,000	Not Available

**Table 1-4 GEN 5 EVAPORATORS**

Component	Type	CFM (Approx)	Amps (High Speed)	Weight	BTU Cooling (Approx)	BTU Heating (Optional)
EM-1	FB - F/R/SM	1500	30@12.5V 16@25V	60 Lbs.	53,000	Not Available
EM-2	FB - F/R/SM	1200	23@12.5V 12@25V	49 Lbs.	43,000	Not Available
EM-3	FB - RM	2200	46@12.5V 24@25V	90 Lbs.	90,000	Not Available
EM-7	FB - F/R/SM	800	15@12.5V 10@25V	41 Lbs.	35,000	Not Available

### LEGEND:

AMB Ambulance Unit  
 DT Ducted Unit  
 FM Front Mount  
 FW Front Wall Mounted  
 IW In-Wall Unit

EM Evaporator Module FB - Free Blow Unit  
 FL Floor Mounted  
 RW Rear Wall Mounted  
 RM Rear Mount

## 1.7 CONDENSERS

Condensers are normally located on the outside of the vehicle. Their primary function is to reject heat absorbed by the refrigerant from the passenger compartment to the outside air. Condensers are normally located on the

vehicle skirt or on the roof. If space in the vehicle skirt is a problem, two (2) CM-2's or two (2) CM-3's can be stacked on each other with a kit available from Carrier Transport Air Conditioning. Carrier Transport Air Conditioning condensers are listed in Table 1-5.

**Table 1-5 CONDENSERS (Used With GEN 4 And GEN 5 Series)**

Component	Type	CFM (Approx)	Amps	Weight	BTU Heat Rejection
CM-2	SKT MT	1600	14@12.5 16@25V	66 Lbs.	57,000
CM-3	SKT MT	2400	21@12.5V 24@25V	76 Lbs.	76,000
CM-4	SKT OR RF MT	1300	13@12.5V	59 Lbs.	43,000
CM-5	SKT MT	6000	41@24V	202 Lbs.	162,000
CM-7	RF MT	1950	21@12.5V 12@25V	87 Lbs.	76,000
CM-11	RF MT	1300	13@12.5V	77 Lbs.	57,000
KR-4	RF MT	3500	44@12.5V 22@25V	187 Lbs.	130,000
CM-14	SKT MT	1800	27.5@12.5V 30@25V	92 Lbs.	85,000
CM-2 STKD (2 ea)	SKT MT	3200	30@12.5V	144 Lbs.	114,000
CM-3 STKD (2 ea)	SKT MT	4800	45@12.5V	168 Lbs.	152,000

### LEGEND:

CM - Condenser Module  
 KR - 4 Fan Roof Mounted  
 SKT - Skirt Mounted  
 RF - Roof Mounted  
 STKD - Stacked Condenser Assembly

## 1.8 PRE-INSTALLATION INSPECTION

Immediately upon receipt of your Carrier Transport Air Conditioning system:

Check the number/amount of cartons and skids/pallets against the shipping company's "Bill of Lading" (B.O.L.). Inspect all shipping cartons for any evidence of damage in transit. If visible damage exists, indicate on "Bill of lading" and initiate a claim directly with the transporting company. All instances of visible damage or missing cartons are the responsibility of the transporting company.

Unpack and check components for hidden damage. If hidden damage exists, initiate a claim directly with the transporting company. All instances of hidden damage are also the responsibility of the transporting company.

Check contents of cartons against the enclosed packing lists. If any parts are missing, incomplete, or defective, call Carrier Transport Air Conditioning customer service for assistance.

Before installing any evaporator assembly, spin the blower wheels by hand to insure they turn freely. It is possible they could have been knocked out of alignment during transit. This would be easy to correct before installing.

### Note

Before attempting to install any evaporator or condenser always insure that each component will fit in the location of choice.

## SECTION 2

### EVAPORATORS

#### 2.1 INTRODUCTION

##### 2.1.1 Description

Evaporators are located in the interior of the bus. Their primary function is to transfer heat contained in the passenger compartment into the refrigerant. The evaporators may be free blow mounted in the front, side or rear of the bus to blow directly into the interior or ducted to distribute the air in a planned pattern.

##### 2.1.2 Location

Before attempting to install any evaporator, always insure that the evaporator will fit in the location of choice.

##### 2.1.3 Cap Plugs

Carrier Transport Air Conditioning evaporators are leak-checked at the factory then shipped with a small charge of inert gas which keeps the coil free from moisture. The evaporator caps/plugs must not be removed until ready to use.

##### 2.1.4 Blower Wheels

Before installing any evaporator assembly, spin the blower wheels by hand to insure they turn freely. It is possible they could have been knocked out of alignment during transit. This would be easier to correct before installing.

##### 2.1.5 Aesthetics

When the installation is completed, the evaporator fittings and trim should be visually examined for completeness and looks. All trim should be flush and mounting hardware hidden from sight where possible in a manner designed to be pleasing to the customer.

##### 2.1.6 Mounting (Front & Rear)

Carrier Transport Air Conditioning recommends sufficient structure be built into the bus ceiling by the "OEM" (original equipment manufacturer) so that the bus roof will not have to be drilled through when mounting the evaporator assemblies. When and if the bus roof is drilled through to mount the evaporator, care

must be taken to ensure that the bus roof is properly sealed to prevent leaks.

##### 2.1.7 Mounting (Side)

Mounting brackets (front & rear) must always be attached to the bus roof bows. Mounting brackets to the bus ceiling skin will not provide sufficient support for the evaporator.

##### 2.1.8 Drain Lines

The drain lines must always run down hill immediately from the attachment point on the evaporator drain pans. Both drains should be run independently and in opposite directions for maximum efficiency. Drain line routing must be smooth and without kinks. Failure to properly route the drain lines may result in water back-up into the passenger compartment.

##### 2.1.9 Ducted Systems

In ducted systems, insure that all refrigerant hoses and electrical harnesses are firmly attached to the ceiling. Failure to secure these components may cause noise and vibration, inadequate air flow, or a blockage that will degrade the system cooling.

##### 2.1.10 Bus Headliners

Bus ceilings with noise abatement headliners (perforated) must be sealed with a non-porous material in the areas that will be covered by ducts prior to installation of the ducts to the ceiling. Failure to seal these areas will cause dissipation of the air and marginal cooling.

##### 2.1.11 Mounting Hardware

All Carrier Transport Air Conditioning evaporators are supplied with the proper mounting hardware. Never substitute mounting hardware without the permission of Carrier Transport Air Conditioning. Proper mounting procedures are supplied with every evaporator. Use of substitute hardware or failure to follow the installation instructions may result in structural fatigue and/or breakage.

## 2.2 REAR MOUNTED EVAPORATORS

### 2.2.1 GEN 4/5 Series EM-1, EM-2, EM-3, EM-7, EM-6, & EM-14

To install the evaporator assembly in the rear of a bus utilize the following installation procedures:

1. Un-pack the evaporator and check for any obvious damage (Refer to Sec. 1.8).
2. Check the interior of the bus/vehicle to make sure the evaporator(s) can be safely and properly installed in the selected area. Refer to Table 2-1 or Table 2-2 for evaporator dimensions.

**Table 2-1 GEN 4 EVAPORATORS**

Evaporator	A (width)	B (height)	C (depth)
EM-1	41.12inch	9.88 inch	22.25 inch
EM-2	41.12 inch	9.88 inch	22.25 inch
EM-3	59.44 inch	10.75 inch	22.75 inch
EM-6	25.63 inch	9.88 inch	22.25 inch
EM-14	36.13 inch	7.00 inch	19.91 inch

**Table 2-2 GEN 5 EVAPORATORS**

Evaporator	A (width)	B (height)	C (depth)
EM-1	41.25inch	7.62 inch	19.13 inch
EM-2	33.95 inch	7.62 inch	19.13 inch
EM-3	59.44 inch	7.62 inch	19.13 inch
EM-7	26.64 inch	7.62 inch	19.13 inch

#### NOTE

Except for the EM-3, all the evaporators listed in paragraph 2.2.1 can also be mounted in the front and/or on either side of the vehicle.

#### NOTE

In some cases it may be necessary to relocate the ceiling lights and/or speakers.

3. Plan refrigerant hose, drain lines, and electrical harness routing. Some small bus applications will allow routing inside the walls and back panel. If this is the case it is better to route your hose, drain lines, and electrical harnesses before mounting the evaporator. Refer to Section 4 for detailed instructions regarding hose, harness, and drain-line routing.
4. Locate and review installation instructions supplied with the evaporator assembly. Review piping and wiring diagrams for proper hose and fitting size, plus the proper wiring harness. Refer to Section 4 for detailed instructions regarding hose and harness routing.
5. For ease of installation, trace evaporator tray unto cardboard or other thin material. Refer to the installation drawing for the dimension the evaporator assembly has to be from the back wall. Refer to Table 2-3 or Table 2-4 for these dimensions if the installation drawing is not available. Example: For an EM-1 Gen 4, this dimension is 7 Inches. Without this added dimension the return air grill will not fit on to the evaporator cover.

#### NOTE

An optional rear panel is available for all the Gen 5 evaporator assemblies. This panel is used when the rear wall is curved and the evaporator cover cannot fit flat against the rear wall. This panel can be trimmed to compensate for the ceiling curve.

6. Mark and drill all mounting holes and cut out template. See Figure 2-1.
7. Mark center of template in order to match center of bus ceiling. See Figure 2-1.

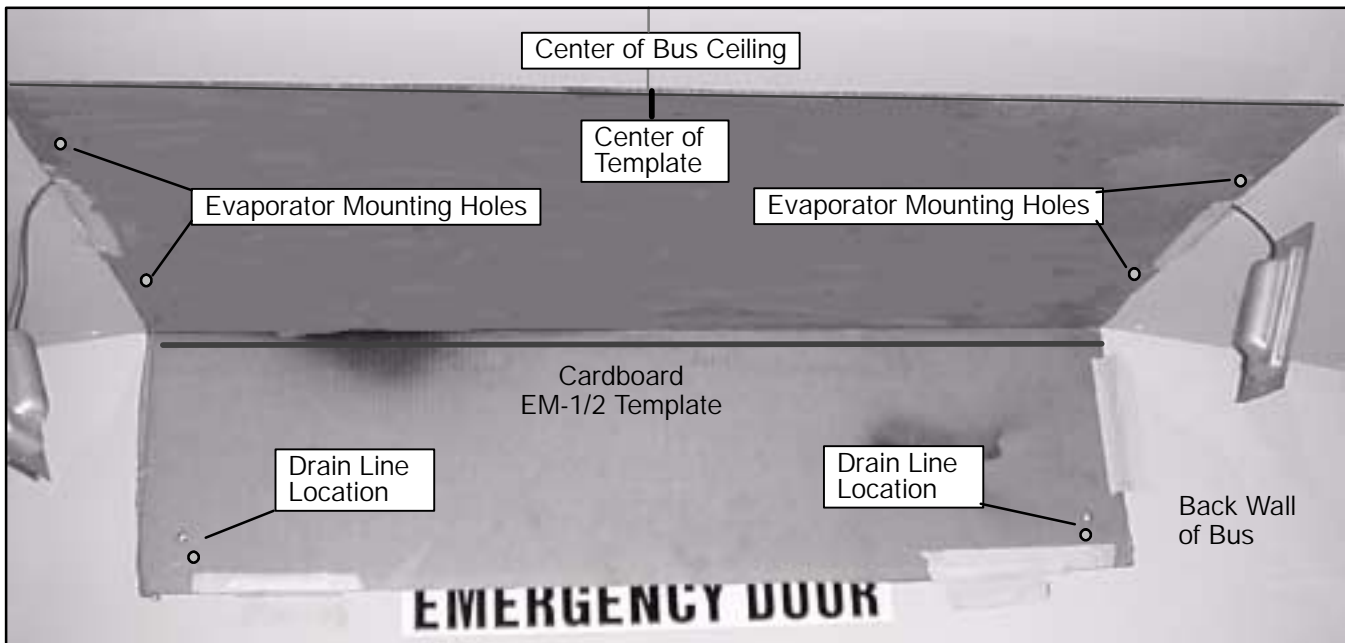

**Figure 2-1 Template For EM-1 And EM-2 (GEN 4)**

**Table 2-3 DISTANCE TO BACK WALL (GEN 4)**

Gen 4 Evaporator	Distance to back wall
EM-1	7 Inches
EM-2	7 Inches
EM-3	4.5 Inches
EM-6	7 Inches
EM-14	8.75 Inches

**Table 2-4 DISTANCE TO BACK WALL (GEN 5)**

Gen 5 Evaporator	Distance to back wall
EM-1	4.125 Inches
EM-2	4.125 Inches
EM-3	4.125 Inches
EM-7	4.125 Inches

**Figure 2-2 Measurement To Wall (GEN 4)**

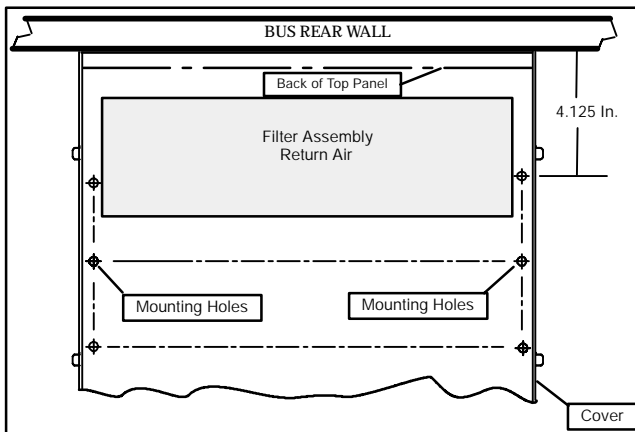

**Figure 2-3 Measurement To Wall (GEN 5)**

8. Locate center of bus ceiling and mark.
9. Centering the template against back wall and ceiling, mark the bus ceiling and wall for evaporator mounting holes and drain lines.
10. Using a 3/16 drill bit, drill 4 holes through the bus ceiling. The smaller bit will allow you to check the angle of the hole and where you have exited the bus roof. If the angle is incorrect, the 3/16th hole is easily repaired with a pop-rivet.
11. After determining the pilot hole is correct enlarge the 4 holes to 7/16 inch. See Figure 2-4.



**Figure 2-4 7/16 Inch Holes in Bus Roof**

12. Matching holes in reinforcing rails to holes in bus roof, drop 3/8 inch carriage bolts through mounting rails and the roof. The carriage bolts should drop through the roof easily. You may have to open the holes slightly, Do not force the bolts through the roof or ceiling.



**Figure 2-5 Carriage Bolts & Sealant**

13. Pull reinforcing rails and carriage bolts away from bus roof. Apply a bead of sealant down the center of each rail and under the carriage bolt heads. See Figure 2-6 and Figure 2-7.

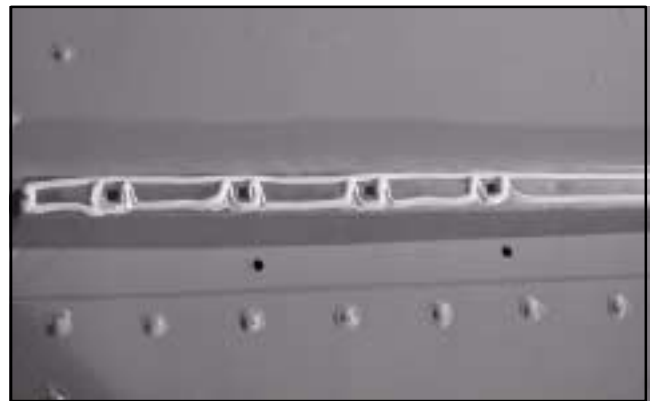

**Figure 2-6 Sealant Pattern on Mounting Channel**



**Figure 2-7 Carriage Bolt Sealing**



**Figure 2-8 Locking Pliers Clamped to Carriage Bolts**

**Installation Hint**

In order to keep carriage bolts from being forced out of the reinforcing rails on the bus roof, use small locking pliers to hold the bolts in place (See Figure 2-8). Tighten the bolts until the evaporator is almost touching the locking pliers (See Figure 2-9). Remove the locking pliers and continue tightening as described in step 14

**Installation Hint**

For ease in installing the evaporator cover on buses with heavily contoured ceilings, insert spacers (wood or metal) between the evaporator panel and bus ceiling. See Figure 2-17, item j Without these spacers you may need to trim the top side edges of the evaporator cover.

14. Mount evaporator using 3/8 inch hardware and tighten to bus ceiling. Do not over tighten, as this will distort either the bus ceiling and/or roof.



**Figure 2-9 Locking Pliers & Evaporator**



**Figure 2-10 Evaporator Mounted to Flat Ceiling**

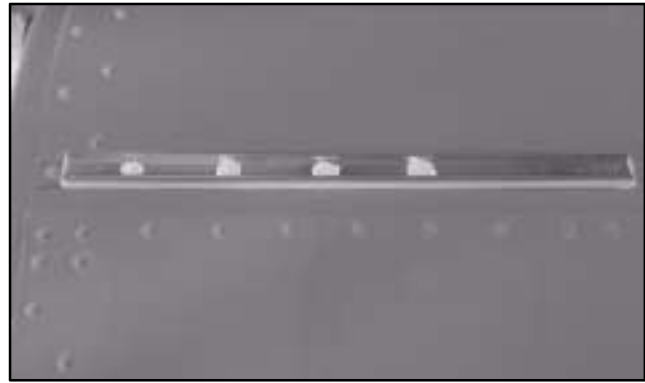
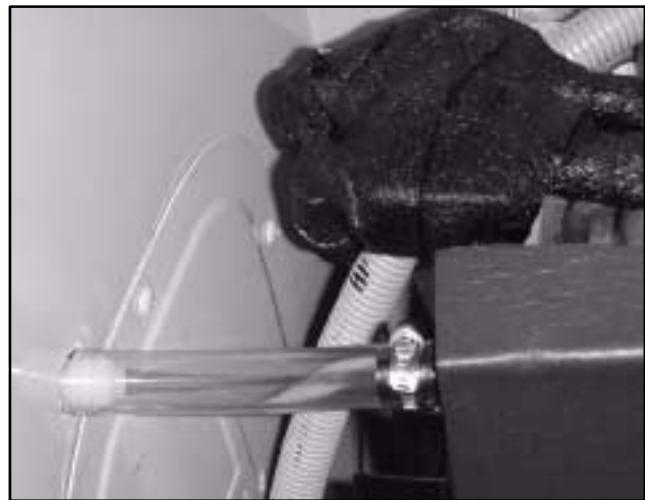

**Figure 2-11 Mounting Channel Sealing**

15. Seal outer edge of reinforcing rails. Improper sealing of the reinforcing rails will allow water to leak into the passenger compartment (See Figure 2-11).

16. If refrigerant hose and wiring harness were previously routed through the bus wall they can be connected at this time. If not, the hose and harness, plus the drain lines must be surface routed on the bus wall using the hose cover kit provided. Refer to Section 4 for detailed instructions regarding hose and harness routing.

17. After the liquid and suction lines have been connected and you are sure there are no leaks, the suction fitting and the block valve must be wrapped with "no-drip" tape in order to keep them from dripping condensate into the passenger compartment.



**Figure 2-12 Block Valve Insulation**

18. Connect two drain lines to the EM-1 evaporator drain pan assembly. Secure both drain lines with the clamps provided with the system. One drain line can be routed with the refrigerant hose and wiring harness, while the other must be routed to the opposite side of the bus. Drain lines must always run downhill, and care must be taken not to kink the drain lines. Plastic 90° elbows may be required to keep drain lines from kinking. If in doubt, use the elbows supplied.

19. After the drain lines have been routed to the outside of the bus they should be cut approximately 6 inches below the floor. Install condensate valve over the ends of the drain lines. This prevents air from being drawn through the lines into the evaporator which will stop the flow of condensate from the drain pan. It also prevents insects from entering the drain lines.

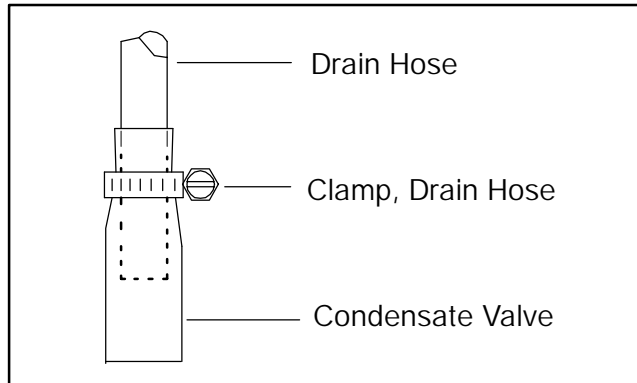

**Figure 2-13 Drain line & Condensate Valve**

20. Fit evaporator cover over unit. If evaporator cover needs no trimming mount cover with the hardware provided.



**Figure 2-14 Installed Evaporator**

21. With the cover removed, note the distance between the top of the unit and the contour of the bus ceiling. If this distance is more than 1 inch, it must be closed off to prevent any recirculation over top of the evaporator. Use the evaporator trim strip provided. Flat or almost flat ceilings do not require any trim strip.

22. Install return air grill to the evaporator cover. Some trimming could be involved.



**Figure 2-15 Return Air Grill**

23. Clean evaporator and hose covers with a mild cleaning solution. Clean all debris from the interior of the bus.

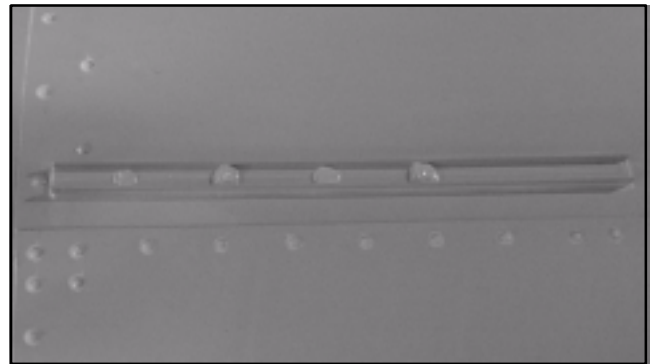

**Figure 2-16 Painted Mounting Channel**

24. For aesthetic purposes only, it is recommended that the exterior reinforcing rails be painted the same color as the bus exterior.

A typical installation drawing for a GEN-4 front or rear mounted evaporator is shown in Figure 2-17 and a completely installed rear mounted evaporator is shown in Figure 2-18.

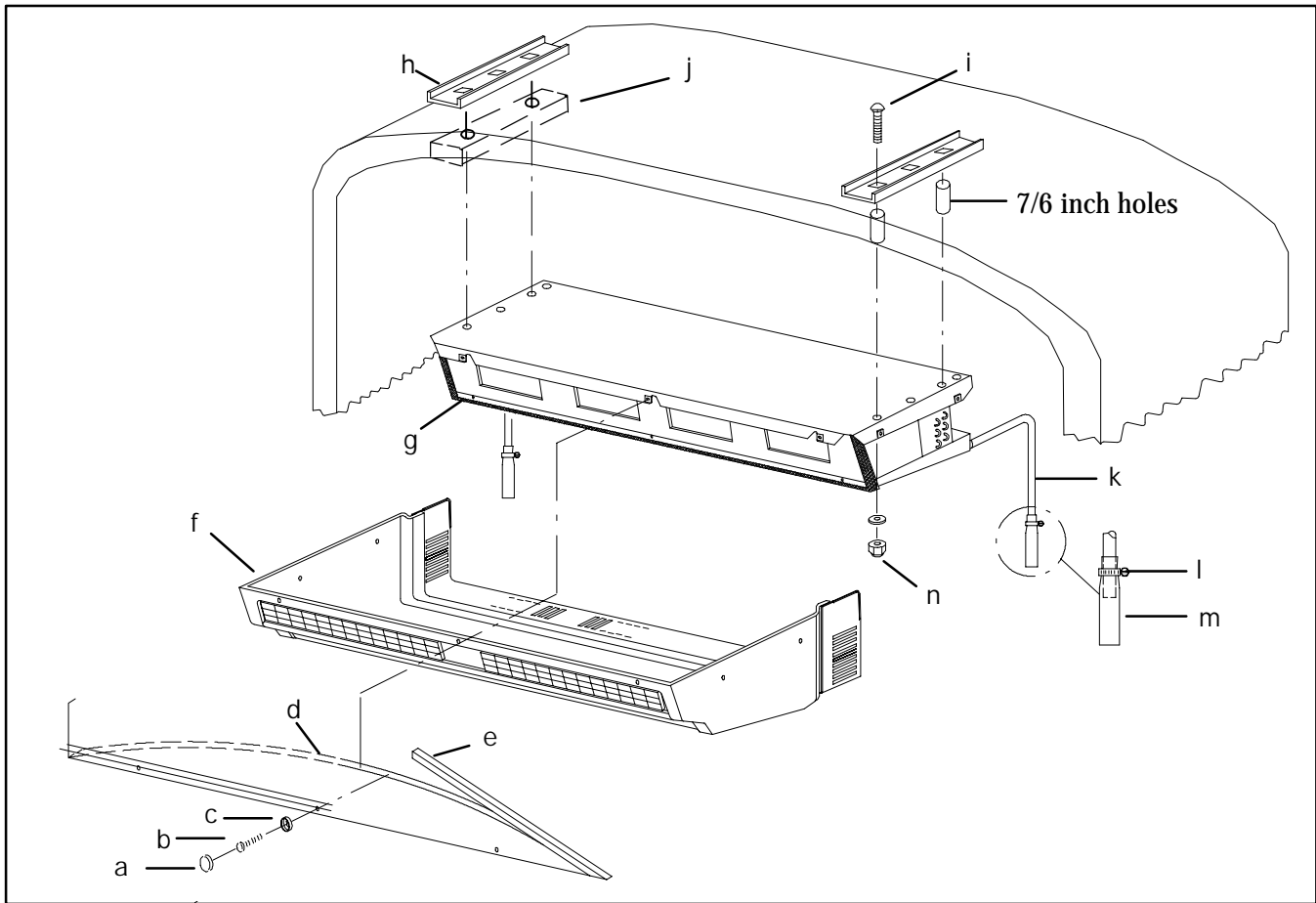

- |    |                  |    |                               |
|----|------------------|----|-------------------------------|
| a. | Snap Cap         | h. | Mounting Channel              |
| b. | Pan Head Screw   | i. | Carriage Head Bolt 3/8-16 x 4 |
| c. | Snap Cap washer  | j. | Optional Spacers              |
| d. | Trim Strip       | k. | Drain Line                    |
| e. | Flexible Trim    | l. | Drain Line Clamp              |
| f. | Evaporator Cover | m. | Condensate Valve (Kazoo)      |
| g. | Evaporator       | n. | Locking Nut 3/8-16            |

Figure 2-17 GEN-4/5 Front/Rear (EM-1, 2, 6, & 14) Evaporator & Installation Hardware



Figure 2-18 Rear Mount Evaporator - Installed





Figure 2-19 EM-6 Rear Mounted In An Extended Roof Van

## 2.2.2 EM-3 EVAPORATOR GEN 4 OR GEN 5

To install the EM-3 utilize the installation procedures outlined in Paragraph 2.2 except as noted below. See Figure 2-20 for a typical EM-3 installation drawing.

### NOTE

Threaded rod (3/8-16) is supplied with the EM-3 instead of 4 inch carriage bolts. Depending on the contour of the bus roof the distance from the ceiling to the evaporator could be up to 10 inches (Installer purchased 3/8-16 carriage bolts can be substituted for the threaded rod).

### NOTE

Most EM-3 installations will require the addition of spacers between the ceiling roof and the evaporator assembly (See Detail A, Figure 2-20). These spacers will help keep the

bus roof and/or evaporator from distorting when tightening the lock nuts.

### WARNING

**Do not attempt to modify the EM-3 evaporator top panel. Modifications to the top panel could structurally weaken the evaporator assembly, causing system failures and/or injuries to passengers.**

### NOTE

Any refrigerant hose and/or electrical harness that was routed behind the evaporator assembly must be secured to the back wall or ceiling with insulated clamps.

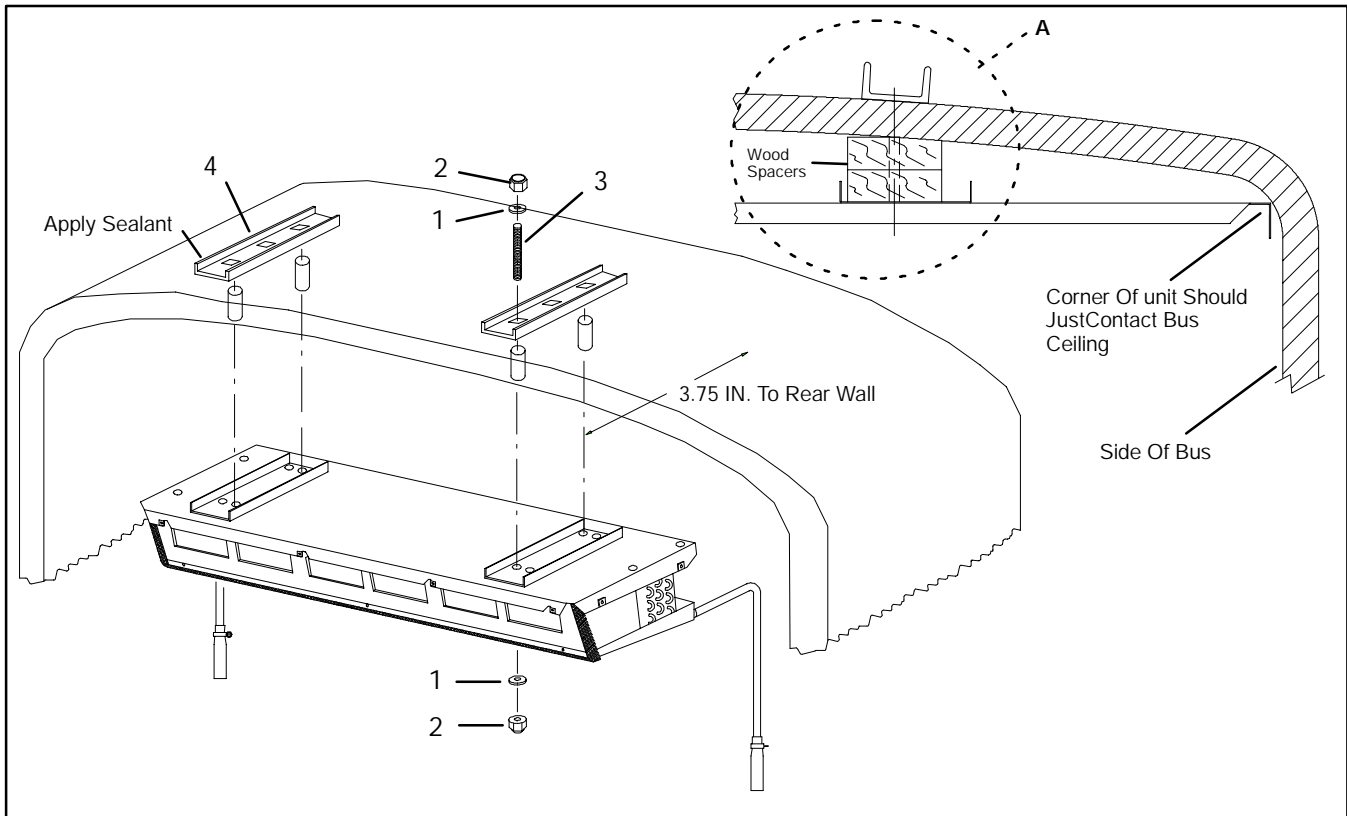

- |                            |  |
|----------------------------|--|
| 1. 3/8 Flat Washer         | 3. 3/8-16 Threaded Rod (Cut To Length) |
| 2. 3/8-16 Hex Nut, Locking | 4. Mounting Bar                        |

**Figure 2-20 EM-3 Installation Diagram**

### 2.3 SIDE MOUNTED EVAPORATOR - EM-1, EM-2, EM-6, EM-7, & EM-14

To install a side mounted evaporator assembly utilize the following installation procedures:

- a. Un-pack the evaporator and check for any obvious damage (Refer to Sec 1.8).
- b. Check the interior of the bus/vehicle to make sure the evaporator(s) can be safely and properly installed in the selected area.
- c. Plan refrigerant hose, drain lines, and electrical harness routing.
- d. Locate and review installation instructions (See Figure 2-23). Review system piping and wiring diagrams for proper hose and fitting size, plus the proper wiring harness. Refer to Section 4 for detailed instructions regarding hose and harness routing.
- e. Locate full-scale drawing of the side mounted evaporator you are installing. Glue drawing onto cardboard or other thin material. Cut-out template.
- f. Hold template to bus ceiling and back wall. See Figure 2-21.

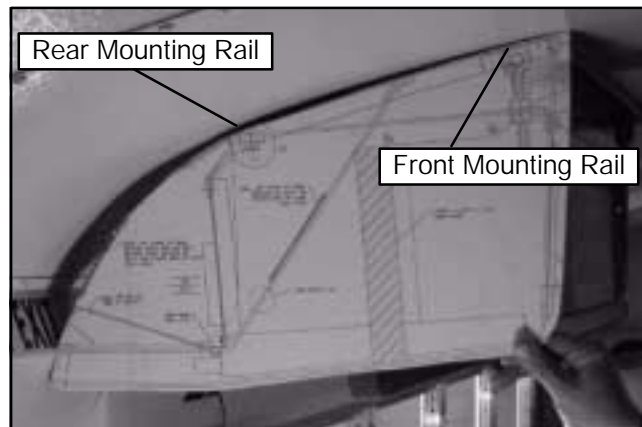

Figure 2-21 Side-Mount Template

#### CAUTION

**When selecting a location for installing the evaporator it is highly recommended that two roof bows are used to secure the mounting rails.**

- g. Mark location of front and rear mounting brackets.
- h. Insert carriage bolts into the rear mounting bracket before installing.
- i. Install the mounting brackets using steel rivets supplied in the installation kit. Insure all predrilled holes in mounting rails are utilized.
- j. Loosely assemble mounting hardware onto front hanger brackets as shown in installation drawing and Figure 2-23.

- k. Loosely install evaporator assembly onto the front and rear mounting brackets.
- l. Tighten rear mounting hardware.
- m. Level evaporator assembly front to rear using a small level and the 3/8-16 jam-nuts (See Figure 2-22).
- n. Tighten all jam-nuts and lock-nuts on front and rear mounting brackets and evaporator assembly.
- o. Connect refrigerant hoses (Liquid and Suction) and electrical harnesses at this time. Refer to Section 4 for proper routing of hoses and harnesses.
- p. After the liquid and suction lines have been connected and you are sure there are no leaks, wrap (coat) the suction fitting and the block valve with "no-drip" tape in order to keep them from dripping condensate into the passenger compartment.

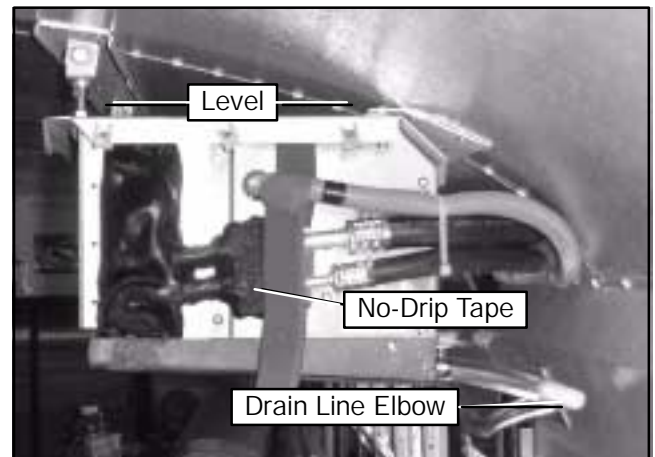

Figure 2-22 Drain Line Elbows

- q. Connect two drain lines to the evaporator assembly. Drain lines must always run downhill, and care must be taken not to kink the drain lines. Plastic 90° elbows may be required to keep drain lines from kinking. If in doubt, use the elbows supplied. See Figure 2-22.
- r. After the drain lines have been routed to the outside of the bus they should be cut approximately 6 inches below the floor. Install condensate ("kazoo") tubing over the ends of the drain lines. This prevents air from being drawn through the lines into the evaporator which will stop the flow of condensate from the drain pan. It also prevents insects from entering the drain lines.
- s. Fit evaporator cover over unit. The evaporator cover must be trimmed to fit the contour of the bus ceiling and wall.
- t. Install trim strip to the evaporator cover and side wall. Some trimming could be involved (See Figure 2-24).
- u. Mark and trim the front trim strip. Most trimming will be along the side of the trim strip.
- v. Install evaporator cover using hardware supplied.
- w. Clean evaporator and hose covers with a mild cleaning solution. Clean all debris from the interior of the bus.

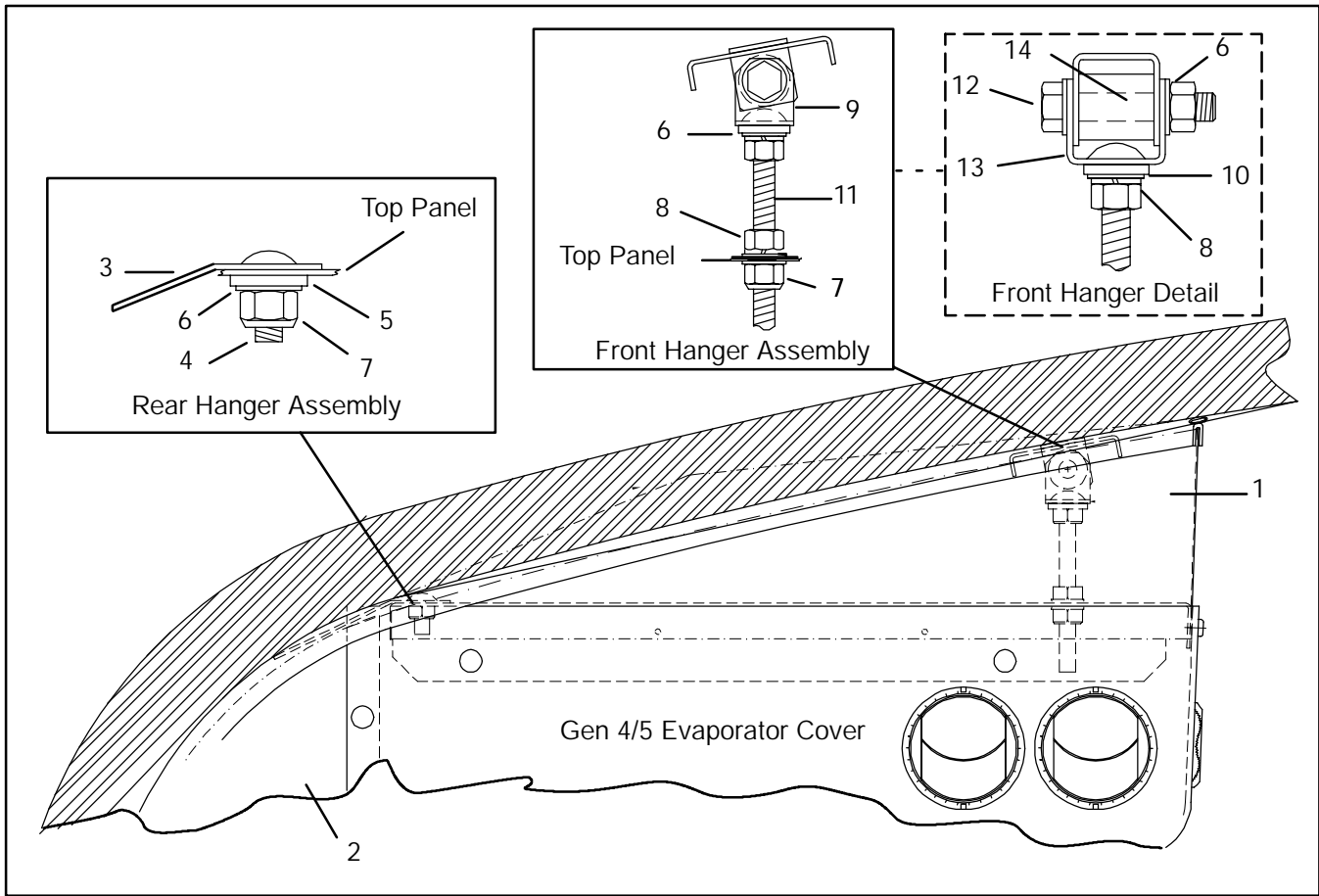

Figure 2-23 Side Mount Installation Instructions (Typical)

1. Trim Strip - Front
2. Trim Strip - Rear
3. Rear Hanger Bracket
4. 3/8-16X1 Carriage Head Bolt
5. Spacer, 1/8 Inch
6. Flat Washer
7. 3/8-16 Hex Nut, Lock
8. 3/8-16 Hex Nut
9. Front Hanger Bracket
10. Lock washer
11. 3/8-16 X 6 Carriage Head Bolt
12. 3/8-16 X 2 Hex Head Bolt
13. Front Hanger

14. Spacer, 1 inch



Figure 2-24 Side Mounted Evaporator GEN 4



Figure 2-25 EM-2 (Gen V) Side-Mount - Free Blow, Installed (Complete)

## 2.4 EM-9 DUCTED EVAPORATOR

The EM-9 evaporator is normally located slightly forward of the bus center on the drivers side and slightly rear of the bus center on the passenger side. See Figure 2-29.

To install the EM-9 ducted evaporator assembly utilize the installation procedures outlined in Section 2.3, steps a through r, then continue with the following steps:

### NOTE

Because of the ducting that will be installed the length of the bus, refrigerant hoses and electrical harnesses can enter or exit the bus floor at any convenient location. Hoses and harnesses must be bundled and clamped to the bus ceiling within the confines of the air conditioning ducts. See Figure 2-26.

### NOTE

Drain lines cannot be routed with the refrigerant hoses and electrical harnesses as shown in Figure 2-26. Drain lines must exit the evaporator and immediately run down-hill. The drain lines in Figure 2-26 are routed within the bus wiring channel to the hose cover.

- a. Trim cover to the contour of bus ceiling. Trim around the hose/harness cover if routed from rear of evaporator cover. Temporarily install over evaporator assembly.
- b. Hold duct section against the evaporator cover, ceiling, and wire channel (wall).
- c. Trace contour of duct end onto evaporator cover. Do this on both sides of the cover.
- d. Cut duct tracing leaving approximately 1/4 inch on evaporator cover. See Figure 2-26. This allows the duct section to butt against the evaporator cover.

e. Mark and cut the duct section when routing hose/harness out of the ducting. Insure the hose cover will completely cover the hole cut into the duct. See Figure 2-28 and Figure 2-33.

f. Snap a chalk line to insure duct sections are installed straight on the ceiling and the wall.

g. Starting at the evaporator, temporarily position a duct section in place.

h. Mark duct section as to where seats are located. There should be one louver per seat.

i. Using a hydraulic press or hole saw, cut 3 inch holes where the louvers are to be located, alternating top to bottom on all the duct sections. See Figure 2-27. Do not install the louvers until the installation is complete.

j. The rear duct sections should butt against the back wall of the bus. The front duct sections must be capped. Trim the end caps to fit inside the forward duct sections.

k. Cut or punch a 3 inch opening in the drivers end cap and install a louver assembly. See Figure 2-28.

l. If preferred, trim evaporator, end caps, and hose covers with trim lock.

### NOTE

Optional "school style ducting" is available from Carrier Transport AC (See Figure 2-30 & Figure 2-31). Call Carrier Transport Air Conditioning customer service for availability (1-800-673-2431).

m. Clean evaporator and hose covers with a mild cleaning solution. Clean all debris from the interior of the bus.

n. Install louvers in ducts and end cap. See Figure 2-29 for a complete ducted evaporator installation.

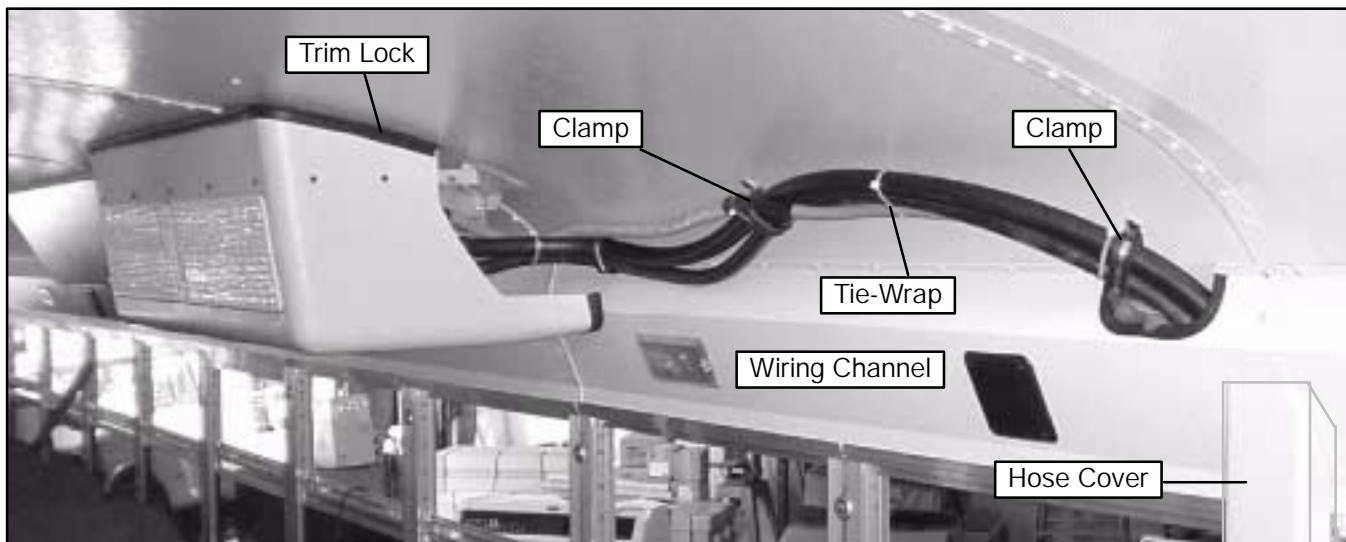

Figure 2-26 EM-9 Ducted Evaporator - Hose & Harness Routing



Figure 2-27 Punching out Louver Holes

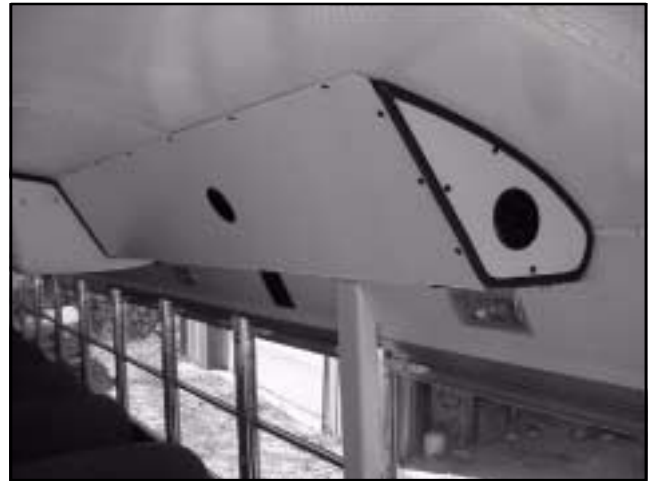

Figure 2-28 End Cap With Louver



Figure 2-29 EM-9 Ducted Evaporator - Location - Completed Assembly



Figure 2-30 School Style Ducting-Passenger Side



Figure 2-31 School Style Ducting-Drivers Side



Figure 2-32 Side Mounted Hose Routing  
(Using 45° Angles)

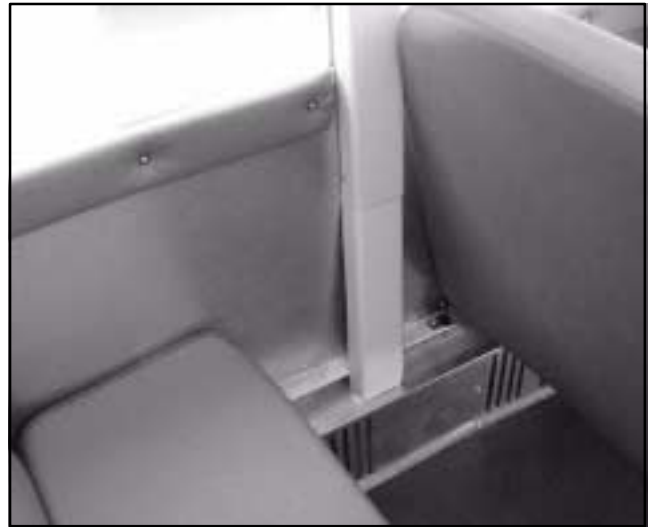

Figure 2-33 Side Mounted Hose Routing (Straight)



## 2.5 EM-17 EVAPORATOR

The EM-17 is available in single and dual loop applications. Due to the weight and size of the evaporator assembly it is recommended that this type evaporator and accompanying condenser and electrical controls be installed only by OEM's (Original Equipment Manufacturers).

Reinforced mounting channels must be welded to the

bus roof bows in order to support the evaporator assembly. Examples of this application have been given below (See Figure 2-34).

Before attempting to install this type system, it is strongly advised that you contact Carrier Transport Air Conditioning Technical Service Hot Line for assistance (1-800-450-2211).



Figure 2-34 EM-17 INSTALLED

## 2.6 IW-1, IW-2, IW-7 & IW-14 EVAPORATORS

The IW (In-Wall) evaporator assemblies are designed to be installed in the rear wall of a bus while it was being assembled at an OEM's location. There are also OEM applications where the IW has been installed in the front of a bus.

This type evaporator is not recommended for after market applications.

## 2.7 EM-20, EM-21 & EM-22 EVAPORATORS

EM-20, EM-21 and EM-22 are floor mounted heating/cooling units normally used on ambulances and/or armored trucks. For installation instructions and or information on these type systems contact Carrier Transport Air Conditioning Technical Service Hot Line (800) 450-2211.

## SECTION 3

### CONDENSERS

#### 3.1 INTRODUCTION

##### 3.1.1 Description

Condensers are normally located in the bus skirt or on the bus roof. Their primary function is to reject heat from the refrigerant to the exterior of the vehicle.

##### 3.1.2 Location

Assure that the condenser will mount properly in the location of choice. Always try to fit skirt mounted condensers between the front and back wheels and always as close to the bus skirt as possible. This assures adequate air flow and avoids recirculating heat from under the bus.

##### 3.1.3 Cap Plugs

Carrier Transport Air Conditioning condensers are leak-checked and shipped with a charge of inert gas to keep the coil dry. Do not remove any of the caps/plugs from the condensers until you are ready to hook up the refrigerant lines.

##### 3.1.4 Protection

When a skirt condenser must be mounted close to a vehicle wheel, CarrierTransport Air Conditioning recommends that the condenser be protected from wheel-sling, (mud, water road salts,etc.) by a splash guard. Failure to properly locate and protect the condenser may cause a variety of problems, from corrosion to inefficient cooling, pressure increases, and compressor failure.

##### 3.1.5 Obstructions

To function efficiently the air inlet and outlet of the skirt condenser must be free of any obstruction, including the bus chassis rail and the bus skirt. Failure to have free air flow will restrict the rate of heat rejection causing a

pressure rise in the system. Excessive pressure may cause cooling inefficiencies and possible compressor failure. The bus skirt must always be cut out when installing a skirt mounted condenser.

##### 3.1.6 Skirt Supports

Whenever a bus skirt support must be removed in order to mount the condenser, the skirt must be resupported by the condenser assembly or by attaching an alternate skirt support. All skirt mounted condenser screens must be flat against the vehicle skirt.

##### 3.1.7 Mounting (Skirt)

All Carrier Transport Air Conditioning condensers are supplied with the proper mounting hardware. Never substitute mounting hardware. Always insure that the skirt mounted condensers are mounted on a flat surface and are level. Carrier highly recommends that "OEM's (original equipment manufacturers) provide condenser mounting brackets in order that the bus floor does not have to be drilled through when mounting/installing the skirt condenser.

##### 3.1.8 Mounting (Rooftop)

When mounting a roof top condenser, alterations must be made to the bus roof. The installation instructions include sealing instructions which must be followed. Failure to follow these instructions will allow water to enter the passenger compartment.

##### 3.1.9 Voltage

Carrier Transport Air Conditioning condensers are designed to operate efficiently at 12.5 and 25 Volts respectively. Condensers operating at less than the required voltage will cause the fans to run slower and may cause pressure buildup and possible compressor failure.

### 3.2 CONDENSERS

Condensers are normally located on the outside of the vehicle. Their primary function is to reject heat absorbed by the refrigerant from the passenger compartment to the outside air. Condensers are normally located on the

vehicle skirt or on the roof. If space in the vehicle skirt is a problem, the CM-2 and CM-3 can be stacked on each other with a kit available from Carrier Transport Air Conditioning (Refer to paragraph 3.7) Carrier Transport Air Conditioning condenser assemblies are listed in Table 1-5.

**Table 3-1 CONDENSERS (Used With GEN 4 And GEN 5 Series)**

Component	Type	CFM (Approx)	Amps	Weight	BTU Heat Rejection
CM-2	SKT MT	1600	14@12.5V 16@25V	66 Lbs.	57,000
CM-3	SKT MT	2400	21@12.5V 24@25V	76 Lbs.	76,000
CM-4	SKT OR RF MT	1300	13@12.5V	59 Lbs.	43,000
CM-5	SKT MT	6000	41@24V	202 Lbs.	162,000
CM-7	RF MT	1950	21@12.5V 12@25V	87 Lbs.	76,000
CM-11	RF MT	1300	13@12.5V	77 Lbs.	57,000
KR-4	RF MT	3500	44@12.5V 22@25V	187 Lbs.	130,000
CM-14	SKT MT	1800	27.5@12.5V 30@25V	95 Lbs.	85,000
CM-2 STKD (2 ea)	SKT MT	3200	30@12.5V	144 Lbs.	114,000
CM-3 STKD (2 ea)	SKT MT	4800	45@12.5V	168 Lbs.	152,000

Legend:

- CM - Condenser Module
- KR - Rooftop (4 Fan)
- RF - Roof Mounted
- SKT - Skirt Mounted
- STKD - Stacked

### 3.3 CM-2, CM-3, CM-4, CM-5, & CM-14 SKIRT-MOUNTED CONDENSER ASSEMBLIES

The Carrier Transport Air Conditioning Condensers listed in paragraph 3.3 are designed so they can easily be installed in the skirt of a bus, while other condenser assemblies are mounted on the bus roof.

Check the location selected under the bus for any obstacles that might interfere with the proper installation of the condenser assembly.

Using the dimensions listed in Table 2-1, determine that the condenser assembly will fit safely and securely in the desired location.

**Table 3-2 SKIRT MOUNTED CONDENSERS**

Condenser	A (width)	B (height)	C (depth)
CM-2	35.75 inch	10.312 inch	15.75 inch
CM-3	48.0 inch	10.312 inch	15.75 inch
CM-4	39.0 inch	8.38 inch	14.50 inch
CM-5	87.5 inch	15.25 inch	15.281 inch
CM-14	61.0 Inch	10.37 Inch	15.75 Inch

To install the skirt mounted condenser assemblies utilize the following installation procedures:

- a. Unpack the condenser and check for obvious damage.
- b. Make a condenser mounting template from cardboard or other thin material.

- c. Lay condenser upside down on the template material.
- d. Align the front of the condenser with the straight edge of the template material.
- e. Mark all of the oblong mounting holes located in the front and rear of the condenser assembly.
- f. Mark outer edges of the condenser assembly on to the template material.
- g. Remove condenser from template material and cut-out template and oblong mounting holes.
- h. Mark center of template.
- i. Using the condenser template under the vehicle, find the optimum location between the front and rear wheels of the vehicle and mark the mounting holes.

**Note**

The condenser assembly should contact as many of the floor supports (stringers) as possible, while hitting the least amount of skirt supports.

**Note**

Always attempt to use at least one of the vehicles floor supports (stringers) to mount the condenser assembly.

- j. Drill pilot holes up through the bus (vehicle) floor.

**Caution**

**Make sure there is nothing installed where you are going to drill through the bus floor.**

- k. Using the pilot holes, drill 7/16 inch holes through the bus floor or stringers. See Figure 3-1.

**NOTE**

To safely attach/mount the CM-2 it will require a minimum of 4 bolts, while the CM-3 requires 6 bolts.

**NOTE**

Block spacers or jam-nuts may be required if the condenser mounting area is not tight against the bus stringers. See Figure 3-3.

- l. Mount the condenser using 3/8 inch diameter hardware. See Figure 3-2.
- m. Install grill/screen on condenser assembly or skirt of bus, depending on application.
- n. Connect discharge and liquid lines. Refer to Section 4, hose routing.
- o. Connect electrical harness to condenser. Refer to Section 5, electrical.



Figure 3-1 3/8 Inch Carriage Bolts Thru Floor

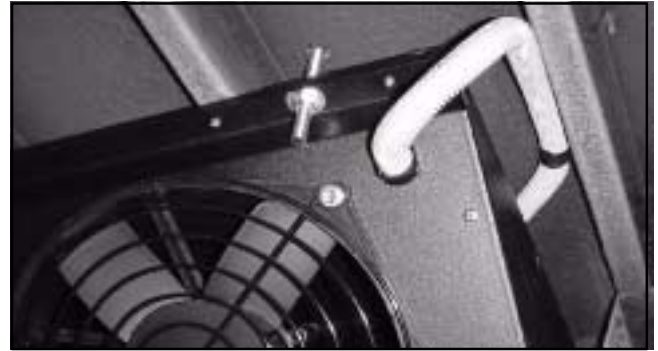

Figure 3-2 Condenser Mounted With Hardware

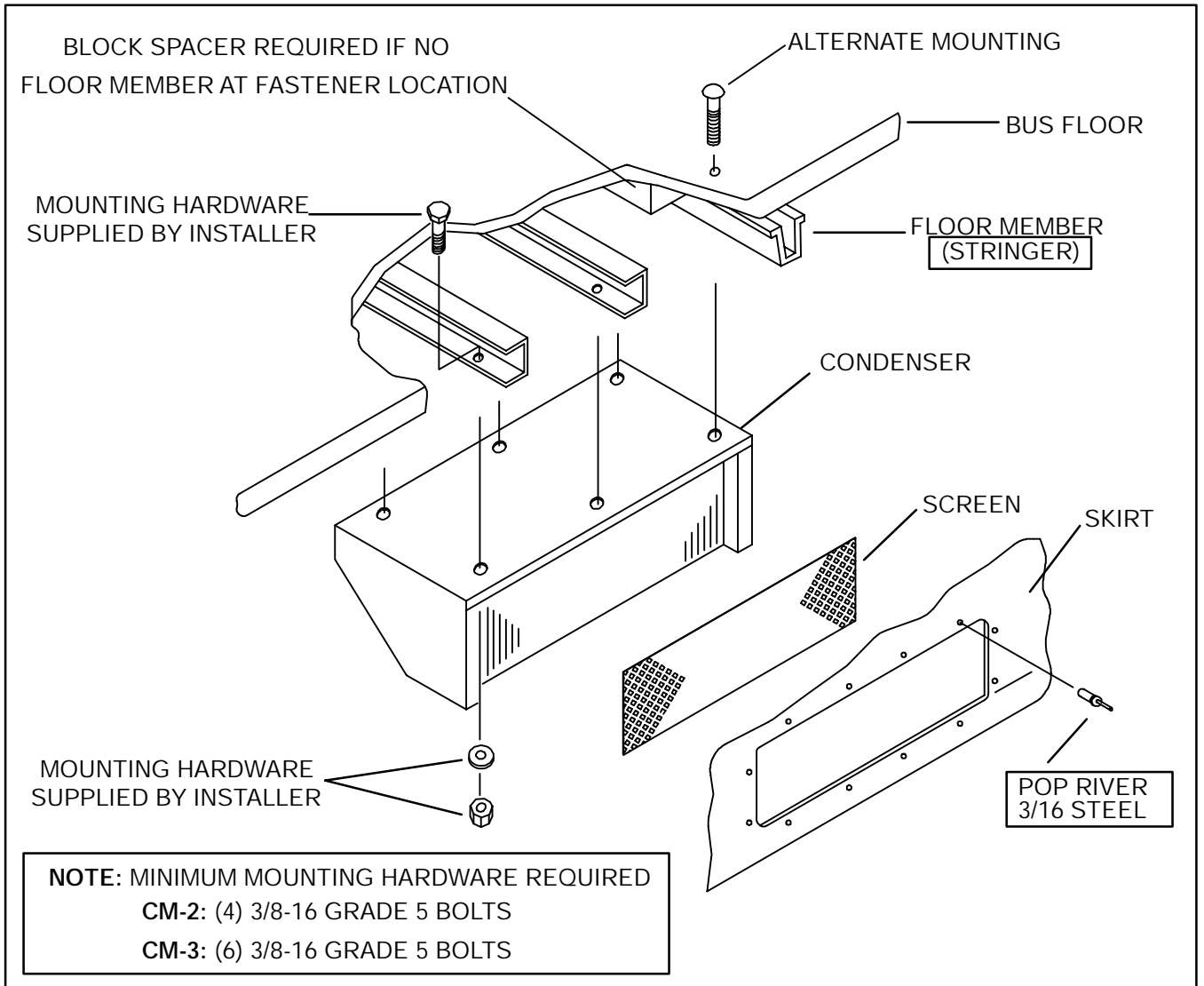

Figure 3-3 Installation Drawing (Typical Skirt Mounted)



Figure 3-4 CM-3 Condenser Mounting (Typical)



Figure 3-5 CM-2 Condenser Mounted on an Extended Roof Van (Custom)

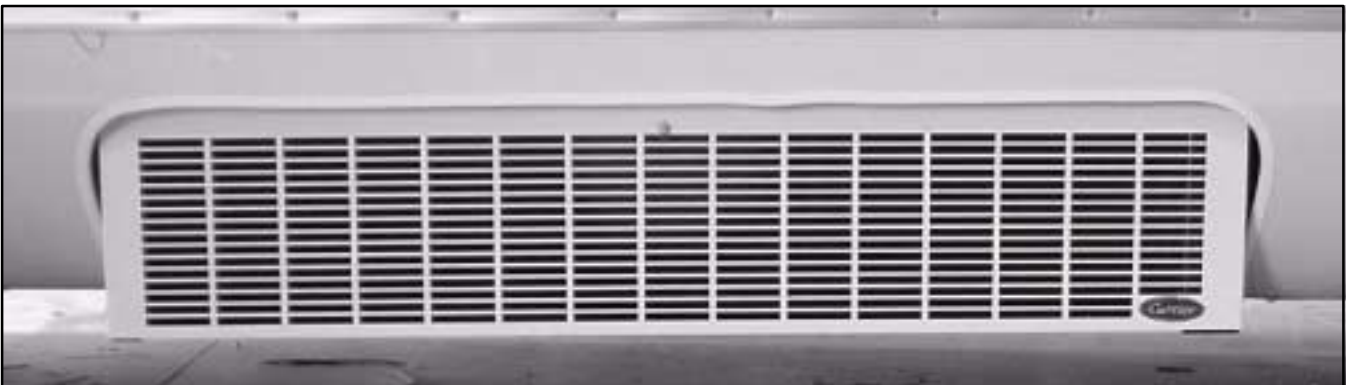

Figure 3-6 CM-3 Mounted In Cut-A-Way Chassis

### 3.4 CM-5 CONDENSER

The Carrier Transport Air Conditioning CM-5 Condenser is designed to be installed in the skirt of the bus.

To install the CM-5 Condenser utilize the installation procedures found in paragraph 3.3.

Refer to the installation drawing enclosed with the condenser or see Figure 3-7.

#### Note

Because of the size and weight of the CM-5 condenser assembly, ten (10) bolts are required to safely install it to the bus floor stringers, Five (5) in the front and (5) in the rear.

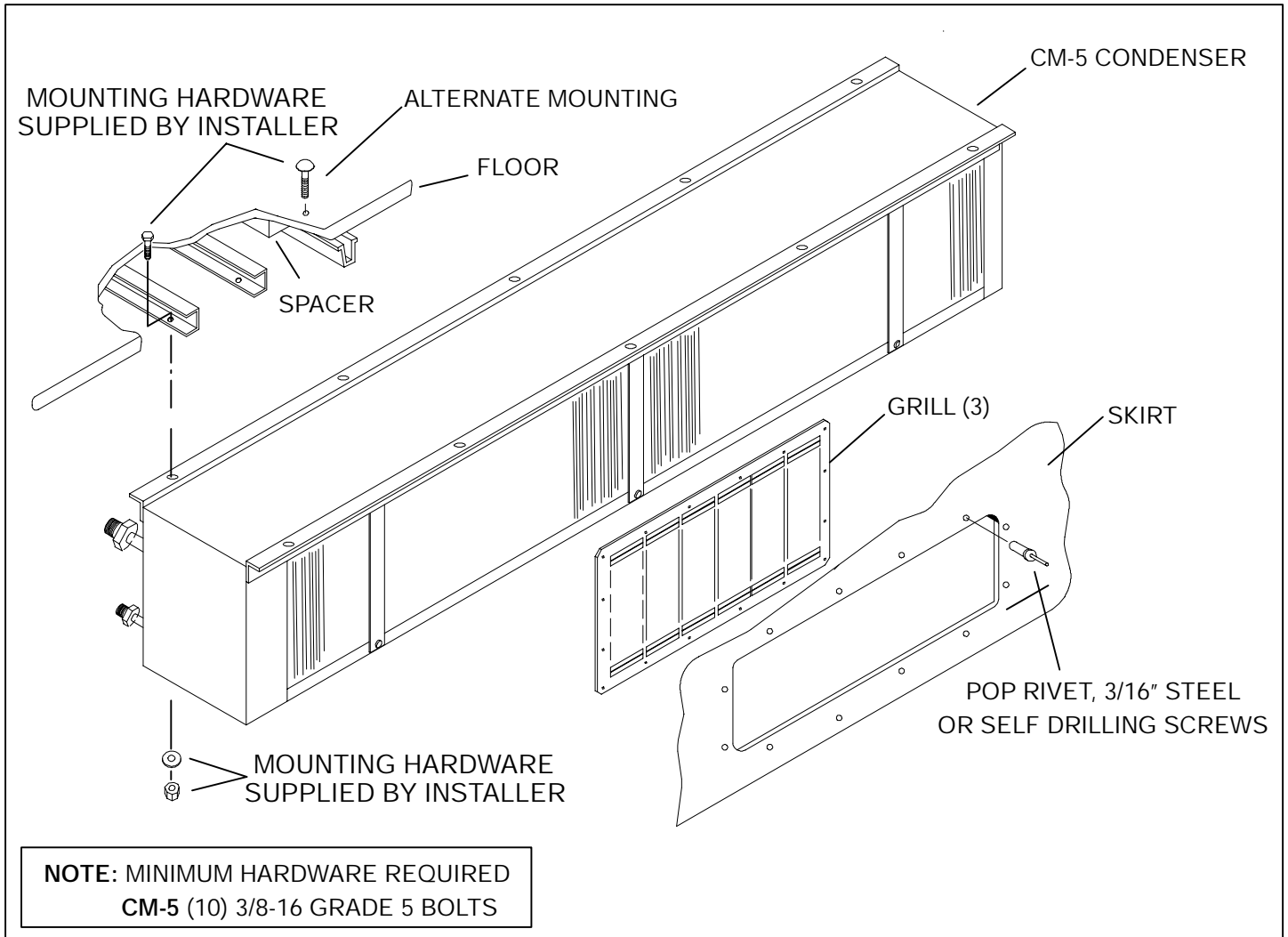

Figure 3-7 CM-5 Installation Drawing

### 3.5 Cm-7, CM-11 ROOFTOP CONDENSER ASSEMBLIES

The Carrier Transport Air Conditioning CM-7 & CM-11 condensers are designed to be installed on the roof of the bus.

To install a rooftop condensers utilize the following installation procedures:

- a. Select a location on the bus roof where the mounting channels will span at least two roof bows.

#### Note

The ideal location will be close to the evaporator inside the bus as well as spanning two roof bows.

- b. Remove the rooftop condenser from the shipping box. Locate the two mounting channels, 4 mounting feet and mounting hardware.
- c. Remove rooftop cover. Install four mounting feet with inclosed hardware. Refer to inclosed installation drawing or see Figure 3-8.

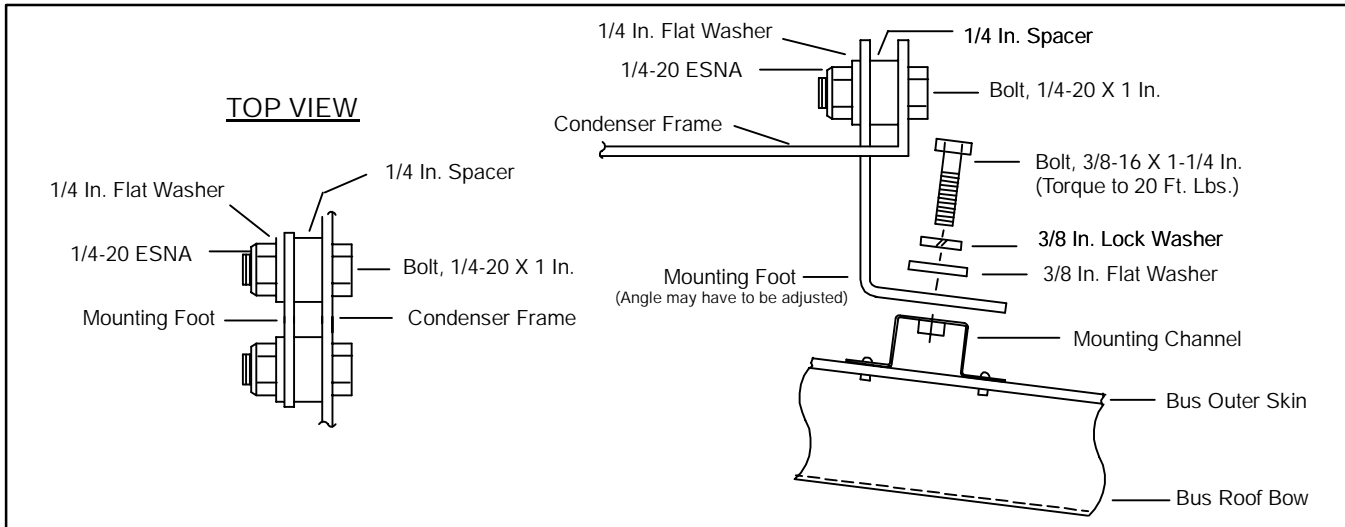

**Figure 3-8 Installing Mounting Feet & Mounting Channels**

- d. Install the two mounting channels to the mounting feet with the enclosed hardware.

- e. Carefully place the condenser at the predetermined location on the bus roof. Center the condenser side-to-side on the bus roof.

#### Note

Do not tighten the mounting hardware at this time. You may have to make adjustments to the mounting feet and rails later.

- f. Trace around both mounting channels.

- g. Mark where the feed-thru-plate will be located. This is where the discharge and liquid line will be connected. Refer to the enclosed installation drawing or see Figure 3-9.

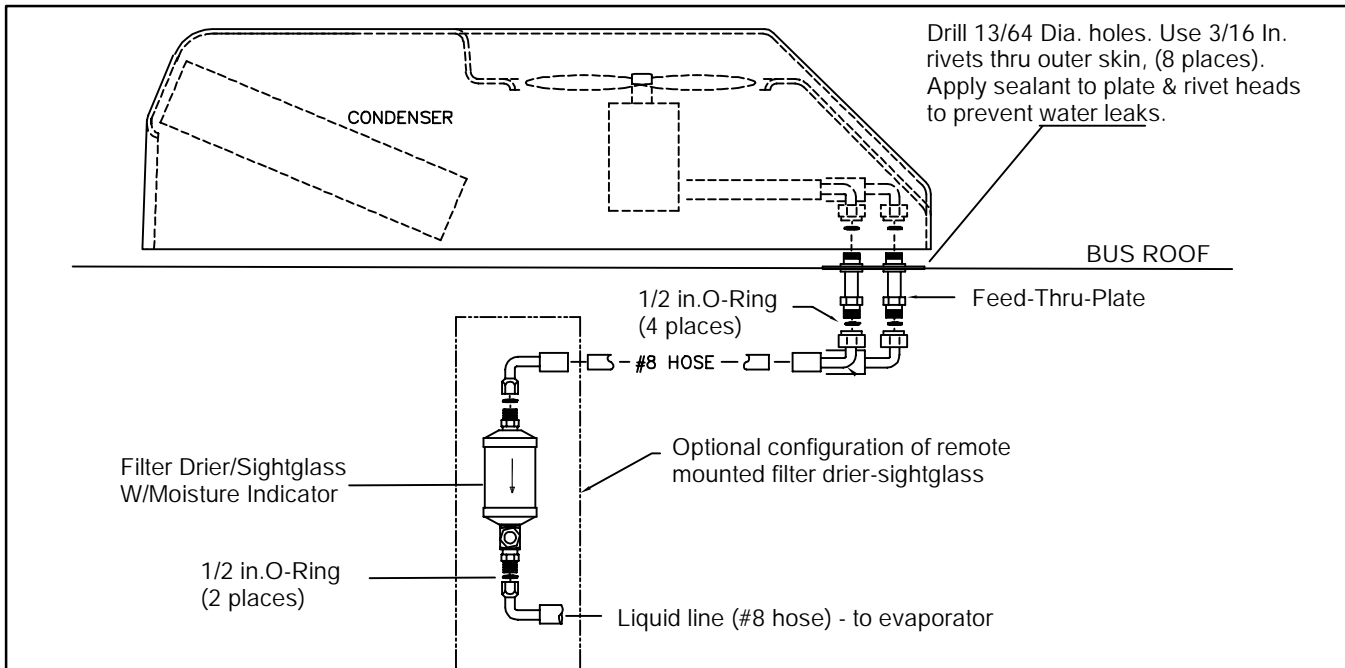

**Figure 3-9 Attaching To Feed-Thru-Plate & Remote Filter Drier**

- h. Remove mounting channels from condenser mounting feet.
- i. Drill 13/64 In. Dia. holes thru the bus roof outer skin and roof bows using the mounting channel holes as a guide. See Figure 3-10.

**Note**

It is recommended that a drill stop be used when drilling through the bus roof.

- j. Apply sealant around all the holes and the mounting channels. Place the channels on the bus roof.

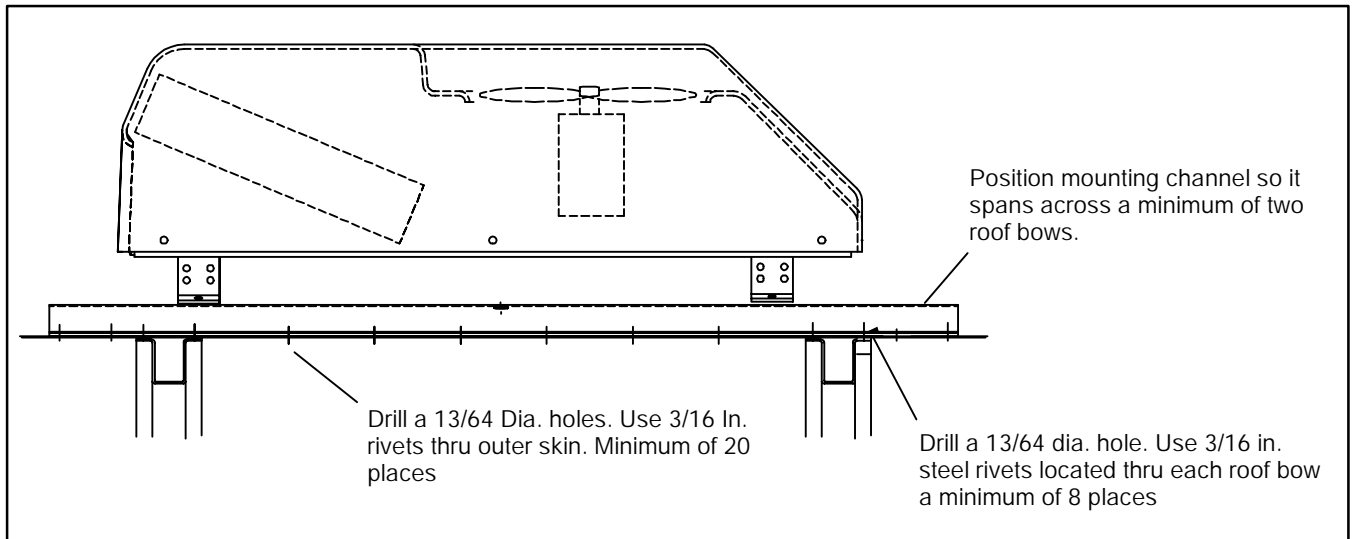

**Figure 3-10 Attaching Mounting Channels To Bus Roof**

- k. Using 3/16 In. Dia. steel rivets, attach the mounting channels to the bus roof.
- l. Where previously marked carefully cut a 3 X 4 Inch hole thru the bus roof and ceiling. This is where the feed-thru-plate will be attached.
- m. Place the feed-thru-plate over the cut-out. Modifications may be needed in order for the plate to fit properly.
- n. Drill 13/64 In. Dia. holes in the bus roof using the holes in the feed-thru-plate as a guide. Use all 8 holes.
- o. Apply sealant around all the holes and the plate.
- p. Using 3/16 In. Dia. steel rivets, attach the feed-thru-plate to the bus roof.
- q. Seal around the feed-thru-plate and the mounting channels. Apply sealant to all the rivet heads to prevent water leaks.

**Note**

The mounting foot angle may have to be adjusted in order that it sits flat on the mounting channels. See Figure 3-8.

- r. Place the condenser back on to the mounting channels. The center of the condenser must be close to the bus roof but not touching it. Adjust the mounting legs up or down for the correct height. Refer to the installation instructions enclosed or see Figure 3-11.

**Note**

Remember to lubricate all fittings, O-Rings, and refrigerant hose with mineral oil before attaching components. All refrigerant O-Ring fittings must be torqued to 30 ft. lbs.

- s. Connect the condenser discharge and liquid lines to the feed-thru-plate fittings.
- t. Securely mount (clamp) the filter drier/sightglass assembly to the ceiling at the rear of the evaporator assembly.

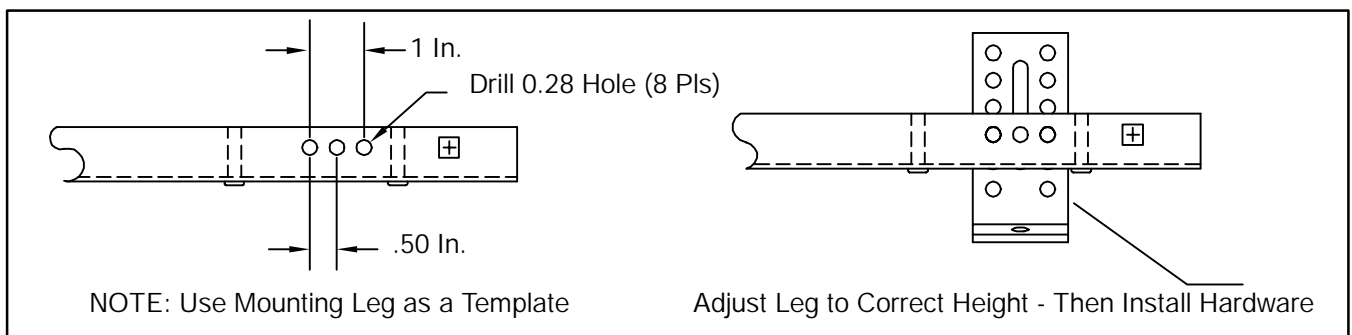

**Figure 3-11 Adjusting Mounting Foot Height**



- u. Assemble, then attach liquid lines from the remote filter drier/sightglass assembly to the liquid line fitting on the feed-thru-plate and the evaporator assembly (See Figure 3-9).
- v. Route suction line from the evaporator and discharge line from the condenser per instructions provided in Section 4, Hose Routing.

**Note**

Route the condenser electrical harness through the feed-thru-plate before bolting on the condenser cover.

- w. Bolt rooftop cover on to rooftop frame with hardware supplied.
- x. Clean condenser cover with a mild cleaning solution and clear all debris from the roof of the bus.

**3.5.1 Connecting to Side-Mounted Evaporators**

The preceding steps are for connecting a rooftop condenser assembly (CM-7 or CM-11) to a rear mounted evaporator assembly. The standard feed-thru-plate should not be used with side mounted evaporators. Refrigerant hoses should be routed between the inner and outer skins of the bus ceiling and roof. When connecting to side mounted evaporators utilize the following procedures:

- a. Follow steps a. through f. from paragraph 3.5.

**Note**

When drilling into the bus ceiling and pulling the refrigerant hoses, care must be taken to remove as little insulation as possible from the bus ceiling.

- b. Mark where the feed-thru-plate would normally be located and cut a 4-1/2 In. hole in roof skin only.
- c. Cut 4-1/2 In hole behind the side mounted evaporator, or, if ducted system, within the duct area.
- d. Use a fish-tape or wire to pull the liquid and discharge lines up to the condenser assembly from inside the bus.

**Note**

Both inside and outside cut-outs must be protected with trim-lock or similar material to help keep the refrigerant hoses and harness from chaffing.

- e. Using the optional hose cover transition (Part # 58-62028-00) allows for a smooth transition from the bus skin to the condenser assembly's liquid and discharge hook-ups, plus it is easier to seal against water leaks.
- f. If the optional hose cover transition (see Figure 3-12) is not used, the roof hole must be sealed to prevent water leaks.
- g. Drill a 1-1/8 In. Dia. hole in the hose cover for the #8 Quick-Click refrigerant hose. Push grommet part # 58-00065-36 into the hole (see Figure 3-12).
- h. Drill a 1-3/8 In. Dia. hole in the hose cover for the #10 Quick-Click refrigerant hose. Push grommet part #AC801-327 into the hole.
- i. Drill a .81 In. Dia. hole in the hose cover for the condenser harness. Push grommet part #58-00065-22 into the hole.

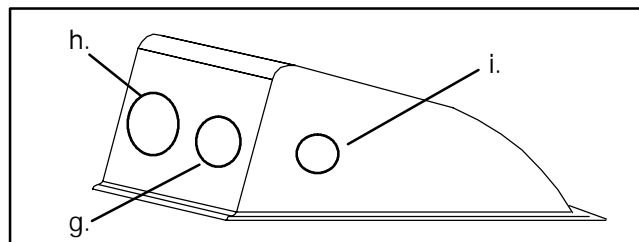

**Figure 3-12 Hose Cover Transition Cut-Outs**

- j. Push the refrigerant hoses and harness through the appropriate grommets in the hose cover transition.
- k. Cut hose to length and install the appropriate Quick-Click fittings. Connect to the condenser liquid and discharge lines.
- l. Center the hose cover transition over the cut-out in the bus roof. Drill 13/64 In. Dia. holes thru the hose cover and bus roof (7 places).

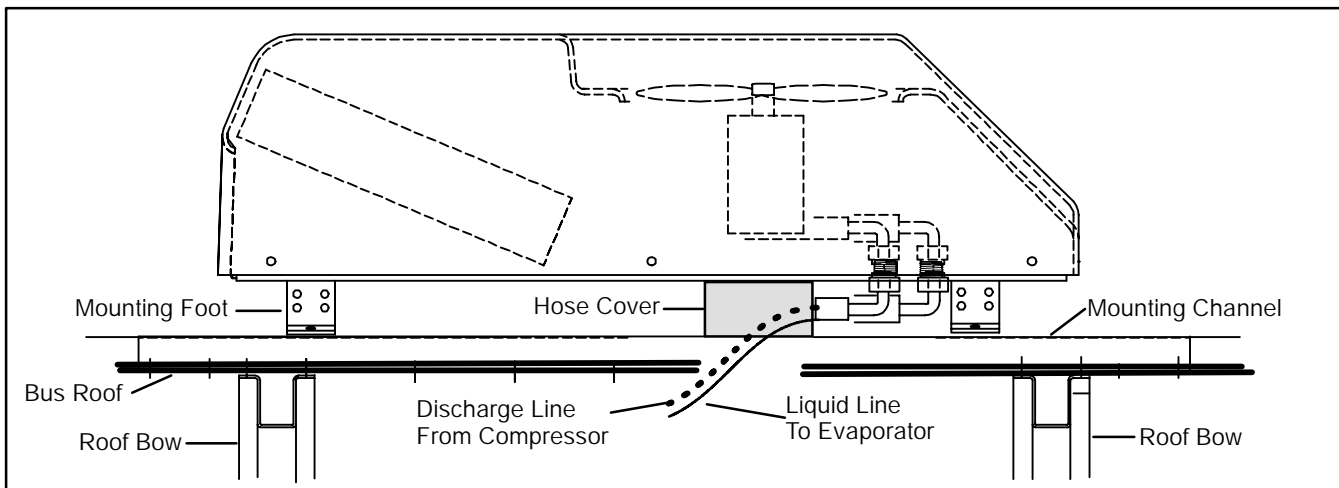

**Figure 3-13 Hose Cover Transition & Refrigerant Hose Connections**

- m. Remove any debris from the hose cover and cut-out.  
Apply a bead of sealant to bottom of the hose cover.  
Rivet hose cover in place with 3/16 India. rivets.
- n. Apply sealant to all the rivet heads and all areas open to the interior to prevent water leakage.
- o. Route suction line from the evaporator and discharge line from the condenser per instructions provided in Section 4, Hose Routing.

**Note**

Connect the electrical harness that was routed through the hose cover transition before bolting on the condenser cover.

- p. Bolt rooftop cover on to rooftop frame with hardware supplied.
- q. Clean condenser cover with a mild cleaning solution and clear all debris from the roof of the bus.

### 3.6 KR-4 ROOFTOP CONDENSER ASSEMBLY

The Carrier Transport Air Conditioning KR-4 condenser is designed to be installed on the roof of the bus.

To install the KR-4 rooftop condenser utilize the following installation procedures:

- a. Select a location on the bus roof where the condenser and/or mounting channels will span three roof bows. (Three (3) are preferred, but never no less than two (2) roof bows.

**Note**

The ideal location will be close to the evaporator inside the bus as well as spanning three roof bows.

- b. Remove the rooftop condenser from the shipping box. Locate the two mounting channels (if used) and mounting hardware.

**Note**

Certain applications will not require the mounting channels due to the contour of the bus roof.

- c. Remove rooftop cover. Install the mounting rails (if used) with the inclosed hardware. Refer to inclosed installation drawing or see Figure 3-14.

**Note**

Do not tighten the mounting channel hardware at this time. They will have to be removed later.

- d. Carefully place the condenser at the predetermined location on the bus roof. Center the condenser side-to-side on the bus roof. Determined if the mounting channels are needed at this time. See Figure 3-15 and Figure 3-16.

**CAUTION**

**This condenser assembly must contact the bus roof in the center. If not, damage will occur.**

**cur. Consult factory as optional mounting may be required.**

- e. Trace around both mounting channels or condenser mounting surface. See Figure 3-14.
- f. Remove mounting channels (if used) from condenser assembly.

**Note**

It is recommended that a drill stop be used when drilling through the bus roof.

**CAUTION**

**All 3/16 and 1/4 In. rivet engagement thickness (grip range) must be between 0.080 and 0.625. Using rivets other than those specified may allow the condenser assembly to come loose from the bus roof.**

- g. If using mounting channels drill (6 places each rail) 13/64 In. Dia. holes thru the bus roof skin using the mounting channel holes as a guide. Apply sealant to the mounting channels or bus roof. Use 3/16 In. Dia. steel rivets to attach mounting channels to bus roof. Drill 17/64 In. Dia. holes thru the mounting channels and bus roof bows. Apply sealant to 1/4 In. Dia. steel rivets and rivet to the roof bows (minimum of two rivets per roof bow). Apply sealant to the rivet heads and around the mounting rails to prevent water leaks. Attach condenser to mounting channels using the enclosed hardware. Torque to 20 Ft. Lbs. Refer to enclosed installation drawing or see Figure 3-17.
- h. If not using mounting channels, remove the condenser assembly to expose outline tracing. Apply sealant where the condenser will be installed. Drill 17/64 In. Dia. holes thru the bus roof skin (6 places each side) and the roof bows (minimum of two rivets per roof bow). Apply sealant to 1/4 In. Dia. steel rivets and rivet to the roof and roof bows. Apply sealant to the rivet heads and around the mounting rails to prevent water leaks. Refer to enclosed installation drawing or see Figure 3-18.

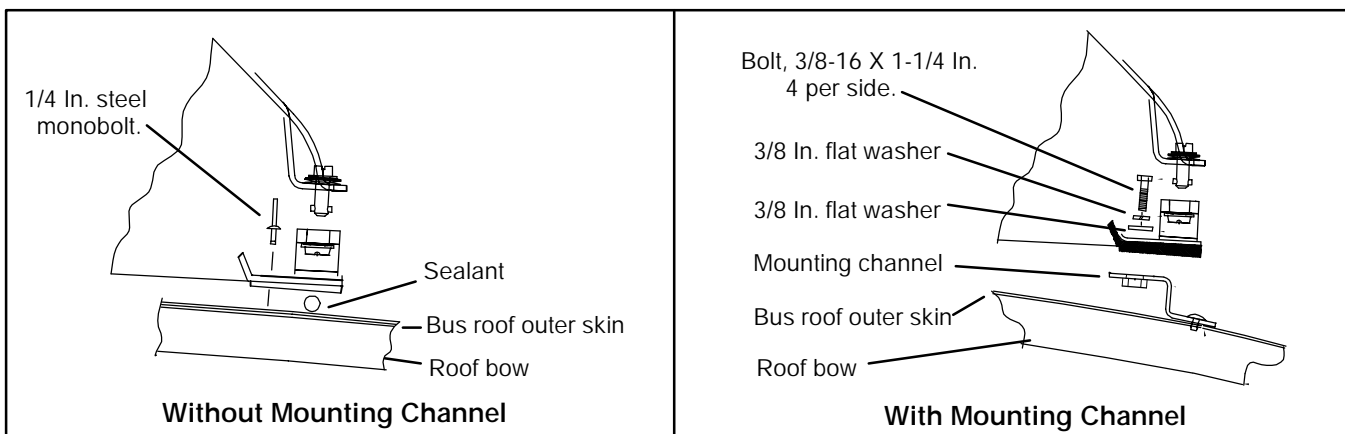

Figure 3-14 Mounting Options

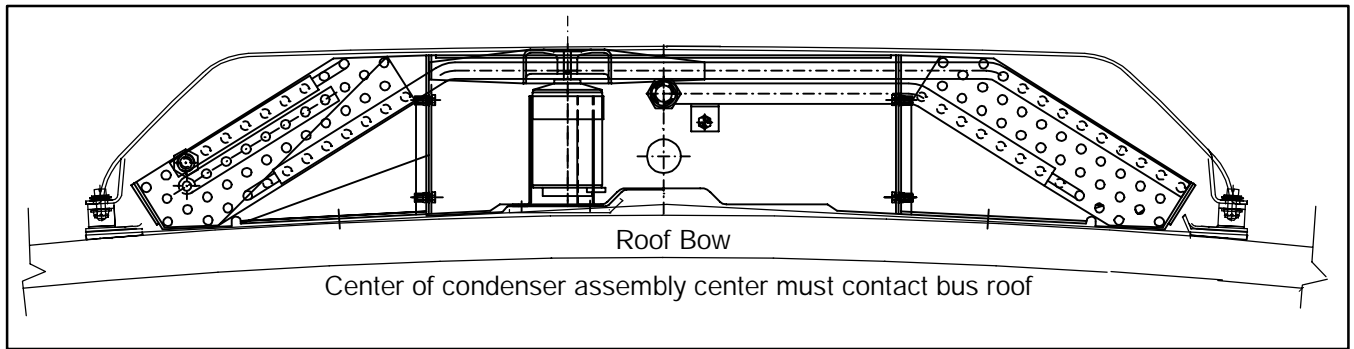

Figure 3-15 Condenser Mounted Without Mounting Channels

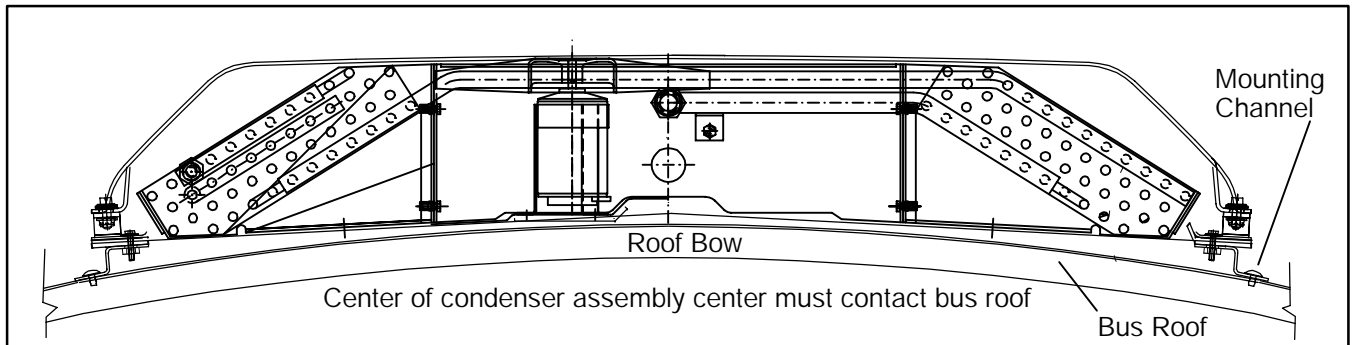

Figure 3-16 Condenser Mounted With Mounting Channels

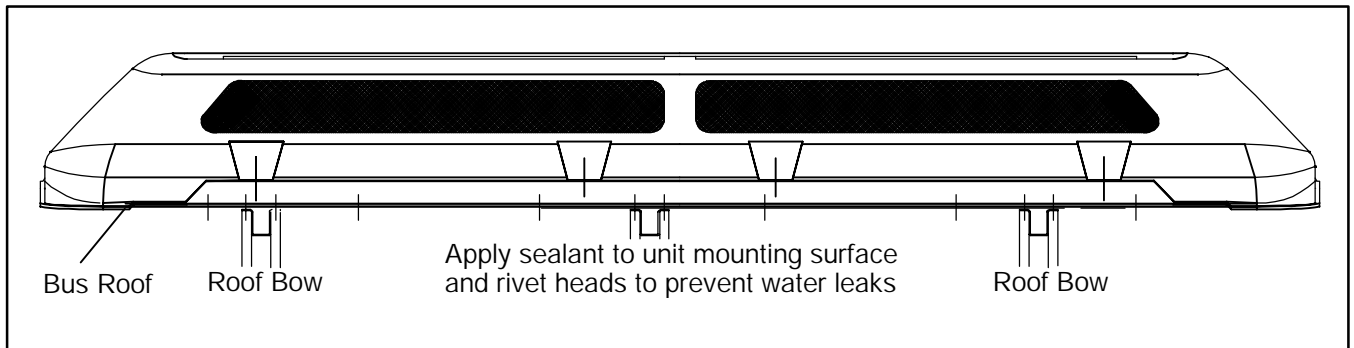

Figure 3-17 Condenser Mounted Without Mounting Channels (Side View)

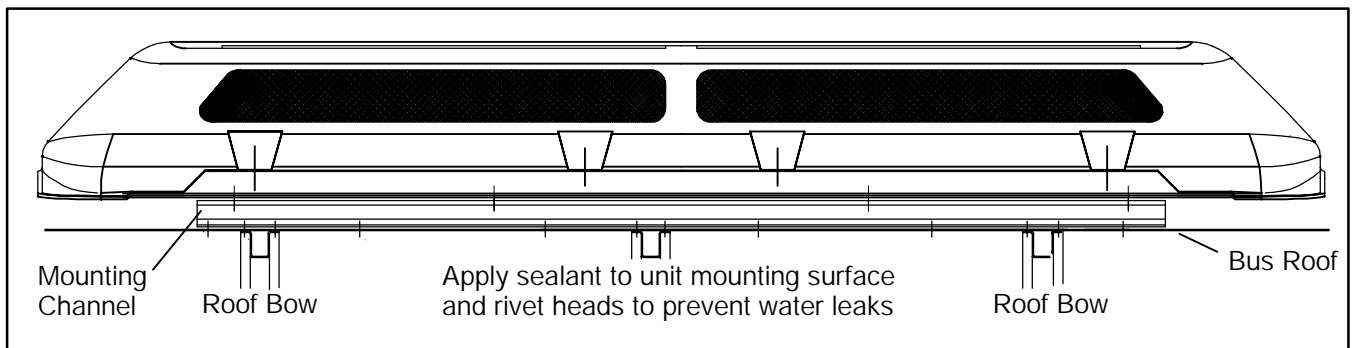

Figure 3-18 Condenser Mounted With Mounting Channels (Side View)

### 3.6.1 Connecting To The Evaporators

When connecting to the evaporator(s) utilize the following procedures:

- a. Condenser assembly inlet and outlet should have been positioned as close to the evaporator assembly as possible (rear or side mount).
- b. Follow procedures in paragraph 3.5 and 3.5.1.

- c. After connecting refrigerant lines and condenser harness(s) install the condenser cover with hardware provided.

- d. Clean condenser cover with a mild cleaning solution and clear all debris from the roof of the bus.

### 3.7 CM-2 AND CM-3 STACKED CONDENSER ASSEMBLIES

The Carrier Transport Air Conditioning stacked condensers are designed to be installed in the skirt of the bus when there is insufficient room for a standard installations.

To install Stacked Condensers utilize the following installation procedures:

#### NOTE

The top and bottom condenser assemblies can be assembled as one then installed as a complete stacked condenser assembly to the bus stringers.

#### CAUTION

Condenser assemblies must be properly installed using graded hardware. The CM-2 condenser assembly requires at least 4 bolts and the CM-3 requires at least 6 bolts.

- a. Install top condenser to the bus stringers (floor) as described in paragraph 3.3
- b. Assemble bottom condenser assembly to the top condenser assembly with the hardware supplied in

the appropriate (2 or 3) stacked condenser kit. Refer to the enclosed installation drawing or Figure 3-19 and Figure 3-20.

- c. Place air inlet stiffener over air inlet bracket and loosely attach to the top condenser assembly. Repeat on other side of assembly.
- d. Loosely attach air outlet bracket to top condenser assembly. Repeat on other side of condenser assembly.
- e. Attach bottom condenser assembly to top assembly using the air inlet stiffener bracket, air outlet brackets, and the required hardware.
- f. Attach block-off plate to both air inlet brackets.
- g. Slide air inlet bracket and block-off plate against the bus skirt.
- h. Tighten all bolts.

#### NOTE

The CM-3 Condenser assembly requires the installation of a front bracket. See Figure 3-20. This bracket helps to support the bottom condenser assembly.

- i. Install condenser screens (2) to the bus skirt, air inlet bracket and block-off plate.

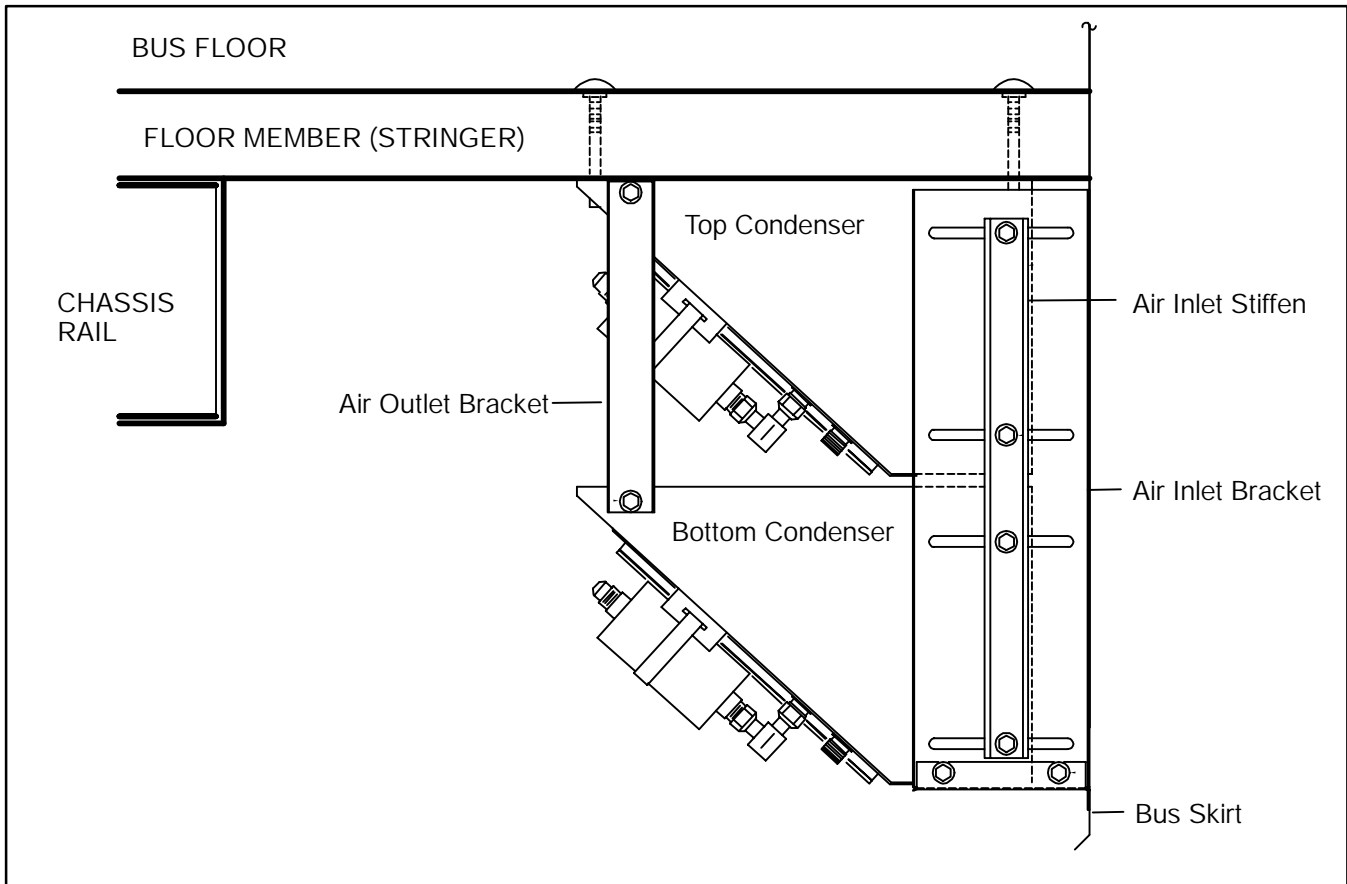

Figure 3-19 Stacked Condenser Assembly (Side View)

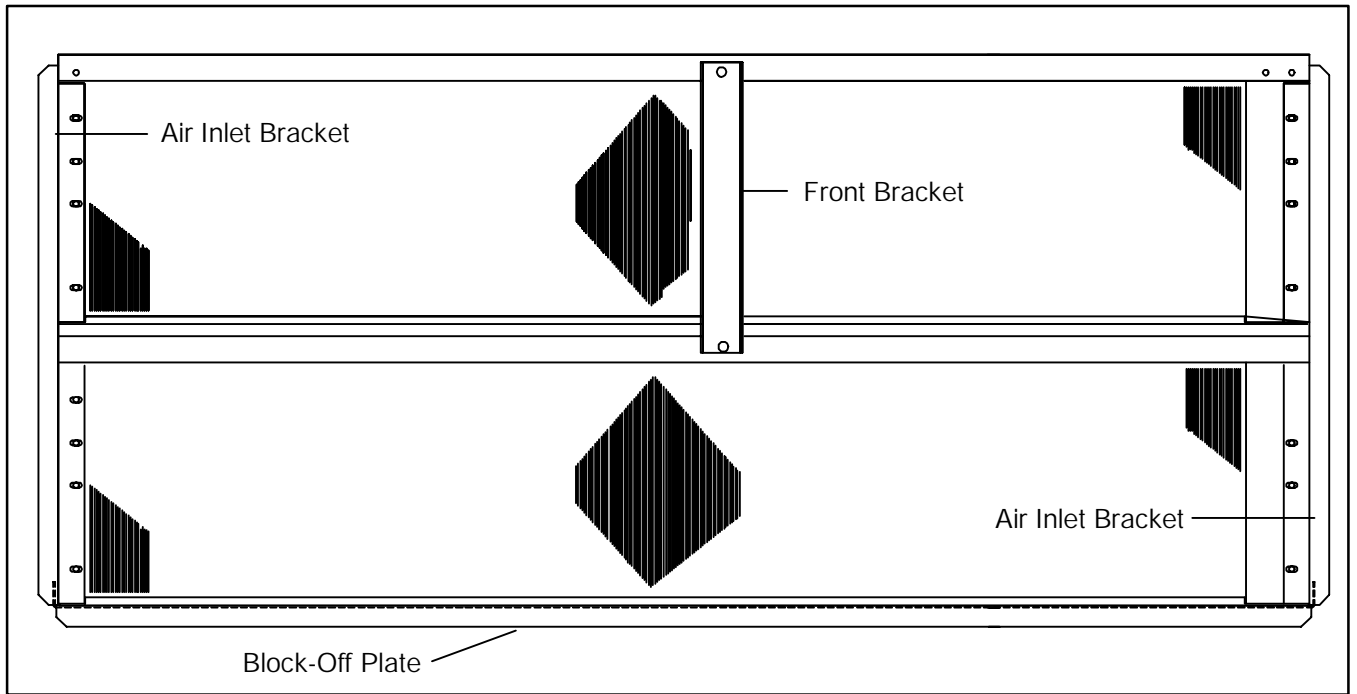

Figure 3-20 Stacked Condenser Assembly (Bus Skirt View)

## SECTION 4

### HOSE ROUTING

#### 4.1 INTRODUCTION

All bus air conditioning systems use a network of refrigerant hose and fittings to connect the major components and carry the refrigerant gas and liquid through the system.

##### 4.1.1 Planning

Extreme care must be used when piping a bus. Plan the routing of the hose prior to the installation, being careful to avoid sources of high heat and sharp edges. If the hose is routed near any heat source it should be protected with a heat-resistant insulation. When hoses are run through sheet metal or other sharp parts of the frame, the hose should be protected by grommets or clamped off in a manner that prevents chaffing. Failure to protect the hose may result in leaks, loss of refrigerant and cooling, and possible compressor damage.

##### 4.1.2 Service Loop

When refrigerant hoses are attached to any component, it is highly recommended that the hoses are not pulled tight. Use a service loop at the compressor and extra hose at other locations to provide strain relief. This will allow the engine and road vibration to be absorbed by the hose and not the fittings. Failure to give strain relief may result in leaks or fractured fittings. Do not, however, leave the extra hose unsupported.

##### 4.1.3 Dual Systems

When a bus has dual (2) systems, care must be taken to assure that the electrical system and hose routing are independent of each other. Connections of the piping for one system to the electrical signals from the other may result in failures to both systems through miscommunication with the pressure switches. Marking both ends of the hose assembly for identification is recommended.

##### 4.1.4 Connection Lubrication (Mineral Oil)

System hose connections, fitting threads, and "O"-Rings must always be lubricated with mineral oil. Never use PAG or POE oils. Failure to lubricate the system "O"-Rings and fitting threads or the use of an improper lubricant may lead to torn seals, local corrosion, and leaks.

##### 4.1.5 Quick-Click Hose & Clamps

It is highly recommended that all installations be performed using Carrier Transportation Air Conditioning "Quick-Click" hose and fittings.

##### 4.1.6 Barrier Type Hose & Fittings

If "Barrier" type hose and fittings are used, it is highly recommended that you review Carrier Transport Air Conditioning Hose Crimping Procedures (Form No. 310-011). The setup, operation and equipment maintenance are all critical. Failure to crimp properly will result in immediate leaks or leaks that become evident due to heat and vibration. When using beadlock type fittings it is critical to have initial interference between the hose inside diameter and fitting tube outside diameter. Use of a combination that has clearance between components will result in a much higher probability of leaks.

#### 4.2 EVAPORATOR HOSE ROUTING-INSIDE THE BUS WALL

Always keep hose capped until ready to connect to a system component (see Figure 4-1).



**Figure 4-1 Quick-Click Hose (Capped)**

Cutaway bus hose routing will normally be routed through the bus floor, up the lower wall (see Figure 4-2), and then behind the upper off-set rear wall. This type of routing must be accomplished before the evaporator is mounted to the bus ceiling. On some buses the hose, harness, and drain lines can be routed (hidden) behind the lower wall also.



**Figure 4-2 Bus With Rear Seat Removed**

1. Determine which side of the vehicle the hoses should be routed; the drivers side or passenger side.

- Determine what route the hoses will take. Take into consideration there are going to be obstacles that the hoses may have to be routed around, such as seats, wheelchair lifts, windows, etc.
- Lay out the hose cover backs in the position that they eventually will be installed, and mark their position (see Figure 4-3). Mark the sides and where they stop at the floor and wall. This will give you an outline where the holes for the hoses should be placed.



**Figure 4-3 Hose Back Positioning**

Before drilling holes for the hoses in the wall or through the floor, make sure there are no electrical harnesses, braces, etc. in the path of the hose routing and hole saw.

- Drill a 3/16 inch pilot hole in the center of where you are going to drill the two 1 1/2 inch holes. This will show you if you can safely cut the two 1 1/2 inch holes in the floor.
- Drill two 1-1/2 inch holes side by side within the hose cover markings (see Figure 4-4).

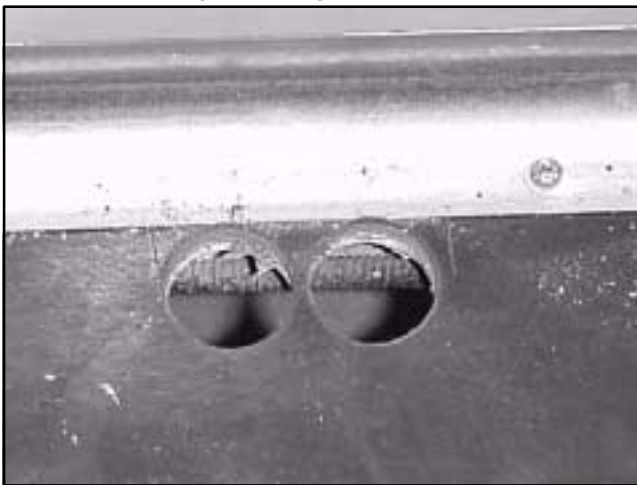

**Figure 4-4 Hole-Saw Cuts in Floor**

- Saw out any material remaining between the two holes, leaving an oblong hole to route the hoses through (see Figure 4-5).

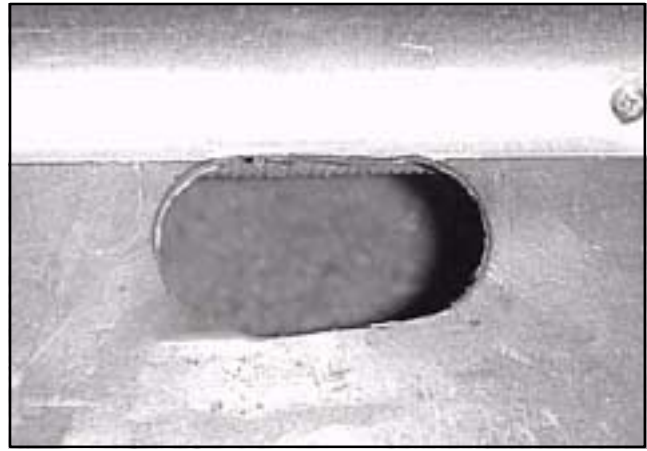

**Figure 4-5 Hole-Saw Cuts Joined**

Repeat steps 1. through 6. to obtain access to the wall or floor, depending which one you start with.



**Figure 4-6 Rear Wall Access**

- Remove any sharp edges from around the holes to prevent hose cutting and/or chaffing.

After holes are drilled, sawed and deburred, you are ready to mount the hose cover backs using common fasteners such as screws or pop rivets (see Figure 4-7 & Figure 4-8).





Figure 4-7 Hose Cover Back



Figure 4-8 Hose Cover Backs On Rear Wall

**Caution**

When drilling into the vehicle wall, always use a drill stop to help protect against damaging any wiring that might be located behind the wall.

**Installation Hint**

To help keep hoses, harness, and drain lines secure and in the center of the hose covers, 3/16 inch holes can be drilled in the hose cover backs. Insert Tie-Wraps through the holes before securing the hose cover backs to the wall (See Figure 4-14).

8. Drill a 3 inch hole in the vehicle wall in order to rout the hoses and harness to the evaporator area.
9. Remove (deburr) any rough edges from around the cut-out.

Using a small piece of "Trim-Loc" or similar material around the cut-out will help protect the hoses and harness from chaffing and/or cutting. (See Figure 4-9).



Figure 4-9 Access Hole With Trim-Lock

10. Route the hoses and harness at this time.



Figure 4-10 Hoses Routed Through Access

Before fastening to the hose cover backs, protect the hoses and harness wherever they go through the floor or wall (see Figure 4-10 & Figure 4-11)

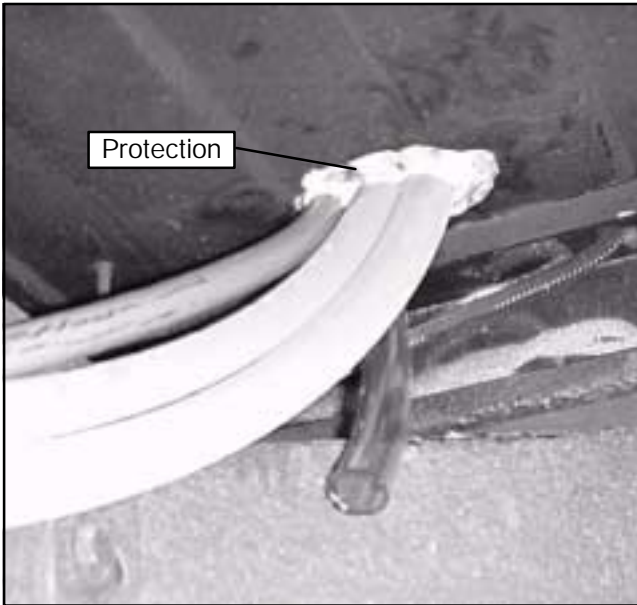

**Figure 4-11 Hoses Routed Through Floor**

A piece of scrap drain hose or heater hose, split down the middle, can be used for protection.

11. After hoses and harness are protected, secure them to the hose cover backs with the Tie-Wraps.



**Figure 4-12 Hoses/Harness Secured With Tie-Wraps To Hose Cover Back**

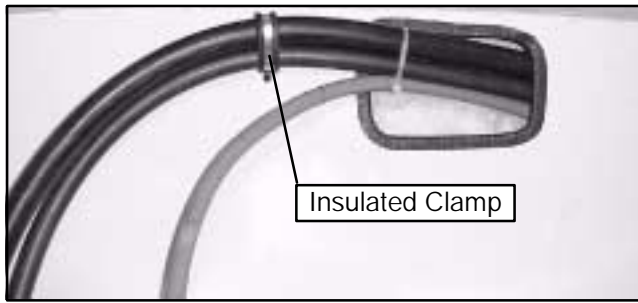

**Figure 4-13 Hose/Harness Clamped to Wall**

At this time the evaporator can be mounted. Refer to Section 2 for the proper procedures for installing a rear mounted evaporator assembly.

12. You may now make the appropriate connection to the evaporator.

Proper hose to fitting clamping is critical. Do not attempt to attach any hose or fitting until you have familiarized yourself with Carrier Transport Air Conditioning Quick-Click hose/fitting crimping procedures.

#### **4.3 EVAPORATOR HOSE ROUTING, OUTSIDE THE BUS WALL**

The evaporator has been previously installed. Refer to Section 2 for the proper procedures for installing a rear mounted evaporator assembly.

Always keep hose capped until ready to connect to a system component (See Figure 4-1).

1. Determine which side of the vehicle the hoses should be routed; the drivers side or passenger side.
2. Determine what route the hoses will take. Take into consideration there are going to be obstacles that the hoses may have to be routed around, such as seats, wheelchair lifts, windows, etc.
3. Lay out the hose cover backs in the position that they eventually will be installed, and mark their position. Mark the sides and where they stop at the floor and wall. This will give you an outline where the holes for the hoses should be placed.

Before drilling holes for the hoses in the wall or through the floor, make sure there are no electrical harnesses, braces, etc. in the path of the hose routing and hole saw.

4. Drill a 3/16 inch pilot hole in the center of where you are going to drill the two 1 1/2 inch holes. This will show you if you can safely cut the two 1 1/2 inch holes in the floor.
5. Drill two 1-1/2 inch holes side by side within the hose cover markings.
6. Saw out any material remaining between the two holes, leaving an oblong hole to route the hoses through.
7. Repeat steps 1. through 6. to obtain access to the wall or floor, depending which one you start with.
8. Remove any sharp edges from around the holes to prevent hose cutting and/or chaffing.
9. After holes are drilled, sawed and deburred, you are ready to mount the hose cover backs using a common fastener such as screws, pop rivets, etc.

When drilling into the vehicle wall, always use a drill stop to help protect against damaging any wiring that might be located behind the wall.

To help keep hoses, harness, and drain lines secure and in the center of the hose covers, 3/16 inch holes can be drilled in the hose cover backs. Insert Tie-Wraps through the holes before securing the hose cover backs to the wall (See Figure 4-14) .

10. Drill a 3 inch hole in the vehicle wall in order to rout the hoses and harness to the evaporator area.
11. Remove (deburr) any rough edges from around the cut-out.
12. Using a small piece of "Trim-Loc" or similar material around the cut-out will help protect the hoses and harness from chaffing and/or cutting. See xxxx
13. Route the hoses and harness at this time.
14. Before fastening to the hose cover backs, protect the hoses and harness wherever they go through the floor or wall. A piece of scrap drain hose or heater hose, split down the middle, can be used for protection.
15. After hoses and harness are protected, secure them to the hose cover backs with the Tie-Wraps.

At this time the evaporator can be mounted. See Section 2 for the proper procedures for installing a rear mounted evaporator assembly.

16. You may now make the appropriate connection to the evaporator.

Proper hose to fitting clamping is critical. Do not attempt to attach any hose or fitting until you have familiarized yourself with Carrier Transport AC's Quick-Click hose/fitting crimping procedures.

#### **4.4 EVAPORATOR HOSE ROUTING, SIDE-MOUNTED**

The side-mounted evaporator should be installed in the desired location. Refer to Section 2 for proper procedures for installing a side-mounted evaporator assembly.

1. Always keep hose capped until ready to connect to a system component.

Side mount hose cover kits are supplied with 45 degree angle pieces and a transition to aid in routing hoses and harnesse down the side of the bus/vehicle.

2. Select a window post nearest the evaporator to route the hoses down. In most cases hoses will need to be routed around seats, emergency exits, etc. Use the 45 degree angles to obtain the proper clearance.
3. Lay out the hose cover backs in the position they will eventually be installed.

Take extra precaution when routing hoses to a side mounted evaporator. You are restricted to a limited amount of space to route the hose. Make sure the hoses do not bend to the point of kinking the hose. This would result in poor system performance and/or failure.

4. Mark where the hose cover back meet the evaporator and the floor. This will give you an outline where the holes for the hoses should be placed.

Before drilling holes for the hoses in the wall or through the floor, make sure there are no electrical harnesses, braces, heater lines, etc. in the path of the hose routing and hole saw.

On many of the larger buses there are heater hose lines with covers running the length of the bus floor. On most applications there is enough room inside the heater hose covers to route the hose, harness, and drain line behind the heater hose. Extreme care must be taken so as not to drill into, cut, or kink the heater lines. This type routing takes a little more time, but makes for a much neater installation.

5. Drill a 3/16 inch pilot hole in the center of where you are going to drill the two 1 1/2 inch holes through the floor. This will show you if you can safely cut the two 1 1/2 inch holes through the floor.
6. Drill the two 1-1/2 inch holes side by side within the hose cover markings.
7. Saw out any material remaining between the two holes, leaving an oblong hole to route the hoses through.
8. Remove any sharp edges from around the holes to prevent hose cutting and/or chaffing.
9. After holes are drilled, sawed and deburred, you are ready to mount the hose cover backs using a common fastener such as screws, pop rivets, etc.

When drilling into the vehicle wall, always use a drill stop to help protect against damaging any wiring that might be located behind the wall.

#### Installation Tip

To help keep hoses, harness, and drain lines secure and in the center of the hose covers, 3/16 inch holes can be drilled in the hose cover backs. Insert Tie-Wraps through the holes before securing the hose cover backs to the wall (see Figure 4-14).

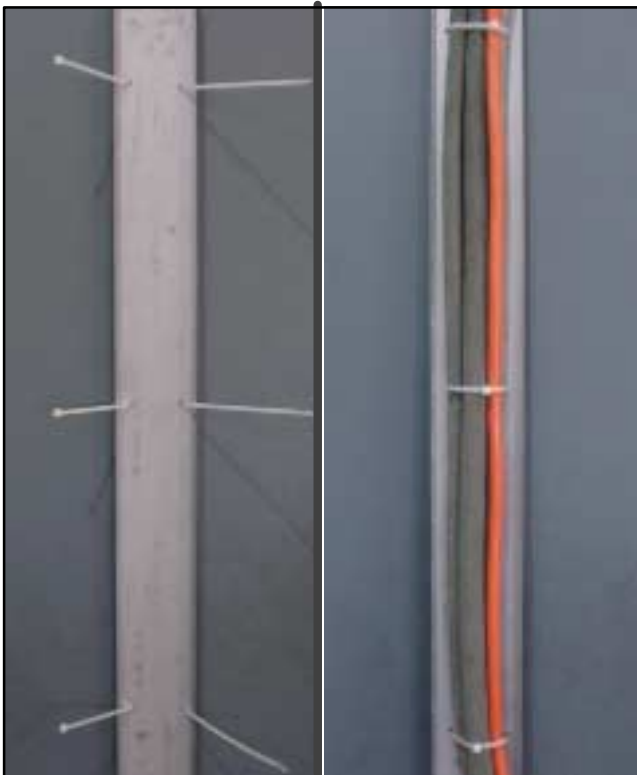

Figure 4-14 Hose Cover Backs W/Tie-Wraps

10. Remove (deburr) any rough edges from around the cut-out.

11. Route the hoses and harness at this time.

Before fastening to the hose cover backs, protect the hoses and harness wherever they go through the bus floor or heater cover.

A piece of scrap drain hose or heater hose, split down the middle, can be used for protection.

12. After hoses and harness are protected, secure them to the hose cover backs with the Tie-Wraps.

13. You may now make the appropriate hose connections to the evaporator.

Properly clamping a fitting to the refrigerant hose is very important. Do not attempt to attach any hose or fitting until you have familiarized yourself with Carrier Transport Air Conditioning Quick-Click hose/fitting clamping procedures.

#### 4.5 CHASSIS HOSE ROUTING

Always keep hose capped until ready to connect to a system component.

Exact routing of hose and harness in the chassis area cannot possibly be covered in detail due to the various manufacturers of vehicles and chassis, as well as many different applications.

Once the hoses are routed from the evaporator area and through the floor of the vehicle, they will have to be routed to the condenser and compressor areas.

Before routing the hose, plan the route the hose and harness will take, avoiding heat sources, sharp or rough areas, moving parts, etc.

Always protect hose and harness where they cross over the vehicle frame or any other place where they are laying on sharp edges (see Figure 4-15 & Figure 4-17) or are near any heat source.

Secure the hoses underneath the vehicle with insulated "P-Clamps". Clamps should be spaced no more than 24 inches apart. Secure the hoses and harness to the vehicles floor supports and/or chassis frame (see Figure 4-15 thru Figure 4-16).



Figure 4-15 Hose Routing (Chassis)



Figure 4-17 Hose Routing (Chassis)



Figure 4-16 Hose Routing (Chassis)



Figure 4-18 Hose Routing (Chassis)

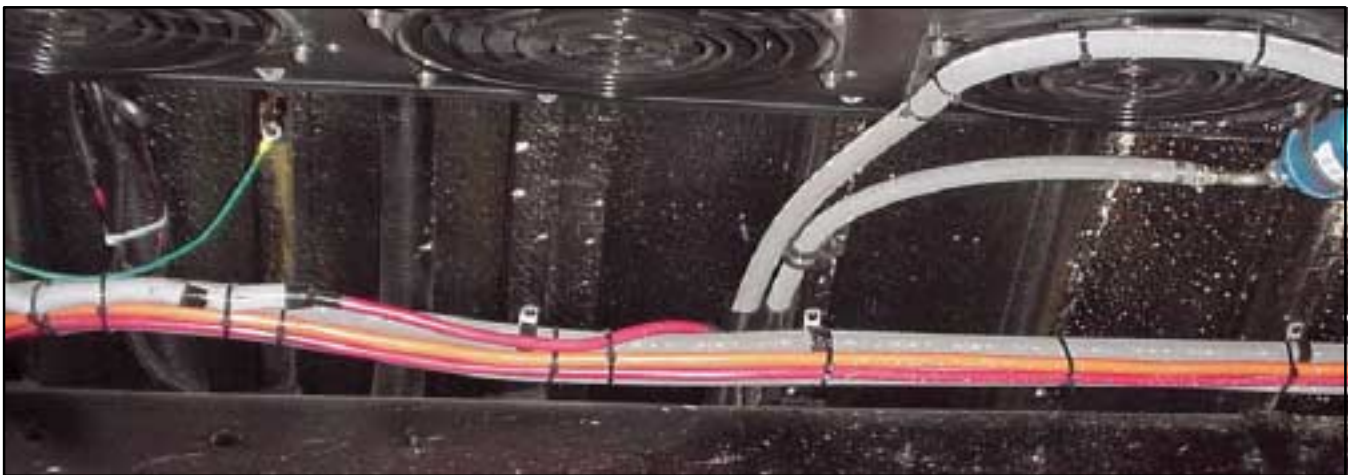

Figure 4-19 Hose Routing (Chassis & Condenser)

#### 4.6 CONDENSER HOSE ROUTING

Always keep hose capped until ready to connect to a system component.

When mounting hose in the condenser area, secure the hose in a manner so that the weight of the hose is not on the condenser fittings.

Always try to leave a service loop in the hose to relieve stress from the condenser fitting and for ease of serviceability.

When making condenser connections, always use caution as you start the fitting onto the condenser. Lubricate the fitting and "O" Ring with mineral oil before making the connection.

Secure hoses in the condenser area with insulated P-Clamps (see Figure 4-19).

Properly clamping a fitting to the refrigerant hose is very important. Do not attempt to attach any hose or fitting until you have familiarized yourself with Carrier Transport Air Conditioning Quick-Click hose/fitting clamping procedures.

#### 4.7 VEHICLE COMPRESSOR HOSE ROUTING

Always keep hose capped until ready to connect to a system component.

When routing hoses in the engine area, you must use extreme caution, due to the many heat sources, sharp edges, and engine movement (See Figure 4-20).

Hoses must be protected with a heat resistant insulation when routed close to the manifold, turbo pipes, or any other hot area of the vehicle engine.



Figure 4-20 Engine Routing (With High & Low In-Line Access Fittings)

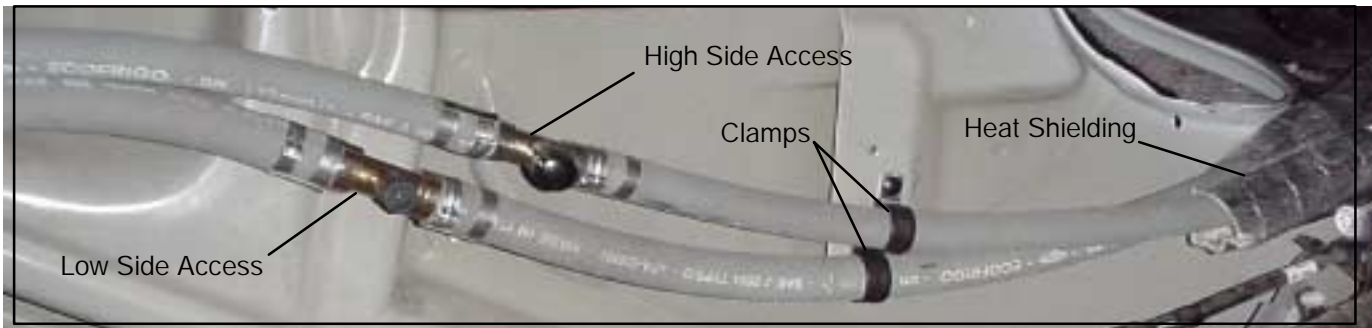

Figure 4-21 Hose Routing - OEM (To & From Engine)

#### Caution

**Never substitute fittings or hose. Follow the piping diagram provided with the system.**

Follow any special instructions on hose routing that may have been supplied with the vehicle compressor mount kit.

Always leave a service loop in the hoses when connecting to the compressor on the vehicles engine. This will allow the hoses to flex with engine movement, taking stress off of the compressor fittings. Failure to relieve stress may result in fittings backing off, leaks, and/or fitting failure.

Secure hoses with insulated P-Clamps whenever possible (See Figure 4-21).

#### CAUTION

**Tie-Wraps may be used to bundle hoses and harnesses, but should never be used to secure hoses to the vehicle.**

When making compressor connections, always use caution as you start the fitting onto the compressor. Lubricate the fitting and "O" Ring with mineral oil before making the connection.

Apply Mineral Oil to all Flare and O-Ring surfaces prior to connecting.

#### CAUTION

**No matter what type of lubricant (oil) used in the system, always use mineral oil to lubricate the O-Rings, and fittings. PAG oils will absorb moisture and become very acidic and corrosive. Mineral oil will not absorb moisture and thus prevent corrosion.**

#### CAUTION

**Always use existing holes in the chassis frame. Never drill holes in the chassis frame.**

#### CAUTION

**Never secure hoses or harnesses to any part of the vehicle fuel system.**

Install all hoses and fittings in a manner that will not adversely affect the fitting torque.

#### 4.8 TORQUE SPECIFICATIONS - REFRIGERANT FITTINGS

All refrigerant hose fitting connections must be torqued to the specifications listed in Table 4-1. Fittings threads and O-Rings must be lubricated with mineral oil, not PAG or POE oils.

Table 4-1 STANDARD TORQUE REQUIREMENTS					
SIZE	TUBE O.D. *	FLARE	O-RING		THREAD **
			STEEL TUBING	ALUM. TUBING	
4	1/4 inch (.250)	11-13 ft./lbs.	30-35 ft./lbs.	5-7 ft./lbs.	7/16
5	3/8 inch (.375)	15-17 ft./lbs.	30-35 ft./lbs.	8-10 ft./lbs.	9/16
6	3/8 inch (.375)	18-20 ft./lbs.	30-35 ft./lbs.	11-13 ft./lbs.	5/8
8	1/2 inch (.500)	36-39 ft./lbs.	30-35 ft./lbs.	15-20 ft./lbs.	3/4
10	5/8 inch (.625)	52-57 ft./lbs.	30-35 ft./lbs.	21-27 ft./lbs.	7/8
12	3/4 inch (.750)	71-79 ft./lbs.	30-35 ft./lbs.	28-33 ft./lbs.	1-1/16

\* The tube O.D. is measured at the point it passes through the nut. \*\* Thread pitch may vary.

#### 4.9 ROOFTOP CONDENSER HOSE ROUTING (CM-7 & CM-11)

Always keep hose capped until ready to connect to a system component.

Hoses should be routed as close to the evaporator as possible. This will ease the routing through the roof and to the condenser.

When making condenser connections, always use caution as you start the fitting onto the condenser. Lubricate the fitting and "O" Ring with mineral oil before making the connection.

Properly clamping a fitting to the refrigerant hose is very important. Do not attempt to attach any hose or fitting until you have familiarized yourself with Carrier Transport Air Conditioning Quick-Click hose/fitting clamping procedures.

#### 4.10 AUXILIARY HEATER HOSE ROUTING (GENERIC)

Carrier Transport Air Conditioning does not supply heater hose for connecting to a Carrier Transport Air Conditioning supplied heater coil.

The following general guidelines have been established to aid in connecting an auxiliary heater coil to the vehicles heating system.

#### 4.11 PIPING DIAGRAMS

While all piping diagrams could not be included in this manual, some of the more common installations have.

Use only approved OEM type heater hose or its equivalent.

Use only worm-gear drive type hose clamps on heater hose.

Never secure heater hose to the transmission dip stick tube or on to any fuel system component.

Do not route heater hoses near sharp edges, utilize edge guards to protect against cutting and/or chaffing.

Secure heater hoses with insulated P-clamps.

#### CAUTION

**Tie-Wraps may be used to bundle hoses and harnesses, but should never be used to secure hoses to the vehicle.**

The hot water supply hose should be connected to the lowest part of the heater core.

Minimize air pockets in the system by adding an air bleed-off device at the systems high point.

The use of a positive shut-off valve in the auxiliary hot water supply hose is highly recommended. Any leakage of hot water into the heater core during the air conditioning season will adversely effect the cooling efficiency of the air conditioning system.

Always refer to the detailed piping diagrams furnished with the system you are installing. If your specific piping diagram is not included with your system installation kit, contact Carrier Transport Air Conditioning Technical Support Hot Line at 800-450-2211.

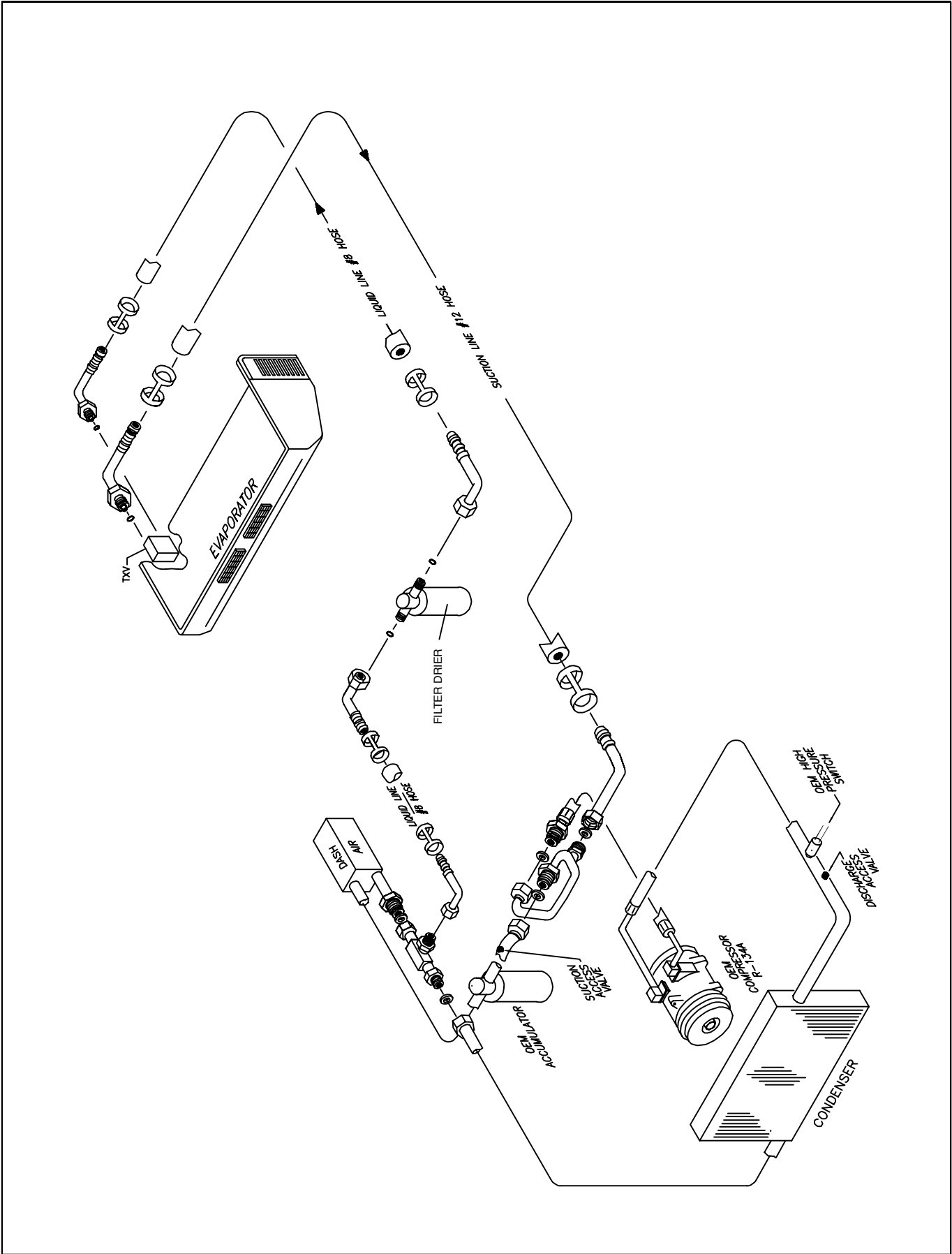

Figure 4-22 Rear Evaporator, OEM Tie-in



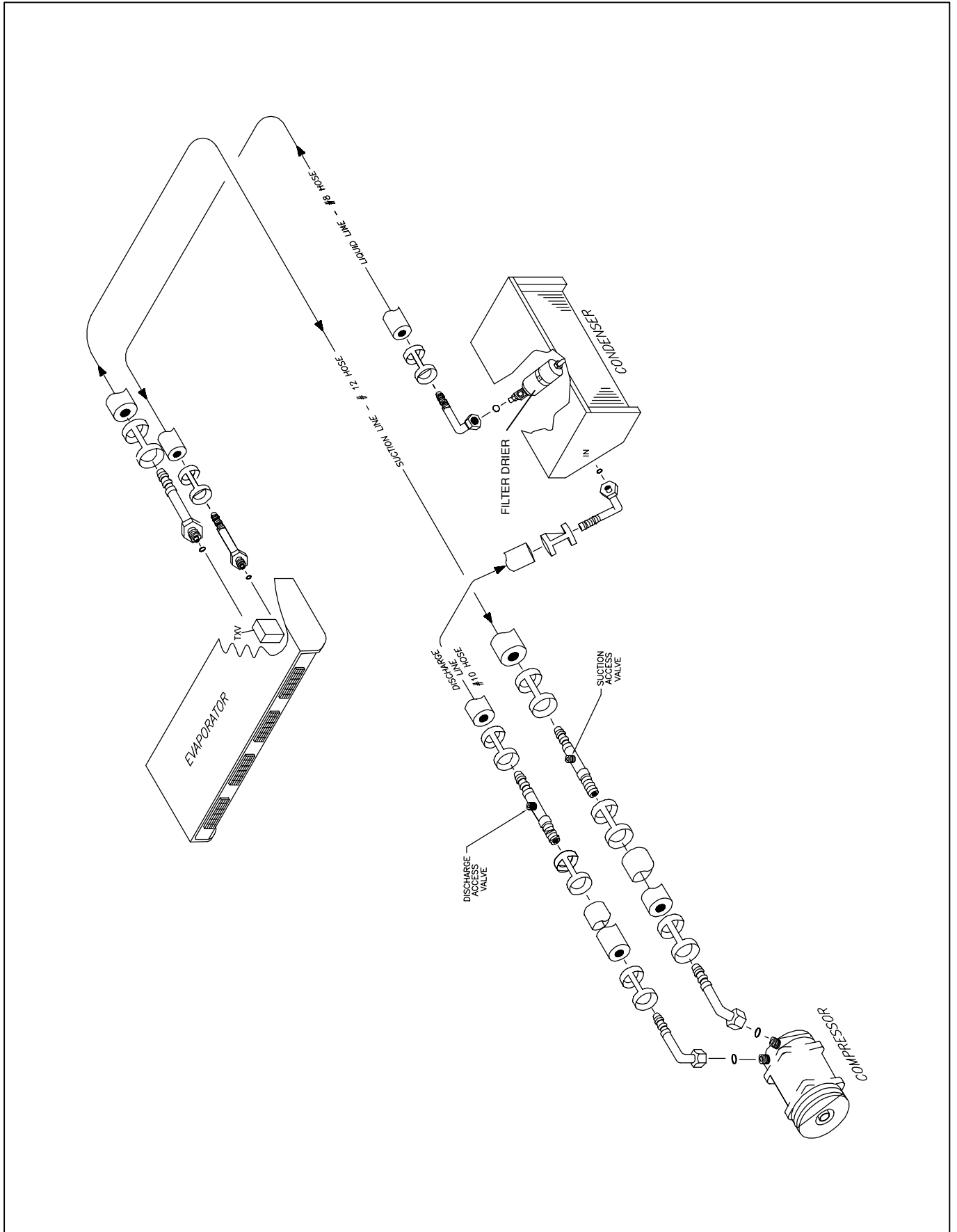

Figure 4-23 Evaporator, Skirt Monuted Condenser and Compressor

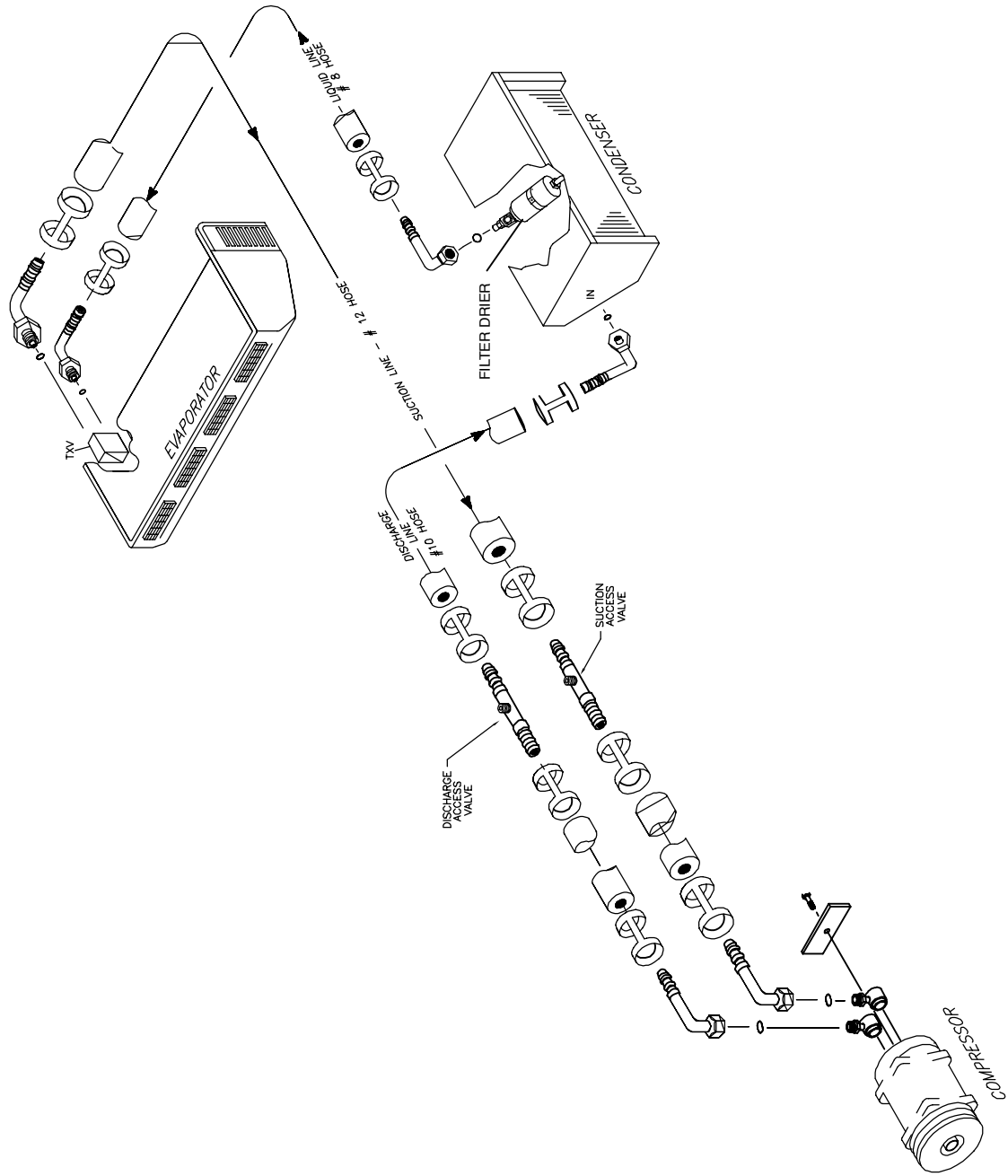

Figure 4-24 Evaporator, Skirt Monuted Condenser and Compressor (AC-322, -332, -442)



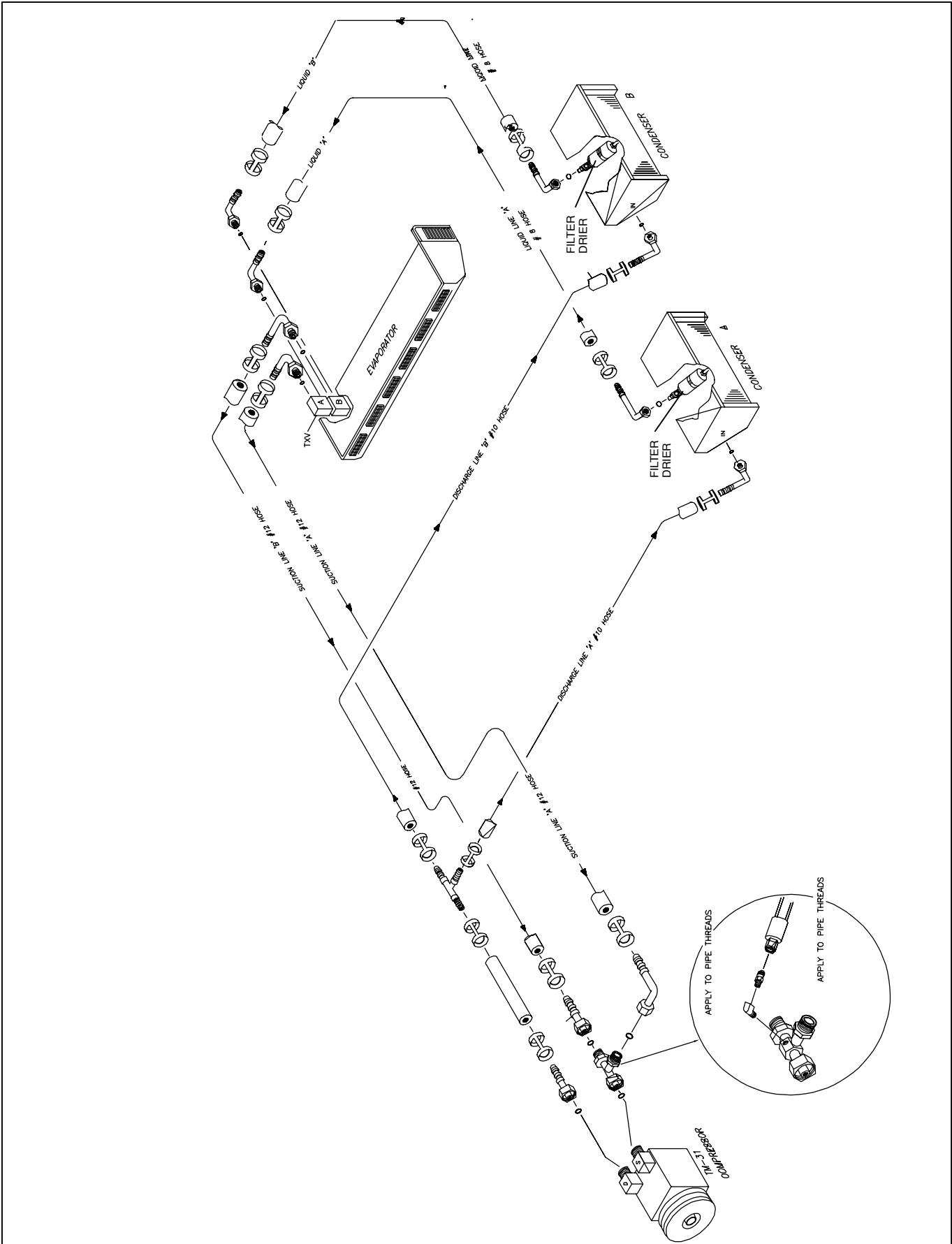

Figure 4-26 EM-3 Evaporator, (2) Skirt Monuted Condensers and TM-31 Compressor (AC-882, -883)

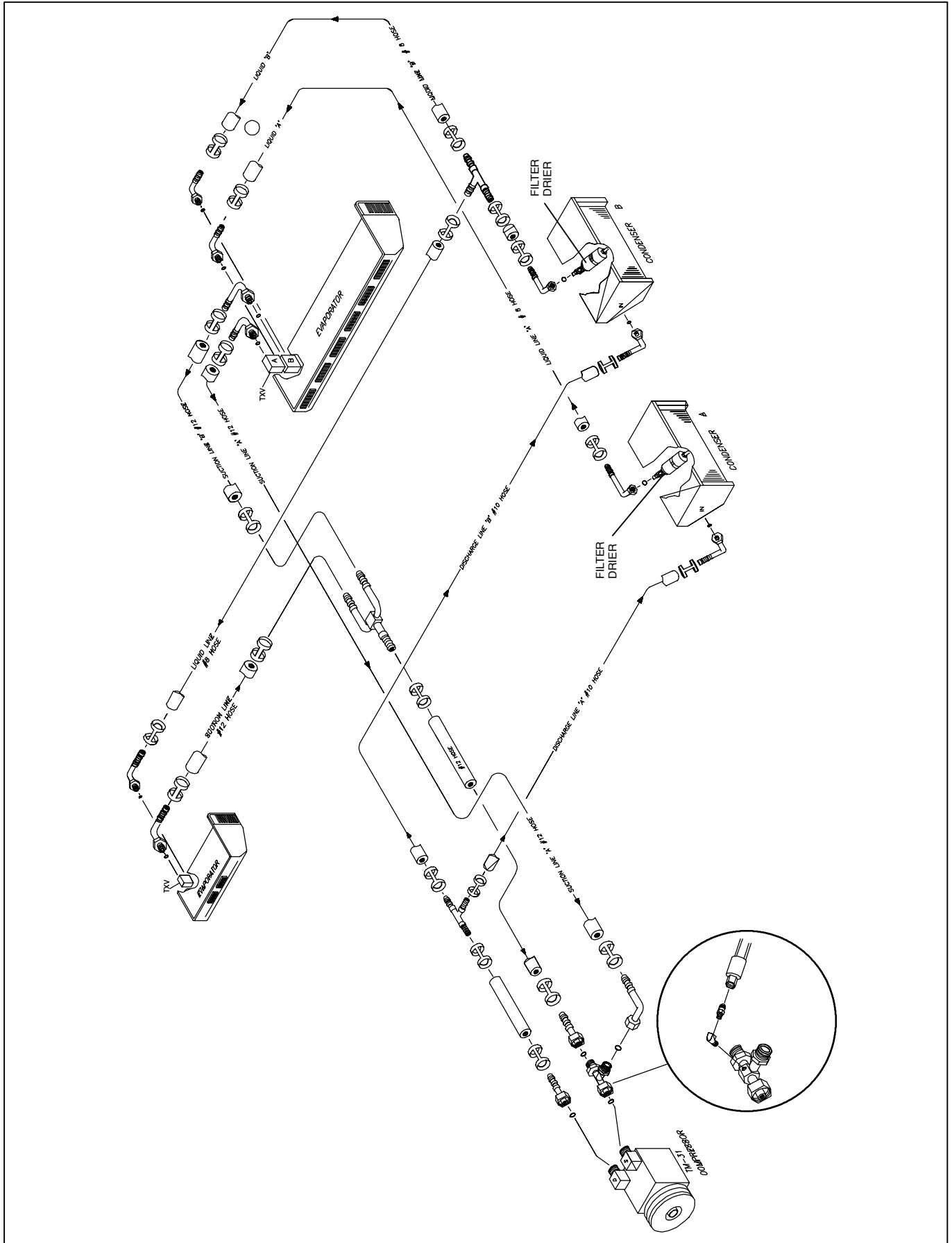

Figure 4-27 (1)EM-3 Evap, (1)EM-7 Evap, (2) Skirt Condensers and a TM-31 Compressor (AC-9632)

## SECTION 5

### ELECTRICAL

#### 5.1 INTRODUCTION

Electrical harness routing is a critical process in the installation of any transportation air conditioning system. Pre-planning of the electrical harness path between components will eliminate encounters with commonly existing conditions which could result in electrical system failure. Following proper electrical harness routing procedures will ensure optimum system performance and provide for a long lasting and trouble free installation.

#### 5.2 SYSTEM WIRING

##### 5.2.1 Electrical Kits

The electrical kits provided with Carrier Transport Air Conditioning systems contain the harnesses/cables and components necessary to safely connect the air conditioning to the vehicle power source and communicate signals between components.

Review the wiring diagram to insure that the kit provided is the proper wiring kit for your air conditioning system.

#### NOTE

Wiring diagrams are not always supplied. Call Carrier Transport Air Conditioning customer service for assistance (1-800-673-2435).

Separate harnesses/cables and route to their appropriate components. Whenever possible route the harness/cable with the corresponding components refrigerant hoses.

##### 5.2.2 Protection

Extreme care must be used when wiring a bus. Plan the routing of the harness prior to installation, being careful to avoid sources of high heat and sharp edges. If the wiring is near any heat source it must be shielded with a heat resistant insulation. When running the harnesses through sheet metal or other sharp parts of the vehicle frame the wires must be protected by grommets or tied off in a manner that prevents chaffing. Where ever possible the harness should be routed with the refrigerant hoses (refer to section 4, Hose Routing). Failure to protect the air conditioning wiring may result in wiring shorts and system malfunctions.

Most electrical components are sensitive to heat and environmental conditions. If at all possible they should be located in a protected area. All exposed electrical terminals (connectors) should be coated with an electrical protectant. Circuit breakers should always be present and located no further than 24 inches (2 feet) from the vehicles power source or battery. Failure to follow these precautions could lead to system failure or in extreme conditions an electrical short-circuit which could cause a fire.

All connections must be tight and secure. When any electrical connection is exposed to the elements it should be coated with an electrical protectant. Ensure a solid electrical ground to the vehicle chassis. Failure to ensure tight, protected connections could cause loss of power to a component resulting in system failure.

##### 5.2.3 Dual Systems

When the bus has a dual compressor system care must be taken to ensure that the electrical system and hose routing are independent for each side. Test and charge one system at a time, thus ensuring each system is functioning properly. Connecting the piping of one system to the electrical signals from another system will result in failures to both systems. It is highly recommended that both ends of the bus harness/cable assemblies be marked for ease of identification.

#### 5.3 VOLTAGES

Carrier Transport Air Conditioning components are designed to operate efficiently at 12.5 or 25 volts. For continued proper operation, all components must have a proper voltage supply, even during low idle. After at least 15 minutes of operation, with all accessories and the air conditioning system(s) on, check the voltage at the evaporator, condenser, and the compressor. Voltages less than 12 volts will cause the condenser and evaporator fans to run slower, resulting in a pressure build-up, excess heat, and compressor failure. Less than 12 volts at the compressor may cause clutch slippage.

Always be sure that the voltages you are working with is compatible with the air conditioning system you are going to install (12 Volt--24 Volt).

#### 5.4 COMPONENT CONNECTIONS

The evaporator, condenser and drivers control panel are pre-wired and are supplied with a short length of harness (pig-tail). Connect the color wires from the appropriate harness/cable to the component (pig-tail) butt connectors (see Figure 5-1).

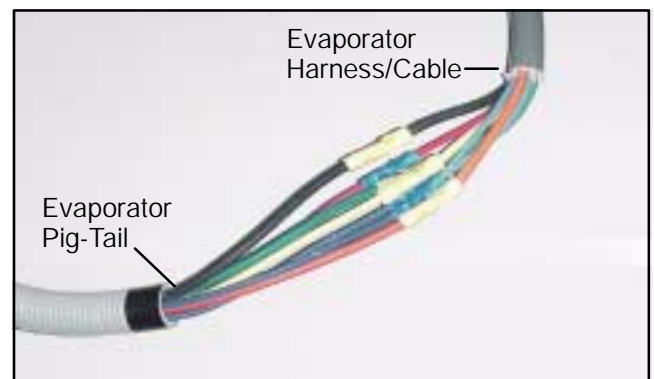

Figure 5-1 Harness & Pig-Tail Connections

##### 5.4.1 Evaporator Chassis Ground, Gen 4 (Excel)

After connecting to the evaporator assembly pig-tail and before routing to the electrical control panel, the evaporator must be grounded to the vehicle chassis as follows:

#### Note

The ground should be as close to the evaporator as possible. Insure that the ring terminal is grounded to bare metal and coated with an electrical protectant.

- a. Carefully make an 8 Inch incision in the evaporator cable close to where you will attach the ground wire terminal.
- b. Locate the green #10 wire from within the harness/cable.
- c. Cut the green #10 wire and pull from the cable.
- d. Strip insulation from wire end and install a 1/4 inch ring terminal.
- e. Remove undercoating or paint from area where ground will be attached.
- f. Securely attach the ground wire terminal with self tapping hardware or bolt (See Figure 5-2 & Figure 5-3).
- g. Close incision in the cable with electrical tape

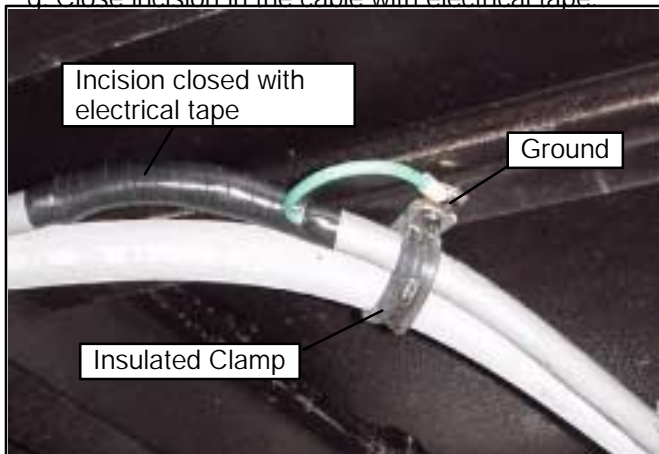

Figure 5-2 Grounded to Clamp

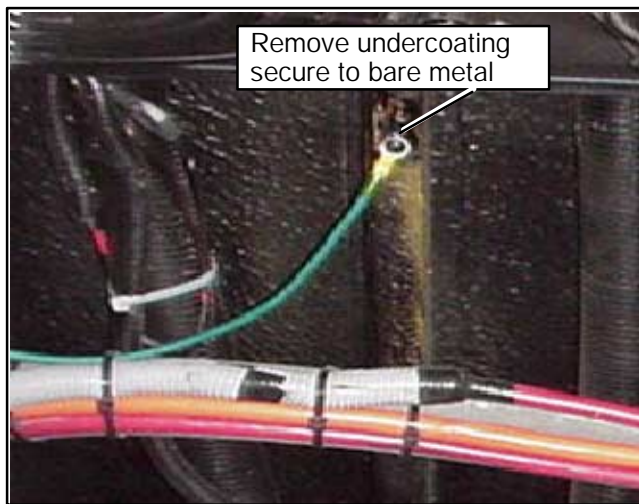

Figure 5-3 Grounded to Chassis Rail

- h. Coat the terminal connection and hardware with an electrical protectant.

Route other ends of harnesses/cables to the electrical control panel, which should be in a protected location. Cut excess harness/cable. Strip harness wires and attach terminal rings. Connect to the appropriate terminal strip number on the electrical control panel (refer to your enclosed system wiring diagram).

## 5.4.2 Evaporator Chassis Ground, Gen 5

Gen 5 evaporators are supplied with a 12 foot section of green, 10 or 6 gauge wire, depending on the evaporator assembly. One end of the green grounding wire will have a #10 ring terminal crimped to it. Securely attach this end to the evaporator assembly top panel. The other end of the wire will have a 1/4 inch ring terminal tie-wrapped to it. Cut the ground wire to desired length, strip off the insulation, and crimp the 1/4 inch ring terminal to the wire. The evaporator must then be grounded to the chassis rail as shown in Figure 5-2/ Figure 5-3 or to the metal frame of the bus roof.

## 5.5 CONTROLS

One of two control systems may be provided. A Manual Control Package or a Total Control Package.

### 5.5.1 Manual controls

If Manual Controls are provided, the controls may be mounted in a panel (Figure 5-4), without the panel (Figure 5-5), or as a dual system (Figure 5-6). The manual controls must be located within easy reach of the driver. The Drivers Controls consists of an evaporator fan speed switch (three speed or variable) and an adjustable thermostat.

#### NOTE

The Ambient Air Sensor (see Figure 5-4) must be located within the vehicle's interior in order to sense the return air temperature.

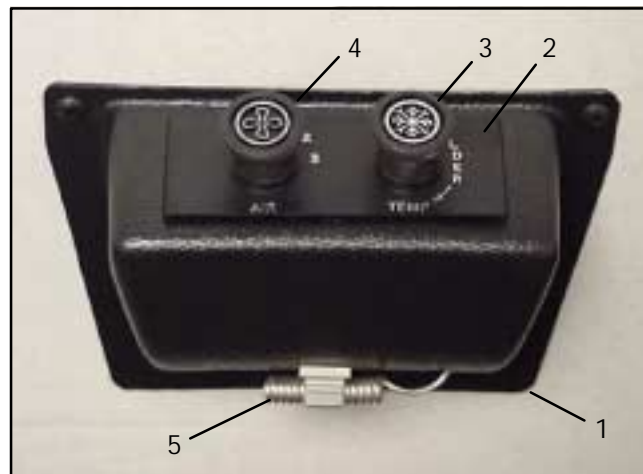

- 1 Control Panel Housing
- 2 Nameplate (Switch Mounting)
- 3 Thermostat Control Switch
- 4 Fan Speed Switch (3 Speed or Variable)
- 5 Ambient Air Sensor (Thermostat)

Figure 5-4 Drivers Control Panel

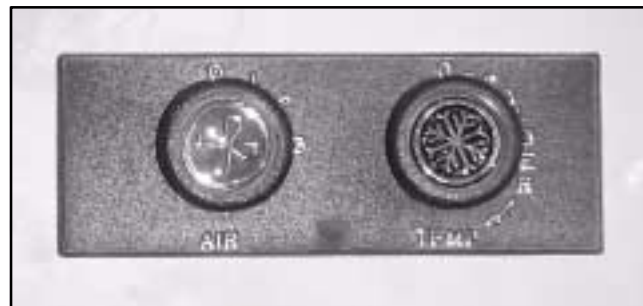

Figure 5-5 Controls Mounted Without Panel

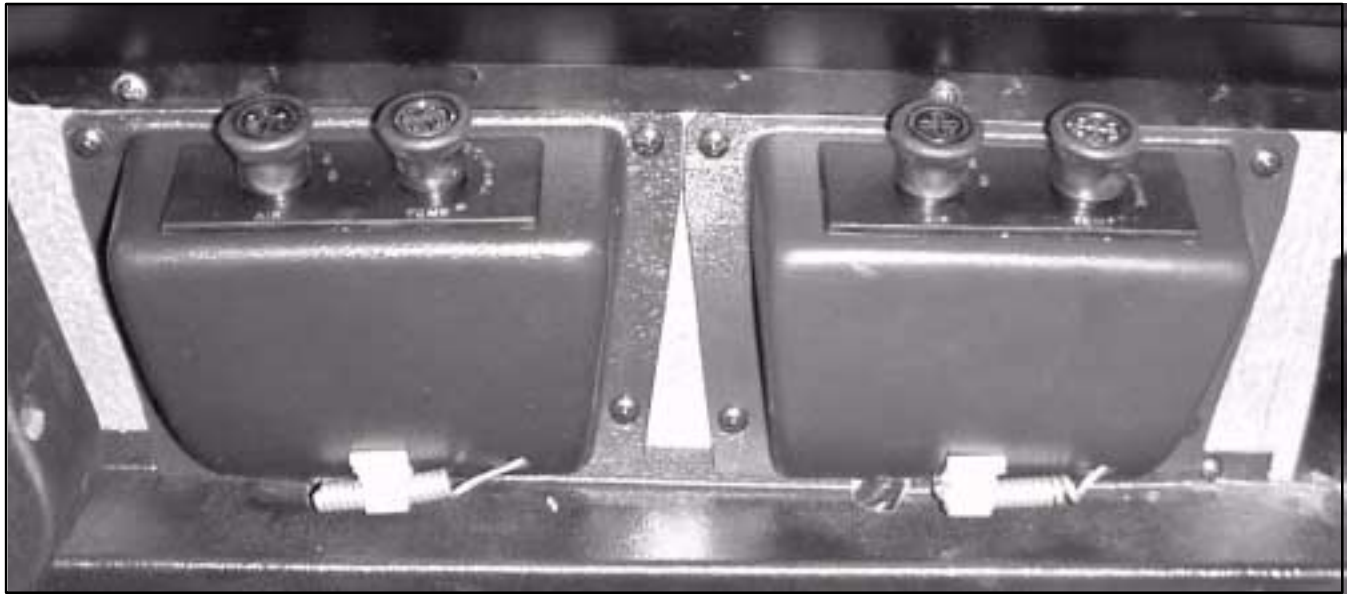
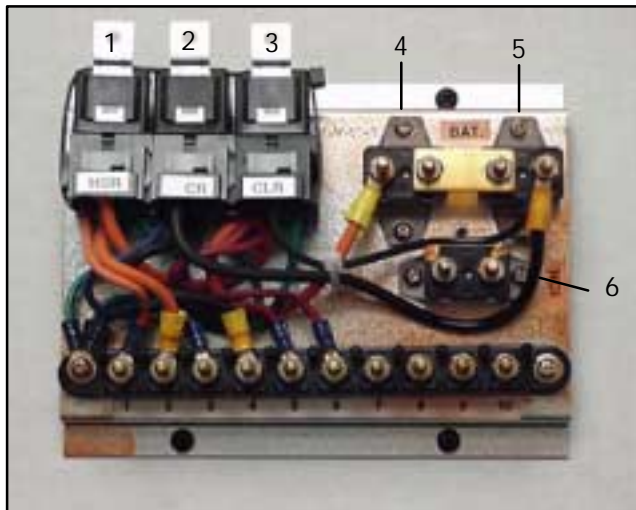

Figure 5-6 Drivers Control Panel (Dual Systems)

### 5.5.2 Electrical Control Panel

The manual controls are wired to the electrical control panel (see Figure 5-7) The panel contains relays and circuit breakers used for system control. It must be located in an area that is protected from heat, moisture, dirt, and road hazards.



1. High Speed Relay
2. Condenser Relay
3. Compressor Clutch Relay
4. Circuit Breaker (HSR)
5. Circuit Breaker (CR)
6. Circuit Breaker (Ignition)

Figure 5-7 Electrical Control Panel (Typical)

## 5.6 TOTAL CONTROL

The Total Control system consists of a Key Pad Display (Figure 5-8), an Electrical Control Panel, (Figure 5-9) and inter connecting wiring. The Key Pad Display must be located within easy reach of the vehicle operator.

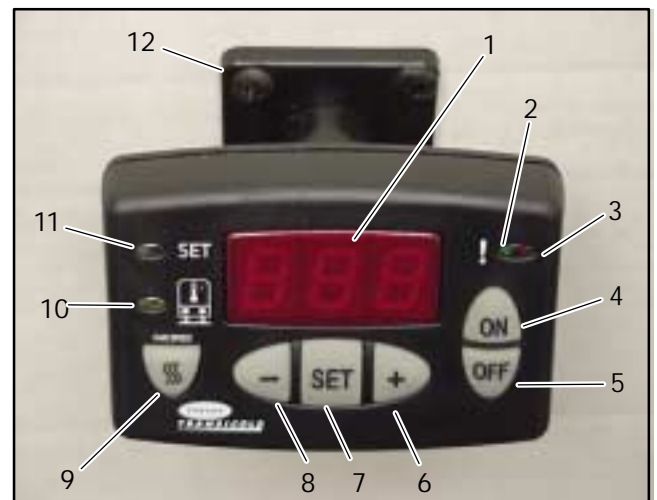

- 1 Display
- 2 Green LED, Cool Mode
- 3 Red LED, Heat Mode  
Red LED, Flash, Alarm
- 4 ON Button
- 5 OFF Button
- 6 Increase Selection
- 7 SET Button
- 8 Decrease Selection
- 9 Fan Speed Button
- 10 Green LED, Inside Temperature
- 11 Green LED, Set Point
- 12 Total Control Mounting Assembly

Figure 5-8 Total Control Key Pad/Display

### 5.6.1 Total Control Electrical Control Panel

The key pad/display is wired to the Total Control electronic control panel (IFigure 5-9). The panel contains relays, circuit breakers, and the microprocessor used for system control. It must be located in an area that is protected from heat, moisture and road hazards.

Care must be taken when routing the return air sensor (thermistor) cable and the cab command cable. Both



these cables can be damaged easily if pulled across rough or sharp areas of the bus chassis or A/C system.

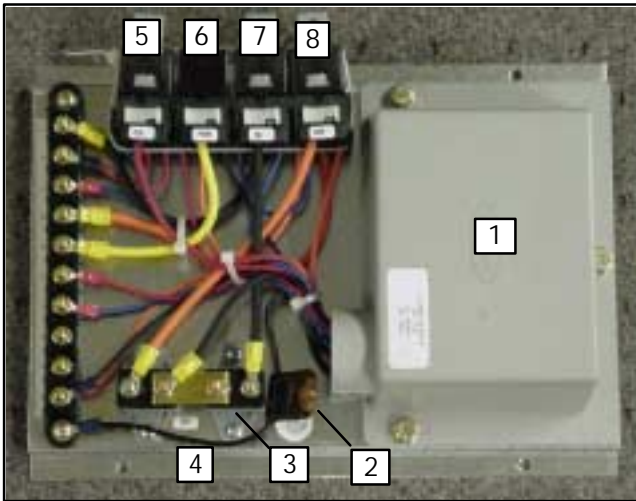

- 1 Logic Module (Speed Control)
- 2 Fuse (5 Amp)
- 3 Circuit Breaker (Condenser)
- 4 Circuit Breaker (High Speed)
- 5 Clutch relay
- 6 Relay Filter - PWM (Pulse Width Modulation)
- 7 Condenser Relay
- 8 High Speed Relay

**NOTE**

A completely wired Gen 5 dual system total control is shown in Figure 5-10. Notice that the system control panels are labeled front and rear. They can also be labeled left or right if side mounted evaporators are used. A easily removable cover was also fabricated for this installation.

Figure 5-9 Total Control Electrical Panel (Typical)



Figure 5-10 Gen 5 Total Control (Dual System)

**5.7 OPERATING INSTRUCTIONS**

Before attempting to operate the system, power must be available from the vehicle battery. If the engine is not

running, start the engine. For complete operating instructions refer to operation and service manual T-299 Split-Systems.

## SECTION 6

### MOUNT KITS AND COMPRESSORS

#### 6.1 INTRODUCTION

Carrier transport Air Conditioning offers a wide range of compressors and corresponding mount kits for most engine-chassis combinations. Carrier Transport Air Conditioning mount kits are engineered to allow precise alignment and belt tensioning adjustments.

The mount and drive kit normally will contain the mounts, hardware, pulleys, belts, idlers, etc. necessary to safely mount the compressor to the bus engine.

Read and follow the installation instructions supplied with each mount kit. Always check the Rev. number on the drawing to determine if there have been any changes to the mount kit since your last installation.

Minor modifications are occasionally necessary and are considered part of the installation process. These mount and drive kits are designed to fit vehicles with standard equipment. The addition of special or optional equipment may interfere with the normal installation.

It is important that the compressor have a solid mount with no stress. The spacing between the compressor mounting ears and the compressor mount may vary slightly due to the manufacturing tolerances. Use shims to close any gap between the compressor ears and mount, *before tightening the compressor mounting bolts*.

Always check pulley and belt alignment and shim as necessary. Failure to align can cause premature wear, belt squeal, and vibration. Use a straight edge to determine proper pulley and belt alignment before securing the mounting hardware (Refer to paragraph 6.3).

Always torque to the specifications noted on each mount kit installation instructions. Refer to Figure 6-2 through Figure 6-3 for torque specifications not noted on the installation drawing.

When a non-permanent or permanent thread-lock is supplied with the mount kit, use where and how specified per the mount kit installation instructions.

Some installations may require a slight modification or rearrangement of the radiator mounting, turbo tubes, fuel lines, reservoirs, water lines, harnesses, or the oil fill tube for proper clearance.

On some applications it may be necessary to install the refrigerant hose and fittings to the auxiliary compressor before mounting and securing.

If system is a "Tie-In" to factory dash air, the refrigerant must be removed with an EPA approved recovery machine. This recovered refrigerant should then be recycled and reused.

#### Note

When the OEM radiator condenser is disconnected (not used), it is recommended by Carrier Transport Air Conditioning that it be removed from the vehicle.

Following established mount and drive installation procedures will ensure proper belt alignment and tensioning, which in turn will promote long belt life and optimum system performance.

#### 6.2 INSTALLATION

Utilize the following procedures when installing a Carrier Transport Air Conditioning mount kit and compressor:

- a. Unpack and inspect components for damage.
- b. Insure the mount kit will fit the engine assembly.
- c. Lay out all brackets, pulleys, hardware, etc. and identify using the enclosed packing list.
- d. If alterations to engine heater hose is necessary, drain coolant. Save coolant for later use.
- e. Disconnect negative battery cable.
- f. Follow the mount kit sequence instructions when installing the weldments, brackets, etc., making sure all bolts are tight, and the correct washers are used.
- g. Use thread-lock whenever noted, and torque bolts to specifications listed on drawing. Refer to Figure 6-2 through Figure 6-3 for torque specifications not noted on the installation drawing.

#### Note

Never substitute the graded hardware that is supplied with the mount kit.

#### Note

Never use an air impact tool to tighten bolts on a mount or compressor. Use a torque wrench.

#### Note

Always use every bracket, support, and stiffener furnished with the kit.

### 6.2.1 TORQUE SPECIFICATIONS

Always torque to the specifications noted on each mount kit installation instructions. The torque values listed in Figure 6-2 and Figure 6-3 are based on the use of lubricated threads.

Bolt Size Dia. mm	Torque (Ft-Lb) Cast Iron Grade 8.8	Torque (Ft-Lb) Cast Iron Grade 10.9	Torque (Ft-Lb) Cast Iron Grade 12.9
6	7	9	9
7	10	13	18
8	18	23	27
10	30	45	50
12	55	75	95
14	85	120	145
16	130	175	210

Figure 6-1 Metric Torque Specs

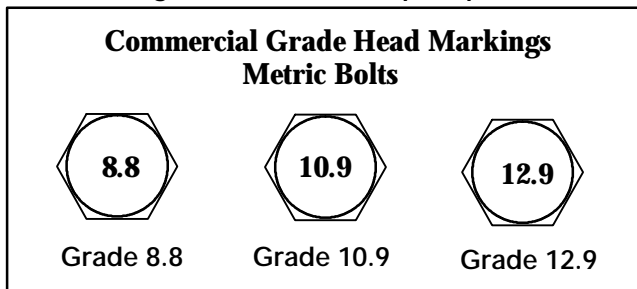

Figure 6-2 Metric Bolt Markings

Bolt Size Dia. mm	Torque (Ft-Lb) Cast Iron Grade 2	Torque (Ft-Lb) Cast Iron Grade 5	Torque (Ft-Lb) Cast Iron Grade 8
1/4-20	5	7	11
5/16-18	10	15	22
3/8-16	18	30	40
7/16-14	30	45	65
7/16-20	32	50	70
1/2-13	45	70	95
1/2-20	50	75	110
5/8-11	82	135	190
5/8-18	93	155	215

Figure 6-3 U.S.S. Torque Specs

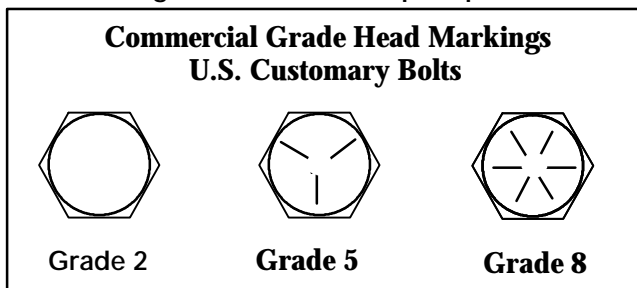

Figure 6-4 U.S.S. Bolt Markings

### 6.3 DRIVE BELT INSTALLATION

#### 6.3.1 Introduction

There are several factors that have major effects on compressor and alternator drive belt(s) life expectancy and reliability. Belt alignment and proper tension being the most critical and controllable by the installer and end-user. Improper alignment and/or tension will cause premature failure of drive belts, driven components as well as a possible safety issue. When improperly installed and/or maintained, drive belts can cause significant damage to equipment as well as service personnel. This document will act as a guideline for proper installation instruction as well as continuous maintenance guidelines which when followed insures years of trouble free service. The following are the biggest factors that effect belt life and system dependability.

- A. Belt Alignment
- B. Belt Tension
  - 1. Over Tensioned
  - 2. Under Tensioned
- C. Belt Clearance
- D. Temperature-Heat
- E. Fluids
- F. Maintenance Procedures

This document acts as a guide only. This document will not replace proper installation training and/or experience required for Carrier A/C Certification. As always, take special caution when working with running engines and drive belts. Safety glasses or goggles must be worn at all times. Loose clothing is also extremely dangerous around moving pulleys and belts.

For questions or concerns not covered here, please feel free to contact the Carrier Transport Air Conditioning Technical Service Hotline at (800) 450-2211.

#### 6.3.2 Belt Clearance

A certain belt clearance needs to be provided for belt span vibration when installing compressors and alternator belts. Figure 6-5 shows the recommended clearance guidelines for preliminary layout work. Due to the large number of variables, actual testing is required to determine whether the clearances are acceptable.

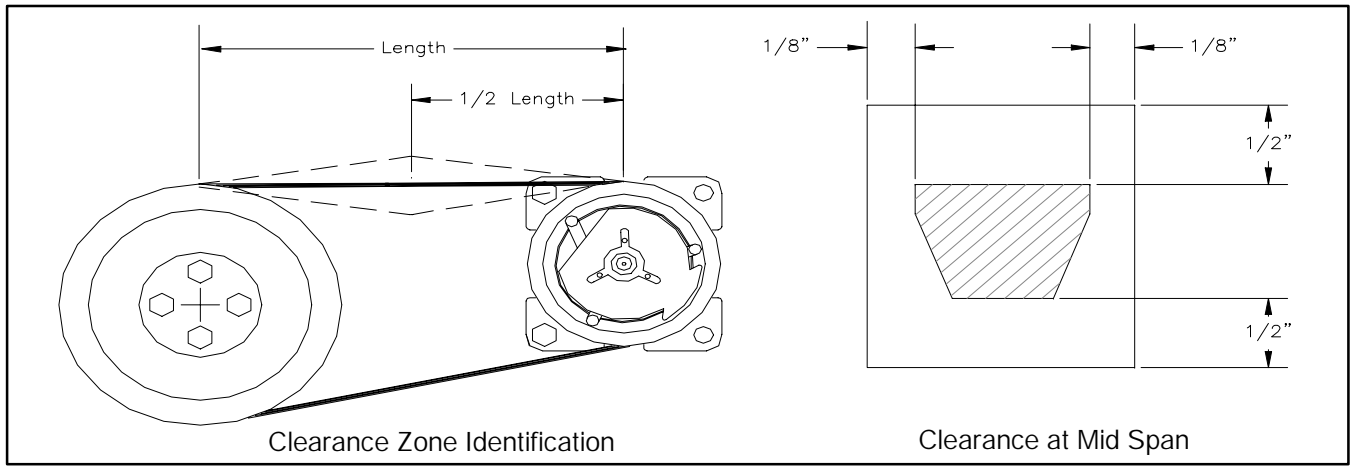

**Figure 6-5 Belt Clearance Requirements**

### 6.3.3 Pulley Alignment

Correct belt alignment is essential for alternator and compressor belt life. The center line of all pulleys related to compressor or alternator drive must be within 1/3 degree of true center. Refer to Figure 6-6 for approximate measurements, and keep in mind, these are maximum values. You should try to attain perfect alignment whenever possible to maximize component and belt life.

Maximum allowable run-out for Poly "V" belts is 1/8 inch.

Maximum allowable run-out for Standard "V" belts is 1/4 inch.

Methods and tools used in determining proper alignment are illustrated in Figure 6-6 and Figure 6-7. A high quality straight edge is a necessity, your eye is not an acceptable method of determining proper belt alignment. Precision Tools make a line of straight edges that would be suitable for compressor and alternator alignment purposes. Other alternatives are available please call Carrier Transport Air Conditioning Technical Hot Line at 1-800-450-2211 with any questions or comments. All mounting brackets should allow for minor belt center line adjustments.

Parallel adjustment is designed into a mount for final alignment during the installation process. This is necessary due to manufacturing and engine tolerances as well as multiple applications and different engine options available. Parallel misalignment is corrected by moving the driven pulley (alternator or compressor) into alignment with the drive pulley. This can be done using several methods. Spacing the component forward or rearward by adding or removing spacers is the most popular method used to achieve proper alignment. Other methods such as sliding the component forward or rearwards using slide plates and/or slots in the main weldment are also used.

Angular misalignment is often caused by tolerances in several pieces, such as hardware to mounting holes and plates to components. This could also be from a poorly built design and/or installed bracket. Excessive modifications such as grinding or drilling holes to a larger diameter to apply/install a kit should be avoided when possible. Minimizing tolerances must be considered during the design process to minimize this problem. Angular misalignment is corrected by loosening the mounting hardware, adjusting the compressor to the proper angle and retightening the mounting hardware.

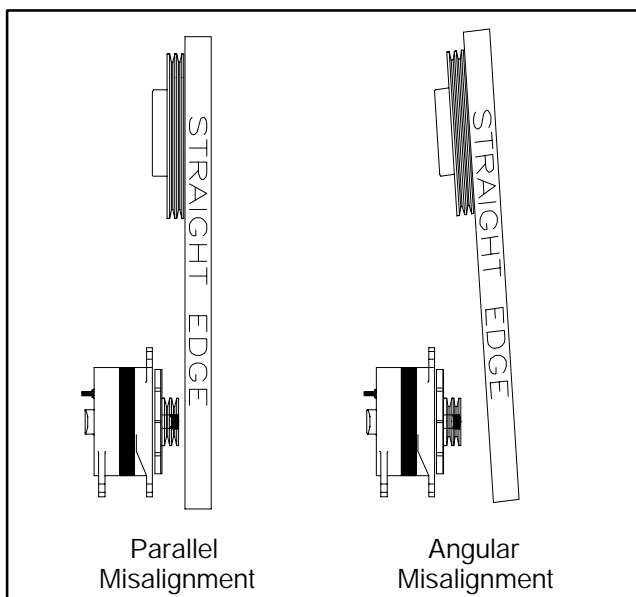

**Figure 6-6 Belt Misalignment**

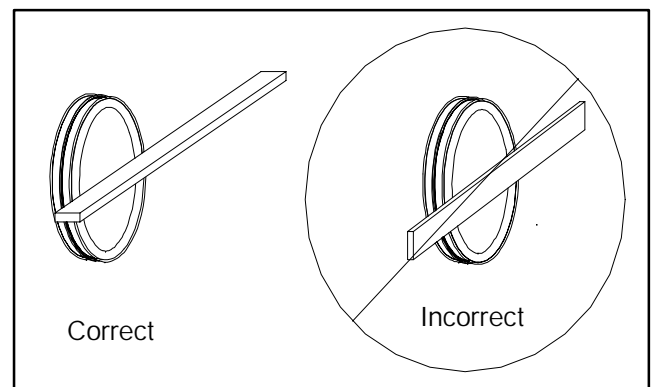

**Figure 6-7 Straight-Edge Application**

Proper use of a straight edge is illustrated in Figure 6-7. Never use a straight edge on the wide/flat side, as they are not accurate. The thin edge is a straight surface and the only accurate surface. The straight edge must be flush across the face of the pulley. Then, to measure the alignment, lower the other end down to the driven pulley(s). Adjustments are made based on results of the aforementioned. Note that the pulley rim width must be

considered when making the aforementioned measurements.

The next step is to lay the straight edge flush across the face of the driven pulley. This is the best way to determine angular misalignment. Again, adjust as required. You should repeat this step for all pulleys until acceptable alignment is achieved. Note the drive pulley is the primary guide for alignment. Do not use idlers as a guide for proper component belt alignment as bearing play could give you false readings.

### 6.3.4 Drive Belt Tension-Guidelines

Proper belt tension is essential for not only belt life, but also the alternator and compressor life as well. Heat is a major enemy of compressors and alternators that can cause unnecessary stress and greatly reduce component life.

Listed in Figure 6-8 are the examples specific to belt tension concerns:

- A. Under tension would promote belt slippage causing excessive heat. Heat equals premature alternator and/or compressor failure.
- B. Over tension could cause premature bearing failure and excessive wear on drive and driven components.

Proper belt tension is obtained by referring to Figure 6-8 . Find the belt used and where applied (compressor or alternator drive, Single "V" or Poly "V" 4-8 ribs).

Notice that new belt tension is higher than in-service or re-tension amount. All new belts require a run-in period. During this period, a new belt will stretch more in a 10 hour run time than the entire life of the belt. So it is important to recheck belt tension after run-in or re-tension new belts if less than re-tension amount prescribed above. You should check belt tension with the belt "hot." However, the belt must be allowed to cool before re-tensioning. Drives which incorporate automatic tensioners do not require a run-in period or re-tensioning.

### 6.3.5 Measuring Methods for Belt Tension

There are several methods and tools available for determining belt tension. The industry's acceptable method would be to use a belt tension gauge as manufactured by Kent-Moore or approved equal (CTD Part Numbers 07-00203-00 for non-cogged V-belts & 07-00253-00 for Poly-V's). There are also several other models available than can be used. Please follow manufacturer guidelines regarding gauge selection operation and calibration requirements. You must get the correct tension gauge for your specific belt type(s).

Drive	Belt Top Width	New Belt Lbs. Tension	Re-Tension Lbs. Tension	Re-Tension Threshold
Alternator	All	110	90	70
Compressor	All	130	105	80
Poly-Rib Belt & Serpentine Drive	6 or More Ribs	145	105	90

Figure 6-8 Belt Tension Guide

## 6.4 COMPRESSOR INSTALLATION

### 6.4.1 Installation Position

The compressor should be installed on the vehicle within the range shown in Figure 6-9. If installed outside the range shown in Figure 6-9 the compressor will be adversely affected. Most split system compressors are equipped with a pressure feed lubrication system which cannot function properly if the compressor is installed outside this range. As a precaution, it is recommended that once the compressor is mounted in its proper and final position, the compressor clutch is turned over by hand at least 10 revolutions before installation of the drive belt up to the pulley. If this is not done before the compressor is put into service, damage to the compressor valves can result from oil slugging. This is not covered under warranty.

### 6.4.2 Installation Precautions

The new compressor is (should be) filled with the specific quantity of compressor oil and nitrogen gas. When mounting the compressor on the vehicle, take the following steps:

- a. Loosen the discharge side connector's cap and gently release the nitrogen from compressor. Take care not to let oil escape.
- b. Slowly rotate the compressor's magnetic clutch several times by hand to distribute the oil which has settled in the cylinders.
- c. When replacing the compressor on a system, the compressor should be installed after adjusting the amount of oil. (Refer to T-299 Operation and service - Split Systems) When installing the compressor on a new system, be sure to follow factory guidelines.

### 6.4.3 Mounting Compressors

Clearance between the compressor mounting supports (ears) and its bracket must be less than 0.004 inches (0.10mm). Use shims as necessary to adjust this clearance. This will reduce the stress on the compressor which can cause components to fail. Be sure to maintain proper pulley alignment for the drive belt.

It is important that the compressor be mounted properly when installed (See Figure 6-9). The side to side mounting angle of the compressor must remain  $\pm 45^\circ$  from the horizontal. The forward to backward angle must be within  $\pm 10^\circ$  of horizontal.

### Note

The side to side mounting angle of the A-6 compressor must remain  $\pm 15^\circ$  from the horizontal (See Figure 6-9).

Access to the air conditioning service ports will vary. If access cannot be made at the compressor, in-line service ports must be installed as close to the compressor as possible.

Special care must be used when routing the suction and discharge hoses through the engine compartment. These hoses must be kept away from sharp objects and hot areas of the engine. Damage to the refrigerant hoses and leaks may occur. The hot areas can also reduce capacity by adding heat into the refrigerant inside the hoses. This added heat must then be rejected by the condensing coil. Since each coil has a limited ability to reject heat, that kind of extra heat simply means less cooling inside the bus where it is needed.

### 6.4.4 Oil Charge

Each compressor comes with a standard charge of oil inside. This quantity of oil is enough to supply the compressor lubrication when installed into an already "oil wet" system. New systems require an extra quantity of oil be added to "wet" all interior surfaces of the system. Refer to Section 8, Charging Procedures, for the approximate refrigerant and oil amounts.

### CAUTION

**Verify that the oil added to the air conditioning system is the same oil that is in the compressor. The mixing of incompatible oils will damage your system.**

Refer to Section 7 for evacuation, Section 9 for leak checking, and Section 8 for charging procedures. Refer to Section 4 for hose routing.

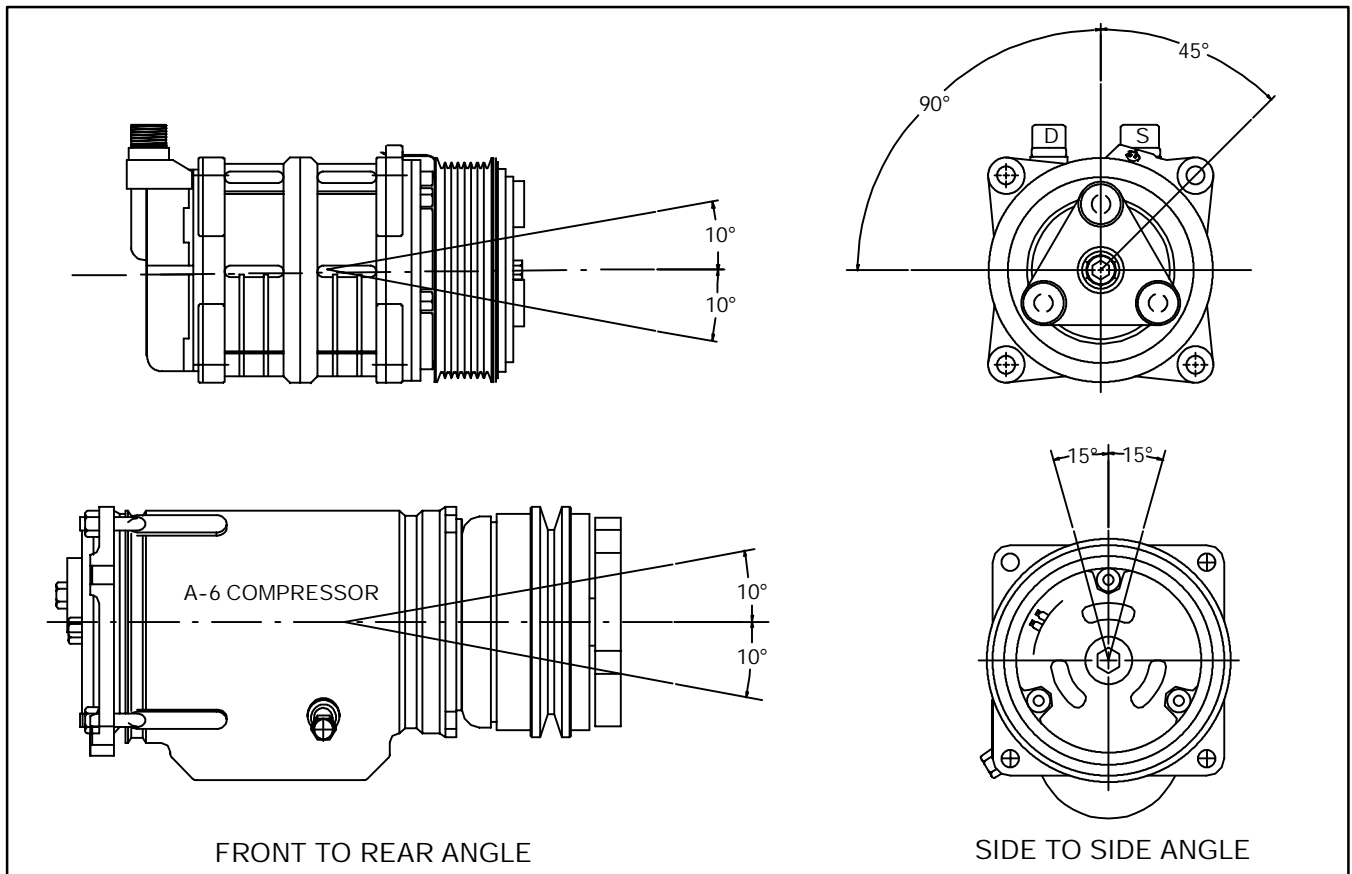

Figure 6-9 Compressor Mounting Angles

## SECTION 7

### EVACUATION

#### 7.1 INTRODUCTION

The process of evacuation is an important step in the servicing and maintenance of any air conditioning system. The purpose of evacuation is to remove all air and moisture from the system in preparation for adding refrigerant and oil during the charging process. It is imperative that all air and moisture be removed from the system, as their presence is detrimental and will negatively affect performance and longevity of the systems components. Air remaining in the air conditioning system will degrade the systems cooling performance, while any moisture remaining in the system is both non-condensable and a basis for acid formation. Moisture is the deadly enemy of refrigeration systems.

#### 7.2 REFRIGERANT SERVICE TOOLS

The following equipment is essential when performing an installation of or servicing of any Carrier Transport Air Conditioning system. Refer to Figure 7-2 for service component connections.

- 1 **Manifold Gauge Set** - Provides access to and monitors pressures within the system. Manifold Gauge Sets are available in different configurations and styles. 3-way or 4-way, Liquid filled, with or without a sight glass, 3 hoses or 4 hoses, 1/4 inch or 3/8 inch manifold connections, etc. All are acceptable for servicing a Carrier Transport Air Conditioning system. Familiarize yourself with the proper operation of your Manifold Gauge Set before attempting any service.
- 2 **R134a Low Side (Suction) Coupler** - Connects the air conditioning system Suction Access Port to the Manifold Gauge Set.
- 3 **R134a High Side (Discharge) Coupler** - Connects the air conditioning system Discharge Access Port to the Manifold Gauge Set.
- 4 **Vacuum Pump - 2 Stage (5 CFM Minimum)** - Removes moisture and air from the air conditioning system in order to obtain required micron level.
- 5 **Micron Gauge** - Monitors the evacuation process in units of microns. Micron gauges can be either digital (electronic) or analog. When the Micron Gauge is used as specified by the manufacturer you can be assured all contaminants have been removed from the air conditioning system. Proper use of the Micron Gauge will also serve as a first indication of a leak tight system.
- 6 **Recovery/Recycle Machine (R134a)** - Recovers and Recycles R134a refrigerant that is present within the air conditioning system.
- 7 **Refrigerant Scale** - Accurately weighs the transfer of refrigerant into the air conditioning system.
- 8 **Refrigerant Cylinder** - Storage tank for R134a.
- 9 **Heat Blanket** - Used to increase internal temperature of the refrigerant cylinder, greatly increasing the transfer of refrigerant to the air conditioning system.
- 10 **Oil Injector** - Used to add additional amounts of oil to a closed system.

11 **Vacuum Pump** - Air and moisture are removed from the system by inducing a vacuum through the use of a vacuum pump. Carrier Transport Air Conditioning recommends a 5 CFM or larger vacuum pump for optimum evacuation in the shortest time. A vacuum, which is measured in microns, results when pressure is reduced within the system. Functionally, reducing the pressure results in reducing the boiling point of water (moisture) that may be in the system. Through the process of vaporization, the water (moisture) changes state from a liquid to a vapor and is drawn off by the vacuum pump and removed from the system. If properly completed, the system is now ready for charging.

#### NOTE

Using a compound gauge (Low Side Gauge) for determination of vacuum level is not recommended because of its inherent inaccuracy. A micron gauge must always be used to insure a proper evacuation.

#### 7.2.1 Preparation

- a. Evacuate and dehydrate only after pressure leak test. (Refer to paragraph 9.2.)
- b. Essential tools to properly evacuate and dehydrate any system include a vacuum pump (5 cfm=8 m<sup>3</sup>/hr volume displacement) and an electronic vacuum (micron) gauge. (The pump is available from Carrier Transicold, P/N 07-00176-11.)
- c. If possible, keep the ambient temperature above 60\_F (15.6\_C) to speed evaporation of moisture. If the ambient temperature is lower than 60\_F (15.6\_C), ice might form before moisture removal is complete. Heat lamps or alternate sources of heat may be used to raise the system temperature.

#### 7.2.2 Procedure - Complete system

- a. Remove all refrigerant using an approved refrigerant recovery system, following manufacturers recommendations.
- b. The recommended method to evacuate and dehydrate the system is to connect two evacuation hoses (see Figure 7-2) to the vacuum pump and refrigeration system. Be sure the service hoses are suited for evacuation purposes.
- c. Test the evacuation setup for leaks by drawing a deep vacuum through the manifold gauge set, hoses, and service couplers with the vacuum pump. Shut off the pump and check to see if the vacuum holds. Repair leaks if necessary.
- d. Open the vacuum pump and electronic vacuum (micron) gauge valves, if they are not already open. Start the vacuum pump. Evacuate unit until the electronic vacuum gauge indicates 2000 microns. Close the electronic vacuum gauge and vacuum pump valves. Shut off the vacuum pump. Wait a few minutes to be sure the vacuum holds.
- e. Break the vacuum with clean dry refrigerant 134a gas. Raise system pressure to approximately 2 psig (0.2 kg/cm<sup>2</sup>), monitoring it with the compound gauge.
- f. Remove refrigerant using a refrigerant recovery system.

- g. Repeat steps d. and e. one time.
- h. Evacuate unit to 500 microns. Close the electronic vacuum gauge and vacuum pump valves. Shut off the vacuum pump. Wait five minutes to see if vacuum holds. This procedure checks for residual moisture and/or leaks.
- i. With a vacuum still in the unit, the refrigerant charge may be drawn into the system, the refrigerant charge may be drawn into the system from a refrigerant container on weight scales.

### 7.3 INSTALLING MANIFOLD GAUGES

The manifold gauge set is used to determine system operating pressures, add refrigerant charge, and to equalize or evacuate the system.

When the suction pressure hand valve is frontseated (turned all the way in), the suction (low) pressure can be checked. When the discharge pressure hand valve is frontseated, the discharge (high) pressure can be checked. When both valves are open (turned counter-clockwise all the way out), high pressure vapor will flow into the low side. When the suction pressure valve is open and the discharge pressure valve shut, the system can be charged. Oil can also be added to the system.

A R-134a manifold gauge/hose set with self-sealing hoses is required for service of the models covered within this manual. The manifold gauge/hose set is available from Carrier Transicold. (Carrier Transicold P/N 07-00294-00, which includes items 1 through 6. To perform service using the manifold gauge/hose set, do the following:

#### a. Preparing Manifold Gauge/Hose Set For Use

1. If the manifold gauge/hose set is new or was exposed to the atmosphere it will need to be evacuated to remove contaminants and air as follows:
2. Back seat (turn counterclockwise) both field service couplings (see Figure 7-1) and midseat both hand valves.
3. Connect the yellow hose to a vacuum pump.
4. Evacuate to 10 inches of vacuum.
5. Connect yellow line to R134a cylinder, purge line, then charge with to a slightly positive pressure of 0.1 kg/cm<sup>2</sup> (1.0 psig).
6. Front seat both manifold gauge set valves and disconnect from cylinder. The gauge set is now ready for use.

#### b. Connecting Manifold Gauge/Hose Set

Connection of the manifold gauge/hose set (see Figure 7-2) is dependent on the type system being serviced. The center hose connection is brought to the tool being used. To connect the manifold gauge/hose set, do the following.

1. Connect the high side field service coupling to the discharge line service valve port.

2. Turn the high side field service coupling knob (red) clockwise, which will open the high side of the system to the gauge set.
3. Connect the low side field service coupling to the suction service valve port.
4. Turn the low side field service coupling knob (blue) clockwise, which will open the low side of the system to the gauge set.

#### CAUTION

To prevent trapping liquid refrigerant in the manifold gauge set be sure set is brought to suction pressure before disconnecting.

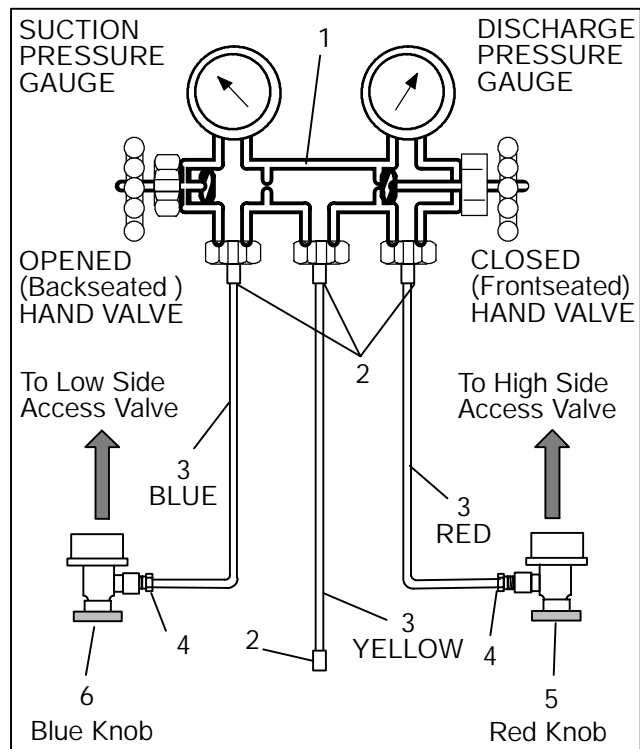

1. Manifold Gauge Set
2. Hose Fitting (0.5-16 Acme)
3. Refrigeration and/or Evacuation Hose (SAE J2196/R-134a)
4. Hose Fitting w/O-ring (M14 x 1.5)
5. High Side Field Service Coupling
6. Low Side Field Service Coupling

Figure 7-1 Manifold Gauge Set

#### c. Removing the Manifold Gauge Set

1. Midseat both hand valves on the manifold gauge set and allow the pressure in the manifold gauge set to be drawn down to suction pressure. This returns any liquid that may be in the high side hose to the system.
2. Backseat both field service couplings and frontseat both manifold set valves. Remove the couplings from the service ports.
3. Install both service port caps (finger-tight only).



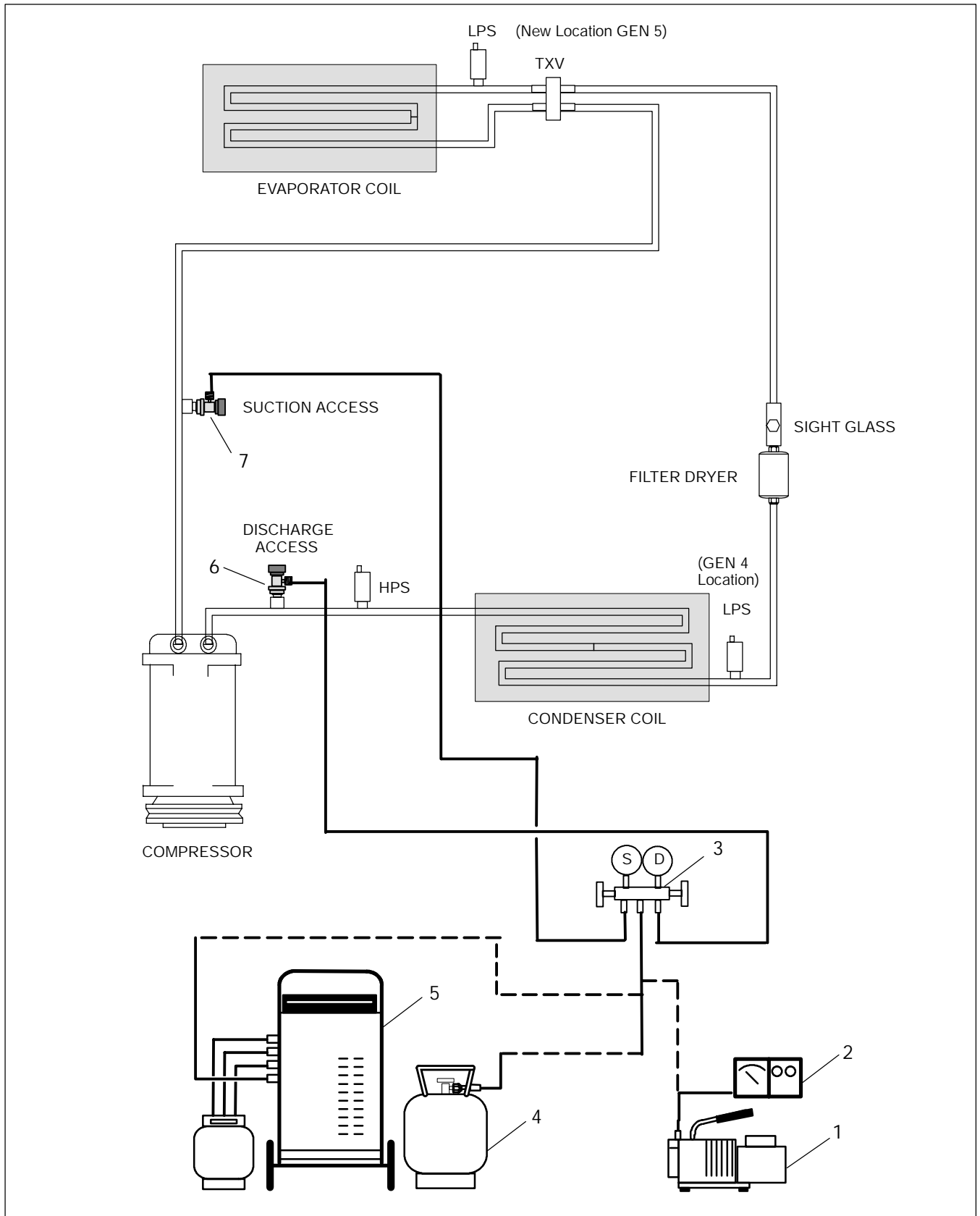

- |    |                      |    |                                     |
|----|----------------------|----|-------------------------------------|
| 1. | Vacuum Pump          | 5. | Recovery/Recycle Machine            |
| 2. | Micron Gauge         | 6. | R134a High (Discharge) Side Coupler |
| 3. | Manifold Gauge Set   | 7. | R134a Low (Suction) Side Coupler    |
| 4. | Refrigerant Cylinder |    |                                     |

**Figure 7-2 Refrigerant Service Connections (Split Systems)**

## SECTION 8

### CHARGING PROCEDURES

#### 8.1 INTRODUCTION

Charging is the process of calculating and then introducing the correct amounts of refrigerant and oil into the air conditioning system. Accurate charge levels will result in optimum system performance and insure the longevity of the system components.

##### 8.1.1 . Proper R134a Charge

A system overcharged with refrigerant operates under high head pressure which can damage components. A system undercharged with refrigerant will result in poor system performance.

#### NOTE

An overcharged or undercharged system may contribute to system compressor failure.

Calculations for determining the proper refrigerant charge are based on component capabilities and liquid line lengths as indicated on Carrier Transport Air Conditioning charging tables. Refer to Table 8-1 or Table 8-2 for the approximate refrigerant charge. Refer to Table 8-4 to determine the exact refrigerant charge.

##### 8.1.2 . Proper Oil Charge

Accurate charge levels of oil with the refrigerant are also critical to proper performance and component longevity. A system undercharged with oil will result in reduced compressor life due to lack of lubrication. A system overcharged with oil will experience poor system performance due to reduced thermal transfer capabilities. Refer to Table 8-1 or Table 8-2 for the approximate oil amounts. Refer to Table 8-3 for the correct compressor oil type.

##### 8.1.3 . Liquid Charging

The practice of charging liquid refrigerant into the suction side with the compressor running will damage or destroy the compressor, as the liquid is not compressible.

##### 8.1.4 . PAG And POE Oils

It is very important to use the lubricant type specified by the compressor manufacturer. (Refer to Table 8-3). Using oil other than the specified oil can result in reduced performance and a reduction in compressor life.

#### NOTE

Using oil other than that specified in Table 8-3 will void the compressor warranty.

**Table 8-1 SPLIT SYSTEM REFRIGERANT AND OIL CHARGING TABLE (THROUGH GEN 4)**

Evaporator Up to GEN 5	Condenser All Series	Recommended R134a Charge	Recommended Oil Charge*
EM-1, EM-2, or EM-9	CM-2	5.00 Pounds	10.0 Ounces
EM-1, EM-2, or EM-9	CM-11	5.25 Pounds	10.5 Ounces
EM-6	CM-2	4.00 Pounds	8.0 Ounces
EM-6	CM-11	4.25 Pounds	8.5 Ounces
EM-1, EM-2, or EM-9	CM-3	5.50 Pounds	11.0 Ounces
EM-1, EM-2, or EM-9	CM-7	6.50 Pounds	13.0 Ounces
EM-3	(2) CM-2	4.25 Pounds Each	8.5 Ounces Each
EM-3	(2) CM-7	6.25 Pounds Each	12.5 Ounces Each
EM-3	(2) CM-3	5.50 Pounds Each	11.0 Ounces Each
EM-3	(2) CM-7	6.25 Pounds Each	12.5 Ounces Each
EM-14	CM-2	3.50 Pounds	7.0 Ounces
EM-14	CM-11	3.75 Pounds	7.5 Ounces
EM-17	CM-5	19.0 Pounds	Consult Factory
EM-17	KR-4	13.0 Pounds	Consult Factory
EM-17 Split System	(2) CM-3	6.00 Pounds Each	12.0 Ounces Each

**Table 8-2 SPLIT SYSTEM REFRIGERANT AND OIL CHARGING TABLE (GEN 5)**

Evaporator GEN 5	Condenser All Series	Recommended R134a Charge	Recommended Oil Charge*
GEN 5 - EM-1	CM-2 or CM-4	4.75 Pounds	9.5 Ounces
GEN 5 - EM-1	CM-11	5.00 Pounds	10.0 Ounces
GEN 5 - EM-1	CM-3	5.25 Pounds	10.5 Ounces
GEN 5 - EM-1	CM-7	6.25 Pounds	12.5 Ounces
GEN 5 - EM-7	CM-2 or CM-4	4.00 Pounds	8.0 Ounces
GEN 5 - EM-7	CM-11	4.25 Pounds	8.5 Ounces
GEN 5 - EM-2	CM-2 or CM-4	4.50 Pounds	9.0 Ounces
GEN 5 - EM-2	CM-11	4.75 Pounds	9.5 Ounces
GEN 5 - EM-2	CM-3	5.00 Pounds	10.0 Ounces
GEN 5 - EM-2	CM-7	6.00 Pounds	12.0 Ounces

The data listed in Table 8-1 and Table 8-2 is based on a 20 foot liquid line. Increase the charge by 0.5 pound for each additional 10 feet of liquid line.

**8.1.5 . Evaporator Tie-In**

When an after market in-dash evaporator is added to a standard system the refrigerant charge will increase by approximately 1 pound.

If attempting to use a CM-2 condenser with a tie-in call Carrier Transport Air conditioning technical support for an application review.

**Table 8-3 COMP. OIL TYPE & PART NUMBERS**

Manufacturer	Oil Type	Part Number
Tama/Zexel/Ice	PAG	07-00336-00
Sanden	PAG	07-00335-00
General Motors	PAG	46-50003-00
Dodge	PAG	07-00332-00
Ford	PAG	07-00334-00
Climate Control	POE	07-00317-00

For questions regarding charging procedures, call Carrier Transport Air Conditioning technical support at 1-800- 450-2211.

**8.1.6 . Adding Refrigerant to System (Full Charge)**

- a. Evacuate unit and leave in deep vacuum.
- b. Place cylinder of R-134a on scale and connect charging line from cylinder to liquid line valve. Purge charging line at liquid line valve and then note weight of cylinder and refrigerant.
- c. Calculate the approximate refrigerant charge using either Table 8-1 or Table 8-2. Open liquid valve on refrigerant cylinder. Open suction line service port coupler and allow the liquid refrigerant to flow into the unit until the correct weight of refrigerant has been added as indicated by scales.

**NOTE**

It may be necessary to finish charging unit through suction service port in gas form, due to pressure rise in high side of the system.

- d. Close suction line service port coupler. Close liquid valve on cylinder.
- e. Start unit in cooling mode. Run approximately 10 minutes and check the refrigerant charge. (Refer to Table 8-4).

**Table 8-4 CARRIER TRANSPORT AIR CONDITIONING SYSTEM PERFORMANCE CHART**

Determine the approximate refrigerant charge using Table 8-1 or Table 8-2 .

Follow the procedures listed below to determine if the correct charge has been obtained.

Table			Procedure	Your Entry	Example
Pres- sure	Refrigerant Temp.				
PSIG	R-12	R134a	1. Connect Manifold Gauge Set To Air Conditioning System Certified Air Conditioning Mechanic Only	NONE	NONE
(A)	(B)	(C)			
95	87	85	2. Measure outside (ambient) air temperature. Enter here ----- -->	_____ Degrees F	100 Degrees F
100	90	88			
105	93	90			
110	96	93			
115	99	96			
120	102	98	3. Add 40 degrees F to the outside (ambient) air temperature ---->	40 Degrees F _____ Degrees F	40 Degrees F 140 Degrees F
125	104	100			
130	107	103			
135	109	105			
140	112	107			
145	114	109	4. Find closest refrigerant temperature in Table (B or C) and enter here --- -->	_____ Degrees F	139 Degrees F
150	117	112			
155	119	114			
160	121	116			
165	123	118			
170	126	120	5. Going across the Table, find the corresponding pressure (A) -->	(D)=_____ PSI	225 PSI
175	128	122			
180	130	123			
185	132	125			
190	134	127			
195	136	129	6. If the Discharge Pressure (High Side) on gaugers (With compressor engaged, engine speed 1200 RPM, and system operating) is :  Greater than (D) - Reduce refrigerant by 4 ounce increments.  Less than (D) - Add refrigerant  Wait 10 minutes for system to stabilize before taking new readings	***	***
200	138	131			
205	140	132			
210	142	134			
215	143	136			
220	145	137			
225	147	139			
235	150	142			
245	154	145			
255	157	148			
265	160	151			
275	163	153			

## SECTION 9

### LEAK CHECKING

#### 9.1 INTRODUCTION

The purpose of leak checking is to verify the integrity of the hose/fitting connections and components. A refrigerant leak check should always be performed after installing a new system or the system has been opened to replace or repair a component. It is imperative that the inspection for refrigerant leaks be conducted in a thorough and meticulous manner. Even the smallest leak can result in poor system performance and premature compressor failure. When a leak occurs, the refrigerant is replaced by air and moisture from outside the system. Without a complete charge of refrigerant in the system, insufficient oil is returned to the compressor. The compressor will overheat and eventually fail. Following established leak checking procedures will result in long term performance and assure longevity of the system components.

##### 9.1.1 Micron (Vacuum) Gauge

Carrier Transport Air Conditioning recommends a Micron (Vacuum) Gauge to assure that the proper vacuum level is attained. When isolated according to instructions the Micron Gauge will show a loss of evacuation vacuum, making it an excellent first leak check.

##### 9.1.2 Nitrogen

A common method in use for leak detection, is pressurizing the system with dry nitrogen and checking with a soap bubble solution at suspected leak sites. While this method will find large leaks, it is limited in detection of the smaller leaks found with R134a.

#### WARNING

**DO NOT USE A NITROGEN CYLINDER WITHOUT A PRESSURE REGULATOR**

#### NOTE

If the system is to be pressurized with refrigerant gas it must be emphasized that only the correct refrigerant cylinder be connected to pressurize the system. Any other gas or vapor will contaminate the system, which will require additional evacuations (Refer to Figure 9-1 for service connections).

#### 9.2 REFRIGERANT LEAK CHECKING

#### WARNING

**Never use air for leak testing. It has been determined that pressurized, air-rich mixtures of refrigerants and air can undergo combustion when exposed to an ignition source.**

- a. Charge the system with refrigerant 134a to build up pressure between 30 to 50 psig.
- b. Add sufficient nitrogen to raise system pressure to 150/200 psig. (10.21/13.61 bar).

#### Note

Larger split systems may be equipped with service valves and a liquid line solenoid. Ensure these service valves are open and power the liquid line service valve from an external source.

- c. The recommended procedure for finding leaks in a system is with a R-134a electronic leak detector (CTD Part Number 07-00295-00). Testing joints with soap-suds is satisfactory only for locating large leaks.
- d. Remove refrigerant using a refrigerant recovery system and repair any leaks.
- e. Evacuate and dehydrate the unit (Refer to Section 7).
- f. Charge the unit. (Refer to Section 8).

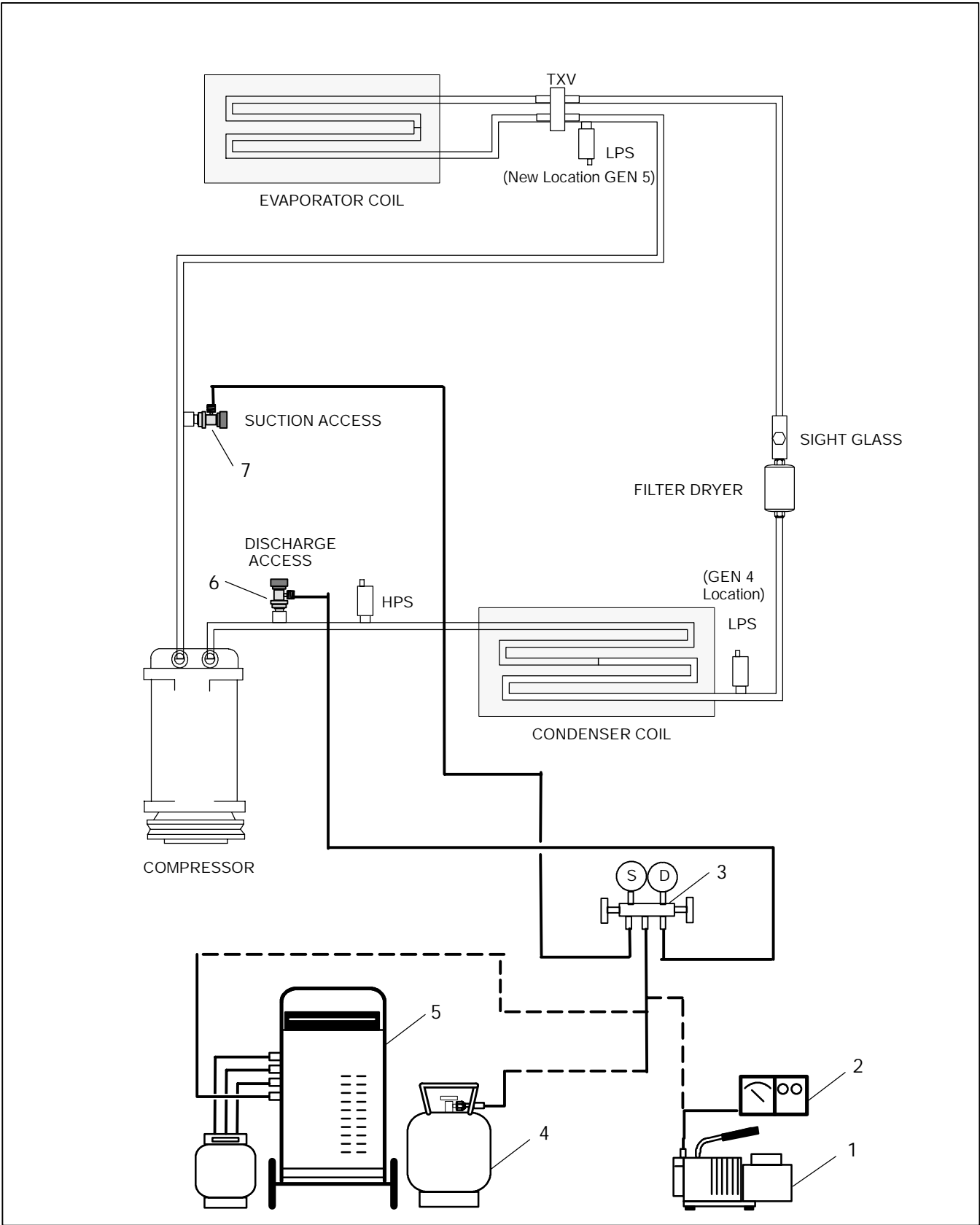

- |                         |  |
|-------------------------|--|
| 1. Vacuum Pump          | 5. Recovery/Recycle Machine            |
| 2. Micron Gauge         | 6. R134a High (Discharge) Side Coupler |
| 3. Manifold Gauge Set   | 7. R134a Low (Suction) Side Coupler    |
| 4. Refrigerant Cylinder |  |

**Figure 9-1 Refrigerant Service Connections (Split Systems)**

## SECTION 10

### WARRANTY REGISTRATION

#### 10.1 INTRODUCTION

The warranty registration process is an important part of the installation of any air conditioning system. In order to experience the full benefits of Carrier Transport Air Conditioning's warranty, it is imperative that your system is registered completely and accurately. Failure to properly register the system will adversely affect the availability of warranty coverage. A properly registered system will enable Carrier Transport Air Conditioning to respond immediately in the event of a warrantable failure.

#### 10.2 PROCEDURES

Locate the warranty registration card that is inclosed with the installation kit. (See Figure 10-1).

The warranty registration card consists of three (3) copies.

##### 1. Yellow copy: Installer copy:

- Completely fill out all Installer and Product information. Date of Installation, Installer Name, Address, City, State, Zip code and Phone number.
- When Purchaser information is known, the installer can complete this part of the form also.

- If the Warranty Registration Card is complete, the white (pre-addressed) copy can be mailed to Carrier Transport Air Conditioning at this time.
- Installer to keep yellow copy for file.
- Installer to forward (with bus) green and white copy to purchaser (end-user).

##### 2. Green copy: Purchaser (End User) copy:

- Complete Purchaser copy, sign, then mail white (pre-addressed) copy to Carrier Transport Air Conditioning.
- Purchaser (end user) to keep green copy for file.

#### NOTE

The Carrier Transport Air Conditioning limited warranty is printed on the back of the purchaser (green) copy.

##### 3. White Copy: Carrier Transport Air Conditioning copy:

- Must be mailed to Carrier Transport Air Conditioning in order to validate the system warranty.

**Carrier**  
**TRANSICOLD**  
**A/C INDUSTRIES**  
Subsidiary of Carrier Corporation  
115 Wilcox Springs Lane, York, PA 17402  
(717) 767-8521 Fax: (717) 764-0401 (800) 673-2431

**WARRANTY REGISTRATION CARD**  
This Registration Card must be completely filled out and the appropriate copy returned to A/C Industries to validate the A/C Industries Factory Warranty. The Purchaser's Signature below indicates that the Purchaser is familiar with the terms and conditions as set forth in our Warranty No. 410-001.

**PURCHASER**  
Name \_\_\_\_\_  
Address \_\_\_\_\_  
City \_\_\_\_\_ ST \_\_\_\_\_ ZIP \_\_\_\_\_  
Phone \_\_\_\_\_  
Purchaser Signature \_\_\_\_\_

**INSTALLER**  
Date of Installation \_\_\_\_\_  
Name \_\_\_\_\_  
Address \_\_\_\_\_  
City \_\_\_\_\_ ST \_\_\_\_\_ ZIP \_\_\_\_\_  
Phone \_\_\_\_\_

**PRODUCT INFORMATION**  
Bus Model \_\_\_\_\_  
Date In Service \_\_\_\_\_  
Refrigerant Type R\_\_\_\_\_

Serial Numbers of Appropriate A/C Industries Products

	Serial Number
Evaporator	_____
Condenser	_____
Compressor	_____
Power Unit	_____

Copy to be retained by installer Reg. Card No. 410-001

Figure 10-1 Warranty Registration Card

#### 10.3 WARRANTY POLICY

##### 10.3.1 In-Line Failures - OEM/Installer Repair

Refer to Warranty Policy, Procedures & Labor

Allowance Manual (62-02737) for instructions on returning, replacing or repairing any parts that were defective at time of installation. Or call Carrier Transport Air Conditioning Technical Support Hot-Line (800) 450-2211 for assistance.

**SECTION 11**  
**FINAL (CHECK-OUT SHEET)**

**INSTALLATION CHECK-OUT**

The installation checkout procedure is an important step in the installation of any air conditioning system. The reason for the installation checkout procedure is to insure that all Carrier Transport Air Conditioning standards of installation quality have been met. An itemized checkout form will help you in the checkout process and will provide a device for permanently recording your findings. The form that follows this introduction represents a guideline, that can be used as is, or as a starting point for the development of your own custom installation checkout sheet. A correctly completed final checkout will guarantee a quality installation that will last the life of the bus.

**GENERAL INFORMATION**

BUS MODEL/BODY \_\_\_\_\_ BUS VIN# \_\_\_\_\_

CARRIER TAC SYSTEM \_\_\_\_\_ EVAP'S \_\_\_\_\_ COND'S \_\_\_\_\_ COMP'S \_\_\_\_\_

**ENGINE AREA:**

**YES      NO**

- |                          |                          |  |
|--------------------------|--------------------------|--|
| <input type="checkbox"/> | <input type="checkbox"/> | Is compressor and compressor mount secure?   |
| <input type="checkbox"/> | <input type="checkbox"/> | Were bolts torqued to proper specifications when noted on mount kit drawing?   |
| <input type="checkbox"/> | <input type="checkbox"/> | Is there good alignment between the compressor, idler and crank pulley? Always use a straight edge to determine alignment. Eye sighting is not good enough!  |
| <input type="checkbox"/> | <input type="checkbox"/> | Were belts tightened per manufacturers recommendations?  |
| <input type="checkbox"/> | <input type="checkbox"/> | Are refrigerant hoses routed through the engine compartment to the compressor correctly? Refrigerant hose must be protected from heat sources and sharp objects! Refrigerant hose should be supported with insulated clamps wherever possible. |
| <input type="checkbox"/> | <input type="checkbox"/> | Was <u>mineral oil</u> used to lubricate the fittings, hose and O Rings?   |
| <input type="checkbox"/> | <input type="checkbox"/> | Was excess oil wiped from fittings and hose?   |
| <input type="checkbox"/> | <input type="checkbox"/> | Is 12.5 Volts available at the compressor clutch?  |
| <input type="checkbox"/> | <input type="checkbox"/> | Are the Quick-Click fittings clamped to the Quick-Click refrigerant hose correctly?  |

**CONDENSER AREA:**

**YES      NO**

- |                          |                          |   |
|--------------------------|--------------------------|---|
| <input type="checkbox"/> | <input type="checkbox"/> | Is the condenser(s) mounted securely to the bus floor?  |
| <input type="checkbox"/> | <input type="checkbox"/> | Is condenser(s) mounted as close as possible to bus skirt? If condenser cannot be mounted close to the skirt, a shroud must be installed to prevent re-circulation of heat. |
| <input type="checkbox"/> | <input type="checkbox"/> | Is bus skirt cut out to allow maximum airflow across the coil? Cut out must be at least as large as the condenser coil to allow for maximum heat rejection.                 |



## INSTALLATION CHECK-OUT, CONDENSER - Continued:

- \_\_\_      \_\_\_      Was mineral oil used to lubricate the fittings, hose and O Rings?
- \_\_\_      \_\_\_      Was excess oil wiped from fittings and hose?
- \_\_\_      \_\_\_      Are the Quick-Click fittings clamped to the Quick-Click refrigerant hose correctly?
- \_\_\_      \_\_\_      Are the refrigeration hoses routed to the condenser(s) properly?
- \_\_\_      \_\_\_      Are all the condenser fans blowing air in the proper direction?
- \_\_\_      \_\_\_      Is 12.5 Volts available at the condenser?
- \_\_\_      \_\_\_      Are exposed terminals/connections protected with an anti-corrosive coating?
- \_\_\_      \_\_\_      **If and when needed, is condenser(s) protected from road-sling?**
- \_\_\_      \_\_\_      Is condenser properly grounded to the chassis?

## EVAPORATOR AREA:

YES      NO

- \_\_\_      \_\_\_      Is evaporator(s) mounted securely to the bus roof? Either through the roof using hardware supplied by Carrier Transport Air Conditioning or by approved OEM supplied mounting brackets?
- \_\_\_      \_\_\_      If evaporator is mounted with carriage bolts through the roof, are the roof rails and bolts tight and sealed with caulking?
- \_\_\_      \_\_\_      Are refrigeration hoses routed properly? In hose covers or in the skin of the bus.
- \_\_\_      \_\_\_      Are all refrigerant hoses, electrical harnesses and drain lines properly supported and protected from sharp edges?
- \_\_\_      \_\_\_      Are two drain lines installed and running to opposite sides of the bus?
- \_\_\_      \_\_\_      Are drain lines running downhill?
- \_\_\_      \_\_\_      Are condensate valves (Kazoos) installed on drain line outlets?
- \_\_\_      \_\_\_      Are the Quick-Click fittings crimped to the Quick-Click refrigerant hose correctly?
- \_\_\_      \_\_\_      Is suction fitting and block valve (TXV) wrapped with no-drip tape to prevent condensate drip?
- \_\_\_      \_\_\_      Is suction hose covered with insulation to prevent condensate drip?
- \_\_\_      \_\_\_      Are butt connections properly crimped? Are all connections tight?
- \_\_\_      \_\_\_      Are blowers/fans running in the proper direction? Pushing air into the passenger compartment (free blow), or pulling air into the evaporator (ducted).
- \_\_\_      \_\_\_      Is 12.5 Volts available at the evaporator(s)?

## INSTALLATION CHECK-OUT, EVAPORATOR - Continued

- \_\_\_    \_\_\_    Are evaporators properly grounded?
- \_\_\_    \_\_\_    If ducted system, is ductwork properly mounted and trimmed?
- \_\_\_    \_\_\_    Are all required grills/louvers installed in the ductwork?

## REFRIGERATION HOSE AND ELECTRICAL HARNESS ROUTING:

- | YES | NO  |   |
|-----|-----|---|
| ___ | ___ | Is wiring harnesses and refrigerant hoses protected from sharp edges, heat sources and moving parts?                                    |
| ___ | ___ | Are insulated clamps used to support the hose and harness? Tie-wraps should only be used to bundle together wiring and hose assemblies. |
| ___ | ___ | Are electrical connections secure and protected from the environment?   |
| ___ | ___ | Are controls located within easy reach of the driver?   |
| ___ | ___ | Is there a workable service loop at all refrigerant hose connections?   |
| ___ | ___ | Is system free of refrigerant hose kinks and twists?  |
| ___ | ___ | Are circuit breakers located within 24 inches of the power source?  |
| ___ | ___ | Are relays, circuit breakers and controls located in an area with adequate ventilation?   |
| ___ | ___ | Is the electrical panel properly grounded?  |

## SYSTEM OPERATION:

- | YES | NO  |   |
|-----|-----|---|
| ___ | ___ | Is a Micron Gauge used during evacuation?   |
| ___ | ___ | Was 1000 microns or less reached during evacuation?   |
| ___ | ___ | Do evaporator blower speeds react to low, medium and high-speed settings?   |
| ___ | ___ | Turning thermostat counterclockwise and then clockwise, does compressor turn off and then on? If a dual system, verify thermostat and pressure switch wiring is connected to the proper system. |
| ___ | ___ | Is freeze-up thermostat (located in evaporator) properly adjusted? Turn counterclockwise to end, then clockwise 1/4 turn.   |
| ___ | ___ | Has refrigerant and oil charge been noted on the charging label?  |
| ___ | ___ | Is charging label attached as closely as possible to the compressor?  |
| ___ | ___ | Is warranty card completed? Sent to Carrier?  |



## 11.1 SYSTEM REQUIREMENTS LABEL

The system requirements label must be conveniently located within the vehicle's engine compartment. This label, when properly completed by the installer, will give the servicing technician the refrigerant and oil charge(s), evaporator(s), condenser(s), and compressor(s) serial numbers, the drive belt(s) number, mount kit number, the date of installation and the installer (See Figure 11-1).

### 11.1.1 System Requirement Label Completion

To complete the system requirement label do the following:

1. Lift the protective acetate cover to expose the blue and white data tag.
2. Enter the serial numbers of the (system components) compressor(s), evaporator(s), and condenser(s) where designated on the tag.
3. Enter the type of refrigerant used and the amount that was placed into each system, in pounds and

ounces. If this is a dual system, designate on tag which system (#1 or #2) is front (F) or rear (R), drivers (D) or passenger (P) side.

4. Enter (print) the type oil used and the amount, in ounces.
5. Enter the compressor(s) drive belt(s) part number or length.
6. Enter the mount kit (if used) part number.
7. Enter (print) your company's name (Installer).
8. Enter the date the installation was completed.
9. Determine where the label will be placed within the engine compartment. Wipe that area clean.
10. Remove the covering from the back of the label, exposing the adhesive surface. Place the label in the pre-determined location.
11. Carefully remove the protective covering from the clear acetate. Carefully smooth the protective acetate over the data tag label.

	<b>AIR CONDITIONING SYSTEM</b>	<b>SERVICE 1-800-450-2211</b>
		<b>PARTS 1-800-255-7382</b>
SER. NOS.	COMP. #1 <u>C090833</u>	#2 <u>C090936</u>
EVAP. #1 <u>51-004120</u>	#2 <u>51-004148</u>	#3 _____
COND. #1 <u>107-080187</u>	#2 <u>07-080188</u>	
REFRIGERANT TYPE <u>R-134a</u>	#1-QTY. <u>5</u> LBS. <u>5</u> OZ.	#2-QTY. <u>5</u> LBS. <u>9</u> OZ.
OIL TYPE <u>PAG-SANDEN</u>	#1-QTY. <u>11</u> OZ.	#2-QTY. <u>11.8</u> OZ.
BELT NO. CURB SIDE <u>17455</u>	MOUNT KIT NO.	
BELT NO. ROAD SIDE <u>601-227</u>	<u>050-169</u>	
INSTALLER <u>THE BUS CO.</u>	DATE <u>11-27-02</u>	

Figure 11-1 System Requirements Label

## A

Aesthetics, 2-1  
AUXILIARY HEATER HOSE ROUTING, 4-9

## B

Barrier Type Hose & Fittings, 4-1  
Belt Clearance, 6-2  
Blower Wheels, 2-1  
Bus Headliners, 2-1

## C

Cap Plugs, 2-1  
CHASSIS HOSE ROUTING, 4-6  
CM-2 AND CM-3 STACKED COND., 3-12  
Cm-5 CONDENSER, 3-5  
Cm-7, CM-11 ROOFTOP CONDENSER, 3-6  
Component Connections, 5-1  
COMPRESSOR HOSE ROUTING, 4-8  
COMPRESSOR INSTALLATION, 6-4  
CONDENSER HOSE ROUTING, 4-7  
CONDENSERS, 1-7, 3-2  
Connection Lubrication (Mineral Oil), 4-1  
CONTROLS, 5-2  
COOLING CYCLE, 1-4

## D

Drain Lines, 2-1  
Drive Belt Tension-Guidelines, 6-4  
Dual Systems, 4-1, 5-1

## E

Electrical Control Panel, 5-3  
Electrical Kits, 5-1

## INDEX

EM-17 EVAPORATOR, 2-15  
EM-20, EM-21 & EM-22 EVAPORATORS, 2-15  
EM-3 EVAPORATOR, 2-7  
EM-9 DUCTED EVAPORATOR , 2-12  
Evaporator Chassis Ground, 5-2  
Evaporator Chassis Ground, Gen 4 , 5-1  
EVAPORATOR HOSE ROUTING, 4-1, 4-5  
Evaporator Tie-In, 8-2  
EVAPORATORS, 1-6

## I

INSTALLATION CHECK-OUT, 11-1  
Installation Position, 6-4  
INSTALLING MANIFOLD GAUGES, 7-2  
Installing Manifold Guages, 7-2  
INTRODUCTION, 1-1, 2-1  
IW-1, IW-2, IW-7 & IW-14 EVAPS, 2-15

## K

KR-4 ROOFTOP CONDENSER , 3-10

## L

Leak Checking, 9-1  
Liquid Charging , 8-1

## M

Manual controls, 5-2  
Measuring Methods for Belt Tension, 6-4  
Micron (Vacuum) Gauge, 9-1  
Mounting (Rooftop), 3-1  
Mounting Compressors, 6-4

## N

Nitrogen, 9-1

## INDEX

### O

Obstructions, 3-1  
Oil Charge, 6-5  
Oil Charge , 8-1  
OPERATING INSTRUCTIONS , 5-4

### P

PAG And POE Oils , 8-1  
PIPING DIAGRAMS, 4-9  
PRE-INSTALLATION, 1-7  
PREVENTATIVE MAINTENANCE, 3-1  
PROCEDURES, 10-1  
Pulley Alignment, 6-3

### Q

Quick-Click Hose & Clamps, 4-1

### R

R134a Charge, 8-1  
REAR MOUNTED EVAPORATORS, 2-2  
Requirements Label, 1-1  
ROOFTOP CONDENSER HOSE ROUTING, 4-9

### S

Serial Number Tags , 1-1  
Service Loop, 4-1  
SERVICE TOOLS, 7-1  
SIDE MOUNTED EVAPORATOR, 2-9  
Skirt Supports, 3-1  
SKIRT MOUNTED CONDENSERS, 3-2  
SYSTEM COMPONENTS, 1-3  
SYSTEM NOMENCLATURE, 1-1  
SYSTEM REQUIREMENTS LABEL, 11-5  
SYSTEM WIRING , 5-1

### T

TORQUE SPECIFICATIONS, 6-2  
TOTAL CONTROL, 5-3  
Total Control Key Pad/Display, 5-3  
TROUBLESHOOTING, 2-1

### V

VOLTAGES, 5-1

### W

WIRING SCHEMATICS, 4-1