



Transport Air Conditioning



OPERATION AND SERVICE  
for  
**EM-17**  
Large Split Systems  
DC12174 & DC12175



**TRANSICOLD**

---

# **OPERATION & SERVICE MANUAL**

## **BUS AIR CONDITIONING EQUIPMENT**

**MODEL  
EM-17  
Large Split System  
DC12174  
DC12175**

# TABLE OF CONTENTS

Section .....	Page
<b>SAFETY SUMMARY .....</b>	<b>Safety-1</b>
<b>DESCRIPTION .....</b>	<b>1-1</b>
1.1 INTRODUCTION .....	1-1
1.1.1 Evaporator Section (EM-17) .....	1-1
1.1.2 Condensing Section .....	1-1
1.1.3 Compressor Assembly .....	1-1
1.2 SYSTEM OPERATING CONTROLS AND COMPONENTS .....	1-3
1.3 PANEL ASSEMBLY, CONTROL BOX .....	1-3
1.4 REFRIGERANT SYSTEM COMPONENT SPECIFICATIONS .....	1-4
1.5 SAFETY DEVICES .....	1-5
1.6 ELECTRICAL SPECIFICATIONS - EVAPORATOR (EM-17) MOTOR .....	1-5
1.7 ELECTRICAL SPECIFICATIONS - Condenser (CM-5) Fan MotorS .....	1-5
1.8 ELECTRICAL SPECIFICATIONS SENSORS .....	1-5
1.9 SAFETY DEVICES .....	1-6
1.10 AIR CONDITIONING REFRIGERATION CYCLE .....	1-6
<b>OPERATION .....</b>	<b>2-1</b>
2.1 STARTING AND STOPPING INSTRUCTIONS .....	2-1
2.1.1 Starting .....	2-1
2.1.2 Stopping .....	2-1
2.2 PRE-TRIP-INSPECTION .....	2-1
2.3 UNIT OPERATION .....	2-1
2.3.1 Temperature Control .....	2-1
2.3.2 Cooling Mode .....	2-1
2.3.3 Vent Mode .....	2-1
2.3.4 Compressor Unloader Control .....	2-1
2.3.5 Condenser Fan Control .....	2-2
2.3.6 Compressor Clutch Control .....	2-2
2.3.7 Liquid Line Solenoid Control .....	2-2
2.4 SEQUENCE OF OPERATION .....	2-2
<b>TROUBLESHOOTING .....</b>	<b>3-1</b>
3.1 System Will Not Cool .....	3-1
3.2 System Runs But Has Insufficient Cooling .....	3-1
3.3 Abnormal Pressures .....	3-1
3.4 Abnormal Noise Or Vibrations .....	3-1
3.5 Control System Malfunction .....	3-2
3.6 No Evaporator Air Flow Or Restricted Air Flow .....	3-2
3.7 Expansion Valve Malfunction .....	3-2
3.8 Heating Malfunction .....	3-2
<b>SERVICE .....</b>	<b>4-1</b>
4.1 MAINTENANCE SCHEDULE .....	4-1
4.2 SUCTION AND DISCHARGE SERVICE VALVES .....	4-1
4.3 INSTALLING MANIFOLD GAUGE SET .....	4-2

## TABLE OF CONTENTS - Continued:

4.4	PUMPING THE SYSTEM DOWN OR REMOVING THE REFRIGERANT CHARGE	4-3
4.4.1	System Pump Down For Low Side Repair	4-3
4.4.2	Refrigerant Removal From An Inoperative Compressor.	4-4
4.4.3	Pump Down An Operable Compressor For Repair	4-4
4.4.4	Removing Entire System Charge	4-5
4.5	REFRIGERANT LEAK CHECK	4-5
4.6	EVACUATION AND DEHYDRATION	4-5
4.6.1	General	4-5
4.6.2	Preparation	4-5
4.6.3	Procedure for Evacuation and Dehydrating System (Triple Evacuation)	4-5
4.6.4	Procedure for Evacuation and Dehydrating System (One Time Evacuation)	4-6
4.7	ADDING REFRIGERANT TO SYSTEM	4-7
4.7.1	Checking Refrigerant Charge	4-7
4.7.2	Adding Full Charge	4-7
4.7.3	Adding Partial Charge	4-7
4.8	CHECKING FOR NONCONDENSIBLES	4-7
4.9	CHECKING AND REPLACING HIGH OR LOW PRESSURE SWITCH	4-7
4.10	REMOVING TOP COVER (KR-4 CONDENSER)	4-8
4.11	FILTER-DRIER	4-8
4.11.1	To Check Filter-Drier	4-8
4.11.2	To Replace Filter-Drier	4-8
4.12	SERVICING THE LIQUID LINE SOLENOID VALVE	4-9
4.12.1	Coil Replacement	4-9
4.12.2	Internal Part Replacement	4-9
4.12.3	Replace Entire Valve	4-9
4.13	THERMOSTATIC EXPANSION VALVE	4-9
4.13.1	Valve Replacement	4-10
4.13.2	Superheat Measurement	4-10
4.14	REPLACING RETURN AIR FILTERS	4-10
4.15	COMPRESSOR MAINTENANCE	4-11
4.15.1	Removing the Compressor	4-11
4.15.2	Transferring Compressor Clutch	4-12
4.15.3	Compressor Oil Level	4-12
4.15.4	Compressor Electric Unloader Operation	4-13
4.16	TEMPERATURE SENSOR CHECKOUT	4-13
4.17	REPLACING SENSORS	4-14
4.18	ELECTRIC COMPRESSOR UNLOADERS	4-14
<b>ELECTRICAL</b>		<b>5-1</b>
5-1	INTRODUCTION	5-1

## LIST OF ILLUSTRATIONS

<b>Figure</b> .....	<b>Page</b>
Figure 1-1 Coach Cutaway View .....	1-2
Figure 1-2 Panel Assembly, Control Box .....	1-3
Figure 1-3 Relay Board .....	1-4
Figure 1-4 Refrigerant Flow Diagram (DC12175) .....	1-7
Figure 1-5 Refrigerant Flow Diagram DC12174 .....	1-8
Figure 2-1 Thermostat Control Sequence .....	2-1
Figure 4-1 Suction or Discharge Service Valve .....	4-2
Figure 4-2 Manifold Gauge Set .....	4-2
Figure 4-3 Manifold Gauge Set (R-134a) .....	4-3
Figure 4-4 Low Side Pump Down Connections .....	4-4
Figure 4-5 Compressor Service Connections .....	4-4
Figure 4-6 System Charge Removal Connections .....	4-5
Figure 4-7 Vacuum Pump Connections .....	4-6
Figure 4-8 Checking High Pressure Switch .....	4-8
Figure 4-9 Condenser Cover Removal .....	4-8
Figure 4-10 Filter-Drier Removal .....	4-8
Figure 4-11 Liquid Line Solenoid Valve .....	4-9
Figure 4-12 Thermostatic Expansion Valve .....	4-10
Figure 4-13 Thermostatic Expansion Valve Bulb and Thermocouple .....	4-10
Figure 4-14 Compressor .....	4-11
Figure 4-15 Removing Bypass Piston Plug .....	4-11
Figure 4-16 Compressor Clutch .....	4-12
Figure 4-10. Electric Unloader Schematic .....	4-14
Figure 5-1 Electrical Control Panel Relay Board (RB) & Electronic Thermostat (TH) Outline Views. . .	5-1
Figure 5-2 Schematic .....	5-2

## LIST OF TABLES

<b>Table</b> .....	<b>Page</b>
Table 1-1 Model .....	1-2
Table 1-2 Additional Support Manuals .....	1-2
Table 1-3 Unloader Pressure Switch Settings (R-134a) .....	1-4
Table 1-4 Safety Devices .....	1-5
Table 3-1 General System Troubleshooting Procedures .....	3-1
Table 4-1 Temperature Sensor Resistance .....	4-13
Table 4-2 R-134a Temperature - Pressure Chart .....	4-15

# SAFETY SUMMARY

## GENERAL SAFETY NOTICES

The following general safety notices supplement the specific warnings and cautions appearing elsewhere in this manual. They are recommended precautions that must be understood and applied during operation and maintenance of the equipment covered herein. The general safety notices are presented in the following three sections labeled: First Aid, Operating Precautions and Maintenance Precautions. A listing of the specific warnings and cautions appearing elsewhere in the manual follows the general safety notices.

## FIRST AID

An injury, no matter how slight, should never go unattended. Always obtain first aid or medical attention immediately.

## OPERATING PRECAUTIONS

Always wear safety glasses.

Keep hands, clothing and tools clear of the evaporator, condenser fans & compressor clutch.

No work should be performed on the system until all circuit breakers and start-stop switches are placed in the OFF position, and power supply is disconnected.

Always work in pairs. Never work on the equipment alone.

In case of severe vibration or unusual noise, stop the system and investigate.

## MAINTENANCE PRECAUTIONS

Beware of unannounced starting of the evaporator and condenser fans, and compressor clutch. Do not open the unit cover before turning power off.

Be sure power is turned off before working on motors, controllers, solenoid valves and electrical controls. Tag circuit breaker and power supply to prevent accidental energizing of circuit.

Do not bypass any electrical safety devices, e.g. bridging an overload, or using any sort of jumper wires. Problems with the system should be diagnosed, and any necessary repairs performed, by qualified service personnel.

When performing any arc welding on the unit, disconnect all wire harness connectors from the modules in the control box. Do not remove wire harness from the modules unless you are grounded to the unit frame with a static-safe wrist strap.

In case of electrical fire, open circuit switch and extinguish with CO<sub>2</sub> (never use water).

## SAFETY SUMMARY

### SPECIFIC WARNINGS AND CAUTIONS

 **WARNING**

Be sure to observe warnings listed in the safety summary in the front of this manual before performing maintenance on the hvac system

 **WARNING**

Read the entire procedure before beginning work. Park the coach on a level surface, with parking brake applied. Turn main electrical disconnect switch to the off position.

 **WARNING**

Do not use a nitrogen cylinder without a pressure regulator.

 **WARNING**

Do not use oxygen in or near a refrigeration system as an explosion may occur.

 **WARNING**

The filter-drier may contain liquid refrigerant. Slowly loosen the flare nuts to avoid refrigerant contact with exposed skin or eyes.

 **WARNING**

Extreme care must be taken to ensure that all the refrigerant has been removed from the compressor crankcase or the resultant pressure will forcibly discharge compressor oil.

 **WARNING**

Beware of rotating fan blades and unannounced starting of fans or compressor.

 **CAUTION**

To avoid the entrance of air, never evacuate an open drive compressor below 500 microns.

 **CAUTION**

To prevent trapping liquid refrigerant in the manifold gauge set be sure set is brought to suction pressure before disconnecting.

## SECTION 1

### DESCRIPTION

#### 1.1 INTRODUCTION

This manual contains Operating Instructions, Service Instructions and Electrical Data for the Model DC12175 and DC12174 Air Conditioning equipment furnished by Carrier Transport Air Conditioning as shown in Table 1-1. Additional support manuals are referenced in Table 1-2.

The Model DC12175 system consists of a CM-5 condensing unit, an EM-17 evaporator section and a rear engine compartment mounted 05G compressor.

The Model DC12174 system consists of a KR-4 rooftop condensing unit, an EM-17 evaporator section and a rear engine compartment mounted 05G compressor.

#### NOTE

An optional 05K compressor can be used in place of the 05G in lighter duty applications.

To complete the systems, the air conditioning equipment interfaces with electrical cabling, refrigerant piping, duct work and other components furnished by the bus manufacturer.

Information on the compressor(s) is provided in separately bound manuals. Refer to Table 1-2.

The drivers control is equipped with a single HIGH-OFF-LOW switch and A/C Stop Light. The switch is placed in the desired fan speed position to start temperature control. Operation of the system is controlled automatically by an electronic thermostat which maintains the vehicles interior temperature at the desired set point. Some systems may be configured to override the high speed selection to low speed once interior temperature approaches set point. The A/C Stop Light will be illuminated if the system is shut down on a safety.

Description of the system components are provided in the following sub paragraphs and illustrated in Figure 1-1 .

##### 1.1.1 Evaporator Section (EM-17)

The evaporator system includes the evaporator coil, fan and motor assemblies, a thermostatic expansion valve and condensate drain line connections. Also included with the evaporator assembly are UPS1, 2 & 3, CFS 1 & 2, a Liquid Line solenoid (LLS) and Condenser fan speed resistor.

The thermostatic expansion valve meters the flow of refrigerant entering the evaporator coil. The evaporator coil provides heat transfer surface for transferring heat from air circulating over the coil to refrigerant circulating inside the tubes; thus providing cooling. The optional heating coils provide heat transfer surface for transferring heat from engine coolant water circulating inside the tubes to air circulating over the outside

surface of the tubes; thus providing heating. The fans circulate the air over the coils. The air filters remove dirt particles from the air before it passes over the coils.

##### 1.1.2 Condensing Section

The condensing section includes the condenser coil (s) fan and motor assemblies, filter-drier, receiver (with sight glass and moisture indicator), discharge line check valve, discharge line connection, service valves, fusible plug and an ambient temperature sensor.

The discharge check valve is a spring loaded, normally closed valve that opens with the flow of refrigerant from the compressor. When the compressor clutch is disengaged, the discharge check valve will close, preventing the flow of high pressure liquid from the condenser back into the compressor.

The condenser coil provides heat transfer surface for condensing refrigerant gas at a high temperature and pressure into a liquid at high temperature and pressure. The condenser fans circulate ambient air across the outside of the condenser tubes at a temperature lower than the refrigerant circulating inside the tubes; this results in condensation of the refrigerant into a liquid.

The receiver collects and stores the liquid refrigerant. The receiver is fitted with liquid level sight glass to enable determination of refrigerant liquid level and moisture content. The receiver is also fitted with a fusible plug which protects the system from unsafe high pressure conditions. The filter-drier removes moisture and debris from the liquid refrigerant before it enters the thermostatic expansion valve. The service valves enable isolation of the filter-drier for service. The ambient temperature sensor opens below 50°F to prevent A/C operation

##### 1.1.3 Compressor Assembly

The compressor assembly includes the refrigerant compressor, clutch assembly, suction and discharge service valves, high pressure switch, low pressure switch, suction and discharge servicing (charging) ports and electrical solenoid unloaders.

The compressor raises the pressure and temperature of the refrigerant and forces it into the condenser. The clutch assembly provides a means to disengage the compressor from the bus engine. The suction and discharge service valves enable servicing of the compressor. Suction and discharge servicing (charging) ports mounted on the service valves enable connection of charging hoses for servicing of the compressor, as well as other parts of the refrigerant circuit. The high pressure switch contacts open on a pressure rise to shut down the system when abnormally high refrigerant pressures occur. The electric unloaders provide a means of controlling compressor capacity, which enables control of temperature inside the bus.



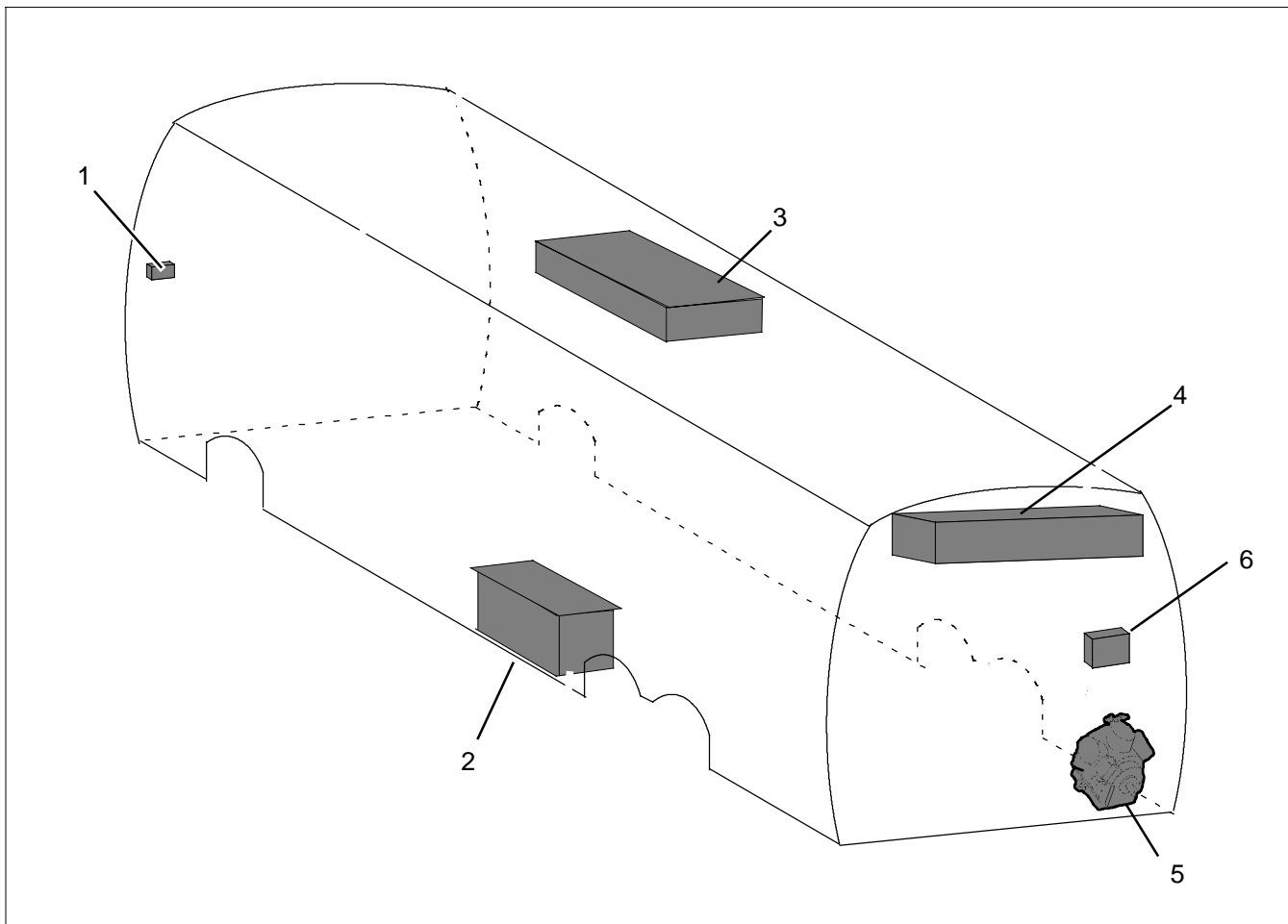

**Figure 1-1 Coach Cutaway View**

1 Drivers Control  
 2 CM-5 Condenser (DC12175)  
 3 KR-4 Rooftop Condenser (DC12174)

4 EM-17 Evaporator Assembly  
 5 Compressor Assembly  
 6 Control Box (TBB)

**Table 1-1 Model**

MODEL	VDC	ELECTRONIC THERMOSTAT	COMPRESSOR.	CONDENSOR	EVAPORATOR
DC12174	24	Yes	O5G	KR-4	EM-17 Single Loop
DC12175	24	Yes	O5G	CM-5	EM-17 Single Loop

**Table 1-2 Additional Support Manuals**

MANUAL/FORM NUMBER	EQUIPMENT COVERED	TYPE OF MANUAL
T-299PL	Split Systems Gen 4/5	Parts List
T-200PL (Old Style)	O5G Compressor	Parts List
62-02756 (Before SN xxxxx)	O5G & O5G Bus Compressor	Operation & Service
62-50400 (Old Style)	O5G Comp. & Housing Mtd. Clutch	Service Training
62-11052	Model O5G Twin Port Compressor	Workshop Manual
62-11053	Model O5G Twin Port Compressor	Service Parts
62-02460	(Optional) Model O5K Compressor	Service Parts
62-02491	(Optional) Model O5K Compressor	Operation & Service

## 1.2 SYSTEM OPERATING CONTROLS AND COMPONENTS

### 1 Electronic Thermostat (TH)

The system is equipped with an electronic thermostat which operates in combination with a separate relay board (See Figure 1-2 & Figure 1-3) to control the operation of the system.

The setpoint is adjusted by manually turning the control box mounted potentiometer towards "COOLER" or "WARMER".

The thermostat's temperature sensor monitors the vehicles interior temperature at the return air section of the evaporator and controls the operating function of the system to maintain the desired vehicle interior temperature.

## 2 Manual Switches

### A/C Mode Switch (ACMS)

The drivers control is equipped with a single HIGH-OFF-LOW switch. The switch is placed in the desired fan speed position to start temperature control.

## 3 Pressure Switches

### Condenser Fan Switches (CFS)

The condenser fan switches are located in the evaporator section. Switch CFS 1 controls the number of fans in operation while switch CFR2 controls fan speed.

## 1.3 PANEL ASSEMBLY, CONTROL BOX

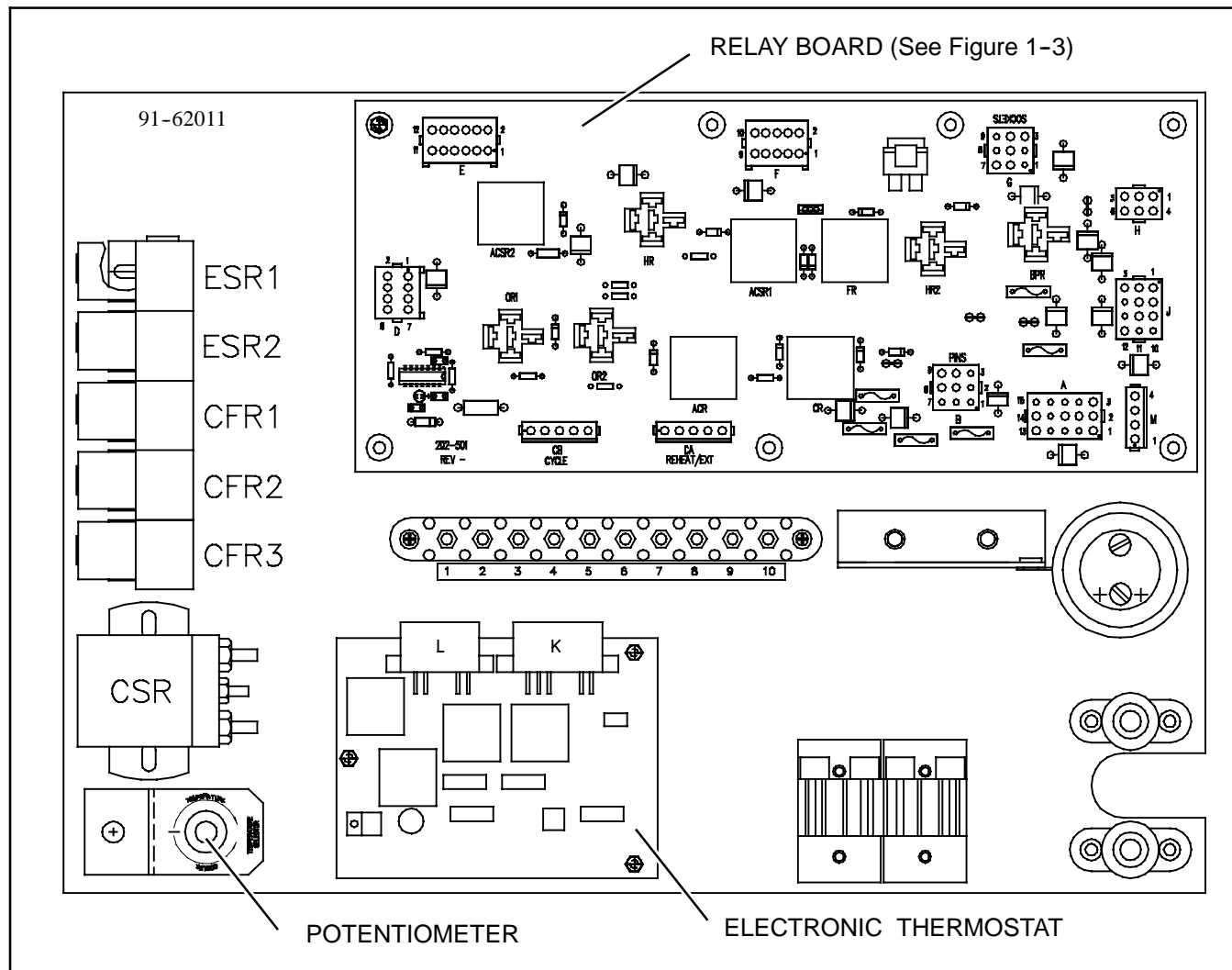

Figure 1-2 Panel Assembly, Control Box

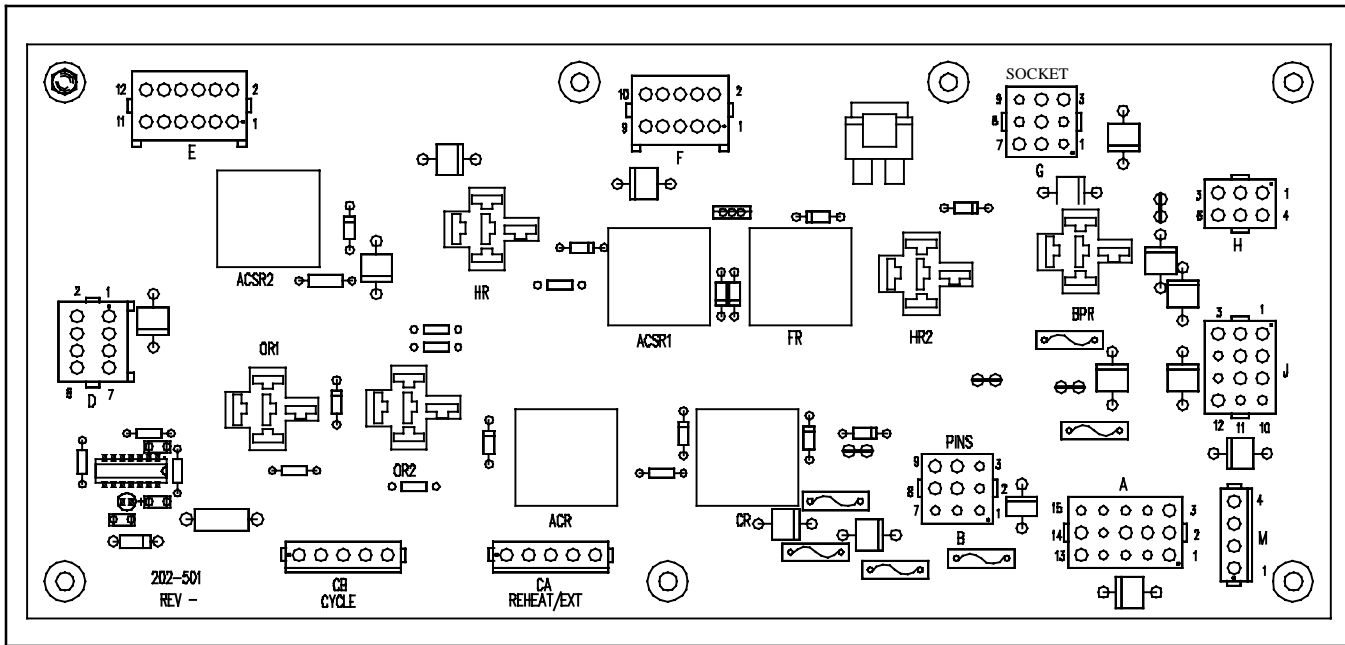

Figure 1-3 Relay Board

**1.4 REFRIGERANT SYSTEM COMPONENT SPECIFICATIONS**

**a. Refrigeration Charge**

Approximate R134a refrigerant charge will be between 14 and 19 pounds, dependent upon condenser type and placement.

**b. Compressors**

**Model: 05G**

No. of Cylinder: 6  
Weight (Dry): 145 lbs. (66 kg) including clutch

**Model: 05K**

No. of Cylinder: 4  
Weight (Dry): 108 lbs. (49 kg) including clutch

**c. 05G Compressor - Electric Unloader Pressure Switches UPS1, UPS2 and UPS3 (See Table 1-3)**

**NOTE**

Refer to 05g or 05K Operation and Service manuals for additional technical data, including approved oils and oil capacity.

**d. Thermostatic Expansion Valve**

Superheat Setting: 10°F (5.6°C)  
MOP Setting: 65.0 ±4 psig

**e. Condenser Fan Switches**

**CFS1**

Closes for 4 (DC12174) or 5 (DC12175) fan operation:

100 ±10 psig  
Opens for 2 fan operation: 80 ±15 psig

**CFS2**

Closes for high speed: 275 ±10 psig  
Opens for Low Speed: 220 ±15 psig

**f. Low Ambient Switch (LATH)**

Opens at: 50 ±3\_F ( 7.2\_C)  
Closes at: 60 ±3\_F (12.8\_C)

Table 1-3 Unloader Pressure Switch Settings (R-134a)

UNLOADER PRESSURE SWITCH - Contacts Open/Close Settings [psig (kg/cm <sup>2</sup> )]					
UPS1		UPS2		UPS3	
Load Up (Opens)	Unload (Closes)	Load Up (Opens)	Unload (Closes)	Load Up (Opens)	Unload (Closes)
34 ±3 (2.5 ±0.21)	26 ±2 (1.8 ±0.14)	31 ±2 (2.2 ±0.14)	23 ±2 (1.6 ±0.14)	250 ±15 (19 ±1.1)	320 ±10 (19 ±1.1)

## 1.5 SAFETY DEVICES

System components are protected from damage caused by unsafe operating conditions with safety devices listed in Table 1-4.

During A/C mode, operation will automatically stop if the High Pressure Switch (HPS) or Low Pressure Switch (LPS) contacts open due to an unsafe operating condition. Opening the High Pressure Switch (HPS) or Low Pressure Switch (LPS) contacts de-energizes the A/C compressor clutch. The A/C Stop Light will also illuminate indicating that an unsafe operating condition has occurred. The unit will then operate in VENT Mode.

The system circuits are protected independently against high current draw with fuses F2 & F4 through F14 and vehicle main power fuse. Refer to the schematic diagram in Section 5 for fuse locations.

When a safety device opens and causes the unit operation to stop, place the climate control switch to off position before resolving the problem. The safety device may need to be replaced before restarting the unit.

**Table 1-4 Safety Devices**

UNSAFE CONDITION	SAFETY DEVICE	DEVICE SETTING
Excessive current draw by system	Main Power Fuse	Opens at 150 amps
Excessive current draw by the control circuit	Fuse 2 & 4	Opens at 15 amps
Excessive current draw by the clutch coil or fault circuit	Fuse 5	Opens at 15 amps
Excessive current draw by any condenser motors no. 1 thru 4 (DC12174) or 5 (DC12175)	Fuses 6 thru 10	Opens at 15 amps
Excessive current draw by the ACMS or control circuit	Fuse 11	Opens at 15 amps
Excessive current draw by evaporator motor no. 1.	Fuse 12	Opens at 40 amps
Excessive current draw by evaporator motor no. 2.	Fuse 13	Opens at 40 amps
Excessive current draw by the condenser unit	Fuse 14	Opens at 60 amps
High system pressure	High Pressure Switch (HPS) Automatic Reset	Opens at 360   10 psig (23.81 ± 0.68bar) Closes at 285   10 psig (13.61 ± 0.68bar)
Low system pressure	Low Pressure Switch (LPS) Automatic Reset	Opens at 6   3 psig(0.41 ± 0.20 bar) Closes at 25   5 psig(1.7 ± 0.20 bar)

## 1.6 ELECTRICAL SPECIFICATIONS - EVAPORATOR (EM-17) MOTOR

### Permanent Magnet Motor

Bearing Lubrication: Factory Lubricated  
(additional grease not required)

Horsepower: 0.75  
Full Load Amps (FLA): 27 amps  
Operating Speed: 1800 rpm  
Voltage: 24 vdc

Horsepower: 0.8 hp  
Full Load Amps (FLA): 21/32 amps  
Operating Speed: 1600/1800 rpm  
Voltage: 24 vdc

## 1.7.1 CONDENSER FAN MOTOR KR-4

### Permanent Magnet Motor

Bearing Lubrication: Factory Lubricated  
(additional grease not required)

Horsepower: 0.8 hp  
Full Load Amps (FLA): 21/32 amps  
Operating Speed: 1600/1800 rpm  
Voltage: 24 vdc

## 1.7 ELECTRICAL SPECIFICATIONS - CONDENSER (CM-5) FAN MOTORS

### Permanent Magnet Motor

Bearing Lubrication: Factory Lubricated  
(additional grease not required)

## 1.8 ELECTRICAL SPECIFICATIONS

### SENSORS

#### a. Temperature Sensors

Input Range: 52.6 to 158°F (47 to 70°C)  
Output: NTC 10K ohms at 77°F (25°C)

## 1.9 SAFETY DEVICES

System components are protected from damage caused by unsafe operating conditions with safety devices. Safety devices with Carrier Transicold supplied equipment include high pressure switch (HPS), low pressure switch (LPS), circuit breakers and fuses.

### a. Pressure Switches

#### **High Pressure Switch (HPS)**

During the A/C mode, compressor operation will automatically stop if the HPS switch contacts open due to an unsafe operating condition. Opening HPS contacts de-energizes the compressor clutch, shutting down the compressor. The high pressure switch (HPS) is installed in the center head of the compressor.

#### **Low Pressure Switch (LPS)**

The low pressure switch is installed in the compressor and opens on a pressure drop to shut down the compressor clutch when a low pressure condition occurs.

### b. Ambient Lockout

The ambient temperature sensor located in the condenser section measures the condenser inlet air temperature. When the temperature has fallen below the cut out set point the compressor is locked out until the temperature rises above the cut in setting. The set point will be to cut out at  $50^{\circ}\text{F} \pm 3^{\circ}$  and cut in at  $60^{\circ}\text{F} \pm 3^{\circ}$ . This setting protects the compressor from damage caused by operation in low ambient conditions.

## 1.10 AIR CONDITIONING REFRIGERATION CYCLE

When air conditioning (cooling) is selected by the thermostat, the unit operates as a vapor compression system using R-134a as the refrigerant (See Figure 1-4 OR Figure 1-5). The main components of the system are the reciprocating compressor, air-cooled condenser coils, receiver, filter-drier, thermostatic expansion valve, liquid line solenoid valve and evaporator coils.

The compressor raises the pressure and the temperature of the refrigerant and forces it through the discharge check valve into the condenser tubes. The

condenser fan circulates surrounding air (which is at a temperature lower than the refrigerant) over the outside of the condenser tubes. Heat transfer is established from the refrigerant (inside the tubes) to the condenser air (flowing over the tubes). The condenser tubes have fins designed to improve the transfer of heat from the refrigerant gas to the air; this removal of heat causes the refrigerant to condense, thus liquid refrigerant leaves the condenser and flows to the receiver.

The receiver serves as a liquid refrigerant reservoir so that a constant supply of liquid is available to the evaporator as needed, and acts as a storage space when pumping down the system.

The refrigerant leaves the receiver and flows through the filter-drier where an absorbent keeps the refrigerant clean and dry. The liquid line may be equipped with a sight glass to observe the refrigerant for restricted flow and the correct charge level.

From the filter-drier, the liquid refrigerant then flows through the liquid line solenoid valve towards the thermostatic expansion valve. For the CM-5 condenser this flow is a direct path. For the KR-4 condenser, the refrigerant also passes through a subcooling circuit in the leaving condenser. The thermal expansion valve reduces pressure and temperature of the liquid and meters the flow of liquid (saturated mix) refrigerant to the evaporator to obtain maximum use of the evaporator heat transfer surface.

The low pressure, low temperature liquid (saturated mix) that flows into the evaporator tubes is colder than the air that is circulated over the evaporator tubes by the evaporator fans. Heat transfer is established from the evaporator air (flowing over the tubes) to the refrigerant (flowing inside the tubes). The evaporator tubes have aluminum fins to increase heat transfer from the air to the refrigerant; therefore the cooler air is circulated to the interior of the vehicle. Liquid line solenoid valve closes during shutdown to prevent refrigerant migration to the compressor.

The transfer of heat from the air to the low temperature liquid refrigerant in the evaporator causes the liquid to vaporize. This low temperature, low pressure vapor passes through the suction line and returns to the compressor where the cycle repeats.

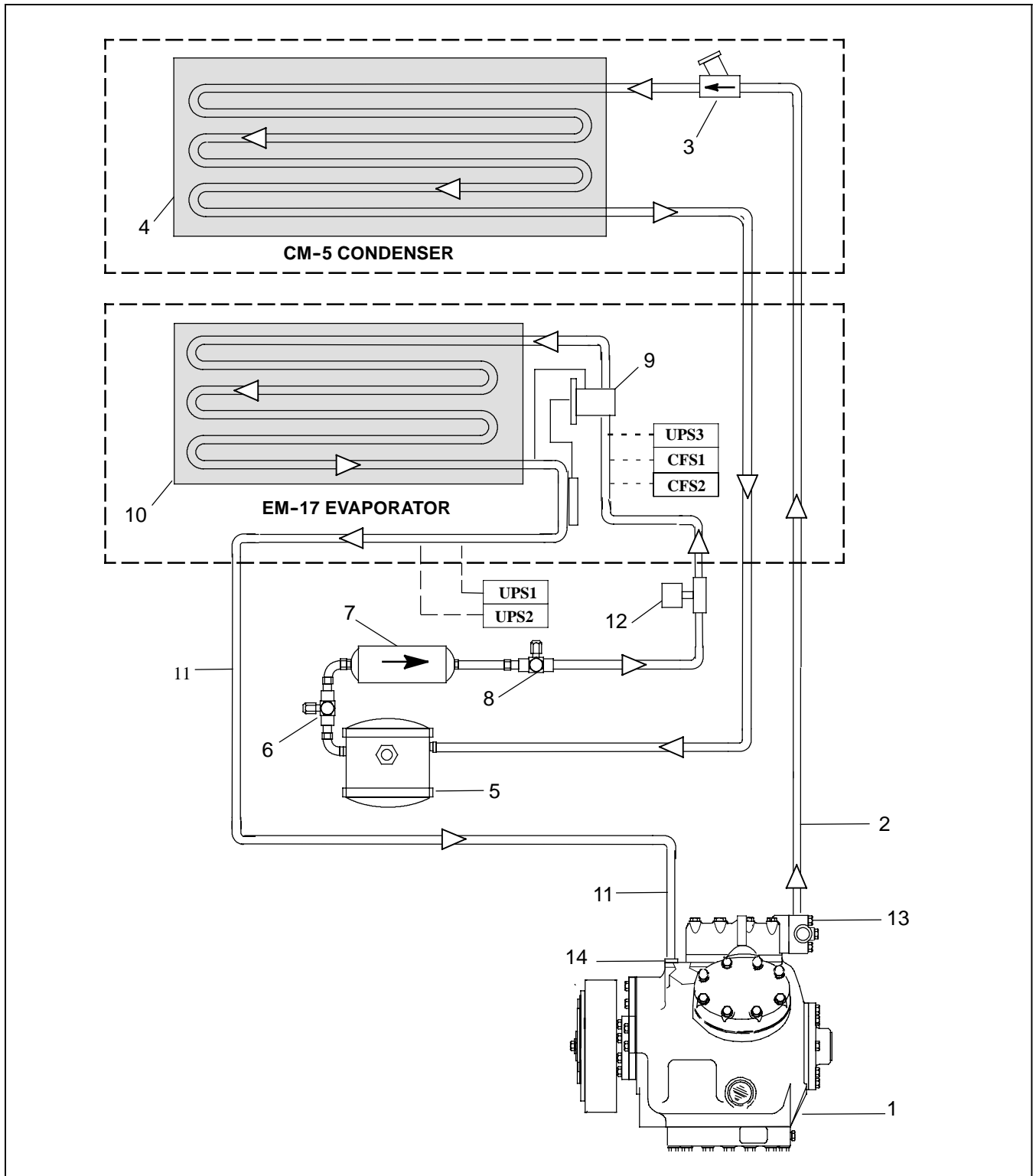

- |   |                            |    |                                  |
|---|----------------------------|----|----------------------------------|
| 1 | Compressor                 | 8  | Filter-Drier Outlet Valve        |
| 2 | Discharge Line             | 9  | Thermostatic Expansion Valve     |
| 3 | Discharge Line Check Valve | 10 | Evaporator Coil                  |
| 4 | Condenser Coil             | 11 | Suction Line                     |
| 5 | Receiver                   | 12 | Liquid Line Solenoid Valve (LSV) |
| 6 | Filter-Drier Inlet Valve   | 13 | Discharge Service Port           |
| 7 | Filter-Drier               | 14 | Suction Service Port             |

**Figure 1-4 Refrigerant Flow Diagram (DC12175)**

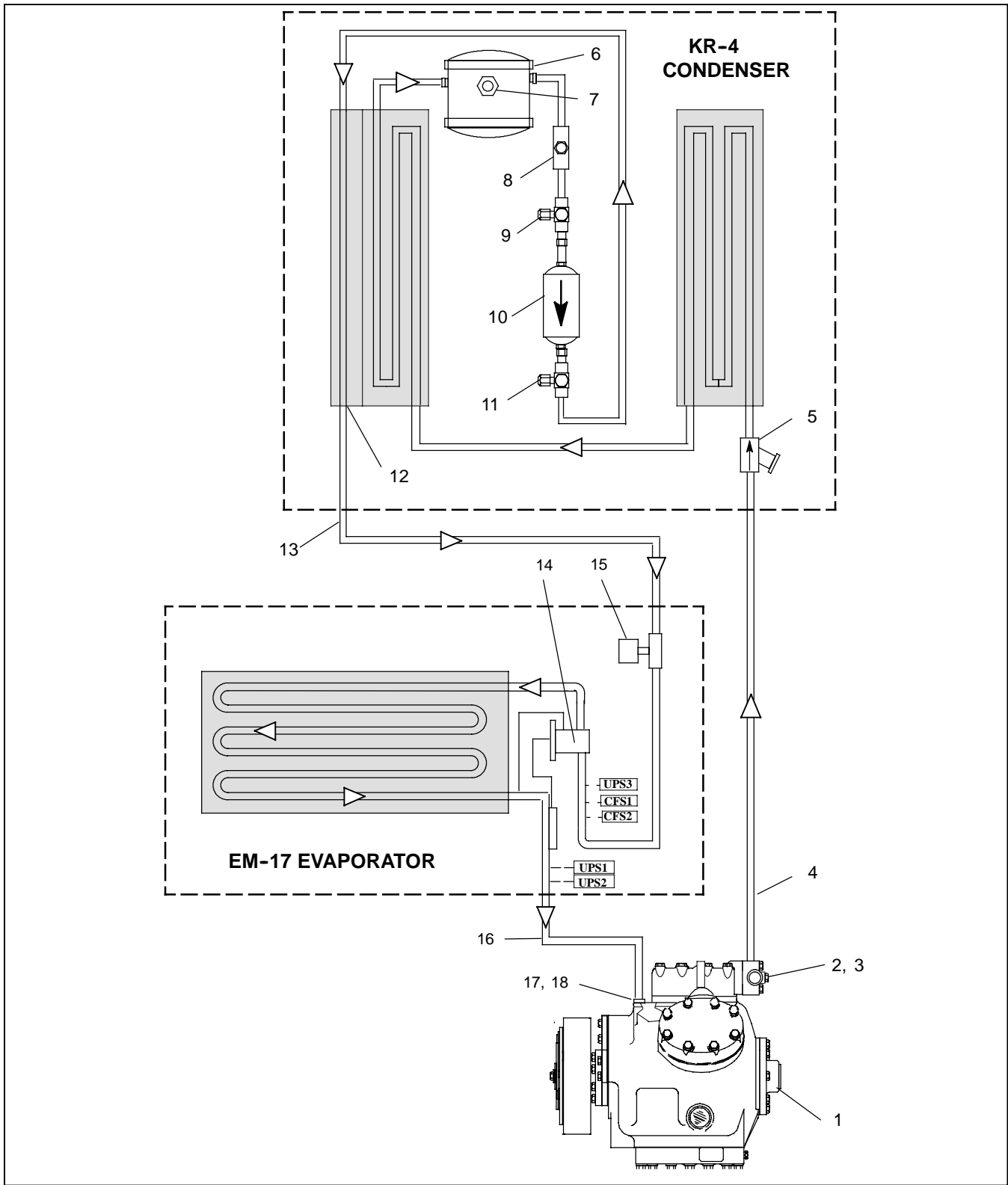

- |                             |                                      |
|-----------------------------|--------------------------------------|
| 1. Compressor               | 10. Filter Drier                     |
| 2. Discharge Service Port   | 11. Filter Drier Outlet Valve        |
| 3. High Pressure Switch     | 12. Subcooler                        |
| 4. Discharge Line           | 13. Liquid Line                      |
| 5. Discharge Check Valve    | 14. Liquid Line Solenoid Valve (LSV) |
| 6. Receiver                 | 15. Thermostatic Expansion Valve     |
| 7. Fusible Plug             | 16. Suction Line                     |
| 8. Sight Glass              | 17. Suction Service Port             |
| 9. Filter Drier Inlet Valve | 18. Low Pressure Switch              |

**Figure 1-5 Refrigerant Flow Diagram DC12174**

## SECTION 2

### OPERATION

#### 2.1 STARTING AND STOPPING INSTRUCTIONS

##### 2.1.1 Starting

- a. Start the vehicle engine. The evaporator (interior) fans will start as soon as power is available from the vehicle electrical system.
- b. The drivers control is equipped with a single HIGH-OFF-LOW switch. The switch is placed in the desired fan speed position to start temperature control. Operation of the system is controlled automatically by an electronic thermostat which maintains the vehicles interior temperature at the desired set point.

##### 2.1.2 Stopping

#### NOTE

It is good practice to turn off the air conditioning system before stopping the vehicle engine.

Placing the A/C Mode Switch in the OFF position will stop the system operation.

#### 2.2 PRE-TRIP-INSPECTION

After starting system, allow system to stabilize for ten to fifteen minutes and check for the following:

- a. Listen for abnormal noises in compressor or fan motors.
- b. Check compressor oil level (Refer to paragraph 4.15.3).
- c. Check refrigerant charge. (Refer to paragraph 4.7.1)

#### 2.3 UNIT OPERATION

The unit has a temperature controlling Electronic Thermostat (TH), which in combination with a separate relay board, will control the vehicle's interior temperature in a clutch cycle mode.

The unit control circuits and components operate on 24 VDC supplied by the vehicle battery or alternator.

##### 2.3.1 Temperature Control

Temperature is controlled by maintaining the temperature of the air measured at the return air grille. Modes of operation include: Cooling and Vent.

##### 2.3.2 Cooling Mode

Cooling is accomplished by energizing the compressor and condenser fans and opening the liquid line solenoid valve. Once interior temperature reaches the desired set point, the thermostat will de-energize the compressor clutch and allow the system to operate in the vent mode until further cooling is required.

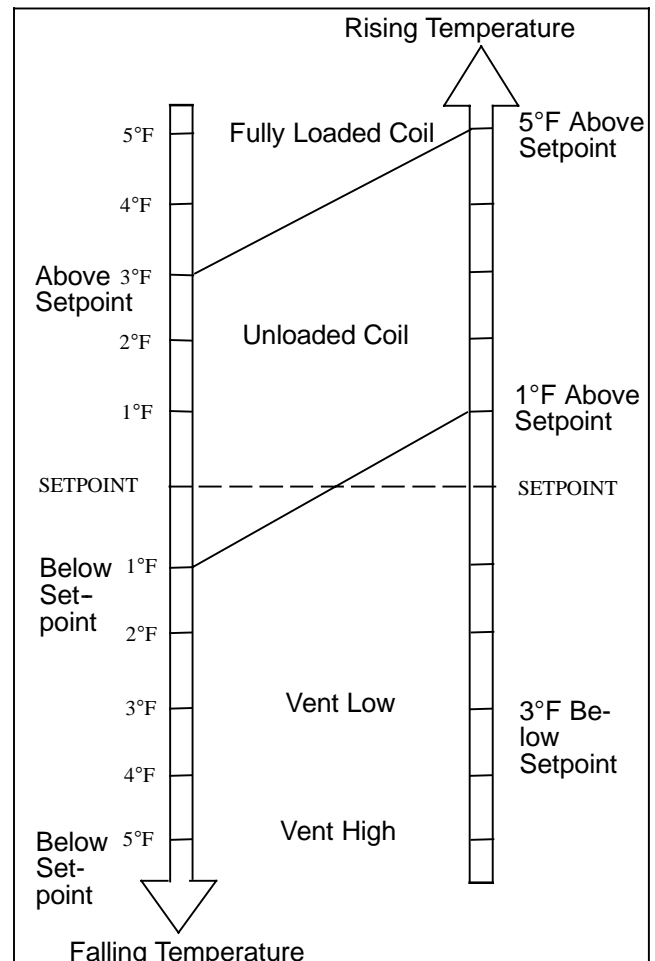

Figure 2-1 Thermostat Control Sequence

##### 2.3.3 Vent Mode

In the vent mode the evaporator fans are operated to circulate air in the bus interior.

##### 2.3.4 Compressor Unloader Control

When operating in cooling, the unloaders are used to reduce system capacity as return air temperature approaches set point. Operation of the unloaders balances system capacity with the load and thereby prevents overshoot from set point.

Relay Board mounted unloader outputs control the capacity of the compressor by energizing or de-energizing unloader solenoid valves. The model 05K has two banks of two cylinders each while the model 05G compressor has three banks of two cylinders each. Energizing a valve de-activates a bank of cylinders. The 05K right cylinder bank (looking at the pump end) and the outboard cylinder banks of the 05G are equipped with unloader valves (UV1 and, for the 05G, UV2), each controlling two cylinders; this allows the 05K to be operated with two or four cylinders and the 05G to be operated with two, four or six cylinders.



## a. Temperature Control

The unloaders are operated as follows for temperature control:

- 1 Compressor Unloader UV1. When return air temperature falls to less than 2°F (1.1°C) above set point unloader UV1 is energized. If temperature rises to greater than 3°F (1.7°C) above set point, UV1 will be de-energized to place the compressor at 100% capacity.
- 2 Compressor Unloader UV2. When return air temperature falls to less than 1°F (0.6°C) above set point unloader UV2 is energized. If temperature rises to greater than 2°F (1.1°C) above set point, UV2 will be de-energized to place the compressor at 66% capacity.

## b. Suction Pressure

The unloaders are used to control suction pressure and thereby prevent coil frosting:

- 1 Compressor Unloader UV1. When the suction pressure decreases below 26 psig (1.77 bar), unloader UV1 is energized unloading a cylinder bank (two cylinders); this output will remain energized until the pressure increases to above 34 psig (2.31 bar).
- 2 Compressor Unloader UV2. When suction pressure decreases below 23 psig (1.56 bar) unloader UV2 is energized unloading the second compressor cylinder bank; this output will remain energized until the pressure increases to above 31 psig (2.11 bar).

## c. Discharge Pressure

Discharge pressure is also controlled by the unloaders:

- 1 Compressor Unloader UV2. When the discharge pressure increases above 320 psig, unloader UV2 is energized; this output will remain energized until the pressure decreases below 250 psig.

### 2.3.5 Condenser Fan Control

The condenser fans are energized when the compressor clutch output is energized. The fans are started in low speed and will remain in low speed until the discharge pressure increases to 275 psig (R-134a). The fans will remain in high speed until discharge pressure decreases below 220 psig (R-134a).

### 2.3.6 Compressor Clutch Control

A belt driven electric clutch is employed to transmit engine power to the air conditioning compressor. De-energizing the clutch electric coil disengages the clutch and removes power from the compressor. The clutch will be engaged when in cooling and disengaged when the system is off, vent, or during high and low pressure conditions.

The clutch coil is prevented from engagement when the ambient temperature is below ambient lockout setpoint.

The clutch coil will be de-energized if the discharge pressure rises to the cutout setting of the compressor mounted high pressure switch. The clutch coil will energize when the discharge pressure falls to the reset point of the compressor mounted high pressure switch.

### 2.3.7 Liquid Line Solenoid Control

The liquid line solenoid is energized (open) when the compressor clutch is energized and de-energized (closed) when the clutch is not.

## 2.4 SEQUENCE OF OPERATION

Operation begins when the A/C mode switch (ACMS) is placed in the HIGH or LOW position. This provides:

S a signal the vehicle to apply 24V power from the vehicle alternator to the ALT+ terminal (Refer to wiring schematic, Section 5.)

S energizes the power relay (PWRR) to provide power to the speed contacts of the ACMS, power to energize the A/C relay (ACR) and power to the thermostat.

If the ACMS is in the LOW speed position, power flows through evaporator fan motor EM1, the evaporator speed relay ESR1 normally closed contacts and evaporator fan motor EM2 to energize the fans in series (low speed).

If the ACMS is in the HIGH position, ESR1 & ESR2 are both energized. With these relays energized, power flows through EM1 and the ESR1 normally open contact (now closed) direct to ground and through the ESR2 evaporator fan relay contact (now closed) and EM2 direct to ground, placing both fans in high speed.

With the evaporator fans in operation, the system is in the VENT mode.

Before the system can enter the COOL mode, the high pressure switch (HPS) and low pressure switch (LPS) must be closed. With these switches closed, the fault relay (FR) is energized. Energizing FR closes a set of normally open contacts to allow a potential circuit to the clutch (CL) and opens a set of normally closed contacts to the AC stop relays ACR1 & ACR2 and STOP light. Also, the ambient temperature must be sufficiently high enough to close the low ambient temperature thermostat (LATH).

If the thermostat is calling for cooling, power flows through the normally open ACR contacts (previously closed) and LATH (or jumper) and the following sequence occurs:

S If condenser fan speed switch CFS2 is closed, the condenser speed relay (CSR) is energized and power for the fans flows through its normally open contact (now closed) to place the fans in high speed. If condenser fan speed switch CFS2 is open, CSR is de-energized and power for the fans flows through a resistor (RES) to place the fans in low speed.

S condenser fan relay CFR1 is energized. Energizing CFR1 provides power to two condenser fan motors (CF)

S if CFS1 is closed, relays CFR2 & CFR3 are energized. Energizing CFR2 & CFR3 provides power to two (DC12174) or three (DC12175) additional condenser fan motors

S the liquid line solenoid valve (LLS) is energized

S the clutch relay (CR) is energized. Energizing relay CR closes a set of contacts to energize the compressor clutch.

The system is now operating in the COOL mode. The thermostat will open and close (energizing and de-energizing) the compressor, condenser fans and LLS as required to maintain desired temperature.

Once the temperature approaches set point, the thermostat will call for the system to unload. With the thermostat calling for unloading, unloader valve UV1 is energized. Energizing UV1 energizes one bank of compressor cylinder unloading. UV1 may also be energized if compressor suction pressure rises to the closing point of unloader pressure switch UPS1.

If discharge pressure rises to the set point of UPS3 or suction pressure falls to the set point of UPS2 unloader valve UV2 is energized. Energizing UV2 energizes one (or one additional) bank of compressor cylinder

unloading.

If either HPS or LPS open, relay FR is de-energized. De-energizing FR opens a set of contacts to de-energize the compressor clutch and closes a set of contacts to energize A/C stop relays ACSR1 & ACSR2. Energizing ACSR2 energizes the AC STOP light and sets up a holding circuit while energizing ACSR1 opens an additional set of contacts in the compressor clutch power line. The holding circuit will not be broken until power is removed by placing the ACMS or main vehicle power switch in the OFF position.

## SECTION 3

### TROUBLESHOOTING

**Table 3-1 General System Troubleshooting Procedures**

INDICATION/ TROUBLE	POSSIBLE CAUSES	REFERENCE SECTION
<b>3.1 System Will Not Cool</b>		
Compressor will not run	V-Belt loose or defective Clutch coil defective Clutch malfunction Compressor malfunction	Check Check/Replace Check/Replace See Table 1-2
Electrical malfunction	Coach power source defective Circuit Breaker/safety device open	Check/Repair Check/Reset
<b>3.2 System Runs But Has Insufficient Cooling</b>		
Compressor	V-Belt loose or defective Compressor valves defective	Check See Table 1-2
Refrigeration system	Abnormal pressures No or restricted evaporator air flow Expansion valve malfunction Restricted refrigerant flow Low refrigerant charge Service valves partially closed Safety device open Liquid solenoid valve stuck closed	3.3 3.6 3.7 4.11 4.7 Open 1.9 Check
Restricted air flow	No evaporator air flow or restriction	3.6
Heating system	Heat valve stuck open	3.8
<b>3.3 Abnormal Pressures</b>		
High discharge pressure	Refrigerant overcharge Noncondensable in system Condenser motor failure Condenser coil dirty	4.7.1 Check Check Clean
Low discharge pressure	Compressor valve(s) worn or broken Low refrigerant charge	See Table 1-2 4.7
High suction pressure	Compressor valve(s) worn or broken	See Table 1-2
Low suction pressure	Suction service valve partially closed Filter-drier inlet valve partially closed Filter-drier partially plugged Low refrigerant charge Expansion valve malfunction Restricted air flow	Open Check/Open 4.11 4.7 3.7 3.6
Suction and discharge pressures tend to equalize when system is operating	Compressor valve defective	See Table 1-2
<b>3.4 Abnormal Noise Or Vibrations</b>		
Compressor	Loose mounting hardware Worn bearings Worn or broken valves Liquid slugging Insufficient oil Clutch loose, rubbing or is defective V-belt cracked, worn or loose Dirt or debris on fan blades	Check/Tighten See Table 1-2 See Table 1-2 3.7 4.15.3 Check Check/Adjust Clean

**Table 3-1 General System Troubleshooting Procedures - Continued**

INDICATION/ TROUBLE	POSSIBLE CAUSES	REFERENCE SECTION
<b>3.4 Abnormal Noise Or Vibrations - Continued</b>		
Condenser or evaporator fans	Loose mounting hardware Defective bearings Blade interference Blade missing or broken	Check/Tighten Replace Check Check/Replace
<b>3.5 Control System Malfunction</b>		
Will not control	Sensor or Relay(s) defective	Check
<b>3.6 No Evaporator Air Flow Or Restricted Air Flow</b>		
Air flow through coil blocked	Coil frosted over Dirty coil Dirty filter	Defrost coil Clean Clean/Replace
No or partial evaporator air flow	Motor(s) defective Motor brushes defective Evaporator fan loose or defective Fan damaged Return air filter dirty Icing of coil Fan relay(s) defective Safety device open Fan rotation incorrect	Repair/Replace Replace Repair/Replace Repair/Replace Clean/Replace Clean/Defrost Check/Replace 1.9 Check
<b>3.7 Expansion Valve Malfunction</b>		
Low suction pressure with high superheat	Low refrigerant charge Wax, oil or dirt plugging valve orifice Ice formation at valve seat Power assembly failure Loss of bulb charge Broken capillary tube	4.7 Check 4.6 Replace Replace 4.13.2
Low superheat and liquid slugging in the compressor	Bulb is loose or not installed. Superheat setting too low Ice or other foreign material holding valve open	4.13.2 4.13.2
Side to side temperature difference (Warm Coil)	Wax, oil or dirt plugging valve orifice Ice formation at valve seat Power assembly failure Loss of bulb charge Broken capillary	Check 4.6 Replace Replace 4.13
<b>3.8 Heating Malfunction</b>		
Insufficient heating	Dirty or plugged heater core Coolant solenoid valve(s) malfunctioning or plugged Low coolant level Strainer(s) plugged Hand valve(s) closed Water pumps defective Auxiliary Heater malfunctioning.	Clean Check/Replace Check Clean Open Repair/Replace Repair/Replace
No Heating	Coolant solenoid valve(s) malfunctioning or plugged Controller malfunction Pump(s) malfunctioning Safety device open	Check/Replace Replace Repair/Replace 1.9
Continuous Heating	Coolant solenoid valve stuck open	Replace

## SECTION 4

### SERVICE

#### **WARNING**

Be sure to observe warnings listed in the safety summary in the front of this manual before performing maintenance on the hvac system.

#### **WARNING**

Beware of rotating fan blades and unannounced starting of fans or compressor.

#### **WARNING**

Read the entire procedure before beginning work. Park the vehicle on a level surface, with parking brake applied. Turn main electrical disconnect switch to the off position.

#### NOTE

To avoid damage to the earth's ozone layer, use a refrigerant recovery system whenever removing refrigerant. The refrigerant recovery system is available from Carrier Transicold (Carrier Transicold P/N MVSII-115 or MVSII-240). When working with refrigerants you must comply with all local government environmental laws.

### 4.1 MAINTENANCE SCHEDULE

SYSTEM		SYSTEM	REFERENCE SECTION
ON	OFF		
<b>a. Weekly Maintenance</b>			
X	X	Pre-trip Inspection - after starting Check tension and condition of V-belt	2.2 None
<b>b. Monthly Inspection</b>			
	X	Perform daily inspection	See above
	X	Check condenser, evaporator coils and return air filters for cleanliness	None
	X	Check refrigerant hoses and compressor shaft seal for leaks	4.5
X		Feel filter-drier for excessive temperature drop across drier	4.11
<b>c. Annual Inspection and Maintenance</b>			
	X	Perform weekly inspection and maintenance	See above
	X	Clean evaporator drain pans and hoses	None
	X	Check wire harnesses for chafing and loose terminals	Replace/Tighten
	X	Check fan motor bearings	None
	X	Check compressor mounting bolts for tightness	None
	X	Check fan motor brushes	None
	X	Check and drain shaft seal reservoir, (05G Manual) If Applicable	62-11052 -Sec..3

### 4.2 SUCTION AND DISCHARGE SERVICE VALVES

The suction and discharge service valves (Figure 4-1) are provided with a double seat and a gauge port, which allows servicing of the compressor and refrigerant lines.

Turning the valve stem counterclockwise (all the way out) will *backseat* the valve to open the line to the compressor and close off the gauge port. In normal operation, the valve is backseated to allow full flow

through the valve. The valve should always be backseated before removing the gauge port cap.

Turning the valve stem clockwise (all the way forward) will *frontseat* the valve to isolate the compressor line and open the gauge port.

To measure suction or discharge pressure, midseat the valve by opening the valve clockwise 1/4 to 1/2 turn. With the valve stem midway between frontseated and

backseated positions, the suction or discharge gauge port is open to both the compressor and the line.

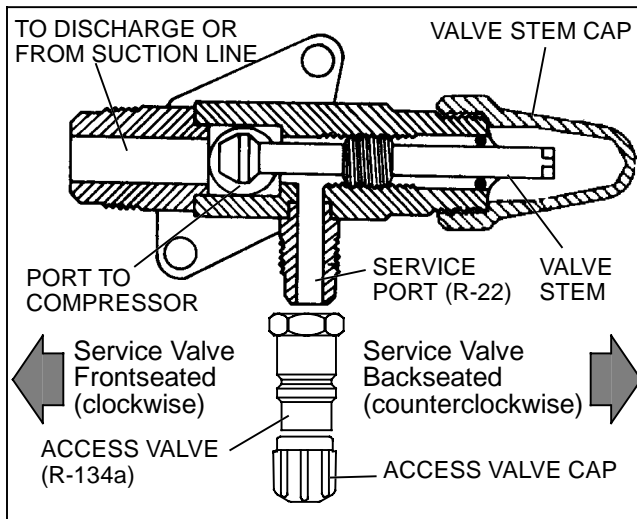

**Figure 4-1 Suction or Discharge Service Valve**

### 4.3 INSTALLING MANIFOLD GAUGE SET

A manifold gauge set (Figure 4-2) can be used to determine system operating pressures, add charge, equalize or evacuate the system.

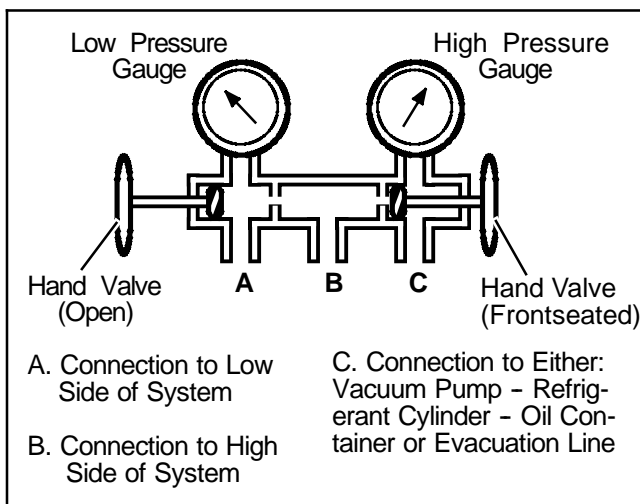

**Figure 4-2 Manifold Gauge Set**

When the suction pressure hand valve is front seated (turned all the way in), the suction (low) pressure can be read. When the discharge pressure hand valve is frontseated, discharge (high) pressure can be read. When both valves are open (turned counterclockwise), high pressure vapor will flow into the low side. When only the low pressure valve is open, the system can be charged or evacuated. To install a manifold gauge set, do the following (refer to Figure 4-4, Figure 4-5 or Figure 4-6 as applicable).

A R-134a manifold gauge/hose set with self-sealing hoses is required for service of models covered within this manual. The manifold gauge/hose set is available from Carrier Transicold. (Carrier Transicold P/N 07-00294-00, which includes items 1 through 6, Figure 4-3). To perform service using the manifold gauge/hose set, do the following:

#### a. Preparing Manifold Gauge/Hose Set For Use

1. If the manifold gauge/hose set is new or was exposed to the atmosphere it will need to be evacuated to remove contaminants and air as follows:
2. Back seat (turn counterclockwise) both field service couplers (see Figure 4-3) and midseat both hand valves.
3. Connect the yellow hose to a vacuum pump and an R-134a cylinder.
4. Evacuate to 10 inches of vacuum and then charge with R-134a to a slightly positive pressure of 1.0 psig.
5. Front seat both manifold gauge set hand valves and disconnect from cylinder. The gauge set is now ready for use.

#### b. Connecting Manifold Gauge/Hose Set

To connect the manifold gauge/hose set for reading pressures, do the following:

1. Remove service valve stem cap and check to make sure it is backseated. Remove access valve cap.
2. Connect the field service coupler (see Figure 4-3) to the access valve.
3. Turn the field service coupling knob clockwise, which will open the system to the gauge set.
4. Read system pressures.
5. Repeat the procedure to connect the other side of the gauge set.

#### c. Removing the Manifold Gauge Set

1. While the compressor is still ON, backseat the high side service valve.
2. Midseat both hand valves on the manifold gauge set and allow the pressure in the manifold gauge set to be drawn down to low side pressure. This returns any liquid that may be in the high side hose to the system.



## CAUTION

**To prevent trapping liquid refrigerant in the manifold gauge set be sure set is brought to suction pressure before disconnecting.**

3. Backseat the low side service valve. Backseat both field service couplers and frontseat both manifold set hand valves. Remove the couplers from the access valves.
4. Install both service valve stem caps and access valve caps (finger-tight only).

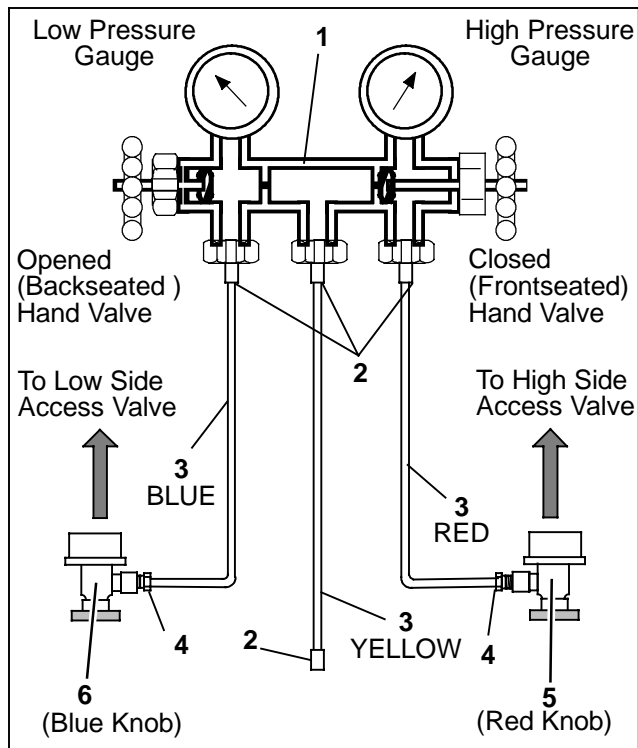

1. Manifold Gauge Set
2. Hose Fitting (0.5-16 Acme)
3. Refrigeration and/or Evacuation Hose  
(SAE J2196/R-134a)
4. Hose Fitting w/O-ring (M14 x 1.5)
5. High Side Field Service Coupler
6. Low Side Field Service Coupler

**Figure 4-3 Manifold Gauge Set (R-134a)**

#### 4.4 PUMPING THE SYSTEM DOWN OR REMOVING THE REFRIGERANT CHARGE

##### NOTE

To avoid damage to the earth's ozone layer, use a refrigerant recovery system whenever removing refrigerant.

##### 4.4.1 System Pump Down For Low Side Repair

To service or replace the filter-drier, thermostatic expansion valve, suction line, liquid line solenoid valve or evaporator coil, pump the refrigerant to the condenser and receiver as follows:

- a. Install manifold gauge set to the filter-drier inlet service valve. Refer to Figure 4-4.
- b. Frontseat the filter-drier inlet service valve by turning clockwise. Install a jumper on the compressor mounted low pressure switch.
- c. Start the system and run in cooling. Stop the unit when suction reaches a slight vacuum (1-2 "/>hg).
- d. Frontseat the compressor suction service valve to trap refrigerant in the high side of the system between the compressor suction service valve and the filter-drier inlet valve. Wait 5 minutes to verify that system remains in a vacuum. If system pressure rises above a vacuum, open the compressor suction service valve and repeat steps c and d until the system remains in a vacuum.
- e. Service or replace necessary components.
- f. Leak check connections and replace filter-drier. Refer to paragraph 4.11.
- g. Energize the Liquid Line Solenoid Valve (LSV) using an external power source (24 VDC).
- h. Using refrigerant hoses designed for vacuum service, evacuate and dehydrate the low side of the system by connecting a vacuum pump to the center connection of manifold gauge set. Evacuate system to 500 microns. Close off pump valve, isolate vacuum gauge and stop pump. Wait 5 minutes to verify that vacuum holds. The vacuum pump is available from Carrier Transicold (Carrier Transicold P/N 07-00176-11).
- i. Recharge low side with R-134a to 20 to 30 PSIG by admitting vapor from the refrigerant cylinder.
- j. Remove the low pressure switch jumper.
- k. Open service valves and check refrigerant level. Refer to paragraph 4.7.1.

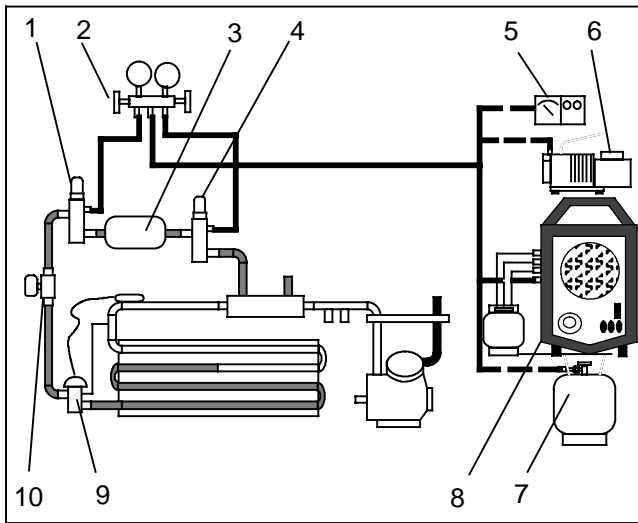

- |                                      |                                 |
|--------------------------------------|---------------------------------|
| 1. Filter-Drier Outlet Service Valve | 6. Vacuum Pump                  |
| 2. Manifold Gauge Set                | 7. Refrigerant Cylinder         |
| 3. Filter-Drier                      | 8. Reclaimer                    |
| 4. Filter-Drier Inlet Service Valve  | 9. Thermostatic Expansion Valve |
| 5. Thermistor Vacuum Gauge           | 10. Liquid Solenoid Valve       |

**Figure 4-4 Low Side Pump Down Connections**

#### 4.4.2 Refrigerant Removal From An Inoperative Compressor.

To remove the refrigerant from a compressor that is not operational, do the following:

- Attach a manifold gauge set as shown in Figure 4-5 and isolate the compressor by front seating the suction and discharge valves.
- Recover refrigerant with a refrigerant reclaimer. If the discharge service valve port is not accessible, it will be necessary to recover refrigerant through the suction service valve port only.
- Service or replace components as required and leak check the compressor.
- Using refrigerant hoses designed for vacuum service, connect a vacuum pump to center connection of manifold gauge set. Evacuate compressor to 500 microns. Close off pump valve, isolate vacuum gauge and stop pump. Wait 5 minutes to verify that vacuum holds.
- Once vacuum is maintained, recharge low side with R-134a to 20 - 30 psig by admitting vapor from the refrigerant cylinder. Backseat compressor service valves and disconnect manifold gauge set.
- Check refrigerant level. Refer to paragraph 4.7.1.

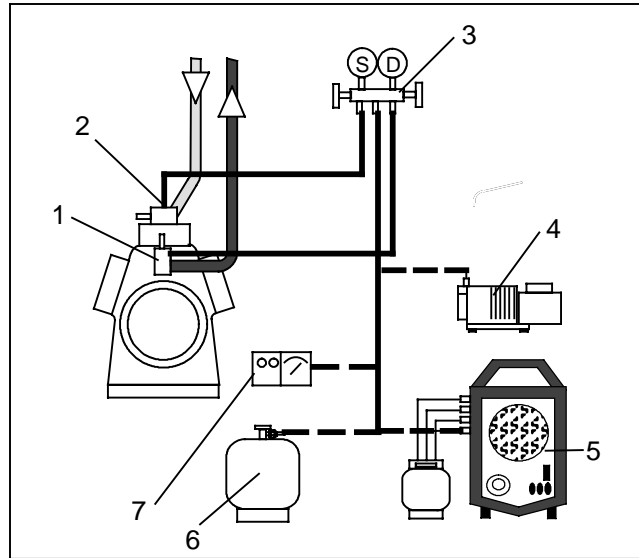

- |                                     |                            |
|-------------------------------------|----------------------------|
| 1. Discharge Service Valve and Port | 4. Vacuum Pump             |
| 2. Suction Service Valve and Port   | 5. Reclaimer               |
| 3. Manifold Gauge Set               | 6. Refrigerant Cylinder    |
|                                     | 7. Thermistor Vacuum Gauge |

**Figure 4-5 Compressor Service Connections**

#### 4.4.3 Pump Down An Operable Compressor For Repair

To service an operable compressor, pump the refrigerant into the condenser coil and receiver as follows:

- Install manifold gauge set. Refer to Figure 4-5.
- Frontseat the compressor suction service valve by turning clockwise.
- Install a jumper on the compressor mounted low pressure switch. Start the unit and run in cooling until 10 "/>hg (25.4 cm/hg) of vacuum is reached. Shut the system down and tag out system power source.
- Frontseat the compressor discharge service valve and wait 5 minutes to verify that vacuum is maintained. If the pressure rises above vacuum, open the compressor discharge service valve and repeat steps c and d until a vacuum is maintained.
- Service or replace components as required and leak check the compressor.



**To avoid the entrance of air, never evacuate an open drive compressor below 500 microns.**

- Using refrigerant hoses designed for vacuum service, connect a vacuum pump to the center connection of the manifold gauge set. Evacuate compressor to 500 microns. Close off pump valve, isolate vacuum gauge and stop pump. Wait 5 minutes to verify that vacuum holds.



- g. Once vacuum is maintained, re-connect low pressure switch. Backseat compressor service valves and disconnect manifold gauge set.
- h. Check refrigerant level. Refer to paragraph 4.7.1.

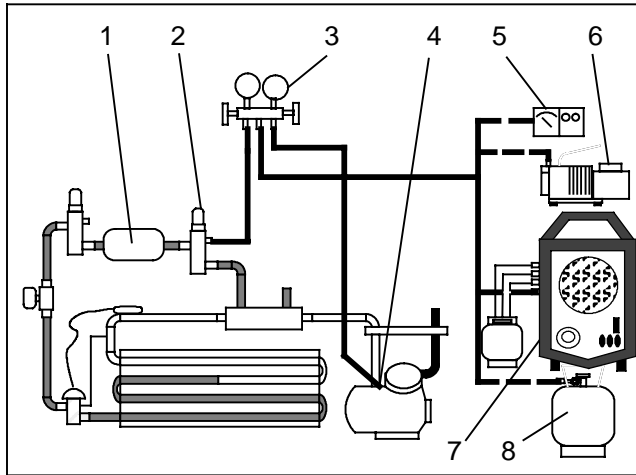

- |                                     |                            |
|-------------------------------------|----------------------------|
| 1. Filter-Drier                     | 5. Thermistor Vacuum Gauge |
| 2. Filter-Drier Inlet Service Valve | 6. Vacuum Pump             |
| 3. Manifold Gauge Set               | 7. Reclaimer               |
| 4. Suction Service Valve and Port   | 8. Refrigerant Cylinder    |

**Figure 4-6 System Charge Removal Connections**

#### 4.4.4. Removing Entire System Charge

To remove the entire refrigerant charge, do the following:

- a. Connect a manifold gauge set to the system as shown in Figure 4-6.
- b. Connect a reclaimer to the center manifold gauge set connection.
- c. Recover refrigerant in accordance with reclaimer manufacturers instructions.

#### 4.5 REFRIGERANT LEAK CHECK

A refrigerant leak check should always be performed after the system has been opened to replace or repair a component.

To check for leaks in the refrigeration system, perform the following procedure:

#### NOTE

It is emphasized that only the correct refrigerant should be used to pressurize the system. Use of any other refrigerant will contaminate the system, and require additional evacuation.

- a. Ensure the service valves are open and power the liquid line service valve from an external source.
- b. If system is without refrigerant, charge system with refrigerant vapor to build up pressure to approximately 30 PSIG (R-134a).

- c. Add sufficient nitrogen to raise system pressure to 150 to 200 psig (10.21 to 13.61 bar).
- d. Check for leaks. The recommended procedure for finding leaks in a system is with an electronic leak detector. Testing joints with soap suds is satisfactory and may be necessary under conditions when an electronic leak detector will not function correctly.
- e. Remove test gas and replace filter-drier.
- f. Evacuate and dehydrate the system. Refer to paragraph 4.6.
- g. Charge the unit. Refer to paragraph 4.7.

#### 4.6 EVACUATION AND DEHYDRATION

##### 4.6.1 General

The presence of moisture in a refrigeration system can have many undesirable effects. The most common are copper plating, acid sludge formation, "freezing-up" of metering devices by free water, and formation of acids, resulting in metal corrosion. A triple evacuation (Refer to paragraph 4.6.3) should be performed after a major system repair (compressor, evaporator, or condenser replacement). A one time evacuation (Refer to paragraph 4.6.4) should take place after a minor system repair (replacement of a solenoid valve or a filter drier).

##### 4.6.2 Preparation

#### NOTE

Using a compound gauge for determination of vacuum level is not recommended because of its inherent inaccuracy.



**Never evacuate an open drive compressor below 500 microns.**

- a. Evacuate and dehydrate only after pressure leak test. Refer to paragraph 4.5.
- b. Essential tools to properly evacuate and dehydrate any system include a good vacuum pump with a minimum of 6 cfm (10.2 m<sup>3</sup>/hr) volume displacement, (CTD P/N 07-00176-11), and a good vacuum indicator (CTD P/N 07-00414-00).
- c. Keep the ambient temperature above 60°F (15.6°C) to speed evaporation of moisture. If ambient temperature is lower than 60°F (15.6°C), ice may form before moisture removal is complete.

##### 4.6.3 Procedure for Evacuation and Dehydrating System (Triple Evacuation)

- a. Remove refrigerant using a refrigerant recovery system. Refer to paragraph 4.4.4.
- b. The recommended method is connecting lines (refrigerant hoses designed for vacuum service) as shown in Figure 4-7.
- c. Make sure vacuum pump valve is open.
- d. Start vacuum pump. Slowly open valves halfway and then open vacuum gauge valve.
- e. Evacuate unit until vacuum gauge indicates 2000 microns Hg vacuum. Close gauge valve, vacuum pump valve, and stop vacuum pump.

- f. Break the vacuum with nitrogen. Raise system pressure to approximately 2 psig.
- g. Purge the nitrogen from the system.
- h. Repeat steps d. thru g. one time.
- i. Start vacuum pump and open all valves. Dehydrate unit to 500 microns Hg vacuum.
- j. Close off pump valve, and stop pump. Wait five minutes to see if vacuum holds.
- k. Charge system. Refer to paragraph 4.7.2.

**4.6.4 Procedure for Evacuation and Dehydrating System (One Time Evacuation)**

- a. Remove refrigerant using a refrigerant recovery system. Refer to paragraph 4.4.4.
- b. The recommended method is connecting lines (refrigerant hoses designed for vacuum service) as shown in Figure 4-7.
- c. Make sure vacuum pump valve is open.
- d. Start vacuum pump. Slowly open valves halfway and then open vacuum gauge valve.
- e. Evacuate unit until vacuum gauge indicates 500 microns Hg vacuum.
- f. Close off pump valve, and stop pump. Wait five minutes to see if vacuum holds.
- g. Charge system. Refer to paragraph 4.7.2.

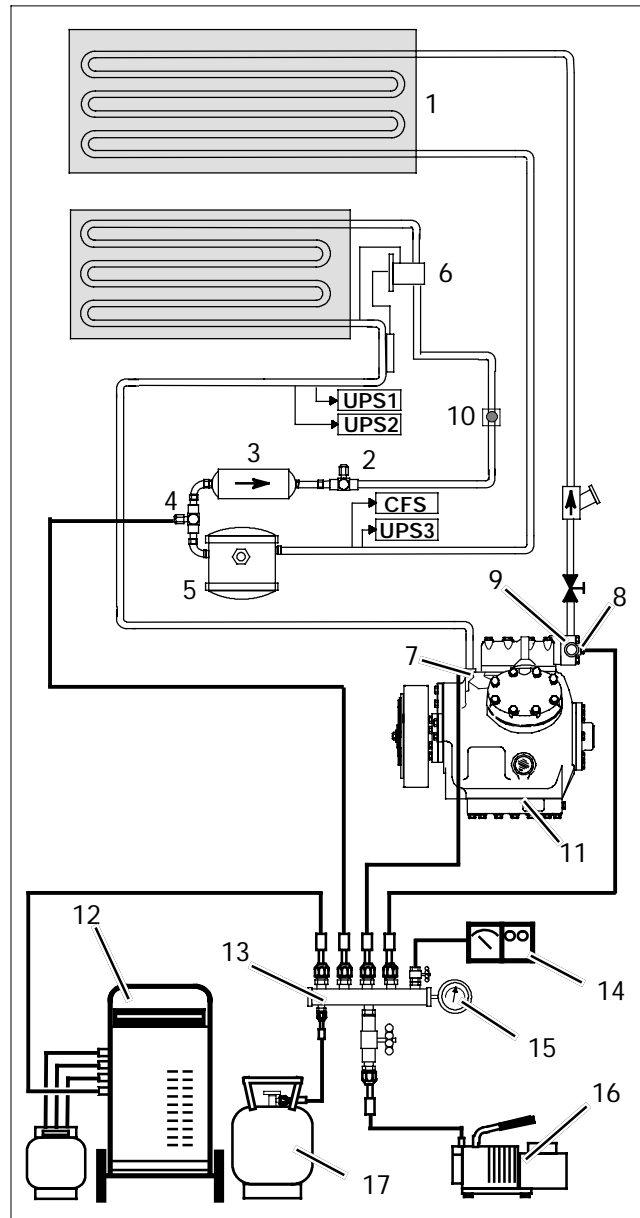

- 1 Condenser Coil
- 2 Filter-Drier Outlet Service Valve
- 3 Filter – Drier
- 4 Filter – Drier Inlet Service Valve
- 5 Receiver
- 6 Thermostatic Expansion Valve
- 7 Suction Service Valve & Service Port
- 8 Discharge Service Port
- 9 Discharge Service Valve
- 10 Liquid Line Solenoid Valve
- 11 Compressor
- 12 Reclaimer
- 13 Vacuum Manifold
- 14 Thermister Vacuum Gauge
- 15 Compound Gauge
- 16 Vacuum Pump
- 17 Refrigerant Cylinder

**Figure 4-7 Vacuum Pump Connections**

## 4.7 ADDING REFRIGERANT TO SYSTEM

### 4.7.1 Checking Refrigerant Charge

The following conditions must be met to accurately check the refrigerant charge.

- Coach engine operating at high idle.
- Compressor operating fully loaded (six cylinder) in cool mode for 15 minutes.
- Compressor discharge (head) pressure to 150 PSIG (R-134a). It may be necessary to block condenser air flow to raise discharge pressure.
- Under the above fully loaded conditions, the system is properly charged when the refrigerant liquid level is at 1/2 to 3/4 of the receiver sight glass. If it is not at the proper level, add or remove refrigerant to bring it to the proper level.

### 4.7.2 Adding Full Charge

- Install manifold gauge set at the compressor suction service valve and filter-drier inlet service valve. See figure Figure 4-6.
- Evacuate and dehydrate system. Refer to paragraph 4.6.
- Place appropriate refrigerant cylinder on scales. Prepare to charge liquid refrigerant by connect charging hose from container to center connection on gauge manifold. Purge air from hoses.
- Note weight of refrigerant and cylinder.
- Open cylinder valve, backseat discharge valve on gauge manifold and allow liquid refrigerant to flow into the high side of the system
- When correct charge has been added, close cylinder valve and frontseat manifold discharge valve. At this point, the high side of the system has been charged but the low side is still in a vacuum because the liquid line solenoid is normally closed.
- Prepare the cylinder as required to allow vapor charging. Backseat the manifold suction valve and charge vapor to build 30 PSIG (R-134a) pressure on the manifold suction gauge. Close cylinder valve and frontseat suction manifold set.
- Check charge level in accordance with the procedures of paragraph 4.7.1.

### 4.7.3 Adding Partial Charge

- Install manifold gauge set at the compressor suction service valve and filter-drier inlet service valve. See Figure 4-6.
- Place appropriate refrigerant cylinder on scale. Prepare to charge vapor refrigerant by connecting charging hose from container to center connection on gauge manifold. Purge air from hoses.

- Run the unit in the cool mode as described in section 4.7.1. With the suction service valve midseated, open the refrigerant cylinder valve and add vapor charge until the refrigerant level appears in the liquid line sight glass. Under the above conditions, the system is properly charged when the refrigerant liquid level is at 1/2 sight glass. If it is not at the proper level, add or remove refrigerant to bring it to the proper level.
- Backseat the suction service valve. Close the vapor valve on the refrigerant drum and note weight. Remove the manifold gauge set and replace all valve caps.

## 4.8 CHECKING FOR NONCONDENSIBLES

To check for noncondensibles, proceed as follows:

- Stabilize system to equalize pressure between the suction and discharge side of the system.
- Check temperature at the condenser and receiver.
- Check pressure at the filter-drier inlet service valve.
- Check saturation pressure as it corresponds to the condenser/receiver temperature using the Temperature-Pressure Chart, Table 4-2.
- If gauge reading is 3 psig (0.20 bar) or more than the saturation pressure in step d, noncondensibles are present.
- Remove refrigerant using a refrigerant recovery system.
- Evacuate and dehydrate the system. Refer to paragraph 4.6.3.
- Charge the unit. Refer to paragraph 4.7.2.

## 4.9 CHECKING AND REPLACING HIGH OR LOW PRESSURE SWITCH



**Do not use a nitrogen cylinder without a pressure regulator**



**Do not use oxygen in or near a refrigeration system as an explosion may occur.**

- Disconnect wiring and remove switch from unit. All units are equipped with a schrader valve at the pressure switch connections.
- Connect switch to a cylinder of dry nitrogen. See Figure 4-8.

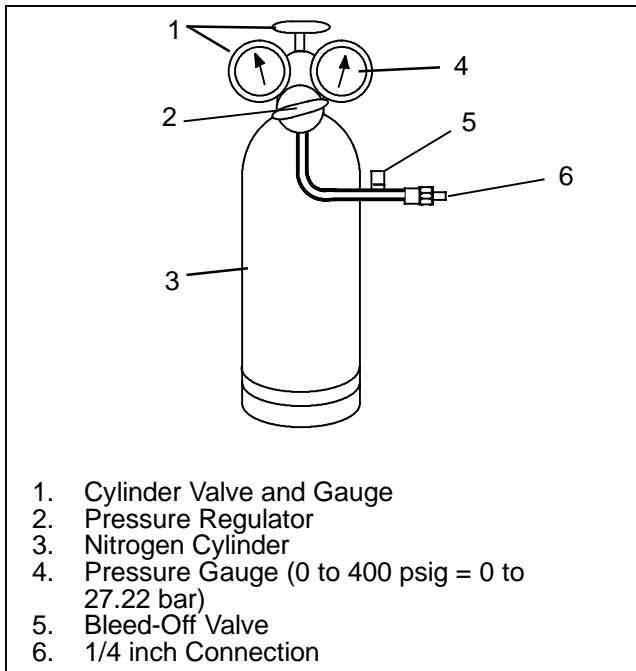

1. Cylinder Valve and Gauge
2. Pressure Regulator
3. Nitrogen Cylinder
4. Pressure Gauge (0 to 400 psig = 0 to 27.22 bar)
5. Bleed-Off Valve
6. 1/4 inch Connection

**Figure 4-8 Checking High Pressure Switch**

- c. Connect an ohmmeter across switch terminals.
- d. Set nitrogen pressure regulator higher than the upper switch setting. (refer to paragraph 1.4).
- e. For a high pressure switch, close cylinder valve and open bleed-off valve. Open cylinder valve and slowly close bleed-off valve. The switch should open, (no continuity) within required cut out tolerance. Close cylinder valve and release pressure through the bleed-off valve. As pressure drops, switch should close, (continuity) within required cut in tolerance.
- f. For a low pressure switch, close cylinder valve and bleed-off valve. Open cylinder valve to bring pressure above the cutout setting. Close the cylinder valve and slowly open bleed-off valve. The switch should open, (no continuity) within required cut out tolerance. Open cylinder valve and increase pressure by closing the bleed-off valve. As pressure increases, switch should close, (continuity) within required cut in tolerance.
- g. Replace or re-install switch (as required) and reconnect wiring.

#### 4.10 REMOVING TOP COVER (KR-4 CONDENSER)

The KR-4 condenser cover assembly is of one piece construction. To remove the cover from the condenser assembly do the following:

- a. Twist all (10) of the 1/4 Turn cam locks counterclockwise (see Figure 4-9).
- b. Using two people, grasp the condenser cover section under the bottom edge and lift up evenly from both sides.

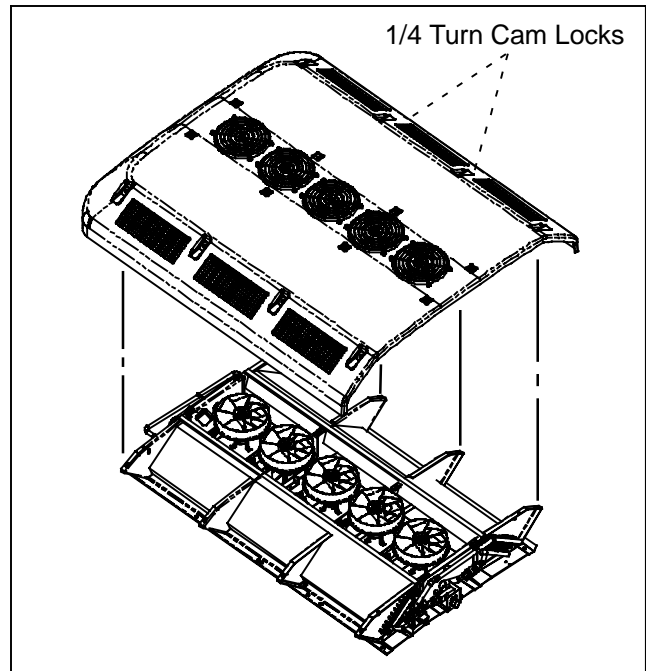
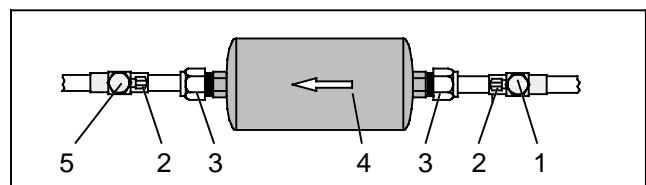

**Figure 4-9 Condenser Cover Removal**

#### 4.11 FILTER-DRIER

##### 4.11.1 To Check Filter-Drier

The filter-drier (see Figure 4-10) must be changed if the drier is partially restricted or service has been performed on the refrigerant system. Check for a restriction by feeling the inlet and outlet lines of the filter-drier. If the outlet side feels cooler than the inlet side, then the filter-drier should be changed



- |                                     |                                      |
|-------------------------------------|--------------------------------------|
| 1. Filter-Drier Inlet Service Valve | 4. Filter-Drier                      |
| 2. Valve Service Port               | 5. Filter-Drier Outlet Service Valve |
| 3. Flare Nut                        |                                      |

**Figure 4-10 Filter-Drier Removal**

##### 4.11.2 To Replace Filter-Drier

- a. Perform a low side pump down. Refer to paragraph 4.4.1, (steps a. to c.)
- b. Turn the driver's A/C switch to "OFF" position.
- c. Frontseat the filter-drier outlet service valve and place a new filter-drier near the unit for immediate installation.
- d. Remove two screws securing the filter-drier clamp. Remove the filter-drier clamp.



## WARNING

The filter-drier may contain liquid refrigerant. Slowly loosen the flare nuts to avoid refrigerant contact with exposed skin or eyes.

- Using two open end wrenches, slowly crack open the flare nuts on each side of the filter-drier. Remove the filter-drier.
- Remove seal caps from the new filter-drier. Apply a light coat of compressor oil to the flares.
- Assemble the new filter-drier to lines ensuring that the arrow on the body of the filter-drier points in the direction of the refrigerant flow (refrigerant flows from the receiver to the evaporator). Finger tighten flare nuts.
- Tighten filter-drier flare nuts using two open end wrenches.
- Evacuate the filter-drier and lines by connecting a vacuum pump as shown in Figure 4-4. Evacuate to 500 microns.
- Backseat (fully close) both service valve ports and replace valve caps.
- Test filter-drier for leaks.
- Check refrigerant level.

### 4.12 SERVICING THE LIQUID LINE SOLENOID VALVE

The Liquid line solenoid valve (Figure 4-11) requires no maintenance unless a malfunction to the internal parts or coil occurs. This may be caused by foreign material such as: dirt, scale, or sludge in the refrigeration system, or improper voltage to the coil.

There are only three possible valve malfunctions: coil burnout, failure to open, or failure to close.

#### Coil burnout may be caused by the following:

- Improper voltage.
- Continuous over-voltage, more than 10% or under-voltage of more than 15%.
- Incomplete magnet circuit due to the omission of the coil housing or plunger.
- Mechanical interface with movement of plunger which may be caused by a deformed enclosing tube.

#### Failure to open may be caused by the following:

- Coil burned out or an open circuit to coil connections.
- Improper voltage.
- Defective plunger or deformed valve body assembly.

#### Failure to close may be caused by the following:

- Defective plunger or deformed valve body assembly.
- Foreign material in the valve.

#### 4.12.1 Coil Replacement

- It is not necessary to remove the refrigerant charge from the system.
- Place main battery disconnect switch in OFF position and lock.
- Disconnect wire leads to coil.

- Remove coil retaining clip and nameplate.
- Lift burned-out coil from enclosing tube and replace.
- Connect wire leads and test operation

#### 4.12.2 Internal Part Replacement

- Perform a low side pump down. Refer to paragraph 4.4.1 .
- Carefully loosen enclosing tube assembly and ensure no pressure remains within the valve. Disassemble valve and replace defective parts.
- Assemble valve and leak check.
- Evacuate low side and re-open system.

#### 4.12.3 Replace Entire Valve

- Perform a low side pump down. Refer to paragraph 4.4.1. Remove coil and plunger assembly and un-braze valve from lines.
- Remove valve assembly from bracket.
- Disassemble new valve, to protect internal parts, and solder to lines.
- Assemble and leak check valve.
- Evacuate low side and re-open system.
- Connect wire leads and test operation.

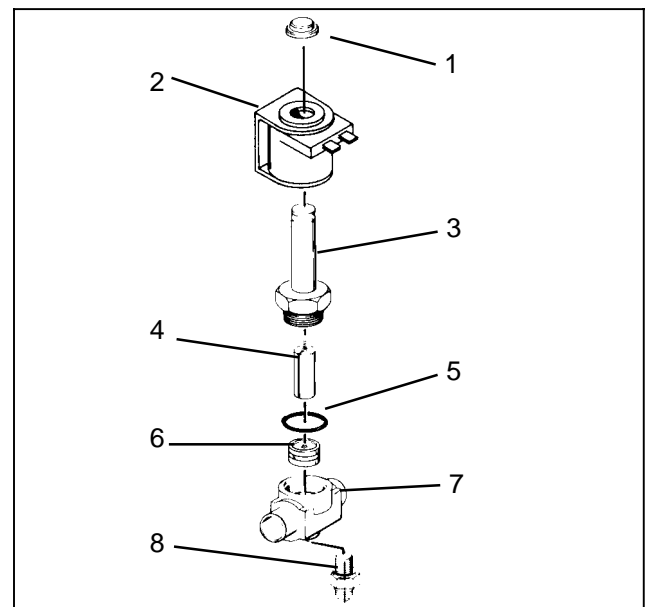

- |                            |                    |
|----------------------------|--------------------|
| 1. Snap Cap                | 5. Gasket          |
| 2. Coil Assembly           | 6. Piston Assembly |
| 3. Enclosing Tube Assembly | 7. Body            |
| 4. Plunger Assembly        | 8. Bracket Adapter |

Figure 4-11 Liquid Line Solenoid Valve

### 4.13 THERMOSTATIC EXPANSION VALVE

The thermostatic expansion valve (Figure 4-11) is an automatic device which maintains constant superheat of the refrigerant gas leaving the evaporator regardless of suction pressure. The valve functions are: (a) automatic control of refrigerant flow to match the evaporator load and (b) prevention of liquid refrigerant entering the compressor. Unless the valve is defective, it seldom requires any maintenance.

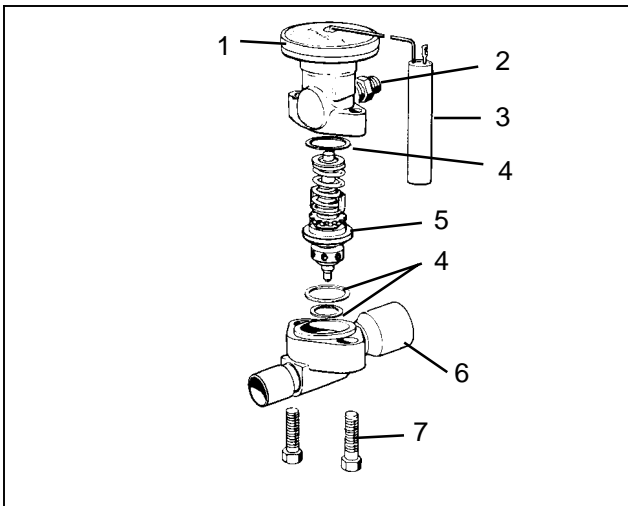

- |                         |                  |
|-------------------------|------------------|
| 1. Power Head Assembly  | 4. Gasket        |
| 2. Equalizer Connection | 5. Cage Assembly |
| 3. Bulb                 | 6. Body Flange   |
|                         | 7. Cap screw     |

**Figure 4-12 Thermostatic Expansion Valve**

#### 4.13.1 Valve Replacement

- Pump down low side of the unit. Refer to paragraph 4.4.1.
- Remove insulation from expansion valve and bulb. See Figure 4-12 and Figure 4-13.
- Loosen retaining straps holding bulb to suction line and detach bulb from the suction line.
- Loosen flare nuts on equalizer line and disconnect equalizer line from the expansion valve.
- Remove capscrews and lift off power head and cage assemblies and gaskets.
- Check, clean and remove any foreign material from the valve body, valve seat and mating surfaces. If required, replace valve body.

#### NOTE

R-134a valves are non-adjustable.

- Using new gaskets, install new cage and power head assemblies.
- Fasten equalizer line to the expansion valve.
- Leak check the new valve and evacuate and dehydrate low side. Refer to paragraph 4.4.1.
- The thermal bulb is installed below the center of the suction line (four or eight o'clock position). This area must be clean to ensure positive bulb contact. Strap thermal bulb to suction line. Ensure that retaining straps are tight and renew insulation.
- If required, add vapor refrigerant to bring low side pressure to 20 to 30 PSIG (R-134a). Open filter-drier inlet service valve and compressor service valves.
- Run the coach for approximately 30 minutes on fast idle.
- Check refrigerant level. Refer to paragraph 4.7.1.
- Check superheat. Refer to paragraph 4.13.2.

#### 4.13.2 Superheat Measurement

#### NOTE

All readings must be taken from the TXV bulb location and out of the direct air stream.

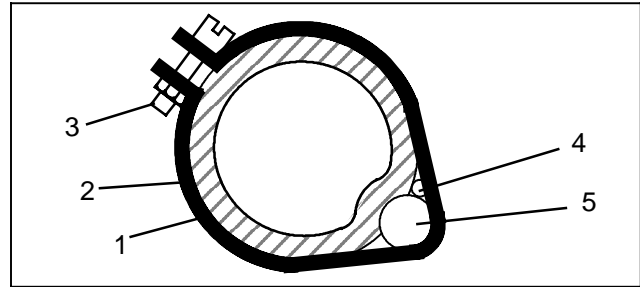

- |                                |   |
|--------------------------------|---|
| 1. Suction Line (section view) | 4. Thermocouple                             |
| 2. TXV Bulb Clamp              | 5. TXV Bulb (Shown in the 4'clock position) |
| 3. Nut & Bolt (clamp)          |   |

**Figure 4-13 Thermostatic Expansion Valve Bulb and Thermocouple**

- Remove Presstite insulation from expansion valve bulb and suction line.
- Loosen one TXV bulb clamp and make sure area under clamp is clean.
- Place temperature thermocouple in contact with the suction tube and parallel to the TXV bulb, and then secure loosened clamp making sure both bulb and thermocouple are firmly secured to suction line. See Figure 4-13. Reinstall insulation around the bulb.
- Connect an accurate low pressure gauge to the low pressure port (Figure 1-5).
- Start bus and run on fast idle until unit has stabilized, about 20 to 30 minutes.

#### NOTE

When conducting this test, the suction pressure must be at least 6 psig (0.41 bar) below the expansion valve maximum operating pressure (MOP). Refer to paragraph NO TAG for MOP.

- From the temperature/pressure chart (Table 4-2), determine the saturation temperature corresponding to the evaporator outlet pressure.
- Note the temperature of the suction gas at the expansion valve bulb. Subtract the saturation temperature from this temperature. The difference is the superheat of the suction gas.
- The superheat may cycle from a low to high reading. Monitor the superheat taking readings every 3-5 minutes for a total of 5-6 readings. Calculate the superheats, add the readings and divide by the number of readings taken to determine average superheat. Refer to paragraph NO TAG for superheat setting.
- If superheat is not within tolerance, replace the valve.

#### 4.14 REPLACING RETURN AIR FILTERS

The return air filters are located behind the return air grill, inside the vehicle.

The filters should be checked for cleanliness periodically depending on operating conditions. A dirty

filter will restrict air flow over the evaporator coil which may cause insufficient cooling or heating and possible frost buildup on the coil. To remove the filters, do the following.

- a. Place main battery disconnect switch in OFF position and lock.
- b. Remove the return air grille.
- c. Loosen filter retaining hardware and remove the filter from the grille.
- d. Reverse procedure to install new filters.

#### 4.15 COMPRESSOR MAINTENANCE

##### 4.15.1 Removing the Compressor

If compressor is inoperative and the unit still has refrigerant pressure, isolate the compressor and remove the refrigerant. Refer to paragraph 4.4.2. If compressor is operative, perform a pump down. Refer to paragraph 4.4.3.

- a. Place main battery disconnect switch in OFF position and lock.
- b. Tag and disconnect wiring to the high pressure and low pressure switch, unloaders and clutch.
- c. Remove tension on drive belts, remove drive belts.
- d. Loosen bolts at suction and discharge service valve flanges and break seal to be sure pressure is released. Remove bolts.
- e. Remove four bolts holding compressor to base
- f. Attach sling or other device to the compressor and remove compressor from the coach through the rear access door.

#### NOTES

- 1 Service replacement compressors are sold without service valves. Valve pads are installed in their place. The optional unloaders are not supplied, as the cylinder heads are shipped with plugs. Customer should retain the original unloader valves for use on the replacement compressor.
- 2 The piston plug that is removed from the replacement compressor head must be installed in the failed compressor if returning for warranty or core credit.
- 3 Do not interchange allen-head capscrews that mount the piston plug and unloader, they are not interchangeable.
- 4 Check oil level in service replacement compressor. Refer to paragraphs NO TAG and 4.15.3.

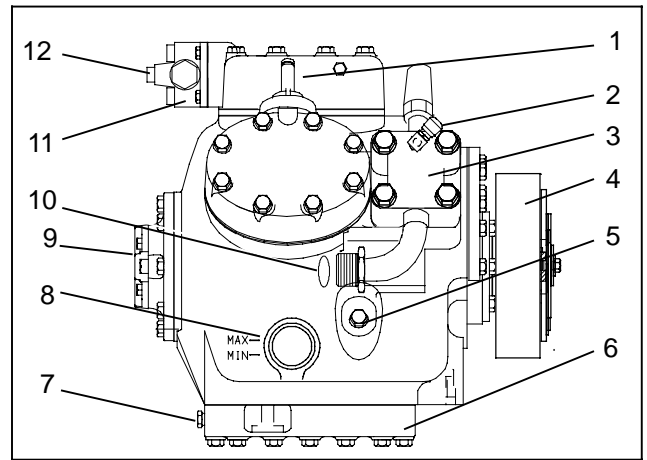

- |  |                             |
|--|-----------------------------|
| 1. Electric Unloader Valve             | 6. Bottom Plate             |
| 2. Suction Service Valve Charging Port | 7. Oil Drain Plug           |
| 3. Suction Service Valve               | 8. Oil Level Sight Glass    |
| 4. Clutch                              | 9. Oil Pump                 |
| 5. Oil Fill Plug                       | 10. O-ring                  |
|  | 11. Discharge Service Valve |
|  | 12. Service Port            |

**Figure 4-14 Compressor**

- g. Remove the three socket head capscrews from the cylinder head(s) that have unloader valves installed. See Figure 4-15. Remove the unloader valve and bypass piston assembly, keeping the same capscrews with the assembly. The original unloader valve must be transferred to the replacement compressor. The plug arrangement removed from the replacement is installed in the original compressor as a seal. If piston is stuck, it may be extracted by threading a socket head capscrew into top of piston. A small Teflon seat ring at the bottom of the bypass piston plug must be removed.

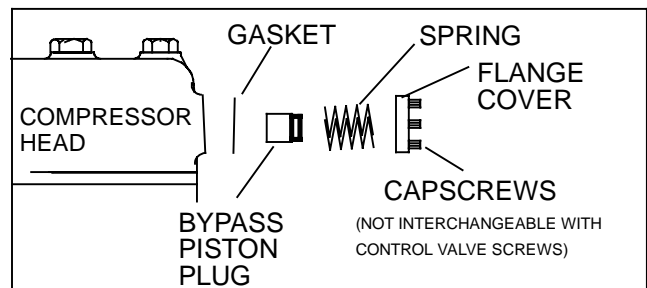

**Figure 4-15 Removing Bypass Piston Plug**

- h. Remove the pressure switches and install on replacement compressor after checking switch operation. Refer to paragraph 4.9.
- i. Remove clutch assemble and retain original clutch key. Install on replacement compressor.
- j. Install compressor in unit by performing the removal steps in reverse. It is recommended that new lock-nuts be used when replacing compressor. Install new gaskets on service valves and tighten bolts uniformly (55 to 80 ft-lbs suction and 20 to 30 ft-lbs discharge service valves).
- k. Leak check connections and replace filter-drier. Refer to paragraph 4.11.
- l. Using refrigerant hoses designed for vacuum service, connect a vacuum pump (see Figure 4-5) and evacu-

ate compressor to 500 microns. Front seat both manifold valves to isolate the pump.

- m. Open compressor service valves.
- n. Start unit and check refrigerant level. Refer to paragraph 4.7.1.
- o. Check compressor oil level. Refer to paragraph 4.15.3. Add or remove oil if necessary.
- p. Check compressor unloader operation. Refer to paragraph 4.15.4
- q. Backseat compressor service valves.
- r. Remove manifold gauge set. Refer to paragraph NO TAG.

#### 4.15.2 Transferring Compressor Clutch

To remove a clutch (see Figure 4-16) from a compressor and install on a replacement compressor, do the following:

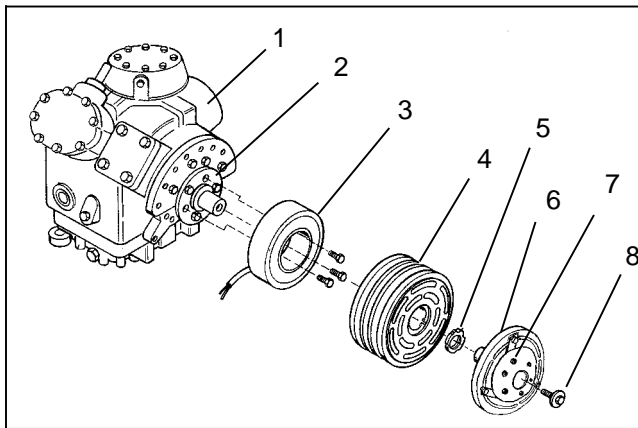

- |               |  |
|---------------|--|
| 1. Compressor | 6. Armature                                      |
| 2. Seal Cover | 7. Spacer Nuts                                   |
| 3. Coil       | 8. Retaining Capscrew,<br>Lockwasher, 3/8 Washer |
| 4. Rotor      |  |
| 5. Rotor Nut  |  |

**Figure 4-16 Compressor Clutch**

- a. Place main battery disconnect switch in OFF position and lock.
- b. Tag and disconnect wiring to the clutch.
- c. Remove tension on drive belts, remove drive belts.
- d. Remove the armature as a complete assembly by removing the retaining capscrew, lockwasher, and special 3/8 washer from the compressor crankshaft. Use special tool (CTD P/N 07-00240-01) to prevent crankshaft rotation.
- e. Install a 7/8-14 x 4" (CTD P/N 07-00381-00) capscrew into the center hole of the armature assembly and use it as a jacking bolt to remove the armature. Use tool (CTD P/N 07-00240-01) as in step a. to prevent crankshaft rotation.
- f. Using special tool (CTD P/N 07-00242-01), remove the rotor nut and rotor. Retain original key.
- g. Noting the position of the wire, remove the three bolts holding the coil to the compressor.
- h. Remove every other bolt from the seal cover of the new compressor in the same manner as the original compressor. Mount the coil assembly with the wire in

the same orientation as it was mounted on the original compressor. Tighten the mounting bolts to 45-50 ft/lbs (5.53-6.92 mkg).

- i. Mount the rotor on the shaft. Seat the rotor to the hub, using the rotor nut. Be sure pulley turns freely without binding. Tighten rotor nut by first noting torque necessary to start the nut on the hub and then adding 50 ft/lbs of torque.
- j. Install armature on shaft using original key and tighten mounting bolt to 20 ft/lbs (2.8 mkg).
- k. Perform a check of the air gap between the inside face of the armature and the mating face of the rotor. The air gap should be measured with a minimum of 50 psig (3.4 bar) in the crankcase. A preliminary check may be performed before the crankcase is pressurized but a final check must be performed before the clutch is operated. The gap should be between 0.030 and 0.060 inch (7.62 to 15.24 mm). If required, remove the six armature spacer nuts and spacer. Add or remove shims to adjust gap. Reinstall spacer nuts and tighten to 7-8 ft/lbs (1.0 to 1.1 mkg).

l. Reconnect wiring and test clutch operation.

#### 4.15.3 Compressor Oil Level

To check, and correct (if required) the compressor oil level, do the following:

- a. Operate the coach for at least one-half hour at fast idle speed, with the temperature controls at the coolest setting, and the compressor fully loaded. It may be necessary to pre-heat the coach and/or operate the system in the reheat mode to keep the compressor fully loaded throughout this procedure
- b. Ensure the system is fully charged (refer to paragraph 4.7.1) and the compressor crankcase is warm to the touch after fifteen minutes of operation.
- c. Shut off the system and immediately record the oil level in the compressor sight glass. See Figure 4-14. If the compressor is not level, an average between the sight glass levels will have to be made to determine level.
- d. The correct oil level for this application should be between the bottom and 1/2 of the oil level sightglass. See Figure 4-14. If the oil level is correct, release the coach into service. If the level is above the 1/2 sightglass maximum, proceed to step e. If the level is below the 1/2 sightglass maximum proceed to step f.
- e. To remove oil and bring the level to the 1/2 sightglass maximum, do the following:
  - 1. With the system off, connect a manifold gauge set to the compressor suction and discharge service valves. Front seat the service valves to isolate the compressor from the system (See Figure 4-5) and reclaim the refrigerant to below atmospheric pressure. Shut off the reclaim and verify the pressure does not rise. If the pressure rises, continue reclaiming until the pressure remains below atmospheric.





## WARNING

**Extreme care must be taken to ensure that all the refrigerant has been removed from the compressor crankcase or the resultant pressure will forcibly discharge compressor oil.**

2. Drain or pump out compressor oil until the level is brought to the proper level.
3. Evacuate the compressor to 500 microns. Backseat the compressor service valves and repeat the oil level check procedure.
- f. To add oil to the compressor, do the following:
  1. With the system off, connect a manifold gauge set to the compressor suction and discharge service valves. Front seat both service valves to isolate the compressor from the system (See Figure 4-5) and reclaim the refrigerant to below atmospheric pressure. Shut off the reclaiming and verify the pressure does not rise. If the pressure rises, continue reclaiming until the pressure remains below atmospheric.
  2. Add oil to compressor crankcase slowly, through the oil fill plug opening (see Figure 4-14) to bring level to mid range of allowed levels.
  3. Evacuate compressor to 500 microns. Backseat compressor suction and discharge valves, start system and recheck oil level.
  4. Remove manifold gauge set.

### 4.15.4 Compressor Electric Unloader Operation

To check unloader operation do the following:

- a. Install a manifold gauge set (Refer to Figure 4-6).
- b. Start the unit and allow it to stabilize in High Speed Cool.
- c. Insure that the unloaders are de-energized. Compressor is fully loaded, 6 cylinder operation.
- d. Slowly front-seat the suction service valve. The suction pressure will begin to fall.
- e. Watch the suction gauge on the manifold gauge set. When the suction pressure gauge "jumps" (3 to 5 psi- 0.2 to 0.4 bar) note the pressure at which the gauge jumped in the chart below. Unloader solenoid coil #1 has been energized and the compressor is now in 4 cylinder operation.
- f. Continue to slowly front-seat the suction service valve and watch the suction gauge. When the suction pressure gauge "jumps" (3 to 5 psi- 0.2 to 0.4 bar) note the pressure at which the gauge jumped in the chart below. Unloader solenoid coil #2 has been energized and the compressor is now in 2 cylinder operation.
- g. Slowly back-seat the suction service valve. The suction pressure will begin to rise.
- h. Watch the suction gauge on the manifold gauge set. When the suction pressure gauge "jumps" (3 to 5 psi- 0.2 to 0.4 bar) note the pressure at which the gauge jumped in the chart below. Unloader solenoid coil #2

has been de-energized and the compressor is now in 4 cylinder operation.

- i. Continue to slowly back-seat the suction service valve and watch the suction gauge. When the suction pressure gauge "jumps" (3 to 5 psi- 0.2 to 0.4 bar) note the pressure at which the gauge jumped in the chart below. Unloader solenoid coil #1 has been de-energized and the compressor is now in 6 cylinder operation.
- j. Compare these values to the one in your service manual (Table 1-3).

PRESSURE READING	COIL ENERGIZED UNLOADED	COIL DE-ENERGIZED LOADED
UNLOADER #1		
UNLOADER #2		

### Approximate Unloader Coil Resistance:

12VDC Coil = 10.2 Ohms

24VDC Coil = 40.0 Ohms

### 4.16 TEMPERATURE SENSOR CHECKOUT

- a. An accurate ohmmeter must be used to check resistance values shown in Table 4-1.
- b. Due to variations and inaccuracies in ohmmeters, thermometers or other test equipment, a reading within two percent of the chart value would be considered acceptable. If a sensor is bad, the resistance value would usually be much higher or lower than the value given in Table 4-1.
- c. At least one sensor lead must be disconnected from the controller before any reading can be taken. Not doing so will result in a false reading. Two preferred methods of determining the actual test temperature at the sensor are an ice bath at 32°F (0°C) and/or a calibrated digital temperature meter.

**Table 4-1 Temperature Sensor Resistance**

Temperature		Resistance In Ohms
°F	°C	
14	-10	55,304
23	- 5	42,316
32	0	32,650
41	5	25,394
50	10	19,903
59	15	15,713
68	20	12,493
77	25	10,000
86	30	8,056
95	35	6,531
104	40	5,325
113	45	4,367
122	50	3,601
131	55	2,986
140	60	2,488

#### 4.17 REPLACING SENSORS

- a. Place main battery disconnect switch in OFF position and lock.
- b. Tag and disconnect wiring from defective sensor.
- c. Remove and replace defective sensor. Sensor connections are fitted with Schreader valves to facilitate replacement.
- d. Connect wiring to replacement sensor.
- e. Checkout replacement sensor. Refer to section 4.16.
- f. Repair or replace any defective component(s), as required.

#### 4.18 ELECTRIC COMPRESSOR UNLOADERS

The electric unloaders are activated by an electromagnetic coil, which is energized by a pressure switch monitoring refrigerant pressure. (See Figure 4-10.)

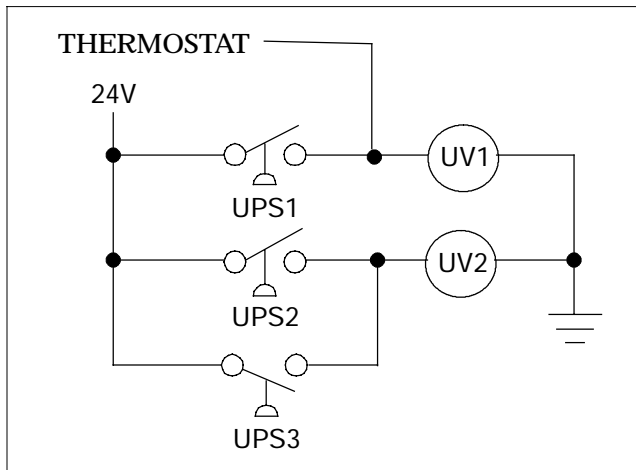

Figure 4-10. Electric Unloader Schematic

Pressure switches UPS1 and UPS2 are installed in the suction return line to the compressor. Each switch monitors suction pressure and operates one unloader by controlling the voltage applied to the unloader coil. When suction pressure falls to the setpoint of the pressure switch, the switch contacts close applying control voltage to energize the unloader coil, which unloads two of the compressor cylinders each.

Pressure switch UPS3 is installed in the liquid line to the receiver. The switch monitors refrigerant liquid line pressure and operates unloader coil UL2 by controlling voltage applied to the coil. When refrigerant liquid pressure rises to the setpoint of the pressure switch, the switch contacts close applying control voltage to energize unloader coil UL2, which unloads one of the compressor cylinder banks.

Pressure switch (UPS1, UPS2 and UPS3) settings are given in Table 1-3.

**Table 4-2 R-134a Temperature - Pressure Chart**

Temperature		Vacuum		
°F	°C	"/hg	Kg/cm <sup>2</sup>	Bar
-40	-40	14.6	37.08	0.49
.35	.37	12.3	31.25	0.42
-30	-34	9.7	24.64	0.33
-25	-32	6.7	17.00	0.23
-20	-29	3.5	8.89	0.12
-18	-28	2.1	5.33	0.07
-16	-27	0.6	1.52	0.02

Temperature		Pressure		
°F	°C	Psig	Kg/cm <sup>2</sup>	Bar
-14	-26	0.4	0.03	0.03
-12	-24	1.2	0.08	0.08
-10	-23	2.0	0.14	0.14
-8	-22	2.9	0.20	0.20
-6	-21	3.7	0.26	0.26
-4	-20	4.6	0.32	0.32
-2	-19	5.6	0.39	0.39
0	-18	6.5	0.46	0.45
2	-17	7.6	0.53	0.52
4	-16	8.6	0.60	0.59
6	-14	9.7	0.68	0.67
8	-13	10.8	0.76	0.74
10	-12	12.0	0.84	0.83
12	-11	13.2	0.93	0.91
14	-10	14.5	1.02	1.00
16	-9	15.8	1.11	1.09
18	-8	17.1	1.20	1.18
20	-7	18.5	1.30	1.28
22	-6	19.9	1.40	1.37
24	-4	21.4	1.50	1.48
26	-3	22.9	1.61	1.58

Temperature		Pressure		
°F	°C	Psig	Kg/cm <sup>2</sup>	Bar
28	-2	24.5	1.72	1.69
30	-1	26.1	1.84	1.80
32	0	27.8	1.95	1.92
34	1	29.6	2.08	2.04
36	2	31.3	2.20	2.16
38	3	33.2	2.33	2.29
40	4	35.1	2.47	2.42
45	7	40.1	2.82	2.76
50	10	45.5	3.20	3.14
55	13	51.2	3.60	3.53
60	16	57.4	4.04	3.96
65	18	64.1	4.51	4.42
70	21	71.1	5.00	4.90
75	24	78.7	5.53	5.43
80	27	86.7	6.10	5.98
85	29	95.3	6.70	6.57
90	32	104.3	7.33	7.19
95	35	114.0	8.01	7.86
100	38	124.2	8.73	8.56
105	41	135.0	9.49	9.31
110	43	146.4	10.29	10.09
115	46	158.4	11.14	10.92
120	49	171.2	12.04	11.80
125	52	184.6	12.98	12.73
130	54	198.7	13.97	13.70
135	57	213.6	15.02	14.73
140	60	229.2	16.11	15.80
145	63	245.6	17.27	16.93
150	66	262.9	18.48	18.13
155	68	281.1	19.76	19.37

# SECTION 5 ELECTRICAL





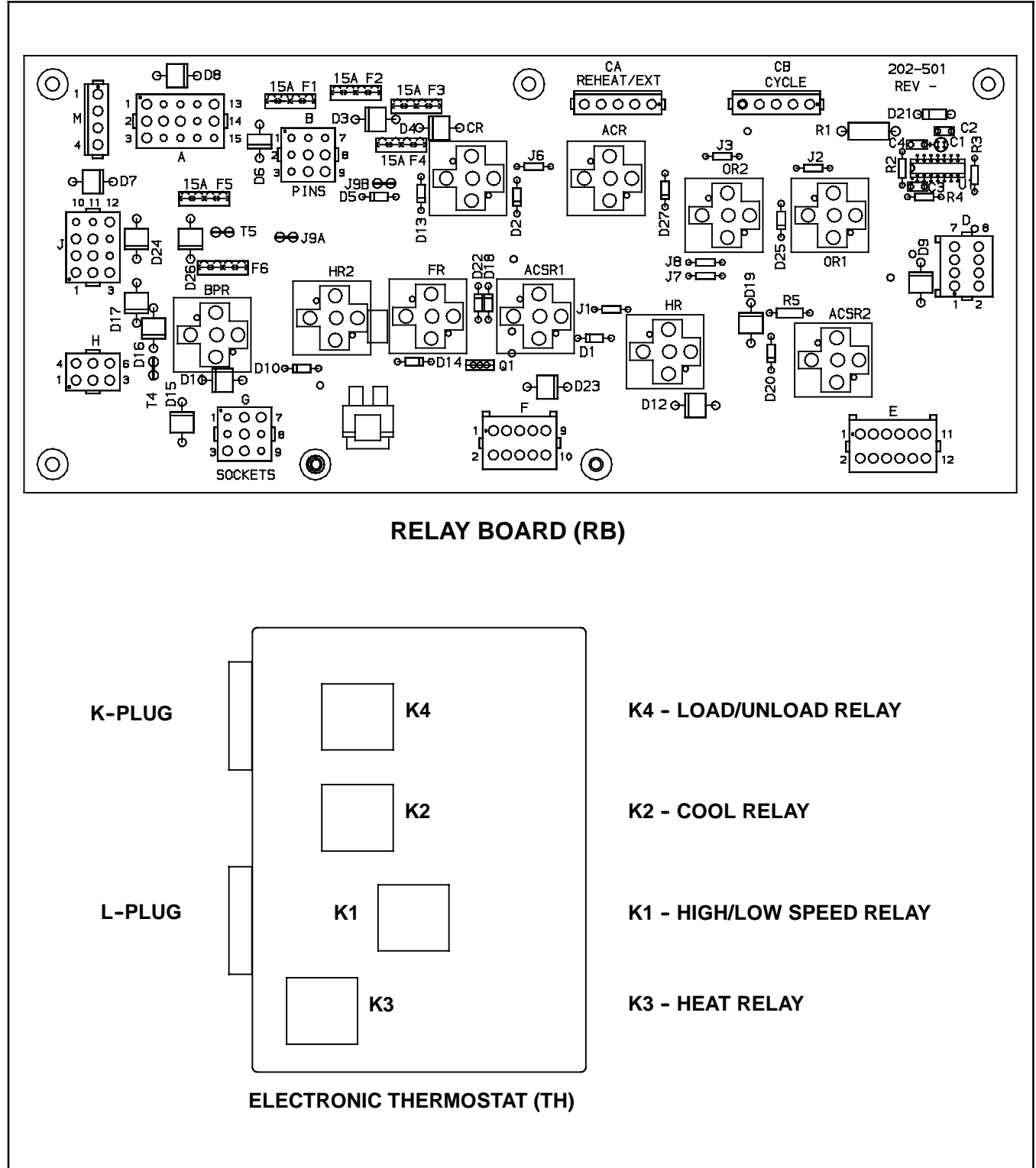

## 5-1 INTRODUCTION

This section contains electrical wiring schematics covering the models listed in Table 1-1. The schematics shown in this section provides information for all system models and optional configurations. The EM-17 evaporators are fitted with 2 blower/motor assemblies. The CM-5 Skirt-Mounted Condenser has 5 fan/motor assemblies and the KR-4 Rooftop Condenser has 4 fan/motor assemblies.

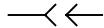

**Figure 5-1 Electrical Control Panel Relay Board (RB) & Electronic Thermostat (TH) Outline Views.**

<u>SYMBOL</u>	<u>DESCRIPTION</u>
ACMS	A/C MODE SWITCH
ACR	A/C RELAY
ACSL	A/C STOP LIGHT
ACSR1	A/C STOP RELAY #1 (TIME DELAYED)
ACSR2	A/C STOP RELAY #2 (TIME DELAYED)
ALT	ALTERNATOR
CFR1 - CFR3	CONDENSER FAN RELAY
CFS1 - CFS2	CONDENSER FAN SPEED SWITCH
CL	CLUTCH
CF1 - CF5	CONDENSER FAN MOTORS
CR	CLUTCH RELAY
CSR	CONDENSER SPEED RELAY
D1 - D30	DIODES
EM1	EVAPORATOR FAN MOTOR #1
EM#2	EVAPORATOR FAN MOTOR #2
ESR - ESR2	EVAPORATOR SPEED RELAY
FR	FAULT RELAY
F2, F4 - F11	FUSE - 15 AMP
F12 & F13	FUSE - 40 AMP
F14	FUSE - 60 AMP
HPS	HIGH PRESSURE SWITCH
LATH	LOW AMBIENT THERMOSTAT
LPS	LOW PRESSURE SWITCH
LLS	LIQUID LINE SOLENOID
PWRR	POWER RELAY
RES	RESISTOR
TB1, TB2 ...	TERMINAL STRIP POSITIONS
TS	THERMOSTAT
UPS1	UNLOADER PRESSURE SWITCH #1
UPS2	UNLOADER PRESSURE SWITCH #2
UPS3	UNLOADER PRESSURE SWITCH #3
UV1	UNLOADER VALVE #1
UV2	UNLOADER VALVE #2

	INDICATES RELAY BOARD TRACE
	INDICATES PLUG LOCATION ON RELAY BOARD
	INDICATES A WIRE GROUND
	INDICATES A CONNECTOR (WEATHER PACK)
	INDICATES A NORMALLY OPEN CONTACT
	INDICATES A NORMALLY CLOSED CONTACT
	INDICATES TERMINAL STRIP

**Figure 5-2 Schematic**  
(Sheet 1 of 3)

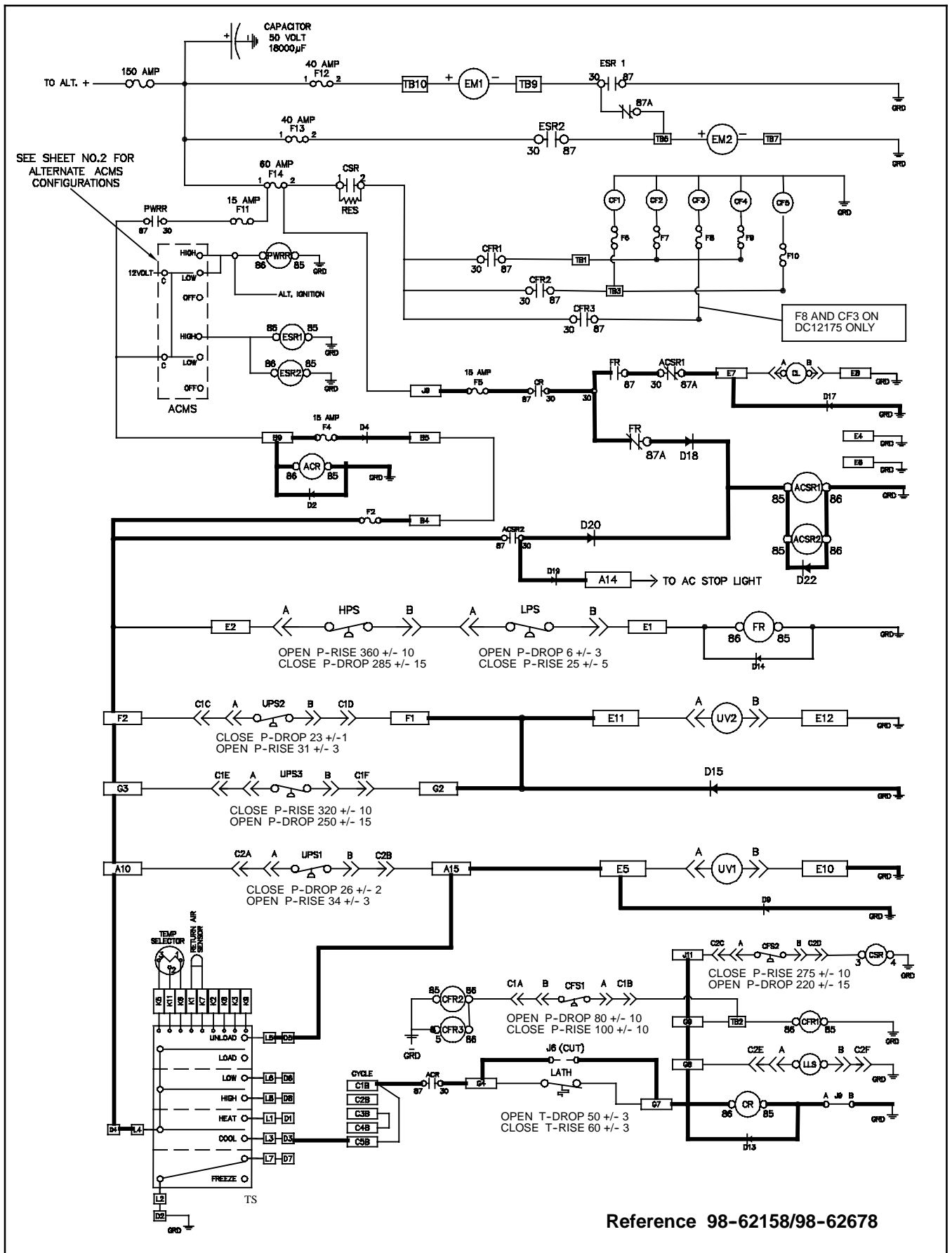
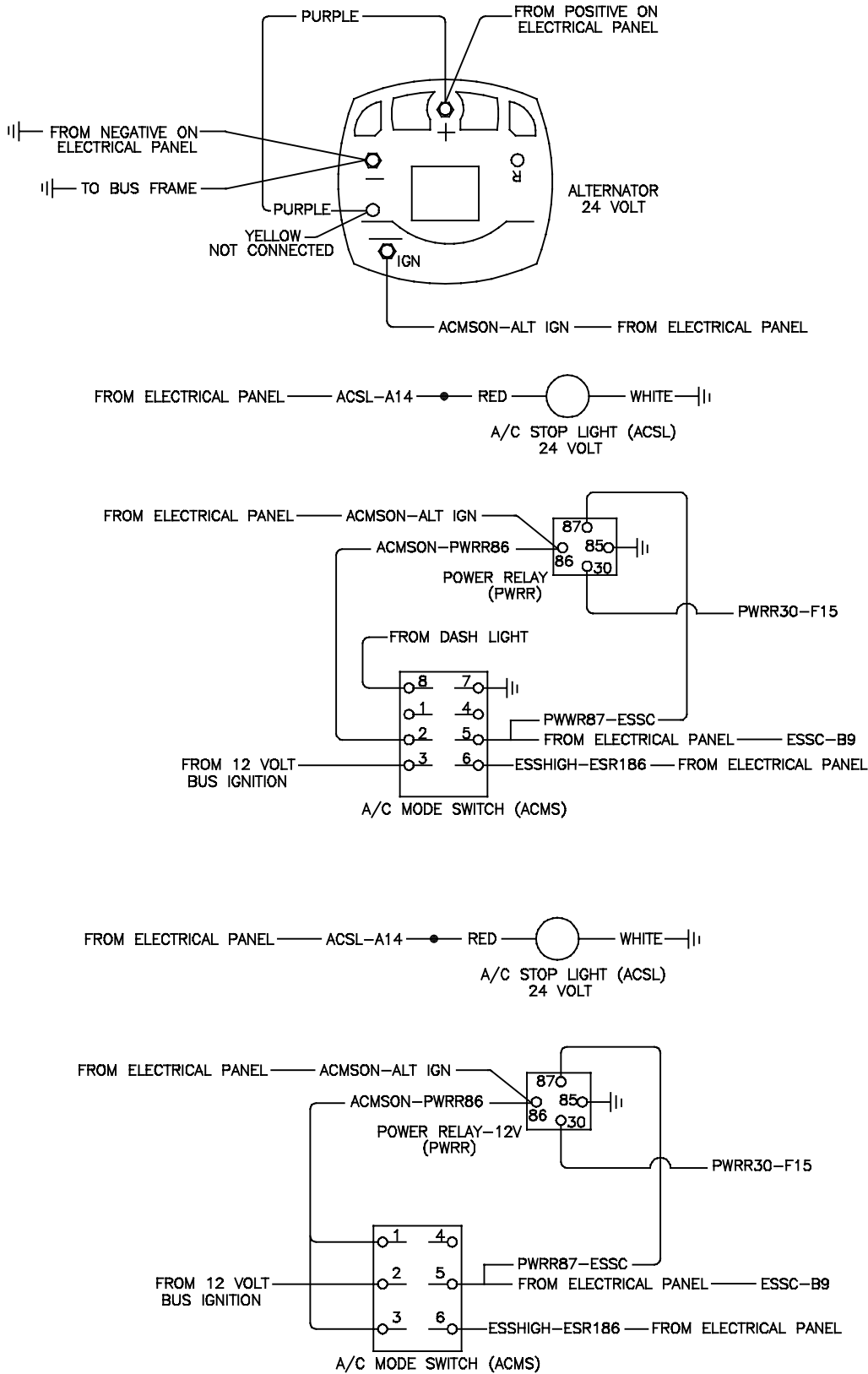

Figure 5-2 Schematic  
(Sheet 2 of 3)



Reference 98-62158/98-62678

Figure 5-2 Schematic  
(Sheet 3 of 3)

# INDEX

## A

Air Filter, 4-10  
Ambient Lockout, 1-6

## C

Clutch, 2-2, 4-12  
Compressor, 4-11  
Condenser Fan, 2-2  
Cooling Mode, 2-1

## D

DESCRIPTION, 1-1  
Discharge Pressure, 2-2

## E

ELECTRICAL, 5-1  
Evacuation, 4-5  
Evacuation, One Time, 4-6  
Evacuation, Triple, 4-5

## F

Filter-Drier, 4-8

## H

High Pressure Switch, 1-6, 4-7

## I

INTRODUCTION , 1-1

## L

LEAK CHECK, 4-5  
Liquid Line Solenoid, 2-2, 4-9

Low Pressure Switch, 1-6, 4-7

## M

Maintenance Schedule, 4-1  
Modes Of Operation, 2-1

## N

Noncondensibles, Check For, 4-7

## O

Oil Level, 4-12  
Operating Instructions, 2-1  
OPERATION, 2-1

## P

Pre-Trip Inspection, 2-1  
Pump Down, 4-3, 4-4

## R

Refrigerant Charge, 4-3, 4-7  
Refrigerant Removal, 4-4, 4-5  
Refrigeration Cycle, 1-6  
Relay Board, 1-3

## S

SAFETY DEVICES, 1-6  
SEQUENCE OF OPERATION, 2-2  
SERVICE, 4-1  
Service Valves, 4-1  
Starting, 2-1  
Stopping, 2-1  
Suction Pressure, 2-2  
Superheat, 4-10



# INDEX

## T

Temperature Control, 2-1, 2-2

Temperature Pressure Chart, 4-15

Temperature Sensor, 1-5, 4-13, 4-14

Thermostatic Expansion Valve, 4-9

TROUBLESHOOTING, 3-1

## U

Unloaders, 2-1

## V

Vent Mode, 2-1

## W

Wiring Schematics, 5-1

Carrier Transport Air Conditioning  
50 Grumbacher Road  
York PA 17406 USA  
Tel: 1-800-673-2431  
Fax: 1-717-764-2219



**Carrier**

A United Technologies Company

Carrier Transicold Division,  
Carrier Corporation  
Transport Air Conditioning Group  
P.O. Box 4805  
Syracuse, N.Y. 13221 U.S.A

[www.carrier.transicold.com](http://www.carrier.transicold.com)



A member of the United Technologies Corporation family. Stock symbol UTX  
©2009 Carrier Corporation D Posted in U. S. A. 0509