

Bill of Materials Listing

TransArctic Canada Inc.

5/21/2015
Page 1 of 1

Product Number	Description	Date	Weight	Uof M	Yield
Line Component Prod#	Description	Bin Unit	Qty		
KMC62502	Mt Kit, ISB, 6.7L, TH C2, F400, '07- '13		08/12/08	59.25	0
5	BEL30787		Belt, Banded B gr,787mm (31") (RBX28-2)	each	1
10	BEL82370		Belt, 8gr, 2370mm (93.3") (5080933)	each	1
30	BMC60030		Bkt, Comp, Main, Weldmt, C2, F400, '07	each	1
40	BMC60034		Bkt, Main, Weldmt, TH C2, F400, '07	each	1
50	BMC67026		Bkt, Support, RAD, F400, TH Cum C2, BLK	each	1
60	BMM60040		Bkt, Main, Weldmt, Bitzer, C2,MBE926,'07	each	1
65	HOA03045		Hose, Flex, CAC, Elb, Silicon, 3.0 x 45d	each	1
70	PUA62502		Pulley, Assy,Idler,P8/2B gr, STL, PLT	each	1
75	PUL67088		Pulley, Fan, OEM, Repl, ISB,6.7, 8gr, 6"	each	1
80	PUL80076		Pulley, Idler, Backside, P8, 76d (89101)	each	1
90	TUS03035		Tube, Stl, 3"/ 3.5" O.D, C2, F400	each	1
110	WFS12001		Washer, Flat, Step, 12mm, 69.85, Plt	each	1
120	KBC62502		Bag Kit, Fasteners, KMC62502	each	1

Bill of Materials Listing

TransArctic Canada Inc.

5/21/2015
Page 1 of 1

Product Number	Description	Date	Weight	Uof M	Yield
Line Component Prod#	Description	Bin Unit	Qty		
KBC62502	Bag Kit, Fasteners, KMC62502		09/02/08	1.77 each.	0
10	BTC08030		Bolt, Hex, 8 x 1.25 x 30mm, 10.9, Plt,FT	each	4
20	BTC10035		Bolt, Hex, 10 x 1.5 x 35mm, 10.9, Plt,FT	each	4
30	BTC10100		Bolt, Hex, 10 x 1.5 x 100mm, 10.9,Plt,FT	each	1
60	BTC12030		Bolt, Hex, 12 x 1.75 x 30mm, 10.9, Plt	each	1
70	BTQ10200		Bolt, Hex, 5/8-11unc, 2", 8. PLT	each	3
80	BTS10001		Bolt, Shoulder, 10mm (89064)	each	1
85	CSF10026		Capscrew, FH, 10 x 1.5 x 25mm, 10.9,Plt	each	1
90	NTL10000		Nut, Lock, Hex, 5/8-11unc, 9, Plt	each	3
110	WFA10000		Washer, Flat, 10mm, 8.8, Plt	each	4
120	WFQ10000		Washer, Flat, 5/8", 8, Plt	each	6
125	WLA08000		Washer, Lock, 8mm, 8.8, Plt	each	4
130	WLA10000		Washer, Lock, 10mm, 8.8, Plt	each	5
140	WLA12000		Washer, Lock, 12mm, 8.8, Plt	each	1

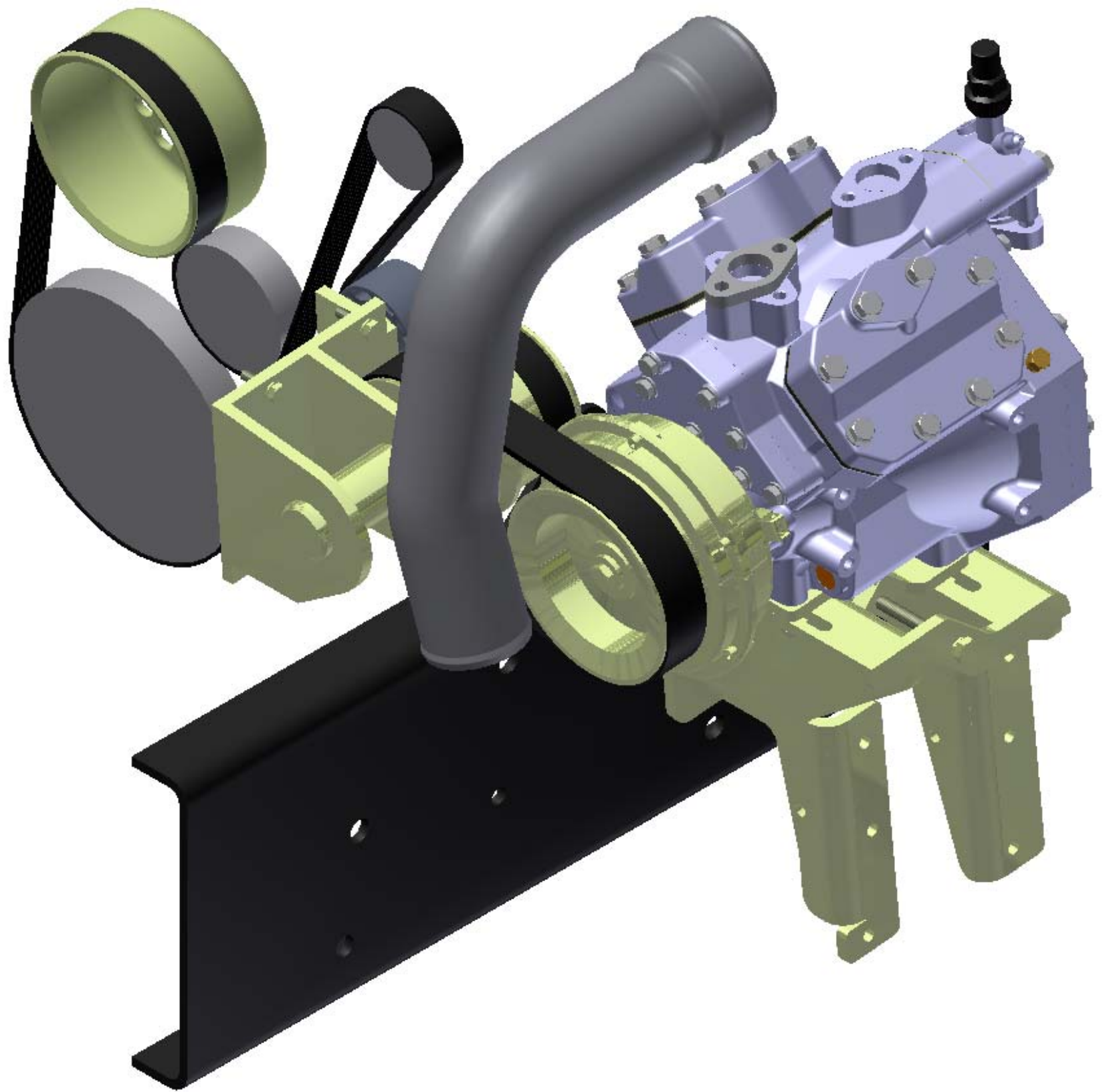

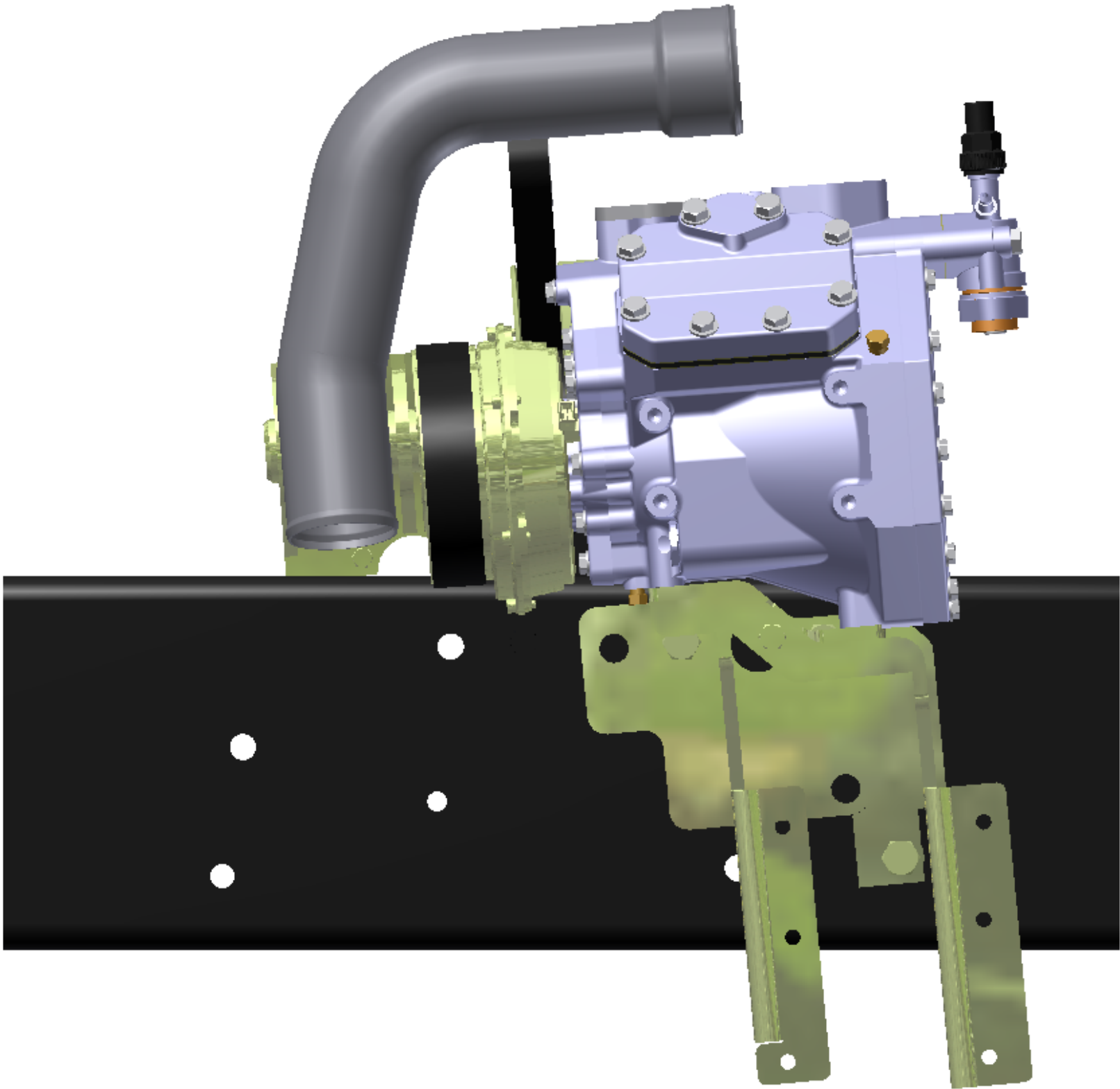

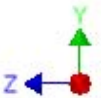
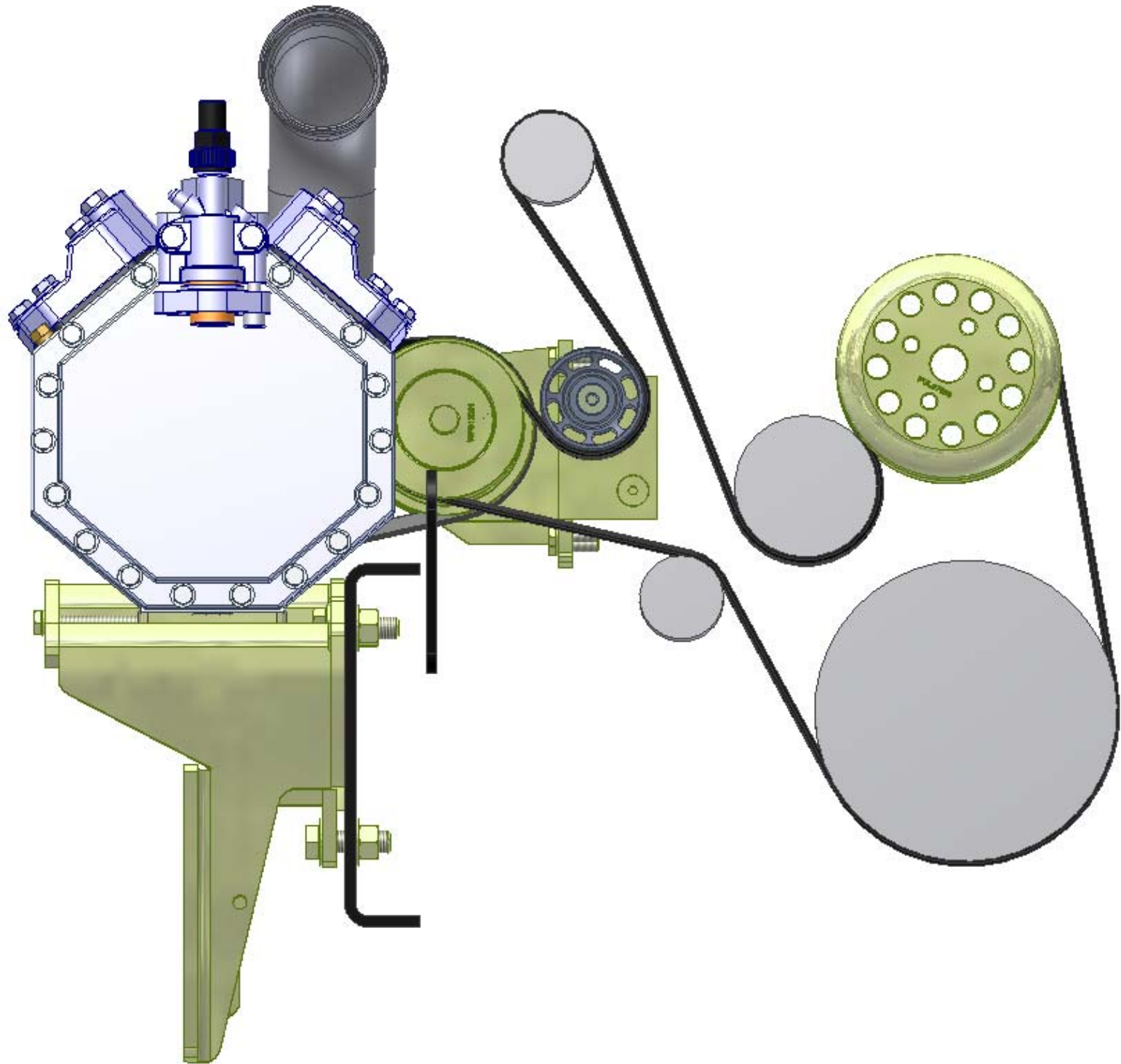

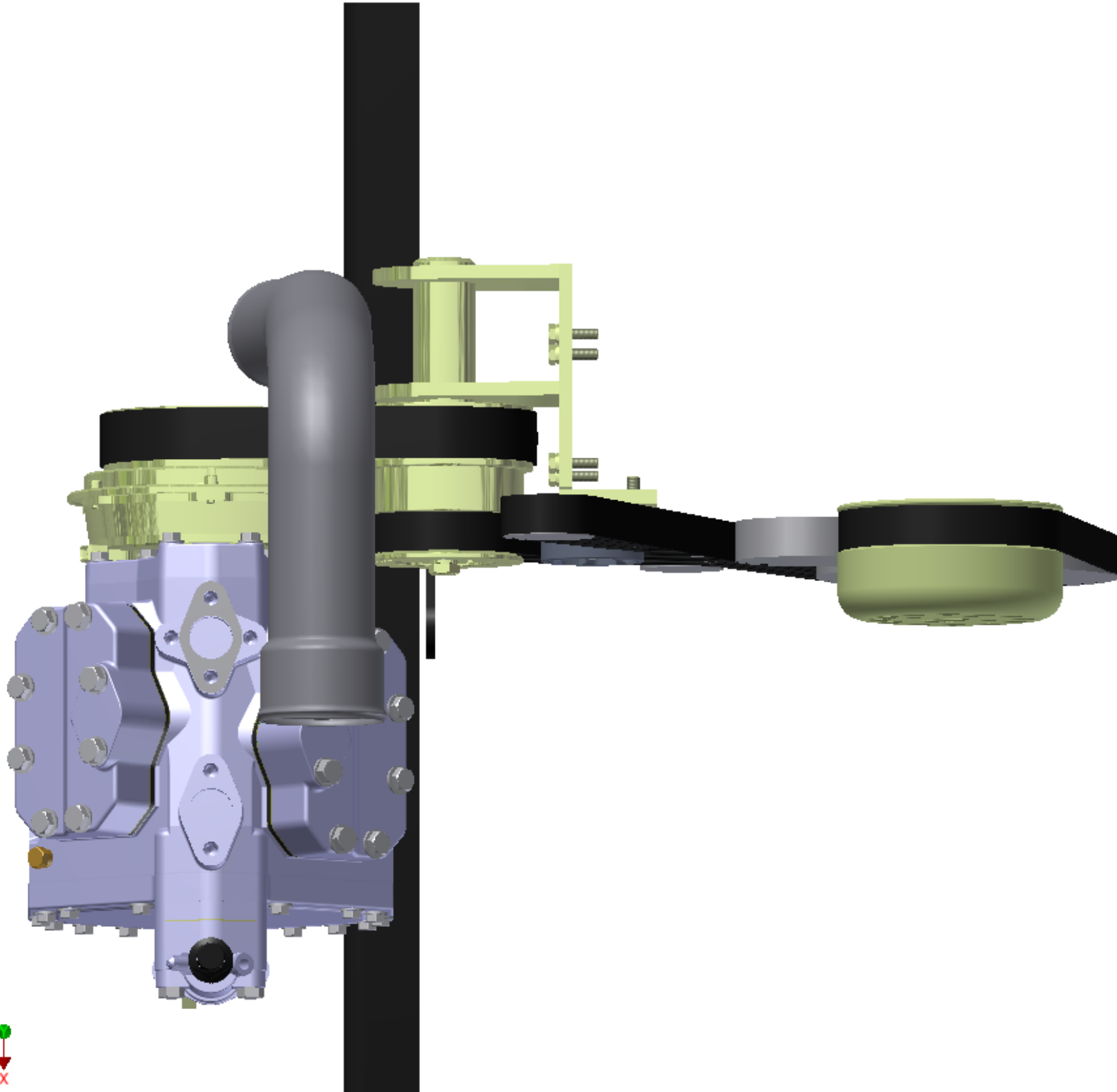

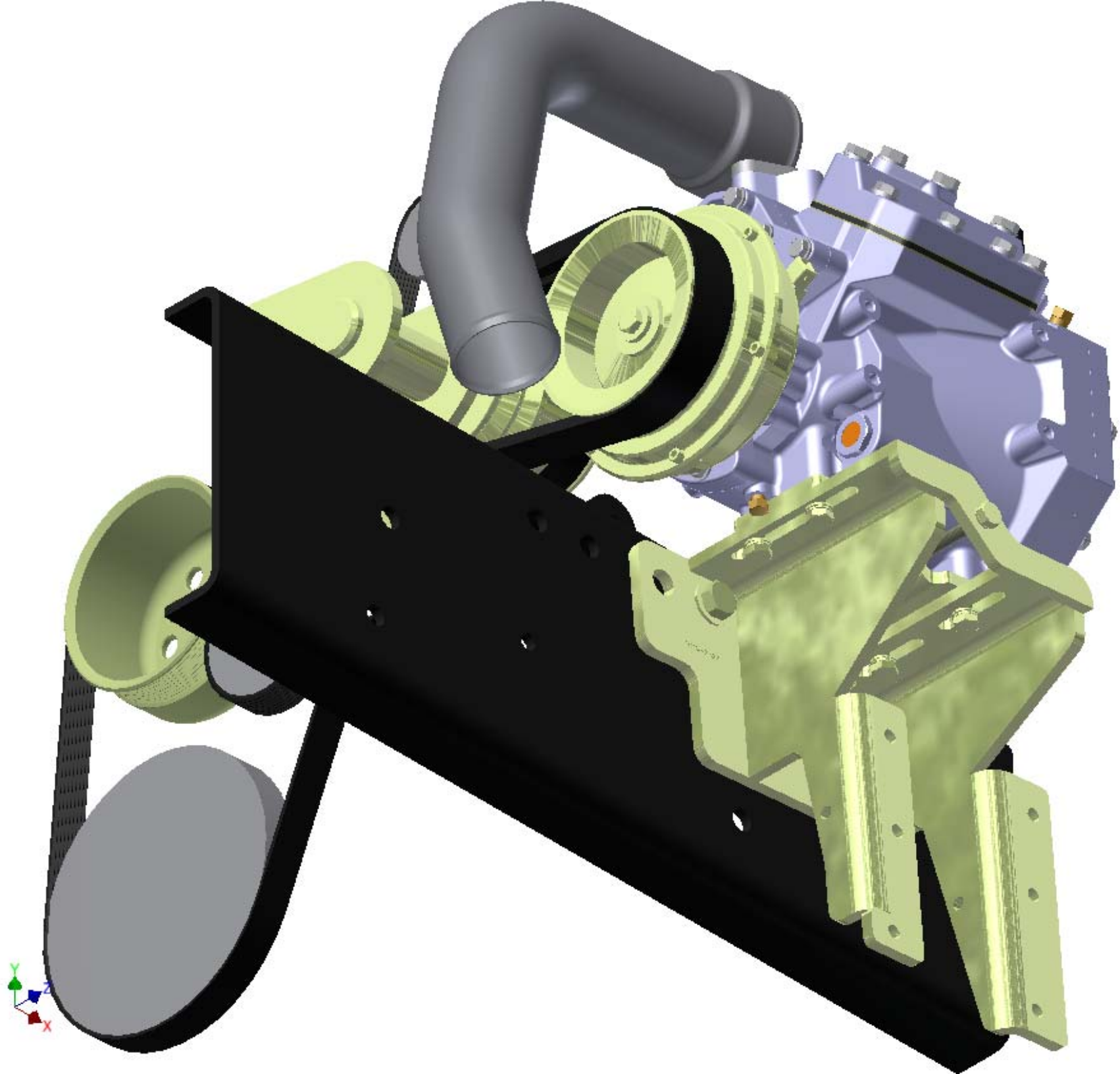

TransArctic A/C Compressor Mount Installation Disclaimer

All compressor mounts should be installed by qualified and trained personnel using proper tools and equipment in safe working conditions following industry standard guidelines for motor vehicle service and repair.

The installer of any compressor mount purchased from TransArctic must undertake all responsibility of issues arising from that compressor bracket being installed on any vehicle. As well as insure that a **proper and sufficient ground** is established between the compressors' clutches and the vehicle's engine. Mount functionality, operation and durability can all be compromised by an incompetent installation.

Due to the many different situations, parameters and application criteria, which are beyond the compressor mount manufacturer's control, TransArctic does not warrant design, durability, or operational functionality of any compressor mount improperly installed by another party.

With no implied guarantees it is the mount installer's strict responsibility to determine safety and functionality, of the compressor mount, at the time of installation.

Please contact TransArctic with any issue arising from installation so we may better improve the product. If you have any reservations about the compressor mount integrity contact TransArctic immediately at 1-877-COLD-AIR.

Mark OEM tensioner location

Install Kit

Check for Interferences

Check to ensure that the proper OEM tensioner orientation is maintained

Run engine with A/C system engaged for at least 10 minutes to run in belt

Check OEM tensioner orientation and adjust as required

Responsabilidad limitada de TransArctic en la instalación del soporte del compresor

Todos los soportes de los compresores deben ser instalados por personas calificadas y entrenadas, usando para ello los equipos y herramientas necesarios para esta labor en buenas condiciones y según las normas y guías para el servicio y/o reparación de motores de vehículos.

El instalador de los soportes comprados en TransArctic asume toda la responsabilidad de cualquier problema que surga en el soporte del compresor al vehículo; de igual manera es responsable que el cable a tierra sea conectado entre el embrague del compresor y el motor del vehículo.

Se advierte que el buen funcionamiento y la durabilidad del soporte pueden ser comprometidos por defectos en su instalación.

Debido a las diversas situaciones que se puedan presentar fuera del control del fabricante, TransArctic no garantiza el diseño, la durabilidad o el correcto funcionamiento de cualquier equipo inapropiadamente instalado por terceros.

Esta sobreentendido que el Instalador del montaje del compresor es estrictamente responsable de la seguridad y funcionamiento del equipo en el momento de la instalación.

Si tuviera algún problema o duda acerca de la instalación del soporte del compresor pongase en contacto inmediatamente con TransArctic al teléfono 1-877-COLD-AIR de modo que podamos mejorar nuestro producto.

Note la ubicación del medidor de tensión OEM

Instale el equipo

Controlar si hay interferencias.

Asegurese que el medidor de tensión mantenga la orientación justa.

Encienda el motor por lo menos 10 minutos con el sistema A/C enganchado para que la correa corra

Controle la orientación justa del medidor de tensión y ajuste a las condiciones requeridas del fabricante